

LIQUID CRYSTAL DISPLAY MODULE

Product Specification

PRODUCT NUMBER	LR2230
-----------------------	---------------

INTERNAL APPROVALS		
Product Manager	Engineering	Document Control

TABLE OF CONTENTS

1	MAIN FEATURES	4
2	MECHANICAL DRAWING	5
3	ABSOLUTE MAXIMUM RATINGS	6
4	ELECTRONICAL CHARACTERISTICS	6
4.1	DC CHARACTERISTICS	6
4.2	LCM CURRENT CONSUMPTION & DRIVING VOLTAGE	6
5	OPTICAL CHARACTERISTICS	7
6	BACKLIGHT ELECTRICAL CHARACTERISTICS	8
7	OPERATING INSTRUCTIONS	9
7.1	I/O PIN FUNCTION (ARRAY LED).....	9
7.2	AC CHARACTERISTICS	10
7.3	TIMING CHARACTERISTICS	11
7.1	CHARACTER FONT	12
8	POWER SUPPLY.....	13
9	BLOCK DIAGRAM.....	13
10	RELIABILITY TEST	14
10.1	RELIABILITY (NORMAL TEMP. LCD).....	14
10.2	RELIABILITY (WIDE TEMP. LCD).....	14
10.3	MTBF OF LIQUID CRYSTAL PANEL	14
11	PART NUMBER DESCRIPTION	15
12	QUALITY ASSURANCE SPECIFICATION	16
12.1	CONFORMITY.....	16
12.2	DELIVERY ASSURANCE	16
13	HANDLING PRECAUTIONS	20

REVISION RECORD

Rev.	Date	Page	Par.	Comment	ECN no.
A	07/15/08	--	--	New DCA Specification	E3787

1 MAIN FEATURES

ITEM	CONTENTS	UNIT
Outline Dimension	122.0 (W) x 44.0 (H) x 11.3 Max (D)	mm
Display Format	16 Characters x 2 Lines	Dots
Backlight Type and Color	EL / Blue-Green	--
Active Area	94.84 (W) x 20.0 (H)	mm
Viewing Area	99.0 (W) x 24.0 (H)	mm
Character Dimensions	4.84 x 8.06	mm
Character Pitch	6.0 x 10.34	mm
Duty Ratio	1/16	Duty
Bias Drive	1/5	Bias
IC Controller	Sitronix ST7066	--
Power Supply	Vdd (+5)	Volts
RoHS Complaint	Yes	--

2 MECHANICAL DRAWING

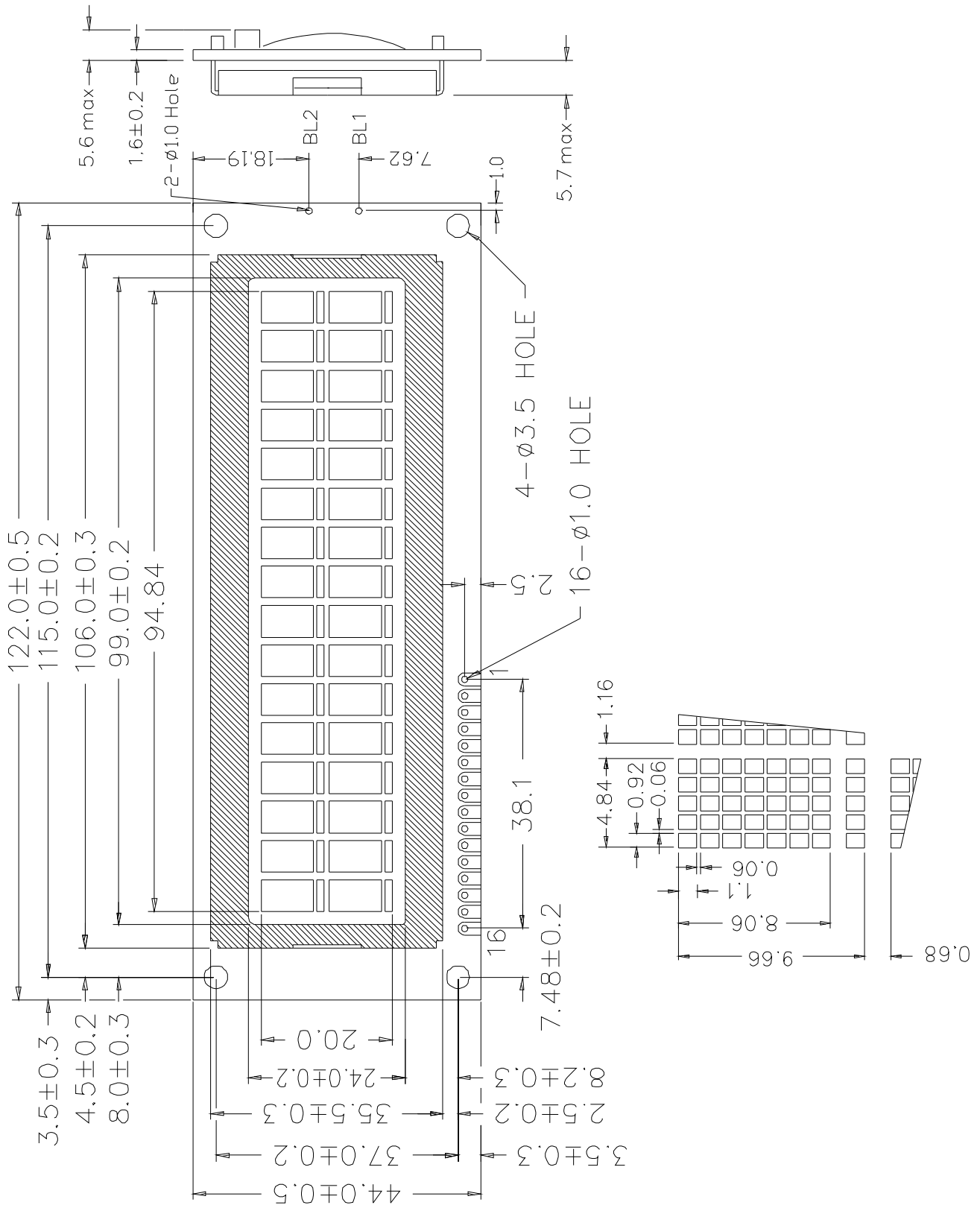

Product No.	LR2230	REV. A
-------------	--------	--------

Page	5 / 20
------	--------

3 ABSOLUTE MAXIMUM RATINGS

Item	Symbol	Conditions	Min	Max	Unit
Power Supply Voltage	V _{DD}	Ta=25°C ,50±10%RH	0	7.0	V
Operating Temperature	Topr	<65% (Normal Temp.)	0	50	°C
		<65% (Wide Temp.)	-20	70	°C
Storage Temperature	Tstg	<65% (Normal Temp.)	-20	70	°C
		<65% (Wide Temp.)	-30	80	°C
		<48 hrs	20	90	%RH
		<1000 hrs	20	65	%RH

4 ELECTRICAL CHARACTERISTICS

4.1 DC CHARACTERISTICS

(V_{SS}=0V, Ta =25°C)

Item	Symbol	Condition	Min	Typ	Max	Unit
Operating Voltage	V _{DD}	--	4.75	--	5.25	V
Input Voltage	Vi _{hc}	High level	0.7V _{DD}	--	V _{DD}	V
	Vi _{lc}	Low level	0	--	0.55	
LCD Driving Voltage	V _{DD} - V _O	--	3.0	V	10.0	V

4.2 LCM CURRENT CONSUMPTION & DRIVING VOLTAGE

(V_{DD} - V_{SS} = 5.0V)

		STN TEMPERATURE	
		Normal	Wide
Supply Current , (I _{DD}) Typ. ,mA		2.4	2.4
Recommended LCD Driving Voltage			
LCD Driving Voltage (V _{DD} - V _O)	Ta = -20 °C	N/A	7.4
	Ta = 0 °C	4.8	7.1
	Ta = 25 °C	4.4	6.7
	Ta = 50 °C	4.0	6.5
	Ta = 70 °C	N/A	6.2

5 OPTICAL CHARACTERISTICS

STN TYPE LCD

(Ta=25°C)

Item	Symbol	Condition	Mn.	Typ.	Max.	Unit	Note
Viewing Angle	1 (down)	CR \geq 2	--	40	--	deg.	5.1
	2 (up)	CR \geq 2	--	25	--	deg.	5.1
	3 (right)	CR \geq 2	--	20	--	deg.	5.2
	4 (left)	CR \geq 2	--	20	--	deg.	5.2
Contrast Ratio	CR	Ta=25°C	2.0	3.0	--	--	5.3
Response Time	Tr	Ta=25°C	--	120	180	ms	5.4
	Tf	Ta=25°C	--	220	330		
Driving Method	Duty	1/16					
	Bias	1/5					

Note 5.1: Definition of viewing angle θ_1 & θ_2

Note 5.2: Definition of viewing angle θ_3 & θ_4

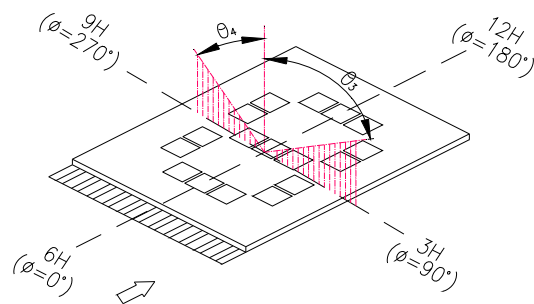
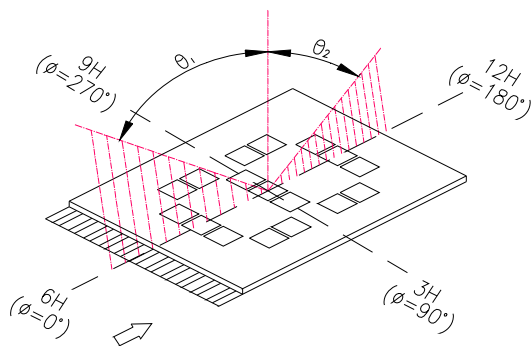

Note 5.3: Definition of contrast ratio (CR)

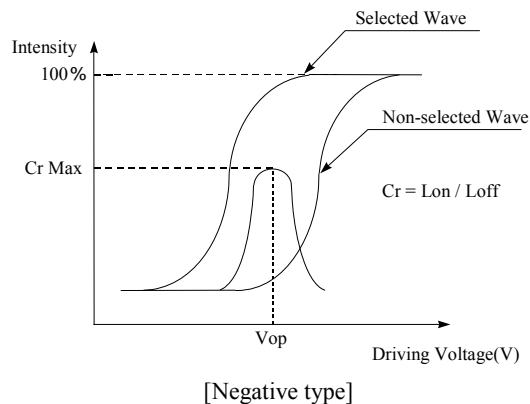
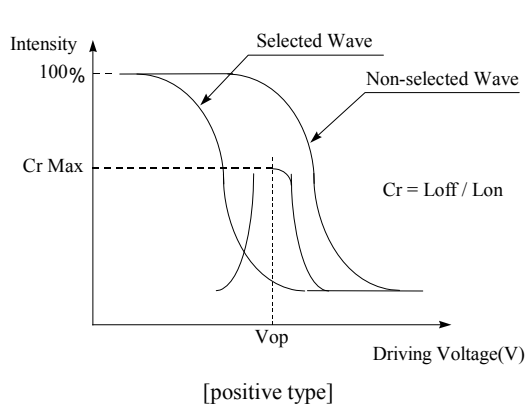

Note 5.4: Definition of response time

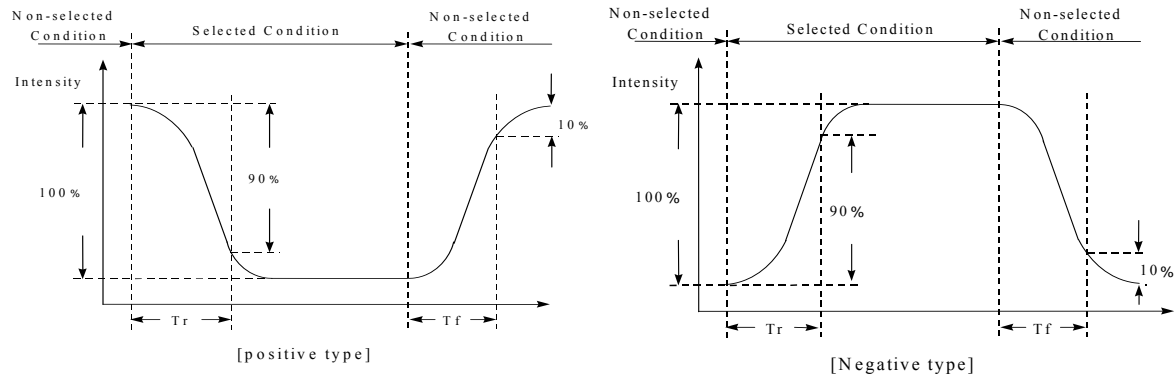

6 BACKLIGHT ELECTRICAL CHARACTERISTICS

EL BACKLIGHT OPERATING RANGE

Item	Conditions	Min.	Typ.	Max.	Unit
Input voltage	Ta=25°C (400~800 Hz)	--	100	--	Vrms
Current consumption	Ta=25°C	--	4.0	--	mA
Average brightness (B/L only)(Ta=25°C, I=4.0mA)	Test when connecting after 3 min. Ta = 25 °C (max. contrast)				cd/m ² (Note 6.1)
	--	--	50	--	
Lamp life	Ta=25°C, I=4.0mA Humidity:30%RH~85%RH	--	3,000	--	Hrs (Note 6.2)
Operating Temp.	Humidity:30%RH~85%RH	-20	--	70	°C
Storage Temp.	Humidity:30%RH~85%RH	-30	--	80	°C

Note 6.1: R2: Suggest BL current limit resistor on customer board.

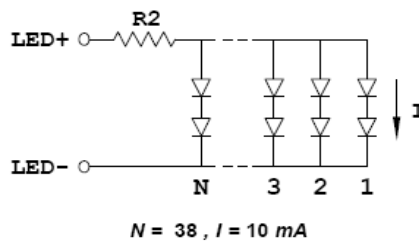

Note 6.2: Brightness uniformity = (MIN / MAX) x 100 %.

7 OPERATING INSTRUCTIONS

7.1 I/O PIN FUNCTION (EL)

Pin No.	Function	Level	Description
1	Vss	--	Ground (0V) and cathode of LED B/L
2	Vdd	--	Logic Supply Voltage (+5V)
3	Vo	--	Voltage Level for LCD Control Adjustment
4	RS	I	Register Select 0: Instruction Register 1: Data Register
5	R/W	I	Read / Write 0: Data Write (Module-MPU) 1: Data Read (Module-MPU)
6	E	I	Enable Signal Active High (H - L)
7 ~ 14	DB0 ~ DB7	I/O	Bi-directional data bus line 0 ~ 7
15	NC	--	No connection
16	N/A	--	--
BL1	EL	--	EL Backlight
BL2	EL	--	EL Backlight

7.2 AC CHARACTERISTICS

(Ta = 25°C, Vcc = 5V)

Symbol	Characteristics	Test Condition	Min.	Typ.	Max.	Unit
Internal Clock Operation						
f _{OSC}	OSC Frequency	R = 91K Ω	190	270	350	KHz
External Clock Operation						
f _{EX}	External Frequency	--	125	270	410	KHz
--	Duty Cycle	--	45	50	55	%
T _R , T _F	Rise/Fall Time	--	--	--	0.2	μs
Write Mode (Writing data from MPU to ST7066U)						
T _C	Enable Cycle Time	Pin E	1200	--	--	ns
T _{PW}	Enable Pulse Width	Pin E	140	--	--	ns
T _R , T _F	Enable Rise/Fall Time	Pin E	--	--	25	ns
T _{AS}	Address Setup Time	Pins: RS, RW, E	0	--	--	ns
T _{AH}	Address Hold Time	Pins: RS, RW, E	10	--	--	ns
T _{DSW}	Data Setup Time	Pins: DB0 - DB7	40	--	--	ns
T _H	Data Hold Time	Pins: DB0 - DB7	10	--	--	ns
Read Mode (Reading data from ST7066U to MPU)						
T _C	Enable Cycle Time	Pin E	1200	--	--	ns
T _{PW}	Enable Pulse Width	Pin E	140	--	--	ns
T _R , T _F	Enable Rise/Fall Time	Pin E	--	--	25	ns
T _{AS}	Address Setup Time	Pins: RS, RW, E	0	--	--	ns
T _{AH}	Address Hold Time	Pins: RS, RW, E	10	--	--	ns
T _{DDR}	Data Setup Time	Pins: DB0 - DB7	--	--	100	ns
T _H	Data Hold Time	Pins: DB0 - DB7	10	--	--	ns
Interface Mode with LCD Driver (ST7065)						
T _{CWH}	Clock Pulse with High	Pins: CL1, CL2	800	--	--	ns
T _{CWL}	Clock Pulse with Low	Pins: CL1, CL2	800	--	--	ns
T _{CST}	Clock Setup Time	Pins: CL1, CL2	500	--	--	ns
T _{SU}	Data Setup Time	Pin: D	300	--	--	ns
T _{DH}	Data Hold time	Pin: D	300	--	--	ns
T _{DM}	M Delay Time	Pin: M	0	--	2000	ns

7.3 TIMING CHARACTERISTICS

- Writing data from MPU to ST7066U

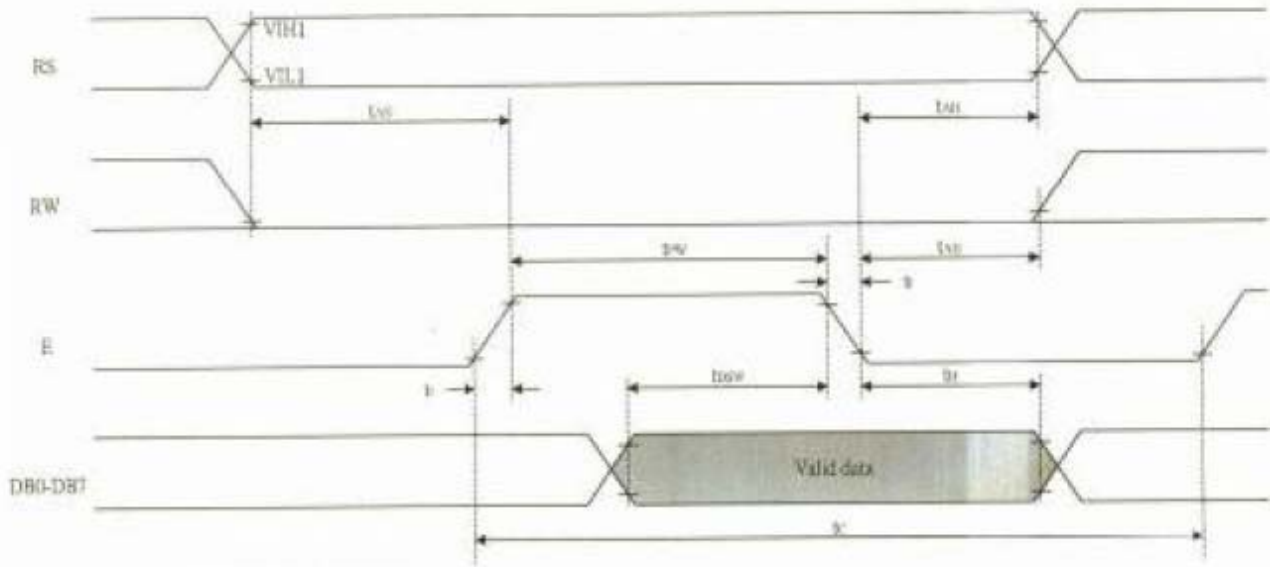

- Reading data from ST7066U to MPU

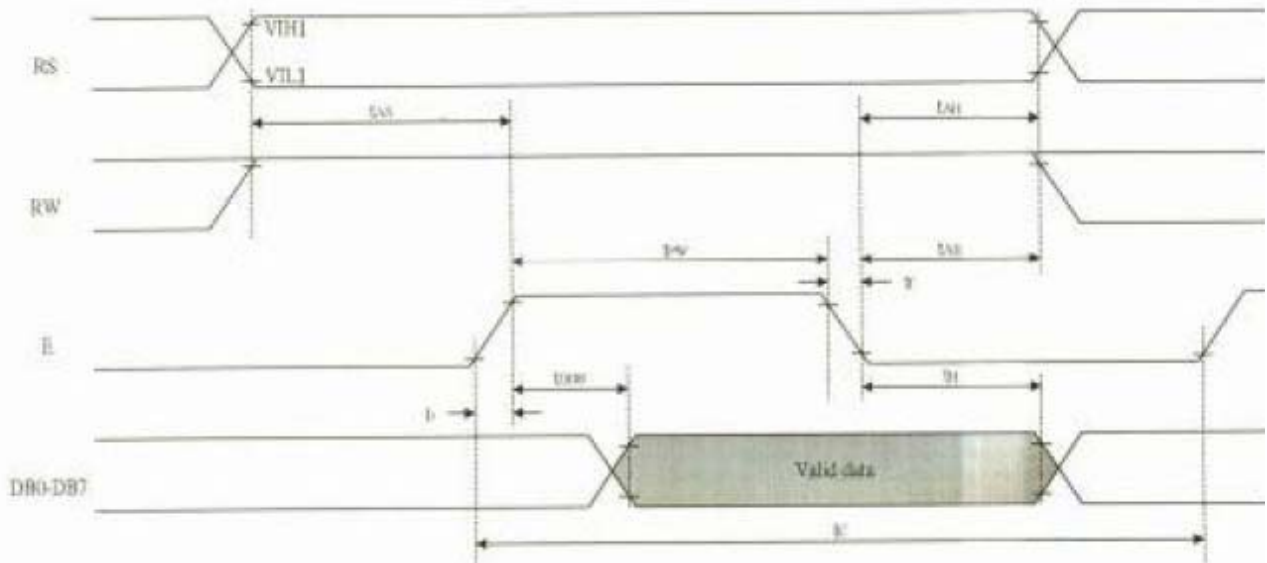

7.1 CHARACTER FONT

b7-b4 b3-b0	0000	0001	0010	0011	0100	0101	0110	0111	1000	1001	1010	1011	1100	1101	1110	1111	
0000	CG RAM (1)			0	@	P	`	P				-	9	E	e	p	
0001	(2)		!	1	A	Q	a	q			.	7	+	4	a	g	
0010	(3)		"	2	B	R	b	r			^	Y	W	X	P	e	
0011	(4)		#	3	C	S	c	s			^	U	T	E	E	e	
0100	(5)		\$	4	D	T	d	t			\	I	T	P	N	a	
0101	(6)		%	5	E	U	e	u			.	O	A	I	E	U	
0110	(7)		&	6	F	V	f	v			9	O	N	O	P	Z	
0111	(8)		'	7	G	W	g	w			7	+	X	U	g	π	
1000	(1)		(8	H	X	h	x			Y	U	N	V	J	X	
1001	(2))	9	I	Y	i	y			9	T	J	U	"	Y	
1010	(3)		*	:	J	Z	j	z			E	C	O	N	V	J	*
1011	(4)		+	:	K	E	k	e			*	S	E	O	*	π	
1100	(5)		,	<	L	¶	l	¶			h	S	F	F	φ	π	
1101	(6)		-	=	M	J	m	j			Y	S	\	U	U	÷	
1110	(7)		.	>	N	^	n	+			9	E	h	°	π		
1111	(8)		/	?	O	_	o	+			W	Y	M	°	ö	■	

8 POWER SUPPLY

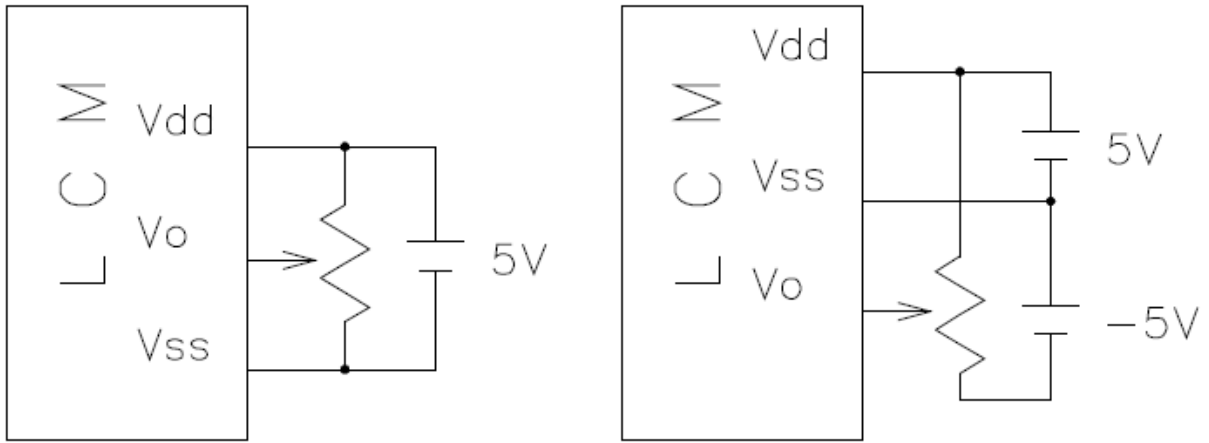

Normal temp.

Wide temp.

RECOMMENDED V_R : 10k ohm ~ 20K ohm

9 BLOCK DIAGRAM

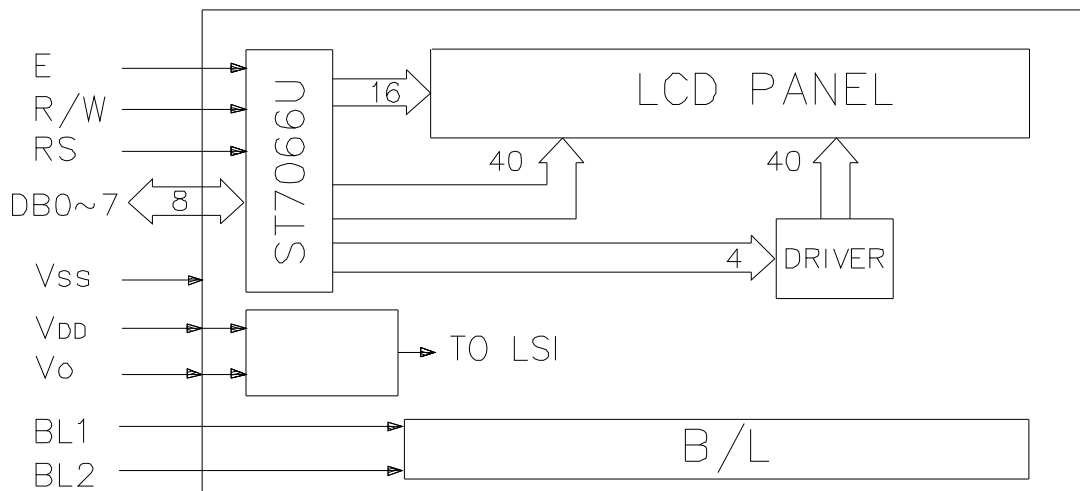

10 RELIABILITY TEST

10.1 RELIABILITY (NORMAL TEMP. LCD)

Test Item	Test Condition	Note
High Temperature Operation	240 HR , 50°C ± 2°C	No abnormalities in function* and appearance**
Low Temperature Operation	240 HR , 0°C ± 2°C	No abnormalities in function* and appearance**
Thermal Shock Storage (None operation)	-20 °C (30 min.) → 25 °C (5 min.) → 70 °C (30 min.) → 25 °C (5 min.) 5 cycle	No abnormalities in function* and appearance**
Vibration (None operation)	10 Hz ~ 55 Hz 0.3 mm / 1 Octave 55 Hz ~ 500 Hz 3g / 1 Octave 20 cycle / per axis	No abnormalities in function* and appearance**

10.2 RELIABILITY (WIDE TEMP. LCD)

Test Item	Test Condition	Note
High Temperature Operation	240 HR , 70°C ± 2°C	No abnormalities in function* and appearance**
Low Temperature Operation	240 HR , -20°C ± 2°C	No abnormalities in function* and appearance**
Thermal Shock Storage (None operation)	-30 °C (30 min.) → 25 °C (5 min.) → 80 °C (30 min.) → 25 °C (5 min.) 5 cycle	No abnormalities in function* and appearance**
Vibration (None operation)	10 Hz ~ 55 Hz 0.3 mm / 1 Octave 55 Hz ~ 500 Hz 3g / 1 Octave 20 cycle / per axis	No abnormalities in function* and appearance**

10.3 MTBF OF LIQUID CRYSTAL PANEL

50,000 hours, 90% Confidence Level at 25°C, 65% RH Max.

If any of the following occurs after the MTBF test, the LCD is deemed to be failed:

- Current consumption increase three times than initial value.
- Damaged glass plug and/or polarizer on the LCD glass.
- Non-operational display.

11 PART NUMBER DESCRIPTION

LR2230①②**2C16**③④⑤

①

Polarizer Type

A = Reflective
B = Transflective
E = Transmissive: Negative Mode
F = Transmissive: Positive Mode

②

Backlight Color

B = Blue-green

③

Fluid Type and Temperature Range

S = Standard temperature range
H = Wide temperature range; negative supply voltage required

④

Fluid Type and Temperature Compensation

S = STN

⑤

Background Color

Y = Yellow Mode STN
G = Gray Mode STN
B = Blue Mode STN

12 QUALITY ASSURANCE SPECIFICATION

12.1 CONFORMITY

The performance, function and reliability of the shipped products conform to the Product Specification.

12.2 DELIVERY ASSURANCE

12.2.1 Delivery inspection standards

- IPC-AA610, class 2 electronic assemblies standard

The quality assurance levels are shown below:

Rank	Item Inspected	Defect type	AQL	Remark
Major defect	Display	Non display	0.25%	Fit/Function defect
		Over current		
		Missing segment		
		Wrong viewing direction		
		Incorrect operating		
		Backlight OFF		
	Backlight flashing			
Dimension	PCB and bezel out of specification			
Minor defect	LCD	Black and white spot	1.0%	Appearance defect
		Black and white lines		
		Polariser scratch		
		Bubbles in polariser		
		Segment deformation, pin hole		
		Colour uniformity		
	COB	Glass chip		
		Wire bond pad exposed		
		Insufficient covering with resin (wire bond line exposed)		
	PCB	Bubble, dust on COB		
Dust, solder ball on PCB				
Tray	Pad scratch			
	Tray	Particles	Every tray	
		Total	1.0%	

12.2.2 Zone definition

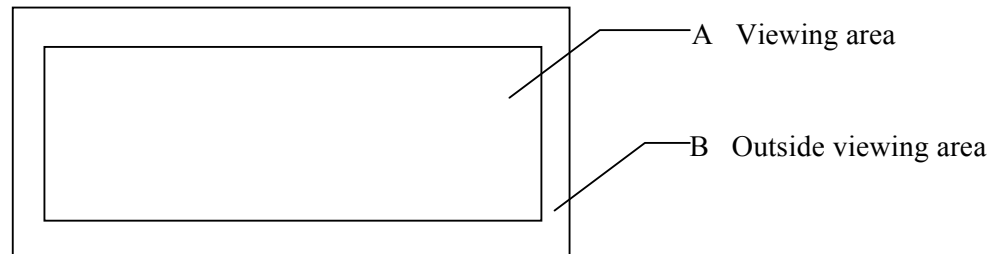

12.2.3 Visual inspection

- Inspect under 2x20W or 40W fluorescent lamp (approximately 3000 lux) leaving 25 to 30 cm between the module and the lamp and 30 cm between the module and the eye (measuring position).
- Appearance is inspected at the best contrast voltage (best contrast is adjusted considering clearness and crosstalk on screen).
- Inspect the module at 45° right and left, top and bottom.
- Use the optimum viewing angle during the contrast inspection.

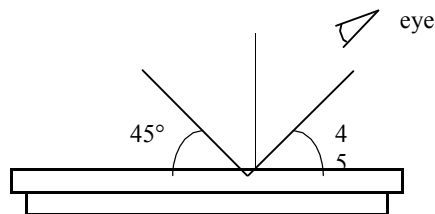

12.2.3.1 Standard of appearance inspection

units: mm

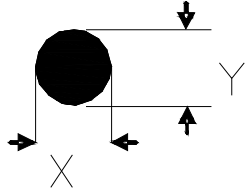
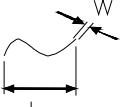
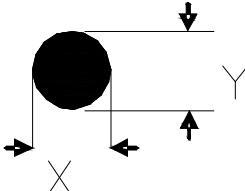
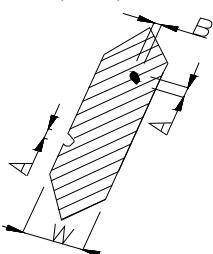
No.	Item	Criteria																																				
1	Black spot, White spot, dust	<p>Round type: as per following drawing</p> $\Phi = (X+Y)/2$  <table border="1" style="margin-left: auto; margin-right: auto;"> <thead> <tr> <th colspan="3">Acceptable quantity</th> </tr> <tr> <th>size</th> <th>Zone A</th> <th>Zone B</th> </tr> </thead> <tbody> <tr> <td>$\Phi < 0.1$</td> <td>Any number</td> <td rowspan="4">Any number</td> </tr> <tr> <td>$0.1 < \Phi < 0.2$</td> <td>2</td> </tr> <tr> <td>$0.2 < \Phi < 0.25$</td> <td>1</td> </tr> <tr> <td>$0.25 < \Phi$</td> <td>0</td> </tr> </tbody> </table> <p>Line type: as per following drawing</p>  <table border="1" style="margin-left: auto; margin-right: auto;"> <thead> <tr> <th colspan="4">Acceptable quantity</th> </tr> <tr> <th>Length</th> <th>Width</th> <th>Zone A</th> <th>Zone B</th> </tr> </thead> <tbody> <tr> <td>-</td> <td>$W \leq 0.02$</td> <td rowspan="2">Any number</td> <td rowspan="3">Any number</td> </tr> <tr> <td>$L \leq 3.0$</td> <td>$0.02 < W \leq 0.03$</td> </tr> <tr> <td>$L \leq 2.5$</td> <td>$0.03 < W \leq 0.05$</td> <td>2</td> </tr> <tr> <td>-</td> <td>$0.05 < W$</td> <td colspan="2">as round type</td> </tr> </tbody> </table> <p style="text-align: center;">Total acceptable quantity: 3</p>	Acceptable quantity			size	Zone A	Zone B	$\Phi < 0.1$	Any number	Any number	$0.1 < \Phi < 0.2$	2	$0.2 < \Phi < 0.25$	1	$0.25 < \Phi$	0	Acceptable quantity				Length	Width	Zone A	Zone B	-	$W \leq 0.02$	Any number	Any number	$L \leq 3.0$	$0.02 < W \leq 0.03$	$L \leq 2.5$	$0.03 < W \leq 0.05$	2	-	$0.05 < W$	as round type	
Acceptable quantity																																						
size	Zone A	Zone B																																				
$\Phi < 0.1$	Any number	Any number																																				
$0.1 < \Phi < 0.2$	2																																					
$0.2 < \Phi < 0.25$	1																																					
$0.25 < \Phi$	0																																					
Acceptable quantity																																						
Length	Width	Zone A	Zone B																																			
-	$W \leq 0.02$	Any number	Any number																																			
$L \leq 3.0$	$0.02 < W \leq 0.03$																																					
$L \leq 2.5$	$0.03 < W \leq 0.05$	2																																				
-	$0.05 < W$	as round type																																				
2	Polariser scratch	Scratch on protective film is permitted Scratch on polariser: same as No. 1																																				
3	Polariser bubble	$\Phi = (X+Y)/2$  <table border="1" style="margin-left: auto; margin-right: auto;"> <thead> <tr> <th colspan="3">Acceptable quantity</th> </tr> <tr> <th>Size</th> <th>Zone A</th> <th>Zone B</th> </tr> </thead> <tbody> <tr> <td>$\Phi < 0.2$</td> <td>Any number</td> <td rowspan="4">Any number</td> </tr> <tr> <td>$0.2 < \Phi < 0.5$</td> <td>2</td> </tr> <tr> <td>$0.5 < \Phi < 1.0$</td> <td>1</td> </tr> <tr> <td>$1.0 < \Phi$</td> <td>0</td> </tr> </tbody> </table> <p>Total acceptable quantity: 3</p>	Acceptable quantity			Size	Zone A	Zone B	$\Phi < 0.2$	Any number	Any number	$0.2 < \Phi < 0.5$	2	$0.5 < \Phi < 1.0$	1	$1.0 < \Phi$	0																					
Acceptable quantity																																						
Size	Zone A	Zone B																																				
$\Phi < 0.2$	Any number	Any number																																				
$0.2 < \Phi < 0.5$	2																																					
$0.5 < \Phi < 1.0$	1																																					
$1.0 < \Phi$	0																																					
4	Segment deformation	<p>I.a. Pin hole on segmented display</p> <p>W: segment width</p> $\Phi = (A+B)/2$  <table border="1" style="margin-left: auto; margin-right: auto;"> <thead> <tr> <th colspan="2">Acceptable quantity</th> </tr> <tr> <th>Width</th> <th>Φ</th> </tr> </thead> <tbody> <tr> <td>$W \leq 0.4$</td> <td>$\Phi \leq 0.2$ and $\Phi \leq 1/2W$</td> </tr> <tr> <td>$W > 0.4$</td> <td>$\Phi \leq 0.25$ and $\Phi \leq 1/3W$</td> </tr> </tbody> </table> <p>Total acceptable quantity: 1 defect per segment Pin holes with Φ under 0.10 mm are acceptable.</p>	Acceptable quantity		Width	Φ	$W \leq 0.4$	$\Phi \leq 0.2$ and $\Phi \leq 1/2W$	$W > 0.4$	$\Phi \leq 0.25$ and $\Phi \leq 1/3W$																												
Acceptable quantity																																						
Width	Φ																																					
$W \leq 0.4$	$\Phi \leq 0.2$ and $\Phi \leq 1/2W$																																					
$W > 0.4$	$\Phi \leq 0.25$ and $\Phi \leq 1/3W$																																					

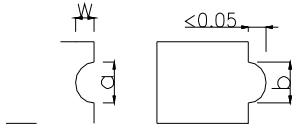
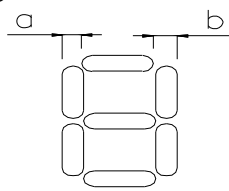
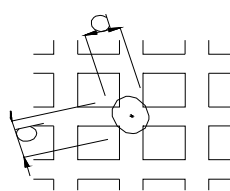
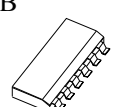
No.	Item	Criteria																												
5	Black spot, White spot, dust	<p>1b. Pin hole on dot matrix display</p>  <table border="1" style="margin-left: auto; margin-right: auto;"> <thead> <tr> <th colspan="2">Acceptable quantity</th> </tr> <tr> <th>Size</th> <th></th> </tr> </thead> <tbody> <tr> <td>$a, b < 0.1$</td> <td>Any number</td> </tr> <tr> <td>$(a+b)/2 \le 0.1$</td> <td>Any number</td> </tr> <tr> <td>$0.5 < \Phi < 1.0$</td> <td style="text-align: center;">3</td> </tr> </tbody> </table> <p>2. Segments / dots with different width</p>  <table border="1" style="margin-left: auto; margin-right: auto;"> <thead> <tr> <th colspan="2">Acceptable</th> </tr> </thead> <tbody> <tr> <td>$a \geq b$</td> <td>$a/b \leq 4/3$</td> </tr> <tr> <td>$a < b$</td> <td>$a/b > 4/3$</td> </tr> </tbody> </table> <p>3. Alignment layer defect</p> <p>$\Phi = (a+b)/2$</p>  <table border="1" style="margin-left: auto; margin-right: auto;"> <thead> <tr> <th colspan="2">Acceptable quantity</th> </tr> <tr> <th>Size</th> <th></th> </tr> </thead> <tbody> <tr> <td>$\Phi \leq 0.4$</td> <td>Any number</td> </tr> <tr> <td>$0.4 < \Phi \leq 1.0$</td> <td style="text-align: center;">5</td> </tr> <tr> <td>$1.0 < \Phi \leq 1.5$</td> <td style="text-align: center;">3</td> </tr> <tr> <td>$1.5 < \Phi \leq 2.0$</td> <td style="text-align: center;">2</td> </tr> </tbody> </table>	Acceptable quantity		Size		$a, b < 0.1$	Any number	$(a+b)/2 \le 0.1$	Any number	$0.5 < \Phi < 1.0$	3	Acceptable		$a \geq b$	$a/b \leq 4/3$	$a < b$	$a/b > 4/3$	Acceptable quantity		Size		$\Phi \leq 0.4$	Any number	$0.4 < \Phi \leq 1.0$	5	$1.0 < \Phi \leq 1.5$	3	$1.5 < \Phi \leq 2.0$	2
Acceptable quantity																														
Size																														
$a, b < 0.1$	Any number																													
$(a+b)/2 \le 0.1$	Any number																													
$0.5 < \Phi < 1.0$	3																													
Acceptable																														
$a \geq b$	$a/b \leq 4/3$																													
$a < b$	$a/b > 4/3$																													
Acceptable quantity																														
Size																														
$\Phi \leq 0.4$	Any number																													
$0.4 < \Phi \leq 1.0$	5																													
$1.0 < \Phi \leq 1.5$	3																													
$1.5 < \Phi \leq 2.0$	2																													
6	Colour uniformity	Level of sample for approval set as limit sample																												
7	Backlight	The backlight colour should correspond to the product specification Flashing and or unlit backlight is not allowed Dust larger than 0.25 mm is not allowed																												
8	COB	Exposed wire bond pad is not allowed Insufficient covering with resin is not allowed (wire bond line exposed) Dust or bubble on the resin are not allowed																												
9	PCB 	No unmelted solder paste should be present on PCB Cold solder joints, missing solder connections, or oxidation are not allowed No residue or solder balls on PCB are allowed Short circuits on components are not allowed																												
10	Tray particles	<table border="1" style="margin-left: auto; margin-right: auto;"> <thead> <tr> <th></th> <th>Size</th> <th>Quantity</th> </tr> </thead> <tbody> <tr> <td rowspan="2">On tray</td> <td>$\Phi < 0.2$</td> <td>Any number</td> </tr> <tr> <td>$\Phi > 0.25$</td> <td style="text-align: center;">4</td> </tr> <tr> <td rowspan="2">On display</td> <td>$\Phi \geq 0.25$</td> <td style="text-align: center;">2</td> </tr> <tr> <td>$L = 3$</td> <td style="text-align: center;">1</td> </tr> </tbody> </table>		Size	Quantity	On tray	$\Phi < 0.2$	Any number	$\Phi > 0.25$	4	On display	$\Phi \geq 0.25$	2	$L = 3$	1															
	Size	Quantity																												
On tray	$\Phi < 0.2$	Any number																												
	$\Phi > 0.25$	4																												
On display	$\Phi \geq 0.25$	2																												
	$L = 3$	1																												

13 HANDLING PRECAUTIONS

Safety

If the LCD panel breaks, be careful not to get the liquid crystal fluid in your mouth or in your eyes.
If the liquid crystal touches your skin or clothes, wash it off immediately using soap and plenty of water.

Mounting and Design

Place a transparent plate (e.g. acrylic, polycarbonate or glass) on the display surface to protect the display from external pressure. Leave a small gap between the transparent plate and the display surface.
When assembling with a zebra connector, clean the surface of the pads with alcohol and keep the surrounding air very clean. Design the system so that no input signal is given unless the power supply voltage is applied.

Caution during LCD cleaning

Lightly wipe the display surface with a soft cloth soaked with Isopropyl alcohol, Ethyl alcohol or Trichlorotrifluoroethane. Do not wipe the display surface with dry or hard materials that will damage the polariser surface. Do not use aromatic solvents (toluene and xylene), or ketonic solvents (ketone and acetone).

Caution against static charge

As the display uses C-MOS LSI drivers, connect any unused input terminal to VDD or VSS. Do not input any signals before power is turned on. Also, ground your body, work/assembly table and assembly equipment to protect against static electricity.

Packaging

Displays use LCD elements, and must be treated as such. Avoid strong shock and drop from a height.
To prevent displays from degradation, do not operate or store them exposed directly to sunshine or high temperature/humidity.

Caution during operation

It is indispensable to drive the display within the specified voltage limit since excessive voltage shortens its life. Direct current causes an electrochemical reaction with remarkable deterioration of the display quality. Give careful consideration to prevent direct current during ON/OFF timing and during operation.
Response time is extremely delayed at temperatures lower than the operating temperature range while, at high temperatures, displays become dark. However, this phenomenon is reversible and does not mean a malfunction or a display that has been permanently damaged. If the display area is pushed on hard during operation, some graphics will be abnormally displayed but returns to a normal condition after turning off the display once. Even a small amount of condensation on the contact pads (terminals) can cause an electrochemical reaction which causes missing rows and columns. Give careful attention to avoid condensation.

Storage

Store the display in a dark place where the temperature is $25^{\circ}\text{C} \pm 10^{\circ}\text{C}$ and the humidity below 50%RH.
Store the display in a clean environment, free from dust, organic solvents and corrosive gases.
Do not crash, shake or jolt the display (including accessories).

Product No.	LR2230	REV. A
-------------	--------	--------

Page	20 / 20
------	---------