

Insulated Enclosure KO 4763

with box terminals

for solder or plug-in technology



- Width 45 mm
- Max. 16 box-terminals with captive plus-minus-screws
- Electrical connection from PCB to terminal in solder or plug-in technology
- Mounting of SMD components possible on soldering side
- Available with removable terminal strips
- Available with changeable plate
- Spacer for PCB coding
- With changeable print area

Technical Data

Order references:

Front colour	beige	light grey RAL 7035	blue RAL 5015	Enclosure version with
Machine soldering				
KO 4763.120.16.04	.000	.007	.010	front plate
KO 4763.120.16.04	.001	.008	.011	plate
KO 4763.120.16.04	.002	.009	.012	plate clear
Solder technology with soldering lug				
KO 4763.120.16.04	.025	.028	.031	front plate
KO 4763.120.16.04	.026	.029	.032	plate
KO 4763.120.16.04	.027	.030	.033	plate clear
Plug-in technology with terminal plate				
KO 4763.120.16.03	.001	.002	.007	front plate
KO 4763.120.16.03	.004	.009	.011	plate
KO 4763.120.16.03	.005	.010	.012	plate clear
Plug-in technology with removable terminal strip				
KO 4763.120.16.05	.000	.003	.006	front plate
KO 4763.120.16.05	.001	.004	.007	plate
KO 4763.120.16.05	.002	.005	.008	plate clear

Outer dimensions: 45 x 73,5 x 118,2 mm

Enclosure material: PC-GF, base black,
front colour see table

Temperature stability:		
complying with UL 746 B:		125 °C
complying with Vicat		
ISO 306	Meth. B:	148 °C
compl. with ISO 75-2	Meth. A:	138 °C
	Meth. B:	144 °C

Max. permitted power dissipation: 15 W for stand-alone enclosure
at normal climate 23/50-1 ISO 554

specific thermal resistance: $R_{th} = 6.5 \text{ K} / \text{W}$ for stand-alone enclosure

Flame retardancy:
complying with UL 94: V-0; plate clear = V-2

Number of terminals: 16; < 16 on request

Contact material
Solder technology: CuSn tin-plated
Plug-in technology: CuBe tin-plated

Max. cross section for connection: max. 1 x 2.5 mm² stranded ferruled DIN 46 228-1/-2/-3/-4
max. 1 x 4 mm² solid
max 2 x 1.5 mm² stranded ferruled DIN 46 228-1/-2/-3/-4
min. \varnothing 0.1 mm

Insulation of wires length: 10 mm

**Max. contact resistance
to printed circuit board:** 10 m Ω

Max. current carrying capacity:
Solder technology: 16 A
Plug-in technology: 10 A

Wire fastening: captive plus-minus-terminal screws M3.5
box terminals with self raising wire protection

Torque: max. 0.8 Nm

Inner connection:
Solder technology: machine soldered bedded solder pins, available
with straight solder pins for horizontal PCB or
with soldering lug for wiring connection or

Plug-in technology: direct connection of PCB

Enclosure fastener: 1) Snap-on fastener on top hat rail IEC/EN 60 715
2) Screw fixing as special version
M4-grid 35 x 5
M5-grid 35 x 60 by Adapter ET 4762-5

Creepage current resistance: CTI 175 \cong insulated material III a IEC 60 664-1

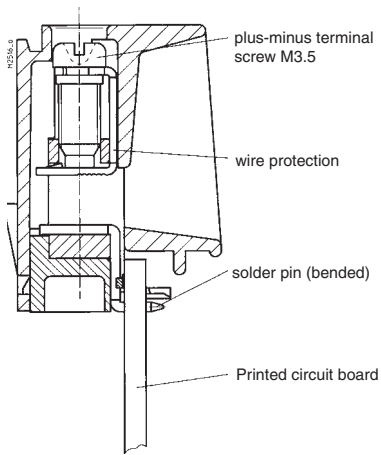

Box terminal for machine soldering

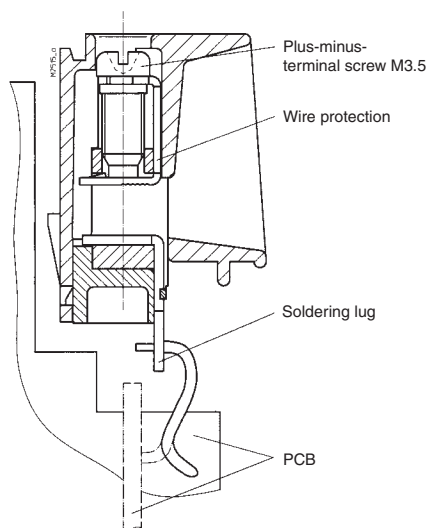

Box terminal for soldering with soldering lug

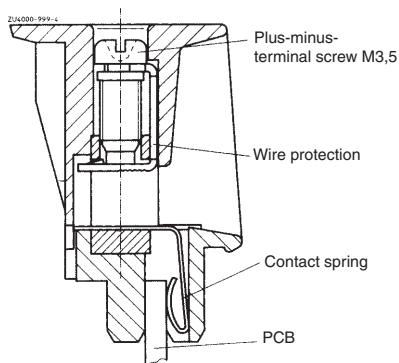

Box terminal for plug-in technology

Air gap and creepage distance: ≥ 3.3 mm

IEC 60 664-1

Type of protection:

Enclosure IP 40

IEC 60 529

Terminals IP 20

IEC 60 529

contact protection complies with VBG 4

Print area:

45 x 43 mm (on front plate)

Printed circuit board:

33 / 22 cm²

Printed circuit board holder:

Guide ribs on the small side

Guide ribs on the wide side

Accessories:

ET 4762-5:

Adapter

Solder technology:

KO 4721-7-1.24:

Blanking plug clear

Plug-in technology:

KO 4721-7-1.22:

Blanking plug clear

KO 4721-8-1:

Spacer for PCB coding

Machine solder technology

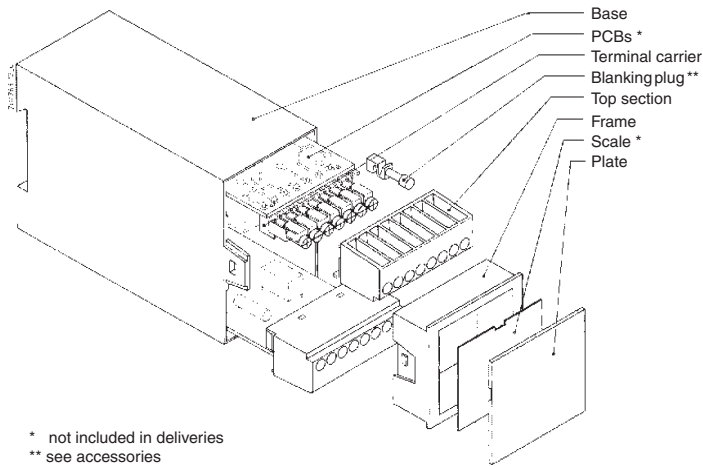

* not included in deliveries
** see accessories

Solder technology with soldering lug

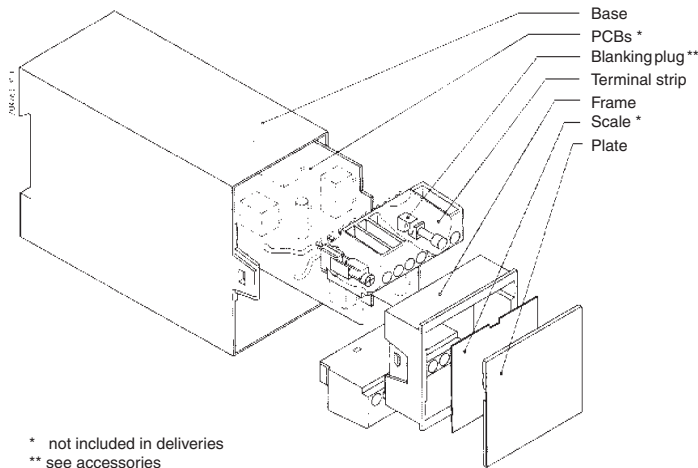

* not included in deliveries
** see accessories

Printed circuit board design for machine solder technology and solder technology with soldering lug

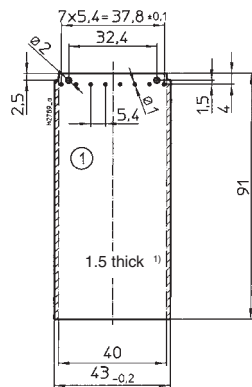
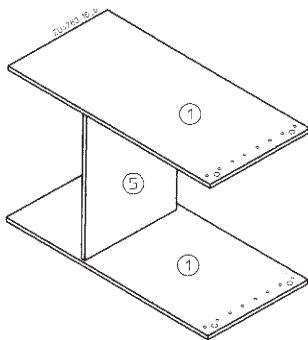

① Machine solderable vertical PCB

⑤ Horizontal PCB soldered between vertical PCBs

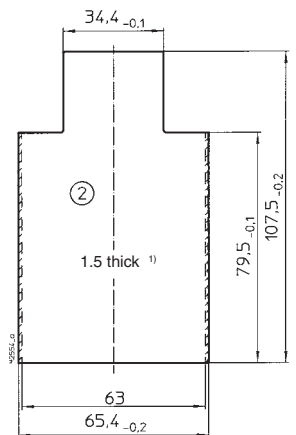
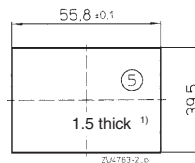

inhibited surface

¹⁾ Tolerance according to IEC 60 249-2-4
General tolerance: PERFAG E2

Applicable for solder technology with soldering lug only

Dimensions

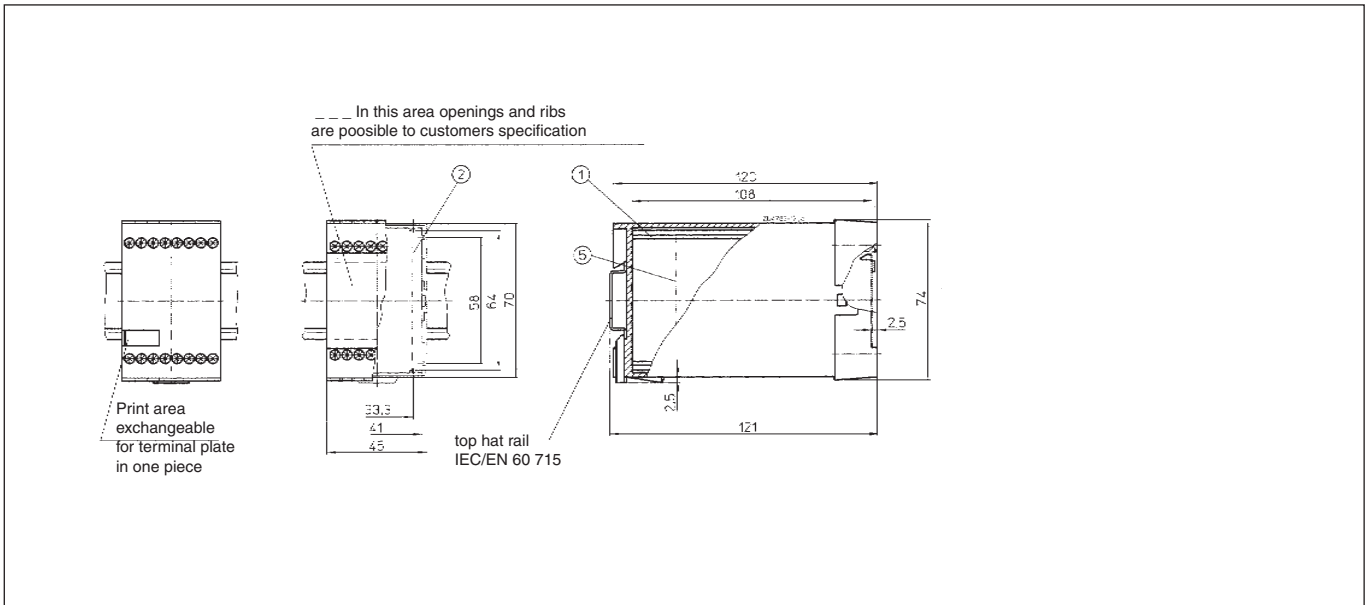

Plug-in technology with pluggable terminal plate

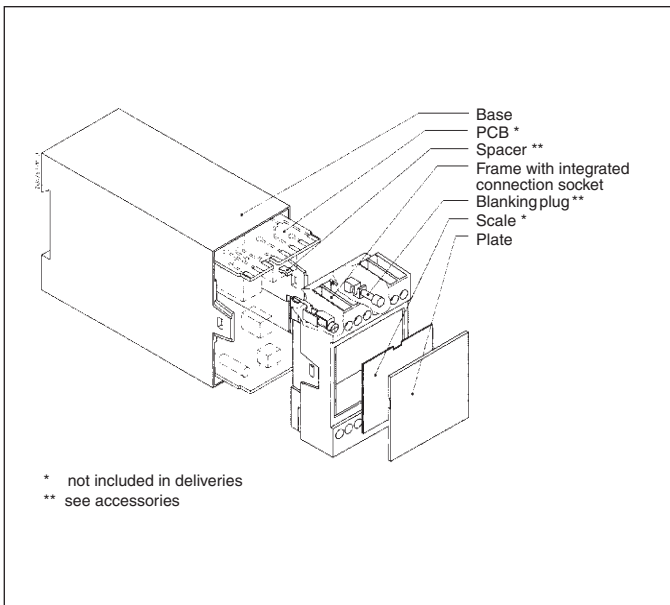

Plug-in technology with removable terminal strip

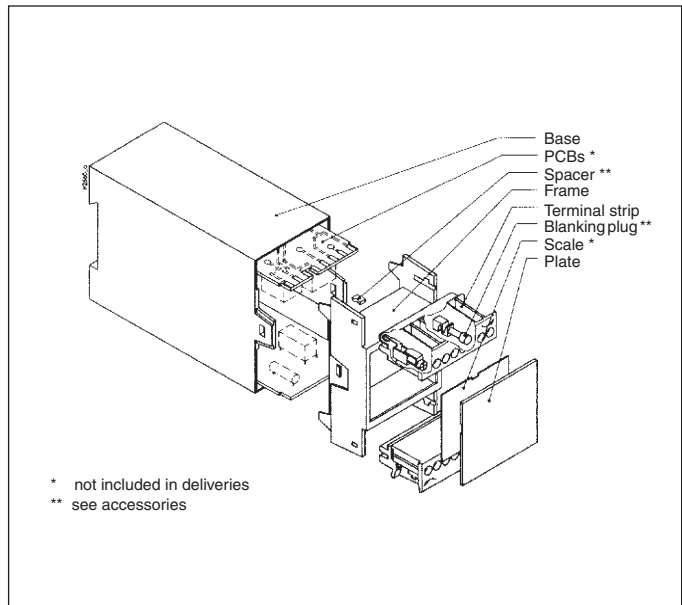

Printed circuit board design for plug-in technology

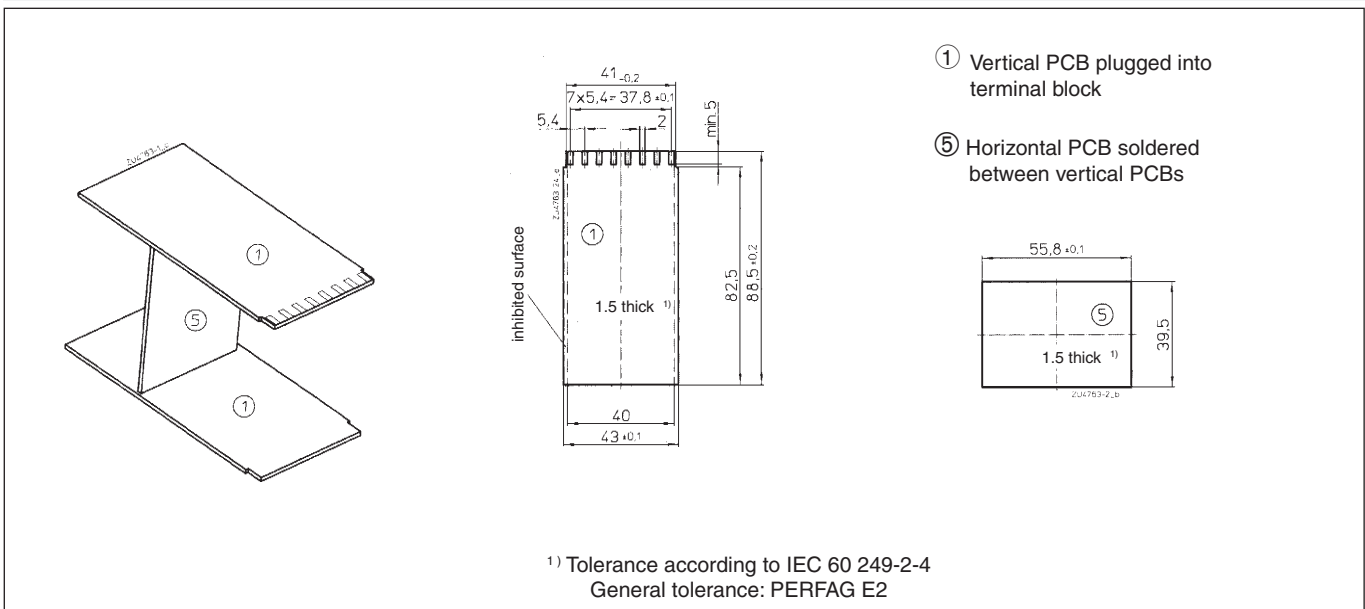

Notes on Housing Opening

1. Tool

- for all functions use 0.8 x 4.0 or 0.8 x 4.5 screwdriver

2. Removing of frame

- Insert a screwdriver in the side recesses of the base (underneath)
- With light pressure, turn the screwdriver to the left or right.
- The snap-in lug of the frame disengages.
- Repeat disengaging process on opposite side.
- The frame can be removed.

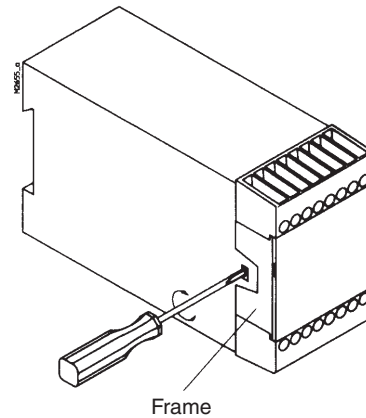

Notes on Housing Opening Installation with pluggable terminal plate

1. Tool

- for all functions use 0.8 x 4.0 or 0.8 x 4.5 screwdriver

2. Removing of terminal plate

- Insert a screwdriver in the side recesses of the base (underneath)
- With light pressure, turn the screwdriver to the left or right.
- The snap-in lug of the terminal plate disengages.
- Repeat disengaging process on opposite side.
- Terminal plate can be removed.

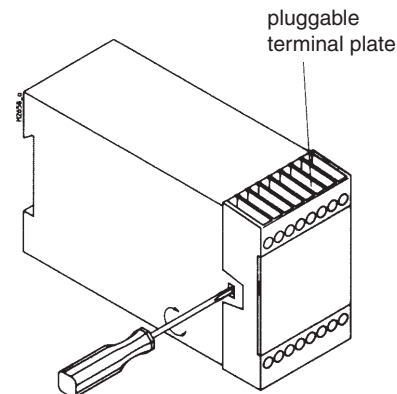

3. Demontage der Platte

- Insert a screwdriver in the side recesses of the plate
- With light pressure, turn the screwdriver to the left or right.
- Plate disengages and can be removed.

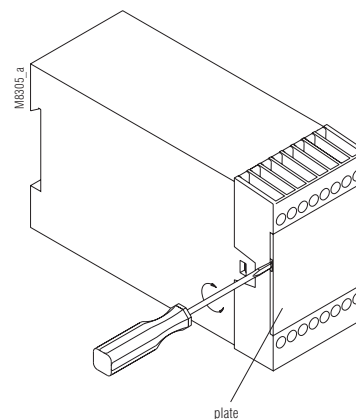

Notes on Housing Opening Installation - removable terminal strip

1. Tool

- for all functions use 0.8 x 4.0 or 0.8 x 4.5 screwdriver

2. Removing of terminal strip

- Insert a screwdriver between terminal strip and front frame
- Unclip the terminal strip by suriveling the screwdriver in the direction of the lug.
- Terminal strip can be removed

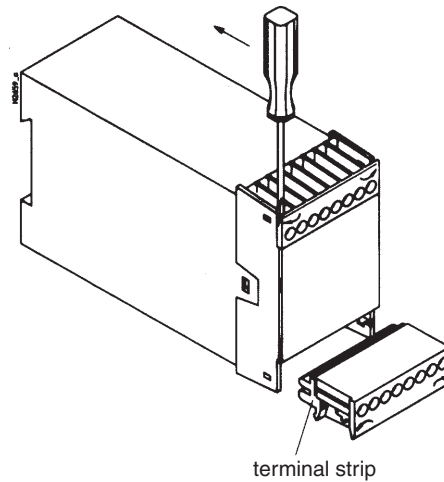

3. Removing of frame

- Insert a screwdriver in the side recesses of the base (underneath)
- With light pressure, turn the screwdriver to the left or right.
- The snap-in lug of the frame disengages.
- Repeat disengaging process on opposite side.
- The frame can be removed.

