

LIQUID CRYSTAL DISPLAY MODULE

Product Specification

CUSTOMER	Standard	
PRODUCT NUMBER	LMRD4165/LMRD3165	
CUSTOMER APPROVAL		Date 12th June 2008

INTERNAL APPROVALS		
Product Mgr	Doc Control	Electr. Eng
Elijah Ebo	Anthony Perkins	Bazile Peter
Date: 12/06/08	Date: 12/06/08	Date: 12/06/08

- Approval for Specification only
- Approval for Specification and Sample

TABLE OF CONTENTS

1	MAIN FEATURES	4
2	MECHANICAL SPECIFICATION.....	5
2.1	MECHANICAL CHARACTERISTICS	5
2.2	MECHANICAL DRAWING	6
3	ELECTRICAL SPECIFICATION.....	7
3.1	ABSOLUTE MAXIMUM RATINGS	7
3.2	ELECTRICAL CHARACTERISTICS	7
3.3	INTERFACE PIN ASSIGNMENT LMRD3165.....	9
3.4	INTERFACE PIN ASSIGNMENT LMRD4165.....	10
4	BLOCK DIAGRAM	11
4.1	POWER SUPPLY CIRCUIT	11
4.2	CHARACTER GENERATOR ROM MAP	12
5	TIMING CHARECTERISTICS.....	13
5.1	READ/WRITE TIMING	13
6	OPTICAL SPECIFICATION.....	15
6.1	OPTICAL CHARACTERISTICS.....	15
7	BACKLIGHT SPECIFICATION	17
7.1	BACKLIGHT CHARACTERISTICS.....	17
7.2	LABELLING & MARKING.....	18
8	QUALITY ASSURANCE SPECIFICATION.....	19
8.1	CONFORMITY	19
8.2	DELIVERY ASSURANCE	19
8.3	DEALING WITH CUSTOMER COMPLAINTS	24
9	RELIABILITY SPECIFICATION	25
9.1	RELIABILITY TESTS	25
9.2	LIFE TIME.....	25
10	PART NUMBER DESCRIPTIONS FOR AVAILABLE OPTIONS.....	26

Product No.	LMRD4165/LMRD3165	REV. B
		REV.

Page	2 / 27
------	--------

REVISION RECORD

Rev.	Date	Page	Chapt.	Comment	ECR no.
A	27/02/97			Product release	E0505
B	12/06/08			Line Driver changed to Neotec NT7086	

Product No.	LMRD4165/LMRD3165	REV. B
		REV.

Page	3 / 27
------	--------

1 MAIN FEATURES

ITEM	CONTENTS
Display Format	128 x 128 dots
Overall Dimensions	88.0 x 88.0 x 10.8 mm (EL type without NVTC) 88.0 x 88.0 x 13.8 mm (EL type with NVTC) 88.0 x 88.0 x 16.3 mm (Array LED type without NVTC) 88.0 x 88.0 x 19.3 mm (Array LED type with NVTC)
Viewing Area	69.0 x 69.0 mm
LCD type	STN
Mode	Reflective or Transflective
Viewing Angle	6 O clock
Duty ratio	1 / 128
Driver IC	Sanyo LC7981
Backlight type	EL / LED
Backlight colour	Array LED – Yellow Green EL - White
DC/DC converter	Optional
Operating temperature normal	0 ~ +50°C
Operating temperature wide	-20 ~ + +70°C
Storage temperature normal	-20 ~ + +70°C
Storage temperature wide	-30 ~ +80°C
RoHS status	Compliant

* NVTC: Negative voltage generator and temperature compensation

Product No.	LMRD4165/LMRD3165	REV. B
		REV.

Page	4 / 27
------	--------

2 MECHANICAL SPECIFICATION

2.1 MECHANICAL CHARACTERISTICS

ITEM	CHARACTERISTIC	UNIT
Display Format	128 x 128	
Overall Dimensions	88.0 x 88.0 x 10.8 (EL type without NVTC) 88.0 x 88.0 x 13.8 (EL type with NVTC) 88.0 x 88.0 x 16.3 (Array LED type without NVTC) 88.0 x 88.0 x 19.3 (Array LED type with NVTC)	mm
Viewing Area	69.0 x 69.0	mm
Active Area	63.96 x 63.96	mm
Dot Size	0.46 x 0.46	mm
Dot Pitch	0.04	mm
IC Controller/Driver	Sanyo LC7981	

Product No.	LMRD4165/LMRD3165	REV. B
		REV.

Page	5 / 27
------	--------

2.2 MECHANICAL DRAWING

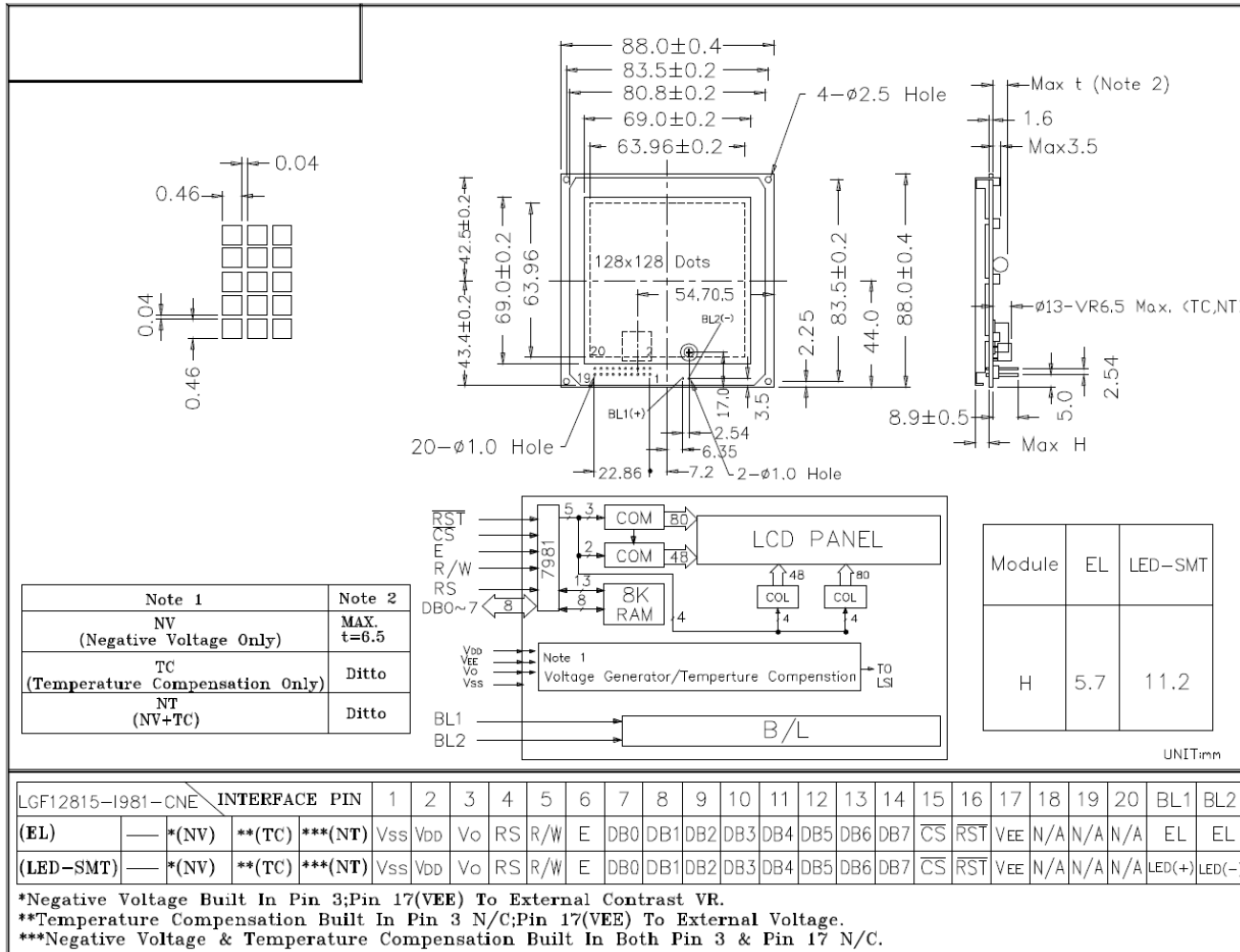

3 ELECTRICAL SPECIFICATION

3.1 ABSOLUTE MAXIMUM RATINGS

Ta = 25 °C

Item	Symbol	Min	Max	Unit	Note
Power Supply Voltage	V _{DD}	0	7	V	50 ± 10% RH
Operating Temperature normal	T _{opr}	0	50	°C	Note 1
Operating Temperature wide		-20	+70		
Storage Temperature normal	T _{stg}	-20	+70	°C	Note 2
Storage Temperature wide		-30	+80		
		20	90	%RH	<48 hrs
		20	65		< 1000 hrs
Static Electricity	Be sure that you are grounded when handling displays.				

Note 1: Background colour changes slightly depending on ambient temperature. This phenomenon is reversible. Ta ≤ 70 °C: 75% RH max

Note 2: Ta ≤ 80 °C: 75% RH max

3.2 ELECTRICAL CHARACTERISTICS

VSS = 0 V, Ta = 25 °C

Item	Symbol	Condition	Min	Typ	Max	Unit
Operating Voltage	V _{DD}		4.75	-	5.25	V
Input Voltage	Low V _{ILc}		0	-	0.2V _{DD}	V
	High V _{IHc}		0.8 V _{DD}	-	V _{DD}	V
LCD Driving Voltage	V _{DD} - V _O		12	V	28.0	V

3.2.1 Current Consumption & Driving Voltage

		FSTN		STN	
		Normal	Wide	Normal	Wide
Supply current, (I _{DD}) Max, mA		N/A	N/A	10.5	10.5
Supply current (I _{EE}) Typ, mA		N/A	N/A	3.5	3.5
Recommended LCD drive voltage					
LCD driving voltage	Ta = -20°C	N/A	N/A	N/A	23.8
	Ta = 0°C	N/A	N/A	22.1	22.1
	Ta = 25°C	N/A	N/A	20.0	20.0
	Ta = 50°C	N/A	N/A	17.2	17.2
	Ta = 70°C	N/A	N/A	N/A	14.7

Note: 1. The V_{EE} can't be over -23V
2: The I_{DD} is 85mA when building NV or NVTC

Product No.	LMRD4165/LMRD3165	REV. B
		REV.

Page	8 / 27
------	--------

3.3 INTERFACE PIN ASSIGNMENT LMRD3165

No.	Symbol	Function
1	V _{SS}	Ground
2	V _{DD}	Power supply for logic
3	V _O	Voltage Level for LCD Control Adjustment
4	RS	Register Select Signal
5	R/W	WRITE MODE H: Command Write L:Data Write READ MODE H:Status Read L:Data Read
6	E	Enable Signal
7~14	DB0~DB7	Display Data 0~7
15	/CS	Chip Select Signal
16	/RST	Reset Signal
17	V _{ee}	Power supply for LCD drive
18	NC	No Connection
19	NC	No Connection
20	NC	No connection
BL1	EL	EL
BL2	EL	EL

Product No.	LMRD4165/LMRD3165	REV. B
		REV.

Page	9 / 27
------	--------

3.4 INTERFACE PIN ASSIGNMENT LMRD4165

No.	Symbol	Function
1	V _{SS}	Ground
2	V _{DD}	Power supply for logic
3	V _O	Voltage Level for LCD Control Adjustment
4	RS	Register Select Signal
5	R/W	WRITE MODE H: Command Write L:Data Write READ MODE H:Status Read L:Data Read
6	E	Enable Signal
7~14	DB0~DB7	Display Data 0~7
15	/CS	Chip Select Signal
16	/RST	Reset Signal
17	V _{ee}	Power supply for LCD drive
18	NC	No Connection
19	NC	No Connection
20	NC	No connection
BL1	LED(+)	Anode of LED backlight
BL2	LED(-)	Cathode of LED backlight

Product No.	LMRD4165/LMRD3165	REV. B
		REV.

Page	10 / 27
------	---------

4 BLOCK DIAGRAM

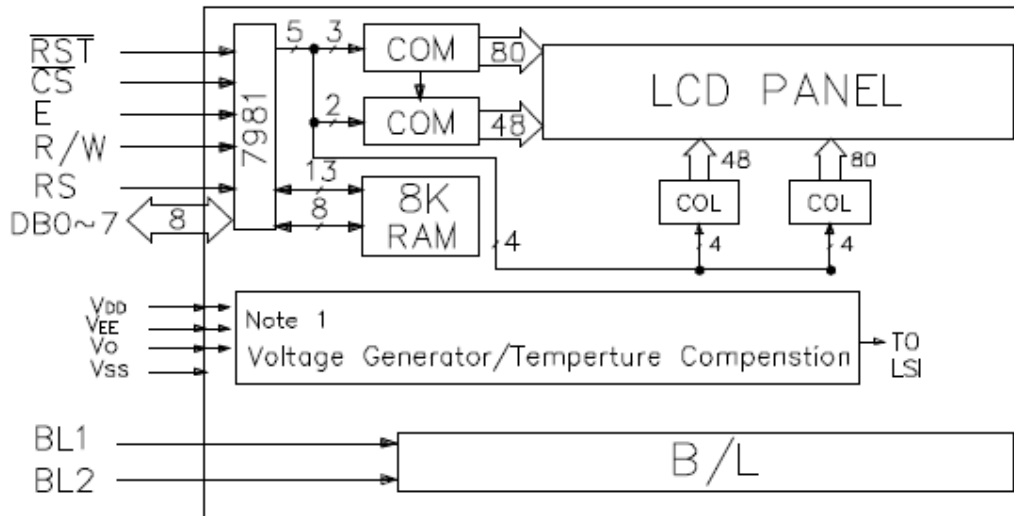

4.1 POWER SUPPLY CIRCUIT

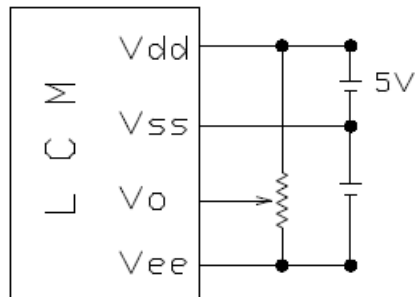

NEGATIVE VOLTAGE
NOT BUILT IN

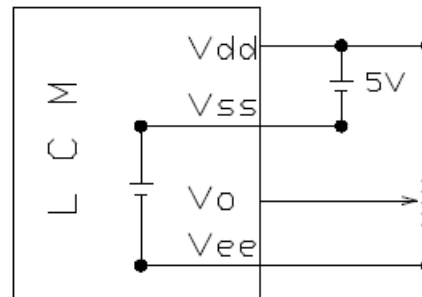

NEGATIVE VOLTAGE
BUILT IN

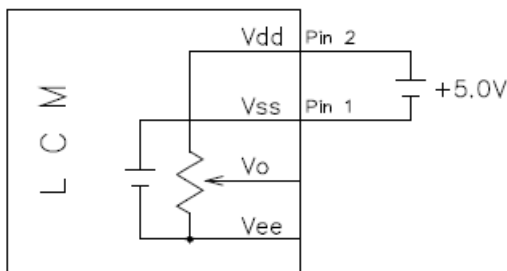

NEGATIVE VOLTAGE & TEMPERATURE
COMPENSATION BUILT IN

Product No.	LMRD4165/LMRD3165	REV. B
		REV.

Page	11 / 27
------	---------

4.2 CHARACTER GENERATOR ROM MAP

Upper 4-bit	0010	0011	0100	0101	0110	0111	1010	1011	1100	1101	1110	1111
xxxx0000	0	1	2	3	4	5	6	7	8	9	*	+
xxxx0001	!	"	#	\$	%	&	'	()	*	+	,
xxxx0010	A	B	C	D	E	F	G	H	I	J	K	L
xxxx0011	a	b	c	d	e	f	g	h	i	j	k	l
xxxx0100	1	2	3	4	5	6	7	8	9	0	.	/
xxxx0101	!	"	#	\$	%	&	'	()	*	+	,
xxxx0110	A	B	C	D	E	F	G	H	I	J	K	L
xxxx0111	a	b	c	d	e	f	g	h	i	j	k	l
xxxx1000	1	2	3	4	5	6	7	8	9	0	.	/
xxxx1001	!	"	#	\$	%	&	'	()	*	+	,
xxxx1010	A	B	C	D	E	F	G	H	I	J	K	L
xxxx1011	a	b	c	d	e	f	g	h	i	j	k	l
xxxx1100	1	2	3	4	5	6	7	8	9	0	.	/
xxxx1101	!	"	#	\$	%	&	'	()	*	+	,
xxxx1110	A	B	C	D	E	F	G	H	I	J	K	L
xxxx1111	a	b	c	d	e	f	g	h	i	j	k	l

5 TIMING CHARECTERISTICS

5.1 Read/Write Timing

Timing Characteristics

◆ Bus read/write operation 1

READ CYCLE



WRITE CYCLE

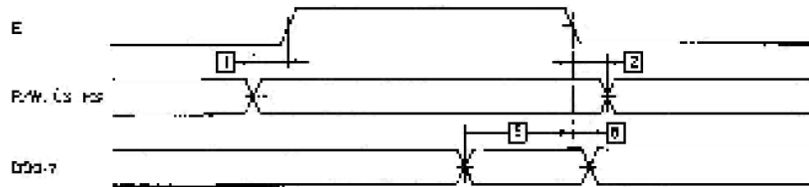

Ta = -20°C to +55°C, VDD = 5.0V ± 5%, VDDI = 0V

No.	Item	Symbol	min	typ	max	unit	Conditions
1	Address set-up time	tAS	80			ns	
2	Address hold time	tAH	10			ns	
3	Data delay time (read)	tDOR			140	ns	C _L = 50pF
4	Data hold time (read)	tDHR	10			ns	
5	Data set-up time (write)	tDSW	220			ns	
6	Data hold time (write)	tDHW	20			ns	

Note: Definition of the test waveform



The input terminals are driven at 2.4V and 0.45V. Timing is measured at 1.5V.

Product No.	LMRD4165/LMRD3165	REV. B
		REV.

Page	13 / 27
------	---------

• Bus read/write operation 2

DATA HEAD CYCLE

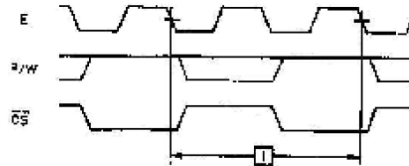

DATA WRITE CYCLE

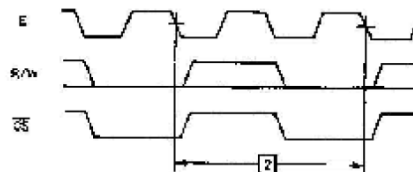

Ta = -20 to +75°C, VDD = 5 V ± 5%, GND = 0 V

No	Item	Symbol	min	typ	max	unit	Instruction register value
1	Read cycle time	tRCY			$\frac{(Hp + 2) \times 10^3}{Fosc} + 200$	ns	0 CH
2	Write cycle time	tWCY1			$\frac{(2 \cdot Hp - 2) \times 10^3}{Fosc} + 200$	ns	0 EH, 0 FH
2	Write cycle time	tWCY2			$\frac{(Hp + 2) \times 10^3}{Fosc} + 200$	ns	0 CH
2	Write cycle time	tWCY3			$\frac{2000}{Fosc} + 200$	ns	00H, 01H, 02H, 03H, 04H, 05H, 06H, 07H, 08H, 09H

- Notes: (1) In the character mode, Hp is the number of horizontal dots per character in a character display. In the graphic mode, Hp indicates how many bits from RAM appear in a 1-byte display.
 (2) FOSC is the oscillating frequency, expressed in MHz.
 (3) All measurement points are at 1.5V.

• Parallel operation (at master mode)

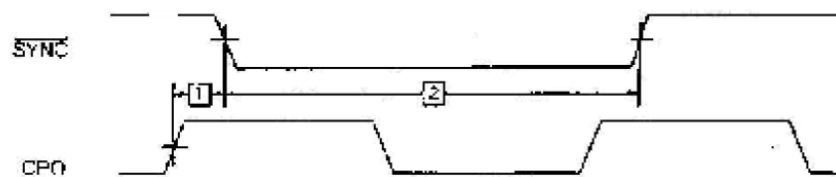

Ta = -20 to +75°C, VDD = 5 V ± 5%, GND = 0 V

No	Item	Symbol	min	typ	max	unit	Conditions
1	SYNC delay time	tDSY			100	ns	
2	SYNC pulse width	tWSY	350			ns	

- Notes: (1) All output terminals are under no load.
 (2) All measurement points are at 0.5VDD.

Product No.	LMRD4165/LMRD3165	REV. B
		REV.

Page	14 / 27
------	---------

6 OPTICAL SPECIFICATION

6.1 OPTICAL CHARACTERISTICS

6.1.1 STN Type

Ta = 25 °C

Item	Symbol	Condition	Min	Typ	Max	Unit	Note
Viewing Angle	θ1	CR≥2	-	30	-	deg	1
	θ2	CR≥2	-	20	-	deg	1
	θ3	CR≥2	-	30	-	deg	2
	θ4	CR≥2	-	30	-	deg	2
Contrast Ratio	CR	Ta = 25 °C	3	-	-	-	3
Response Time	Tr	Ta = 25 °C	-	-	300	ms	4
	Tf	Ta = 25 °C	-	-	300		
Driving Method	Duty	1/128					
	Bias	1/12					
LCD Type	STN – Positive / Transflective						
Viewing Direction	6 O’CLOCK						

Product No.	LMRD4165/LMRD3165	REV. B
		REV.

Page	15 / 27
------	---------

Note 1: definition of viewing angle θ_1 & θ_2

Note 2: definition of viewing angle θ_3 & θ_4

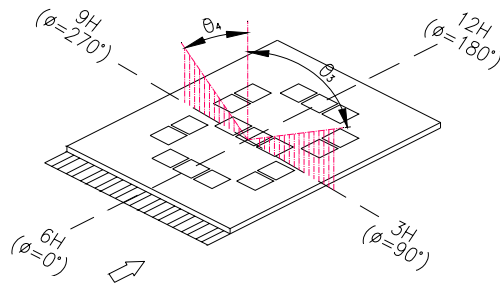
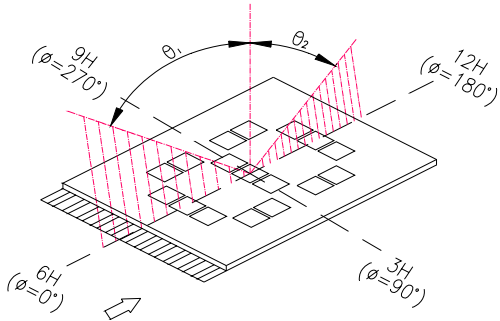

Note 3: definition of contrast ratio (CR)

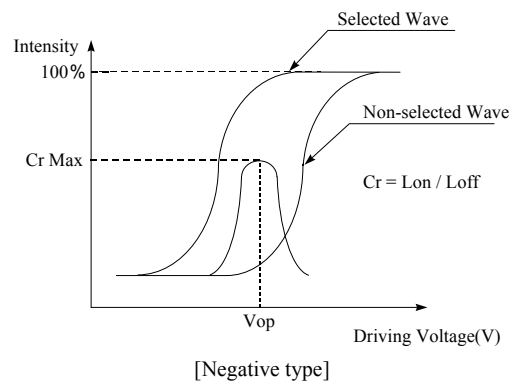
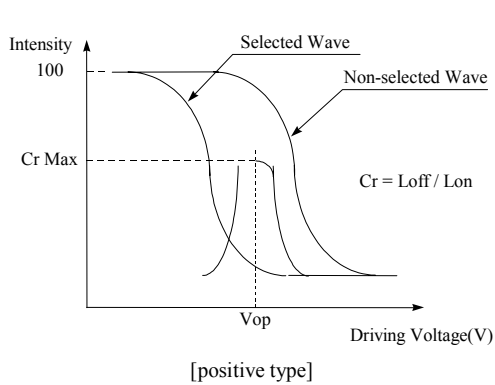

Note 4: definition of response time

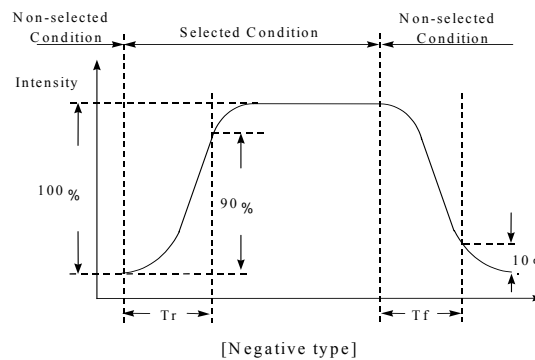
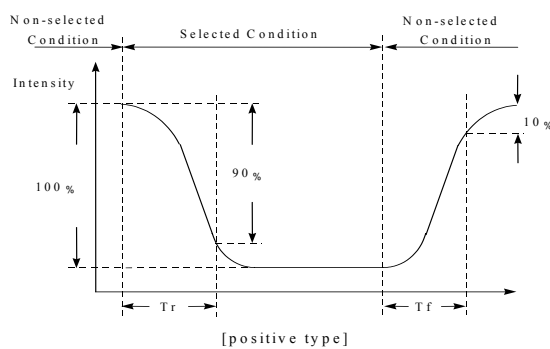

Product No.	LMRD4165/LMRD3165	REV. B
		REV.

Page	16 / 27
------	---------

7 BACKLIGHT SPECIFICATION

7.1 BACKLIGHT CHARACTERISTICS

7.1.1 LMRD3165 (EL)

Item	Condition	Min	Typ	Max	Unit
Input Voltage	Ta=25°C (400~800 Hz)		100		Vrms
Current consumption	Ta=25°C		12.0		mA
Average Brightness Ta=25°C I=12.0mA	Test when connecting after 3min. (max contrast) Ta=25°C		50		cd/m ² Note 1
Life time	Ta=25°C, I = 12.0 mA Humidity: 30% RH~85%RH		5000		Hrs Note 2
Operating temperature	Humidity: 30% RH~85% RH	-20		70	°C
Storage temperature	Humidity: 30% RH~85% RH	-30		80	°C

7.1.2 LMRD4165 (Array LED)

Item	Condition	Min	Typ	Max	Unit
Input Voltage	Ta=25°C		5.0		V(DC)
Current consumption	Ta=25°C		380		mA
Average Brightness Ta=25°C IL=380mA	Test when connecting after 3min. (max contrast) Ta=25°C		125		cd/m ² Note 1
Brightness Uniformity	Ta=25°C, IL = 380mA	80			% Note 2
Life time	Ta=25°C, IL= 380 mA Humidity: 30% RH~85%RH		50000		Hrs Note 3
Operating temperature	Humidity: 30% RH~85% RH	-20		70	°C
Storage temperature	Humidity: 30% RH~85% RH	-30		80	°C
Limit Resistor	Ta=25°C		2.9		OHM Note 4

Product No.	LMRD4165/LMRD3165	REV. B
		REV.

Page	17 / 27
------	---------

Note:

1. Average brightness of 3 points when the B/L is used at the beginning.
2. Brightness uniformity = (MAX-MIN) / MAX x 100
3. Half of the original brightness
4. Suggested BL current limit resistor on customer board

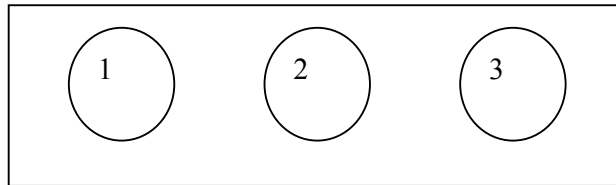
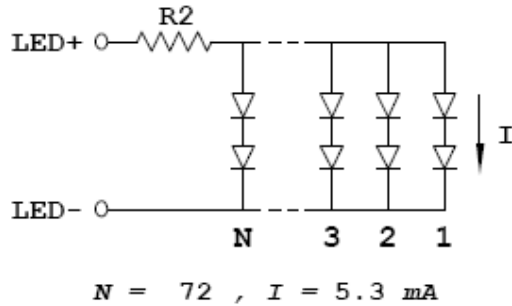

7.2 LABELLING & MARKING

DENSITRON
LMRD3165 or LMRD4165
Taiwan YYMM

Product No.	LMRD4165/LMRD3165	REV. B
		REV.

Page	18 / 27
------	---------

8 QUALITY ASSURANCE SPECIFICATION

8.1 CONFORMITY

The performance, function and reliability of the shipped products conform to the Product Specification.

8.2 DELIVERY ASSURANCE

8.2.1 Delivery inspection standards

- MIL-STD-105E, general inspection level II, single sampling level;
- IPC-AA610 rev. C, class 2 electronic assemblies standard

The quality assurance levels are shown below:

Class	AQL (%)
Critical defect	0.65%
Major defect	1.0%
Minor defect	2.5%
TOTAL	2.5%

8.2.2 Zone definition

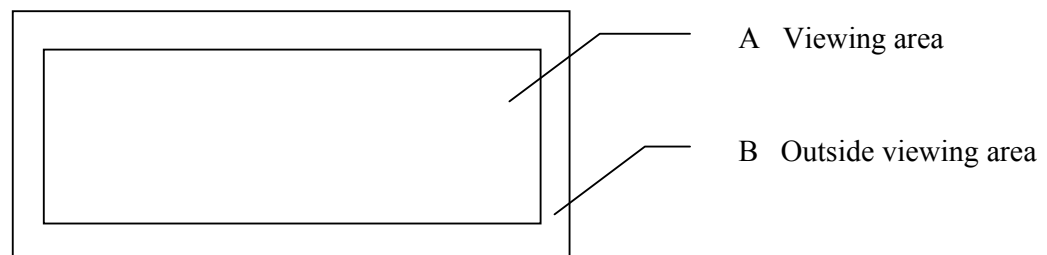

Product No.	LMRD4165/LMRD3165	REV. B
		REV.

Page	19 / 27
------	---------

8.2.3 Visual inspection

- Inspect under 2x20W or 40W fluorescent lamp (approximately 3000 lux) leaving 25 to 30 cm between the module and the lamp and 30 cm between the module and the eye (measuring position).
- Appearance is inspected at the best contrast voltage (best contrast is adjusted considering clearness and crosstalk on screen).
- Inspect the module at 45° right and left, top and bottom.
- Use the optimum viewing angle during the contrast inspection.

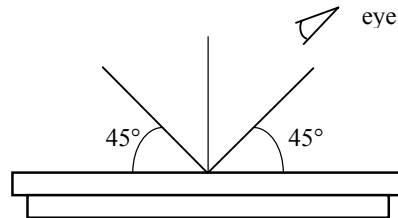

Product No.	LMRD4165/LMRD3165	REV. B
		REV.

Page	20 / 27
------	---------

8.2.3.1 Standard of appearance inspection

Units: mm

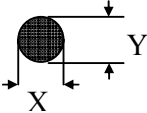
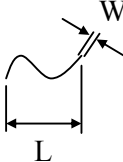
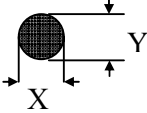
Class	Item	Criteria																																			
Minor	Packing & Label	Outside & inside package Presence of product no., lot no., quantity																																			
Critical		Product must not be mixed with others and quantity must not be different from that indicated on the label																																			
Major	Dimension	Product dimensions must be according to specification and drawing																																			
Major	Electrical	Product electrical characteristics must be according to specification																																			
Critical	LCD Display	Missing lines or wrong patterns on LCD display are not allowed																																			
Minor	Black spot, white spot, dust	<p>Round type: as per following drawing $\varnothing = (X+Y)/2$</p>  <table border="1" style="margin-left: auto; margin-right: auto;"> <thead> <tr> <th colspan="3">Acceptable quantity</th> </tr> <tr> <th>Size</th> <th>Zone A</th> <th>Zone B</th> </tr> </thead> <tbody> <tr> <td>$\varnothing < 0.1$</td> <td>Any number</td> <td rowspan="4">Any number</td> </tr> <tr> <td>$0.1 < \varnothing < 0.2$</td> <td>2</td> </tr> <tr> <td>$0.2 < \varnothing < 0.25$</td> <td>1</td> </tr> <tr> <td>$0.25 < \varnothing$</td> <td>0</td> </tr> </tbody> </table> <p>Line type: as per following drawing</p>  <table border="1" style="margin-left: auto; margin-right: auto;"> <thead> <tr> <th colspan="4">Acceptable quantity</th> </tr> <tr> <th>Length</th> <th>Width</th> <th>Zone A</th> <th>Zone B</th> </tr> </thead> <tbody> <tr> <td>--</td> <td>$W \leq 0.02$</td> <td>Any number</td> <td rowspan="4">Any number</td> </tr> <tr> <td>$L \leq 3.0$</td> <td>$0.02 < W \leq 0.03$</td> <td rowspan="2">2</td> </tr> <tr> <td>$L \leq 2.5$</td> <td>$0.03 < W \leq 0.05$</td> </tr> <tr> <td>--</td> <td>$0.05 < W$</td> <td>As round type</td> </tr> </tbody> </table> <p style="text-align: center;">Total acceptable quantity: 3</p>	Acceptable quantity			Size	Zone A	Zone B	$\varnothing < 0.1$	Any number	Any number	$0.1 < \varnothing < 0.2$	2	$0.2 < \varnothing < 0.25$	1	$0.25 < \varnothing$	0	Acceptable quantity				Length	Width	Zone A	Zone B	--	$W \leq 0.02$	Any number	Any number	$L \leq 3.0$	$0.02 < W \leq 0.03$	2	$L \leq 2.5$	$0.03 < W \leq 0.05$	--	$0.05 < W$	As round type
Acceptable quantity																																					
Size	Zone A	Zone B																																			
$\varnothing < 0.1$	Any number	Any number																																			
$0.1 < \varnothing < 0.2$	2																																				
$0.2 < \varnothing < 0.25$	1																																				
$0.25 < \varnothing$	0																																				
Acceptable quantity																																					
Length	Width	Zone A	Zone B																																		
--	$W \leq 0.02$	Any number	Any number																																		
$L \leq 3.0$	$0.02 < W \leq 0.03$	2																																			
$L \leq 2.5$	$0.03 < W \leq 0.05$																																				
--	$0.05 < W$	As round type																																			
Minor	Polariser scratch	Scratch on protective film is permitted Scratch on polariser: same as No. 1																																			
Minor	Polariser bubble	<p>$\varnothing = (X+Y)/2$</p>  <table border="1" style="margin-left: auto; margin-right: auto;"> <thead> <tr> <th colspan="3">Acceptable quantity</th> </tr> <tr> <th>Size</th> <th>Zone A</th> <th>Zone B</th> </tr> </thead> <tbody> <tr> <td>$\varnothing < 0.2$</td> <td>Any number</td> <td rowspan="4">Any number</td> </tr> <tr> <td>$0.2 < \varnothing < 0.5$</td> <td>2</td> </tr> <tr> <td>$0.5 < \varnothing < 1.0$</td> <td>1</td> </tr> <tr> <td>$1.0 < \varnothing$</td> <td>0</td> </tr> </tbody> </table> <p style="text-align: center;">Total acceptable quantity: 3</p>	Acceptable quantity			Size	Zone A	Zone B	$\varnothing < 0.2$	Any number	Any number	$0.2 < \varnothing < 0.5$	2	$0.5 < \varnothing < 1.0$	1	$1.0 < \varnothing$	0																				
Acceptable quantity																																					
Size	Zone A	Zone B																																			
$\varnothing < 0.2$	Any number	Any number																																			
$0.2 < \varnothing < 0.5$	2																																				
$0.5 < \varnothing < 1.0$	1																																				
$1.0 < \varnothing$	0																																				

Product No.	LMRD4165/LMRD3165	REV. B
		REV.

Page	21 / 27
------	---------

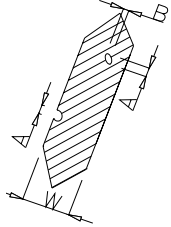
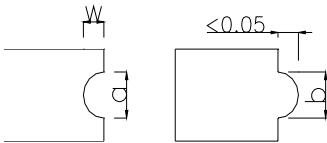
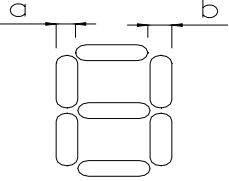
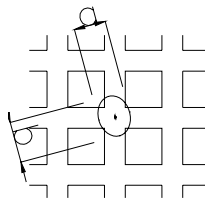
Class	Item	Criteria																												
Minor	Segment deformation	<p>1.a. Pin hole on segmented display</p> <p>W: segment width $\varnothing = (A+B)/2$</p>  <table border="1" style="margin-left: auto; margin-right: auto;"> <thead> <tr> <th colspan="2">Acceptable quantity</th> </tr> <tr> <th>Width</th> <th>\varnothing</th> </tr> </thead> <tbody> <tr> <td>$W \leq 0.4$</td> <td>$\varnothing \leq 0.2$ and $\varnothing \leq 1/2W$</td> </tr> <tr> <td>$W > 0.4$</td> <td>$\varnothing \leq 0.25$ and $\varnothing \leq 1/3W$</td> </tr> </tbody> </table> <p>Total acceptable quantity: 1 defect per segment Pin holes with \varnothing under 0.10 mm are acceptable</p>	Acceptable quantity		Width	\varnothing	$W \leq 0.4$	$\varnothing \leq 0.2$ and $\varnothing \leq 1/2W$	$W > 0.4$	$\varnothing \leq 0.25$ and $\varnothing \leq 1/3W$																				
Acceptable quantity																														
Width	\varnothing																													
$W \leq 0.4$	$\varnothing \leq 0.2$ and $\varnothing \leq 1/2W$																													
$W > 0.4$	$\varnothing \leq 0.25$ and $\varnothing \leq 1/3W$																													
Minor	Segment deformation	<p>1b. Pin hole on dot matrix display</p>  <table border="1" style="margin-left: auto; margin-right: auto;"> <thead> <tr> <th colspan="2">Acceptable quantity</th> </tr> <tr> <th>Size</th> <th></th> </tr> </thead> <tbody> <tr> <td>$a, b < 0.1$</td> <td>Any number</td> </tr> <tr> <td>$(a+b)/2 \leq 0.1$</td> <td>Any number</td> </tr> <tr> <td>$0.5 < \varnothing < 1.0$</td> <td>3</td> </tr> </tbody> </table> <p>Total acceptable quantity: 7</p> <p>2. Segments / dots with different width</p>  <table border="1" style="margin-left: auto; margin-right: auto;"> <thead> <tr> <th colspan="2">Acceptable</th> </tr> </thead> <tbody> <tr> <td>$a \geq b$</td> <td>$a/b \leq 4/3$</td> </tr> <tr> <td>$a < b$</td> <td>$a/b > 4/3$</td> </tr> </tbody> </table> <p>3. Alignment layer defect</p> <p>$\varnothing = (a+b)/2$</p>  <table border="1" style="margin-left: auto; margin-right: auto;"> <thead> <tr> <th colspan="2">Acceptable quantity</th> </tr> <tr> <th>Size</th> <th></th> </tr> </thead> <tbody> <tr> <td>$\varnothing \leq 0.4$</td> <td>Any number</td> </tr> <tr> <td>$0.4 < \varnothing \leq 1.0$</td> <td>5</td> </tr> <tr> <td>$1.0 < \varnothing \leq 1.5$</td> <td>3</td> </tr> <tr> <td>$1.5 < \varnothing \leq 2.0$</td> <td>2</td> </tr> </tbody> </table> <p>Total acceptable quantity: 7</p>	Acceptable quantity		Size		$a, b < 0.1$	Any number	$(a+b)/2 \leq 0.1$	Any number	$0.5 < \varnothing < 1.0$	3	Acceptable		$a \geq b$	$a/b \leq 4/3$	$a < b$	$a/b > 4/3$	Acceptable quantity		Size		$\varnothing \leq 0.4$	Any number	$0.4 < \varnothing \leq 1.0$	5	$1.0 < \varnothing \leq 1.5$	3	$1.5 < \varnothing \leq 2.0$	2
Acceptable quantity																														
Size																														
$a, b < 0.1$	Any number																													
$(a+b)/2 \leq 0.1$	Any number																													
$0.5 < \varnothing < 1.0$	3																													
Acceptable																														
$a \geq b$	$a/b \leq 4/3$																													
$a < b$	$a/b > 4/3$																													
Acceptable quantity																														
Size																														
$\varnothing \leq 0.4$	Any number																													
$0.4 < \varnothing \leq 1.0$	5																													
$1.0 < \varnothing \leq 1.5$	3																													
$1.5 < \varnothing \leq 2.0$	2																													
Minor	Colour uniformity	Level of sample for approval set as limit sample																												
Critical	Backlight	The backlight colour should correspond to the product specification																												
Critical		Flashing and or unlit backlight is not allowed																												
Minor		Dust larger than 0.25 mm is not allowed																												
Major	COB	Exposed wire bond pad is not allowed																												
Major		Insufficient covering with resin is not allowed (wire bond line exposed)																												
Minor		Dust or bubble on the resin are not allowed																												

Product No.	LMRD4165/LMRD3165	REV. B
		REV.

Page	22 / 27
------	---------

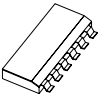
Class	Item	Criteria													
Major		No unmelted solder paste should be present on PCB													
Critical		Cold solder joints, missing solder connections, or oxidation are not allowed													
Minor		No residue or solder balls on PCB are allowed													
Critical		Short circuits on components are not allowed													
Minor	Tray particles	<table border="1"> <thead> <tr> <th></th> <th>Size</th> <th>Quantity</th> </tr> </thead> <tbody> <tr> <td rowspan="2">On tray</td> <td>$\varnothing < 0.2$</td> <td>Any number</td> </tr> <tr> <td>$\varnothing > 0.25$</td> <td>4</td> </tr> <tr> <td rowspan="2">On display</td> <td>$\varnothing \geq 0.25$</td> <td>2</td> </tr> <tr> <td>L = 3</td> <td>1</td> </tr> </tbody> </table>		Size	Quantity	On tray	$\varnothing < 0.2$	Any number	$\varnothing > 0.25$	4	On display	$\varnothing \geq 0.25$	2	L = 3	1
	Size	Quantity													
On tray	$\varnothing < 0.2$	Any number													
	$\varnothing > 0.25$	4													
On display	$\varnothing \geq 0.25$	2													
	L = 3	1													

Product No.	LMRD4165/LMRD3165	REV. B
		REV.

Page	23 / 27
------	---------

8.3 DEALING WITH CUSTOMER COMPLAINTS

8.3.1 Non-conforming analysis

Purchaser should supply Densitron with detailed data of non-conforming sample. After accepting it, Densitron should complete the analysis in two weeks from receiving the sample.

If the analysis cannot be completed on time, Densitron must inform the purchaser.

8.3.2 Handling of non-conforming displays

If any non-conforming displays are found during customer acceptance inspection which Densitron is clearly responsible for, return them to Densitron.

Both Densitron and customer should analyse the reason and discuss the handling of non-conforming displays when the reason is not clear.

Equally, both sides should discuss and come to agreement for issues pertaining to modification of Densitron quality assurance standard.

Product No.	LMRD4165/LMRD3165	REV. B
		REV.

Page	24 / 27
------	---------

9 RELIABILITY SPECIFICATION

9.1 RELIABILITY TESTS

9.1.1 Normal Temperature Range

Test Item	Test Condition	Evaluation and assessment
High Temperature Operation	50°C ±2°C for 240 hours	No abnormalities in function* and appearance
Low Temperature Operation	0°C ±2°C for 240 hours	No abnormalities in function* and appearance
Thermal Shock Storage	-20°C (30 min) ->25°C (5 min) - >70°C (30 min) - >25°C (5 min) 5 cycles	No abnormalities in function* and appearance
Vibration	10Hz ~ 55Hz 0.3mm / 1 Octave 55Hz ~ 500Hz 3g / 1 Octave 20 cycle / per axis	No abnormalities in function* and appearance

9.1.2 Wide Temperature Range

Test Item	Test Condition	Evaluation and assessment
High Temperature Operation	70°C ±2°C for 240 hours	No abnormalities in function* and appearance
Low Temperature Operation	-20°C ±2°C for 240 hours	No abnormalities in function* and appearance
Thermal Shock Storage	-30°C (30 min) ->25°C (5 min) - >80°C (30 min) - >25°C (5 min) 5 cycles	No abnormalities in function* and appearance
Vibration	10Hz ~ 55Hz 0.3mm / 1 Octave 55Hz ~ 500Hz 3g / 1 Octave 20 cycle / per axis	No abnormalities in function* and appearance

9.2 LIFE TIME

Item	Description
1	Function, performance, appearance, etc. shall be free from remarkable deterioration within 50,000 hours under ordinary operating and storage conditions of room temperature (25±10 °C), normal humidity (45±20% RH), and in area not exposed to direct sunlight.
2	Function, performance, appearance, etc. shall be free from remarkable deterioration within 5,000 hours under ordinary operating and storage conditions of 70 °C temperature, normal humidity (45±20% RH), and in area not exposed to direct sunlight.

Product No.	LMRD4165/LMRD3165	REV. B
		REV.

Page	25 / 27
------	---------

10 PART NUMBER DESCRIPTIONS FOR AVAILABLE OPTIONS

LMR①165②③240G320④⑤⑥

- ① 3 = EL backlight or no backlight option
4 = LED backlit version
- ② **POLARIZER TYPE**
B = Transflective: light background with LED backlight
A = Reflective (LMRD3165 only) No backlight
- ③ **BACKLIGHT COLOUR**
G = Green Yellow (or left blank for LMR3265)
- ④ **FLUID TYPE AND POWER SUPPLY**
D = Standard temperature range, negative supply voltage required
S = Standard temperature range, on board negative supply voltage generator
W = Wide temperature range; on-board negative supply voltage generator
H = Wide temperature range, negative supply voltage required
- ⑤ **TEMPERATURE COMPENSATION**
C = with on board temperature compensation circuitry
N = **No** on board temperature compensation and NTN Fluid
- ⑥ **Background Colour**
Y = Yellow mode
G = Grey mode

Product No.	LMRD4165/LMRD3165	REV. B
		REV.

Page	26 / 27
------	---------

10.1.1.1.1.1.1 HANDLING PRECAUTIONS

Safety

If the LCD panel breaks, be careful not to get the liquid crystal fluid in your mouth or in your eyes. If the liquid crystal touches your skin or clothes, wash it off immediately using soap and plenty of water.

Mounting and Design

Place a transparent plate (e.g. acrylic, polycarbonate or glass) on the display surface to protect the display from external pressure. Leave a small gap between the transparent plate and the display surface.

When assembling with a zebra connector, clean the surface of the pads with alcohol and keep the surrounding air very clean.

Design the system so that no input signal is given unless the power supply voltage is applied.

Caution during LCD cleaning

Lightly wipe the display surface with a soft cloth soaked with Isopropyl alcohol, Ethyl alcohol or Trichlorotrifluoroethane.

Do not wipe the display surface with dry or hard materials that will damage the polariser surface.

Do not use aromatic solvents (toluene and xylene), or ketonic solvents (ketone and acetone).

Caution against static charge

As the display uses C-MOS LSI drivers, connect any unused input terminal to VDD or VSS. Do not input any signals before power is turned on.

Also, ground your body, work/assembly table and assembly equipment to protect against static electricity.

Packaging

Displays use LCD elements, and must be treated as such. Avoid strong shock and drop from a height. To prevent displays from degradation, do not operate or store them exposed directly to sunshine or high temperature/humidity.

Caution during operation

It is indispensable to drive the display within the specified voltage limit since excessive voltage shortens its life.

Direct current causes an electrochemical reaction with remarkable deterioration of the display quality.

Give careful consideration to prevent direct current during ON/OFF timing and during operation.

Response time is extremely delayed at temperatures lower than the operating temperature range while, at high temperatures, displays become dark. However, this phenomenon is reversible and does not mean a malfunction or a display that has been permanently damaged.

If the display area is pushed on hard during operation, some graphics will be abnormally displayed but returns to a normal condition after turning off the display once.

Even a small amount of condensation on the contact pads (terminals) can cause an electro-chemical reaction which causes missing rows and columns. Give careful attention to avoid condensation.

Storage

Store the display in a dark place where the temperature is 25°C ± 10°C and the humidity below 50%RH.

Store the display in a clean environment, free from dust, organic solvents and corrosive gases.

Do not crash, shake or jolt the display (including accessories).

Product No.	LMRD4165/LMRD3165	REV. B
		REV.

Page	27 / 27
------	---------