

VARIMETER

Thermistor Motor Protection Relay MK 9003 ATEX



Your advantages

- Reliable temperature monitoring of motors
- Rapid fault location

Features

- According to pr EN 60 947-8, EN 60 079-14
- Detection of
 - overtemperature
 - broken wire in sensor circuit
 - short circuit in sensor circuit
- 1 input for 1 to 6 PTC-reistors
- Functions as options or settable with DIP-switches:
 - automatic reset (fault is not stored)
 - manual reset (fault is stored)
 - manual reset only on start-up
 - manual reset on and also after start-up
- No voltage safe manual reset
- Closed circuit operation
- LED indicators for
 - auxiliary supply
 - contact position
 - overtemperature, broken wire or short-circuit in sensor circuit
- 2 changeover contacts
- Button for reset function
- Remote reset via terminals X1 / X2 (NO contact)
- Optionally safe separation according to IEC/EN 61 140, IEC/EN 60 947-1, 6 kV/2 between:
 - auxiliary voltage and measuring circuit
 - auxiliary voltage and output contacts
 - measuring circuit and output contacts
 - the 2 changeover contacts (only with 2 changeover contacts)
- Width 22.5 mm

Circuit Diagrams

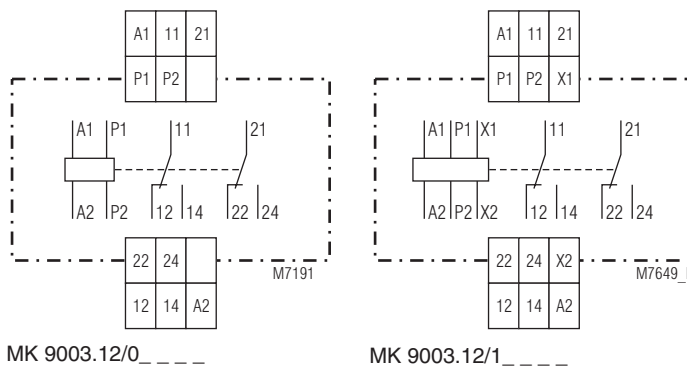

Approvals and Marking



¹⁾ Directive 94/9/EG

EG type test no.

02 ATEX 3057 II (2) G [Ex e] [Ex d] [Ex px] [Ex n]
II (2) D [Ex tb] [Ex tc]

Application

Temperature monitoring of explosion protected Motors by „extended safety“ EX e DIN EN 60079-7, „pressure proof enclosure“ EX d DIN EN 60079-1 or „overpressure enclosure“ Ex px in gas containing atmosphere as well as „protection by enclosures“ Ex t DIN EN 60079-31 in dust containing atmosphere. The thermistor Motor protection relay protects Standard and Explosion proof Motor against overheating due to overload according to DIN EN 60079-14 and DIN EN 60079-0.

Indicators

green LED:	on, when supply voltage connected
red LED:	on, when output contact de-energized
yellow LED:	on, when overtemperature of failure in sensor circuit

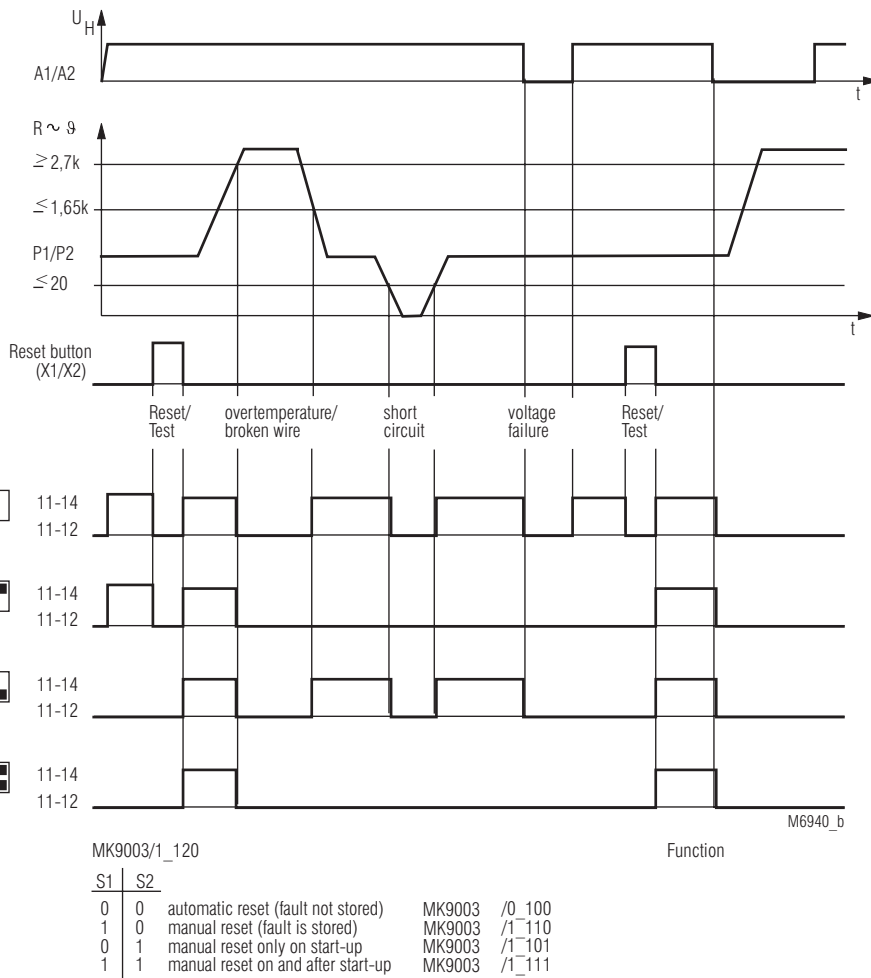

With manual reset, also after voltage failure (no start-up reset)

After the failure is gone manual reset must be made (reset button on unit or remote reset X1-X2) to bring the unit in operating mode (no voltage safe).

After voltage failure manual reset must always be made.

Activation after power on (start-up reset)

After the failure is removed the contacts switch back automatically to active condition. After voltage failure manual reset must always be made.

With manual reset (fault is stored)

After the failure is gone manual reset must be made (reset button on unit or remote reset X1-X2) to bring the unit in operating mode (no voltage safe).

Automatic reset

After the failure is removed the contacts switch back automatically to active condition.

Technical Data

Input

Response value:	2.7 ... 3.1 k Ω
Release value:	1.5 ... 1.65 k Ω
Broken wire on meas. circuit:	> 3.1 k Ω
Short circuit on meas. circuit:	< 20 Ω
Loading of measuring circuit:	< 2.5 mW (at R = 1.5 k Ω)
Voltage on measuring circuit:	\leq 2 V (at R = 1.5 k Ω)

Auxiliary Circuit

Auxiliary voltage U_H:	AC 24, 110, 230, 400 V 50 / 60 Hz DC 24 V
Voltage range:	0.85 ... 1.1 U _H
Nominal consumption	
AC:	1.5 VA, cos φ = 0.95
Nominal frequency:	50 / 60 Hz
Frequency range:	45 ... 65 Hz
Max. bridging time on voltage failure:	20 ms
Operate delay:	approx. 18 ms
Release delay:	approx. 12 ms

Remote Reset on MK 9003/1 _ _ _

Function:	remote reset X1 / X2 with voltage free NO contact
Remark:	input X1 / X2 has no galvanic separation to measuring input P1 / P2

Output

Contacts	
MK 9003.12:	2 changeover contacts
Thermal current I_{th}:	4 A
Switching capacity	
to AC 15:	
NO contact:	3 A / AC 230 V IEC/EN 60 947-5-1
NC contact:	1 A / AC 230 V IEC/EN 60 947-5-1
to DC 13:	
NO contact:	1 A / DC 24 V IEC/EN 60 947-5-1
NC contact:	1 A / DC 24 V IEC/EN 60 947-5-1
Electrical life	
to AC 15 at 5 A, AC 230 V:	1 x 10 ⁵ switching cycles IEC/EN 60 947-5-1
Short circuit strength	
max. fuse rating:	6 A gL IEC/EN 60 947-5-1
Mechanical life:	\geq 50 x 10 ⁶ switching cycles

General Data

Operating mode:	Continuous operation
Temperature range:	- 20 ... + 55°C
Storage temperature:	- 40 ... + 85°C
Clearance and creepage distances	
rated impuls voltage / pollution degree:	6 kV / 2 IEC 60 664-1
EMC	
Electrostatic discharge:	8 kV (air) IEC/EN 61000-4-2
Fast transient:	4 kV IEC/EN 61000-4-4
Interference suppression:	Limit value class B EN 55 011
Degree of protection	
Housing:	IP 40 IEC/EN 60 529
Terminals:	IP 20 IEC/EN 60 529
Housing:	Thermoplastic with V0-behaviour according to UL subject 94
Vibration resistance:	amplitude 0.35 mm frequency 10 ... 55 Hz, IEC/EN 60 068-2-6 20 / 055 / 04 IEC/EN 60 068-1
Climate resistance:	
Terminal designation:	EN 50 005
Wire connection	
max. cross section	2 x 2,5 mm ² solid or 2 x 0,75 mm ² stranded wire with sleeve DIN 46228-1/-2/-3/-4 or 2 x 1,5 mm ² strand.wire w. sl. DIN 46228-4
min. cross section:	0,5 mm ² solid or stranded wire with sleeve
Insulation of wires or sleeve length:	8 mm
Wire fixing:	Plus-Minus-terminal screws M3,5 with self-lifting clamping piece IEC/EN 60 999-1
Fixing torque:	0.8 Nm
Mounting:	DIN rail IEC/EN 60 715
Weight:	162 g

Dimensions

Width x height x depth:	22.5 x 82 x 99 mm
--------------------------------	-------------------

Technical Data

Safety Related Data

Values according to EN 61508 / EN 50495:

SIL:	1 (Type B)	
T ₁ (Proof Test Intervall):	2	a
HFT:	0	
SFF:	45,67	%
PFD _G :	9,94 x 10 ⁻³	
λ_{du} :	1135	FIT
λ_{dd} :	0	FIT
λ_{su} :	945	FIT
λ_{sd} :	0	FIT
Mode of operation:	low demand mode	
Architecture:	1001	

Values according to EN 13849:

Category:	1	
PL:	c	
MTBF:	55	a
MTTF _d :	50,5	a
DC _{avg} :	0	%



The a.m. data for functional safety is valid for an ambient temperature of 40°C respecting also selfheating. Data for other ambient temperatures are available on request.

Standard Type

MK 9003.12/11120 ATEX	AC 230 V	
Article number:	0055727	stock item
• Output:	2 changeover contacts	
• Function programmable on S1 and S2		
• With short circuit detection		
• With safe separation according to IEC/EN 61 140, IEC/EN 60 947-1		
• Auxiliary voltage U _H :	AC 230 V	
• Width:	22.5 mm	

Variants

MK 9003.12 / _ _ _ _ ATEX	
00	automatic reset
10	manual reset
01	manual reset only on start-up
11	manual reset on and also after start up
20	function programmable on S1 and S2
1	with short circuit detection
0	without safe separation
1	with safe separation (see Application example)
0	without RESET-function (only with MK 9003.__/1_100)
1	with RESET-function with MK 9003.__/1_110 MK 9003.__/1_101 MK 9003.__/1_111 MK 9003.__/1_120

available variants (others with short circuit detection on request)

MK 9003/00100 ATEX
MK 9003/01100 ATEX
MK 9003/10110 ATEX
MK 9003/11110 ATEX
MK 9003/11120 ATEX

Ordering example for variants

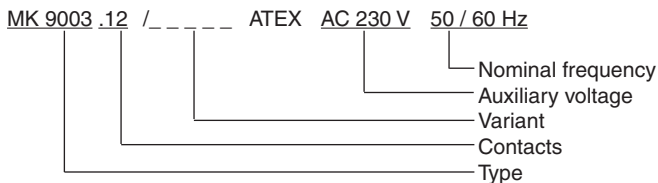

Accessories

ET 4752-143: Marking plate
Article number: 0043203

Characteristic

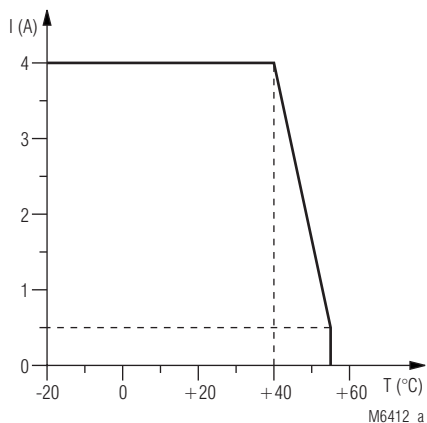

Continuous current limit curve

Application Example

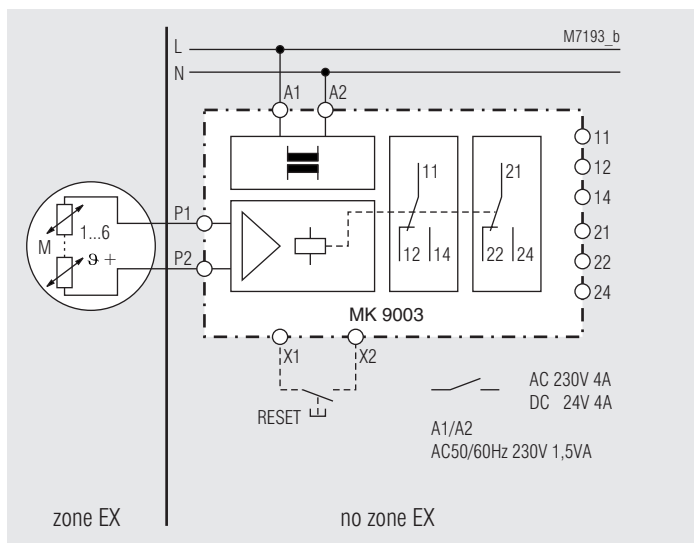

Thermistor motor protection relay shown as variant MK 9003/_1_ _ _ _ , with safe separation according to IEC/EN 61 140, IEC/EN 60 947-1, 6 kV/2 between:

- Auxiliary voltage and measuring circuit
- Auxiliary voltage and output contacts
- Measuring circuit and output contacts
- the 2 changeover contacts (only with 2 changeover contacts)

Note: See also **Installation**

Production Date

Every unit is labelled with the production date e.g. "Bj. KW 49/02". The device was produced in week 49, 2002.

Additional Information and Safety Instructions

Use on motors in explosion hazardous areas

Thermal protection on motors that are equipped with PTC sensors according to DIN 44 081 or DIN 44 082 or DIN EN 60034-11 type A (DIN EN 60947-8) .In applications with motors of the explosion protection class Ex e and Ex d only the sensor with it's connection wire leads into the Ex area. The motor protection relay has to be mounted outside the Ex-area, but monitors devices operated in the Ex-area.

Safety integrity level SIL 1

To fulfil SIL 1 a cyclic function test of the protection device has to be provided. This can be done manually during maintenance (see below).

The function test must be carried out all 2 years.

Test facilities for set-up and maintenance

A test of the unit can be made by simulating the resistance on the sensor input. During maintenance these tests can also be made.

- Test of short circuit detection: Bridge sensor input (this test is possible without disconnection of the sensor).
- Test of broken wire detection: Disconnect sensor wire.
- Test of overtemperature function: Change resistance on input from low 50 ... 1500 Ω to 4 kΩ.

The RESET button can also be used for test purpose (see Function Diagram)

Installation

The DC 24 V version has no galvanic separation between auxiliary supply (A1, A2) and the sensor circuit (P₁, P₂). These units are only allowed to be connected to transformers according to DIN EN 61 558 or to battery supply.

Wiring

The sensor and control wires have to be installed separately from the motor wires. When strong inductive or capacitive influence is expected from parallel installed high current wires, screened wire should be used.

Wire length

The max. wire length of the sensor circuit is:

Diameter (mm ²):	4	2.5	1.5	0.5
max. wire length (m):	2 x 550	2 x 250	2 x 150	2 x 50

Safety instructions

- Installation, test and replacement may only be carried out by qualified specialist staff and the applicable safety rules must be observed. The data for functional safety in explosion hazardous areas have to be respected.
- Details of the motor supplier and the details about the explosion protection from the EC-type examination certificates for explosion proof motors have to be respected.
- For the test and the maintenance of motor protection devices for explosion proof machines, the EN 60079-17 and the safety rules that result from the motor application and the corresponding type of protection have to be respected (EC ATEX Directive 94/9/EC and DIN EN 60079-14).
- The motor protection relay has to switch off the motor immediately also when it is controlled by an inverter. The control circuit must allow this. In this case the sensor wires must be lead separately. The use of wires inside the motor connection cable is not allowed.
- If variants are used that have no no-voltage safe reset function additional measures have to be applied in order to disable safely the restart of the motor until the fault is removed if this leads to a dangerous situation.
- The relay must only be opened by the manufacturer.
- The relay must only be replaced by equivalent devices marked according to the relevant safety rules.
- The permitted ambient conditions must be observed.
- Devices that show obvious transportation damage must not be used in safety relevant applications.