

Insulated Enclosure KO 4717

with box terminals
for machine soldering or plug-in technology

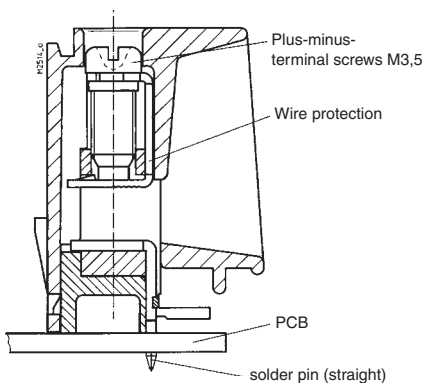

- Width 100 mm
- Max. 30 box terminals with captive plus-minus-screws
- Electrical connection of PCB to terminal in machine soldering or plug-in technology
- Mounting of SMD components possible on soldering side
- Optionally with changeable plate
- Spacer for PCB coding
- Optionally with removable terminal strip for plug-in technology
- Optionally with Blanking strip



Box terminal for machine soldering

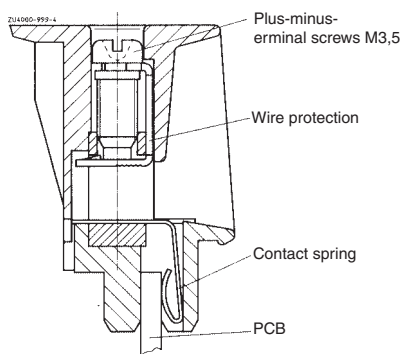

Box terminal for plug-in technology

Technical Data

Order references: Front colour	beige	light grey RAL 7035	blue RAL 5015	Enclosure variant with
KO 4717.118.30.03	.001	.004	.007	front plate solder pin bended
KO 4717.118.30.03	.002	.005	.008	plate solder pin bended
KO 4717.118.30.03	.003	.006	.009	plate clear solder pin bended
KO 4717.118.30.03	.019	.022	.025	front plate soldering lug
KO 4717.118.30.03	.020	.023	.026	plate soldering lug
KO 4717.118.30.03	.021	.024	.027	plate clear soldering lug
KO 4717.118.30.02	.001	.004	.007	front plate plug-in techn
KO 4717.118.30.02	.002	.005	.008	plate plug-in technology
KO 4717.118.30.02	.003	.006	.009	plate clear plug-in techn.

Outer dimensions: 100 x 73.2 x 118.2 mm
Enclosure material: PC-GF, base black, front colour see table

Temperature stability:	
complying with UL 746 B:	125 °C
complying with Vicat	
ISO 306 Meth. B:	148 °C
compl.with ISO 75-2 Meth. A:	138 °C
	Meth. B: 144 °C

Max. permitted power dissipation: 29 W for stand alone enclosure at normal climate 23/50-1 ISO 554

Specific thermal resistance: $R_{th} = 3 \text{ K / W}$ for stand alone enclosure

Flame retardancy: V-0; Plate clear = V-2
 complying withh UL 94: BH 2-30
 complying with IEC 60 707:

Number of terminals: 30, < 30 on request

Terminal material
solder technology: CuSn tin-plated
plug-in technology: CuBe tin-plated
Max. cross section for connection: each 1 x 4 mm² solid
 each 1 x 2.5 mm² stranded ferruled DIN 46 228-1/-2/-3/-4
 each 2 x 1.5 mm² stranded ferruled DIN 46 228-1/-2/-3/-4
 10 mm

Insulation of wires length:
Max. cross resistance to printed circuit board: 10 mΩ $\hat{=}$ 1 W / terminal (power dissipation)

Max. current carrying capacity
machine soldering: 16 A
plug-in technology: 10 A

Wire fastening
soldering and plug-in technology: captive plus-minus terminal screws M3.5
 box-terminals with self-raising wire protection
 terminal strip removable separately

plug-in technology:
Torque: max. 0.8 Nm

Connection inside: machine solderable solder pins
plug-in technology: direct plug-in on PCB

Enclosure fastener:
 1) Snap-on fastener on top hat rail EN 50 022
 2) screw fixing with retractable clips, fastening dimensions 80 mm for 2 screws M4

Creepage current resistance: CTI 175 $\hat{=}$ insulating material III a IEC 60 664-1
Air gap and creepage distance: $\geq 3.3 \text{ mm}$ IEC 60 664-1

Type of protection: Enclosure IP 40 IEC 60 529
 Terminals IP 20 IEC 60 529
 contact protection complies with VBG 4

Print area: 100 x 42 mm (on front plate)

Printed circuit board: see printed circuit design

Printed circuit board holder: Guide ribs on the small side and on the enclosure bottom for 5 PCBs

Net-weight: 250 g
Accessories: clips for screw fixing

		plug-in technology			solder techn. clear
		clear	beige	grey	
Spacer for PCB coding	KO 4721-8-1				
Blanking plug	KO 4721-7-	1.22			1.24
Blanking strip	KO 4718-		26.2	26.3	26.4

Machine soldering

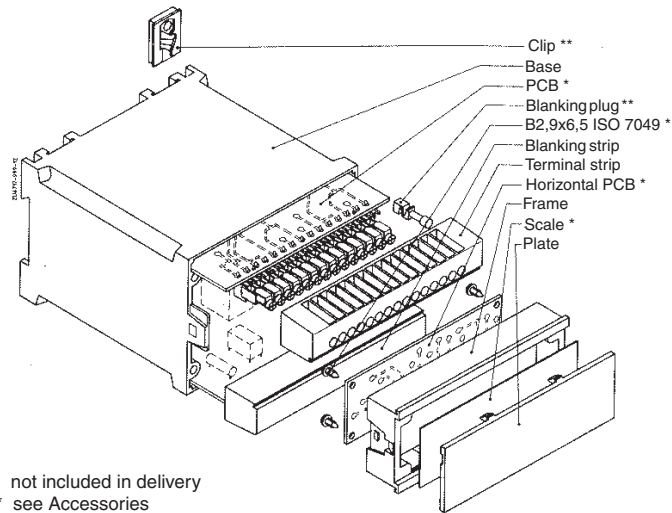

Dimensions

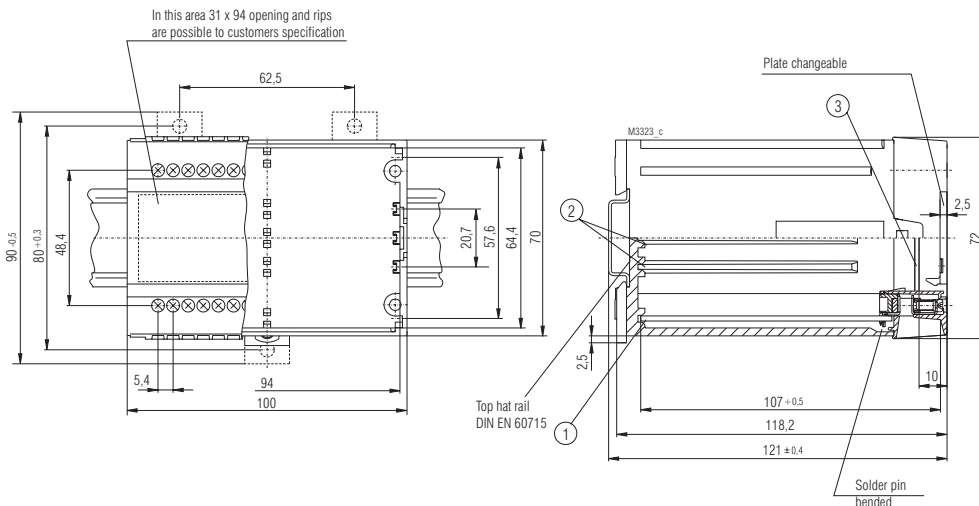

Printed circuit board designs

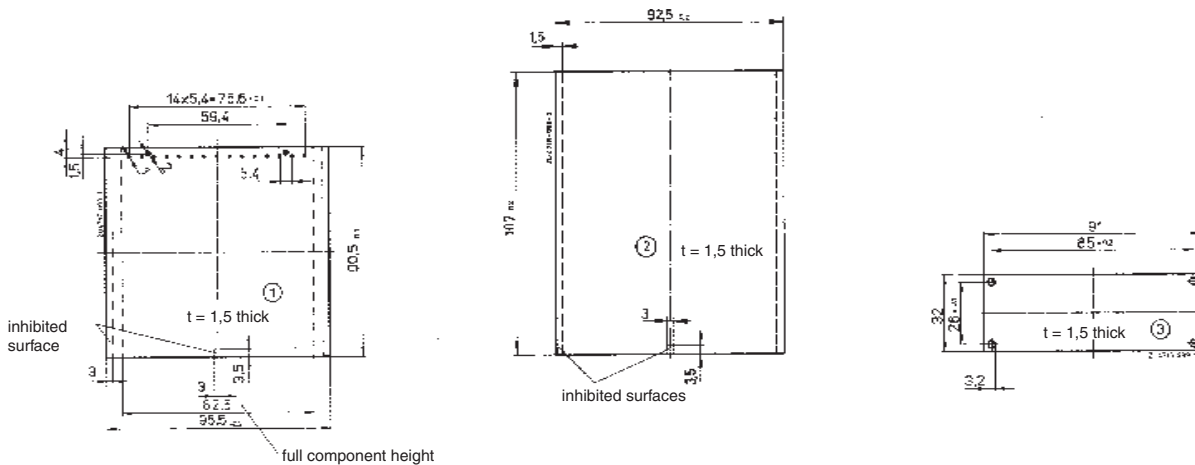

Plug-in technology

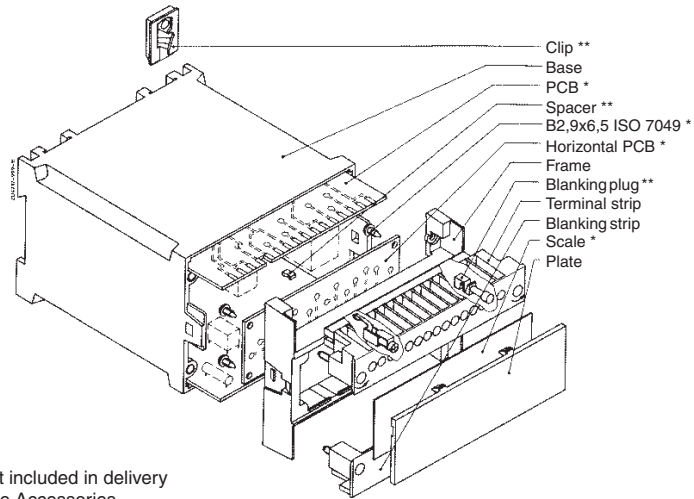

Dimensions

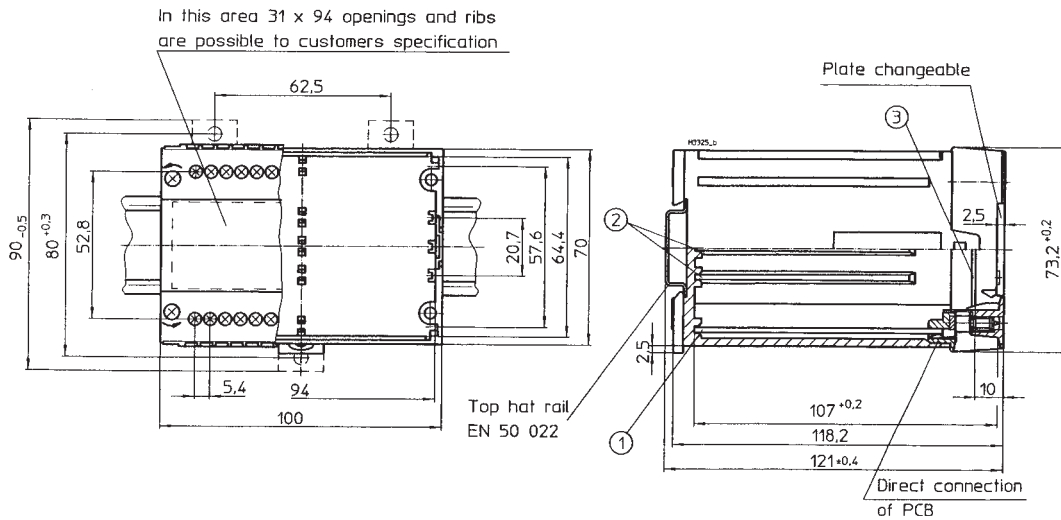

Printed circuit board designs

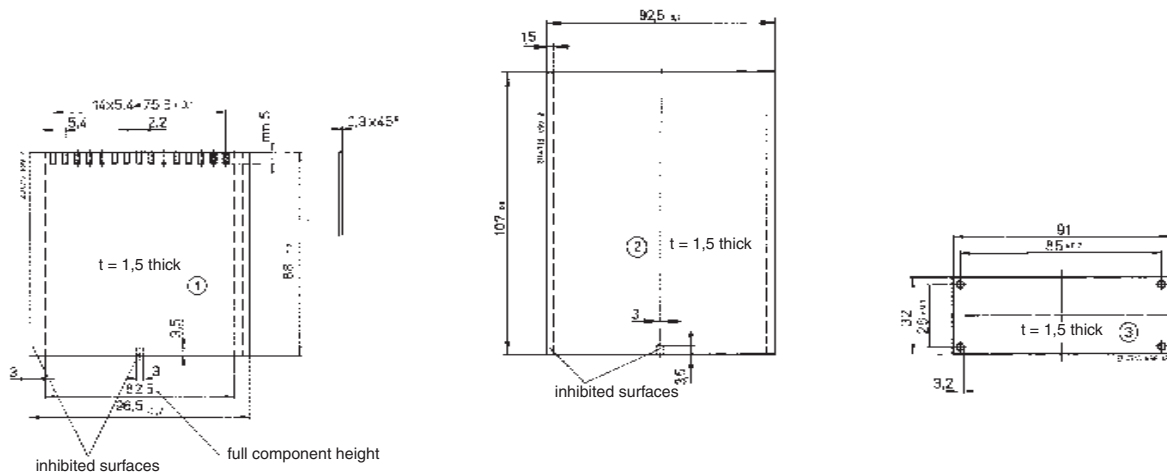

Notes on Housing Opening

Enclosure for solder technology

1. Tool
 - for all functions use 0,8 x 4,0 or 0,8 x 4,5 screwdriver
2. Removing of frame
 - Insert a screwdriver in the side recesses of the base (underneath)
 - With light pressure, turn the screwdriver to the left or right.
 - The snap-in lug of the frame disengages.
 - Repeat disengaging process on opposite side. The frame can be removed.

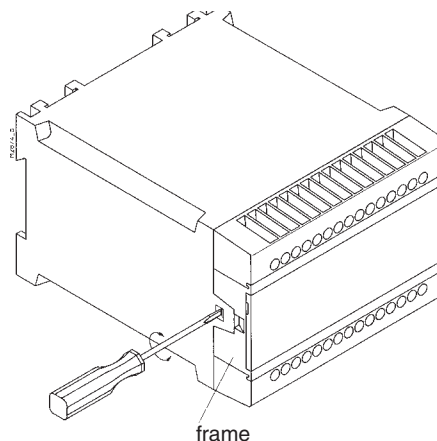

Enclosure for plug-in technology

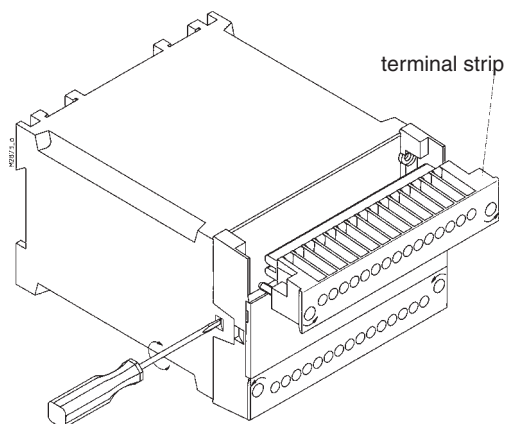
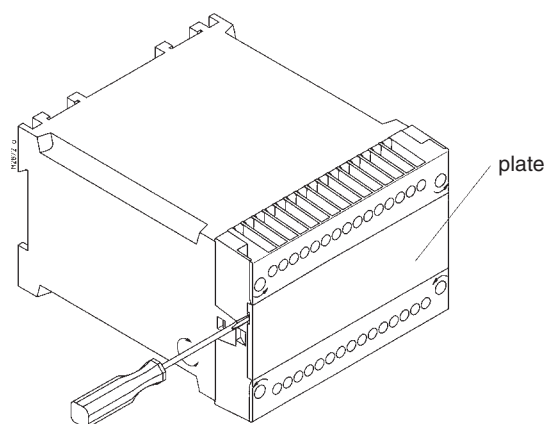

To remove the front plate first unscrew the terminal strips fixing screws and lift off the terminal strips.

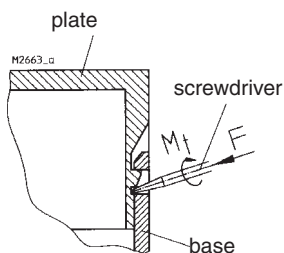

To remove front-frame insert an 0,8 x 4,0 or 0,8 x 4,5 screwdriver into the side recess, on the hood, and turn lightly to the left or right until the snap-in lug disengages. Repeat in the opposite side.