

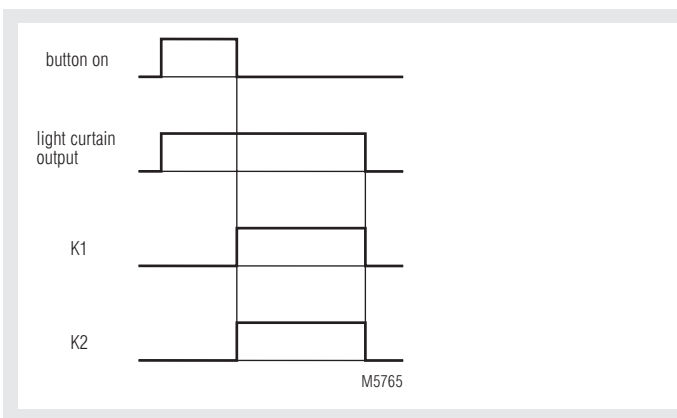

LG 5925/920

- According to
 - Performance Level (PL) e and category 4 to EN ISO 13849-1: 2008
 - SIL Claimed Level (SIL CL) 3 to IEC/EN 62061
 - Safety Integrity Level (SIL) 3 to IEC/EN 61508
- to connect:
 - safety switch NE 5020
 - safety switch NE 5021
- Output: max. 4 NO contacts, see contacts
- 1- or 2-channel operation
- Line fault detection on On-button
- Manual restart or automatic restart, switch S2
- with or without cross fault monitoring switch S1
- LED indicator for state of operation
- LED indicator for channel 1 and 2
- Wire connection: also 2 x 1.5 mm² stranded ferruled, or 2 x 2.5 mm² solid DIN 46 228-1/-2/-3/-4
- As option with pluggable terminal blocks for easy exchange of devices
 - with screw terminals
 - or with cage clamp terminals
- Width 22.5 mm

Function Diagram



Approvals and Marking



Applications

- Protection of people and machines
- Monitoring of safety gates

Indicators

- upper LED: on, when supply connected
lower LEDs: on, when relay K1 and K2 energized

Notes

Line fault detection on On-button:
The line fault detection is only active when S12 and S22 are switched simultaneously. If The On-button is closed before S12, S22 is connected to voltage (also when line fault across On-Button), the output contacts will not close. A line fault across the On-button which occurred after activation of the relay, will be detected with the next activation and the output contacts will not close.

ATTENTION ! If a line fault occurs after the voltage has been connected to S12, S22, the unit will be activated because this line fault is similar to the normal On-function.

Block Diagram

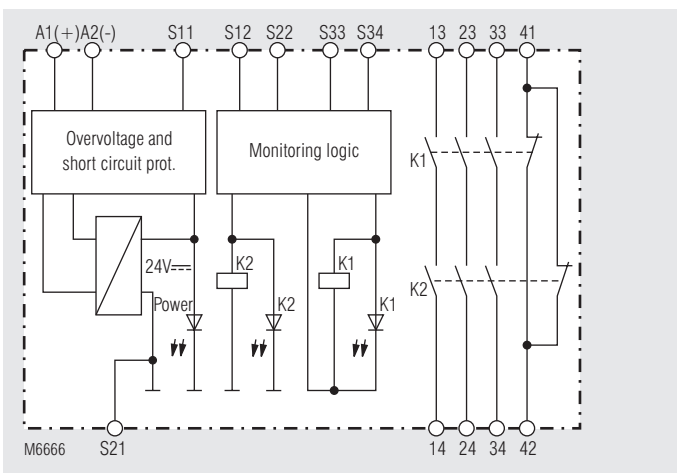

Circuit Diagrams

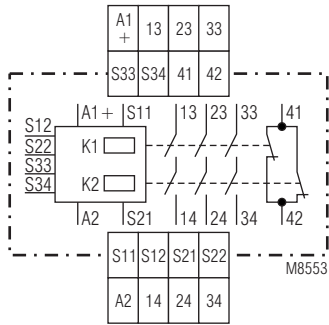

LG 5925.48/920

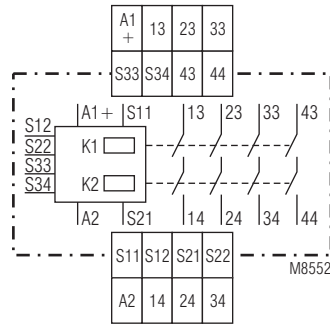

LG 5925.04/920

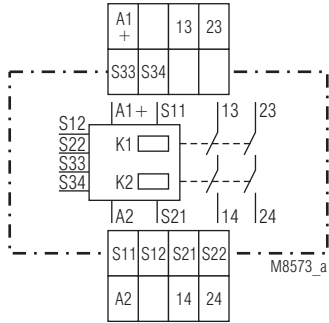

LG 5925.02/920

Connection Terminals

Terminal designation	Signal designation
A1 (+)	+ / L
A2 (-)	- / N
S12, S22, S34	Inputs
S11, S21, S33	Outputs
13, 14, 23, 24, 33, 34, 43, 44	Forcibly guided NO contacts for release circuit
41,42	Forcibly guided indicator output

Unit Programming

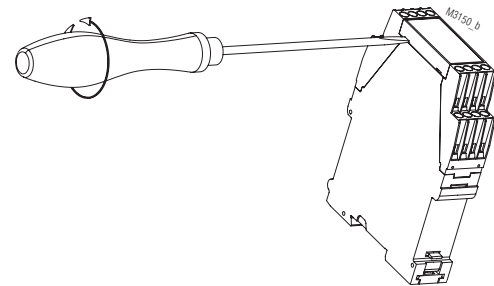
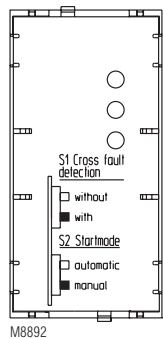

Disconnect unit before setting of S1
Drawing shows setting at the state of delivery

M8892

Technical Data

Input

Nominal voltage U_N:	DC 24 V
Voltage range:	0.9 ... 1.1 U_N
Nominal consumption:	DC approx. 1.7 W
Min. Off-time:	250 ms
Control voltage on S11 at U_N:	DC 22.5 V
Control current (typ.) over S12 or S22:	35 mA at U_N
Min. voltage between terminals S12, S22 when relay activated:	DC 19 V
Short-circuit protection:	Internal PTC
Oversvoltage protection:	Internal VDR

Output

Contacts

LG 5925.02/920:	2 NO contacts
LG 5925.04/920:	4 NO contacts
LG 5925.48/920:	3 NO contacts, 1 NC contact

The NO contacts are safety contacts.

ATTENTION! The NC contacts 41-42 can only be used for monitoring

Operate delay typ. at U_N :

Manual start:	20 ms
Automatic start:	350 ms

Release delay typ. at U_N :

Disconnecting the supply:	20 ms
Disconnecting S12, S22:	15 ms

Contact type: forcibly guided

Nominal output voltage: AC 250 V

DC: see limit curve for arc-free operation
max. 8 A per contact
see current limit curve

Thermal current I_{th} :

Switching capacity

to AC 15:		
NO contacts:	3 A / AC 230 V	IEC/EN 60 947-5-1
NC contacts:	2 A / AC 230 V	IEC/EN 60 947-5-1
to DC 13:		
NO contacts:	2 A / DC 24 V	IEC/EN 60 947-5-1
NC contacts:	2 A / DC 24 V	IEC/EN 60 947-5-1

Electrical life

at 5 A, AC 230 V $\cos \varphi = 1$: > 2.2 x 10⁶ switching cycles

Permissible operating frequency:

max. 1 200 switching cycles / h

Short circuit strength

max. fuse rating: 10 A gL IEC/EN 60 947-5-1
line circuit breaker: B 6 A

Mechanical life:

> 20 x 10⁶ switching cycles

General Data

Operating mode: Continuous operation

Temperature range

operation: - 15 ... + 55 °C
storage: - 40 ... + 85 °C

altitude:

< 2.000 m

Clearance and creepage distances

rated impuls voltage / pollution degree: 4 kV / 2 (basis insulation) IEC 60 664-1

EMC

Electrostatic discharge:	8 kV (air)	IEC/EN 61 000-4-2
HF-irradiation:	10 V / m	IEC/EN 61 000-4-3
Fast transients:	2 kV	IEC/EN 61 000-4-4

Surge voltages

between wires for power supply:	0.5 kV	IEC/EN 61 000-4-5
between wire and ground:	2 kV	IEC/EN 61 000-4-5
Interference suppression:	Limit value class B	EN 55 011

Degree of protection

Housing:	IP 40	IEC/EN 60 529
Terminals:	IP 20	IEC/EN 60 529

Housing:

Thermoplastic with V0 behaviour according to UL subject 94

Vibration resistance:

Amplitude 0.35 mm IEC/EN 60 068-2-6
frequency 10 ... 55 Hz

Climate resistance:

15 / 055 / 04 IEC/EN 60 068-1

Technical Data

Terminal designation:	EN 50 005
Wire connection	DIN 46 228-1/-2/-3/-4
Screw terminals (integrated):	1 x 4 mm ² solid or 1 x 2.5 mm ² stranded ferruled or 2 x 1.5 mm ² stranded ferruled or 2 x 2.5 mm ² solid
Insulation of wires or sleeve length:	8 mm
Plugin with screw terminals	
max. cross section for connection:	1 x 2.5 mm ² solid or 1 x 2.5 mm ² stranded ferruled
Insulation of wires or sleeve length:	8 mm
Plugin with cage clamp terminals	
max. cross section for connection:	1 x 4 mm ² solid or 1 x 2.5 mm ² stranded ferruled
min. cross section for connection:	0.5 mm ²
Insulation of wires or sleeve length:	12 ±0.5 mm
Wire fixing:	Plus-minus terminal screws M 3.5 box terminals with wire protection or cage clamp terminals
Mounting:	DIN rail IEC/EN 60 715
Weight:	220 g

Dimensions

Width x height x depth

LG 5925/920:	22.5 x 90 x 121 mm
LG 5925/920 PC:	22.5 x 111 x 121 mm
LG 5925/920 PS:	22.5 x 104 x 121 mm

Safety Related Data

Values according to EN ISO 13849-1:

Category:	4	
PL:	e	
MTTF _d :	176.2	a (year)
DC _{avg} :	99.0	%
d _{op} :	365	d/a (days/year)
h _{op} :	24	h/d (hours/day)
t _{Zyklus} :	3600	s/Zyklus
	≅ 1	/h (hour)

Values according to IEC EN 62061 / IEC EN 61508:

SIL CL:	3	IEC EN 62061
SIL:	3	IEC EN 61508
HFT ¹⁾ :	1	
DC _{avg} :	99.0	%
SFF:	99.7	%
PFH _D :	2.66E-10	h ⁻¹
T _r :	20	a (year)

¹⁾ HFT = Hardware-Failure Tolerance



The values stated above are valid for the standard type. Safety data for other variants are available on request. The safety relevant data of the complete system has to be determined by the manufacturer of the system.

Standard Type

LG 5925.48/920 DC 24 V	
Article number:	0063683
• Output:	3 Schließer, 1 Öffner
• Nominal voltage U _N :	DC 24 V
• Width:	22.5 mm

Ordering Example

LG 5925 . . . /920 DC 24 V

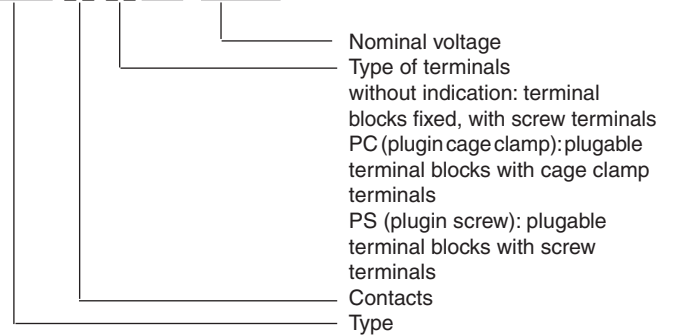

Options with Pluggable Terminal Blocks

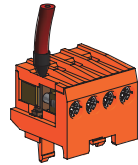

Screw terminal
(PS/plugin screw)

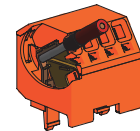

Cage clamp terminal
(PC/plugin cage clamp)

Notes

Removing the terminal blocks with cage clamp terminals

1. The unit has to be disconnected.
2. Insert a screwdriver in the side recess of the front plate.
3. Turn the screwdriver to the right and left.
4. Please note that the terminal blocks have to be mounted on the belonging plug in terminations.

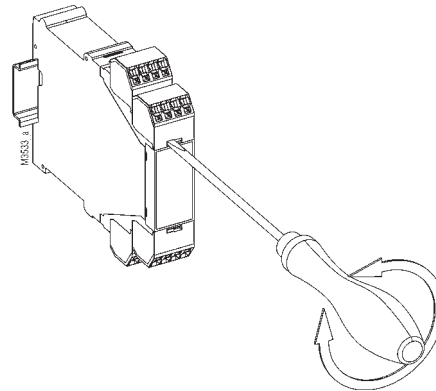

Characteristics

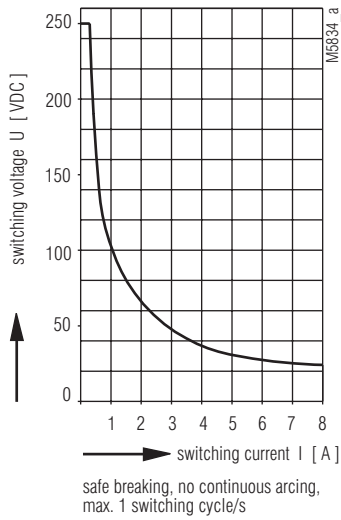

Arc limit curve under resistive load

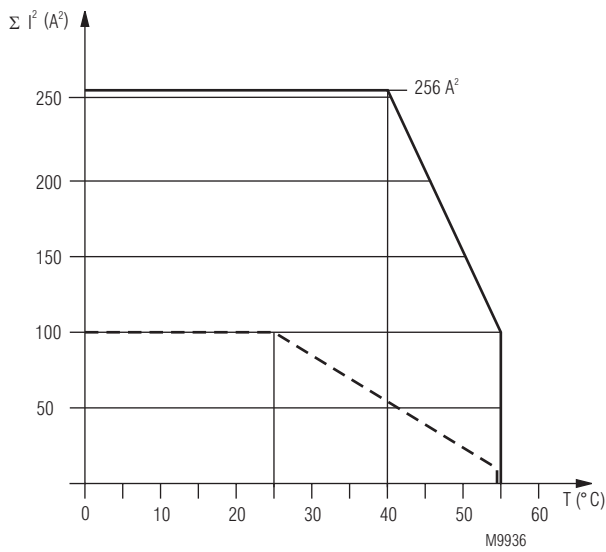

— device mounted on distance with air circulation.
max. current at 55°C over
4 contactrows = $5A \cong 4 \times 5^2 A^2 = 100A^2$

- - - device mounted without distance heated by
devices with same load,
max current at 55°C over
4 contactrows = $1A \cong 4 \times 1^2 A^2 = 4A^2$

$$\Sigma I^2 = I_1^2 + I_2^2 + I_3^2 + I_4^2$$

I_1, I_2, I_3, I_4 - current in contactrows

Quadratic total current limit curve

Accessories

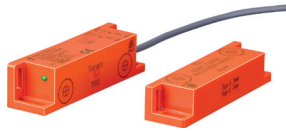

NE 5020.92
safety switch, magnetic coded,
for DC 24 V, with 2 semiconductor
outputs



NE 5021.02
safety switch, magnetic coded, with
2 NO contacts (reed contacts)

Application Examples

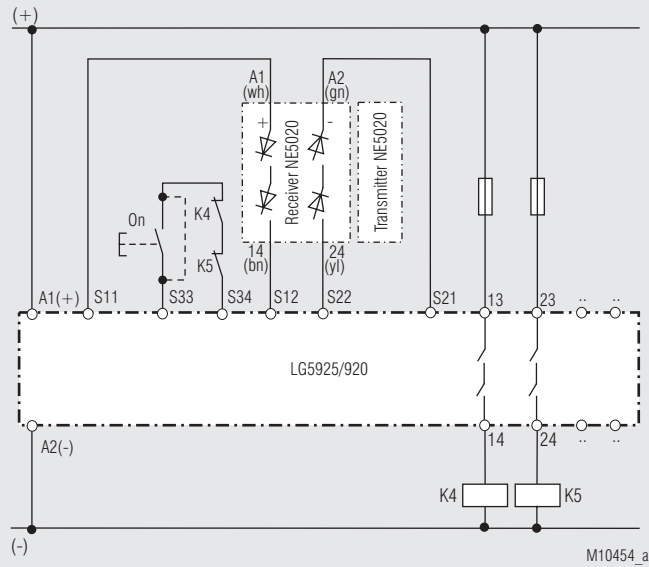

With safety switch NE 5020. Contact reinforcement by external contactors. 2-channel operation, cross fault detection

Please note: Refer to „Unit programming“!

Switches in position: S1 cross fault detection
S2 manual start

With autostart link On-button and set S2 to „automatic“.
Suited up to SIL3, Performance Level e, Cat. 4

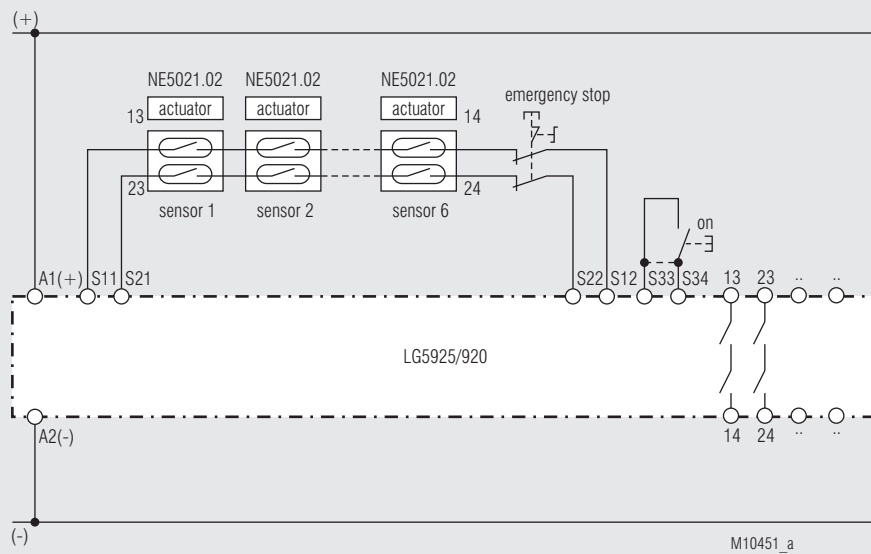

6 safety switches NE 5021 + 1 E-stop button in series. 2-channel operation, cross fault detection

Please note: Refer to „Unit programming“!

Switches in position: S1 cross fault detection
S2 manual start

With autostart link On-button and set S2 to „automatic“.
Suited up to SIL3, Performance Level e, Cat. 3

