

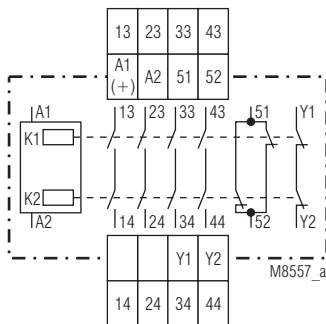

- According to
 - Performance Level (PL) e and category 4 to EN ISO 13849-1: 2008
 - SIL Claimed Level (SIL CL) 3 to IEC/EN 62061
 - Safety Integrity Level (SIL) 3 to IEC/EN 61508
- when connected to a suitable safety module
- Control from semiconductor safety outputs (light curtains, e-stop, etc.) is also possible
- Redundant and forcibly guided contacts
- Output: max. 5 NO contacts or 4 NO contacts / 1 NC contact
- 1-channel or 2-channel connection
- LED indication for operation
- Removeable terminal strips
- Wire connection: also 2 x 1.5 mm² stranded ferruled, or 2 x 2.5 mm² solid DIN 46 228-1/-2/-3/-4
- As option with pluggable terminal blocks for easy exchange of devices
 - with screw terminals
 - or with cage clamp terminals
- Width 22.5 mm

Circuit Diagrams



LG 5929.54

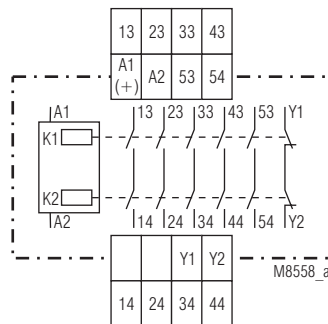

LG 5929.60

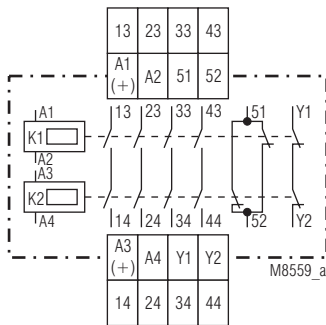

LG 5929.54/100

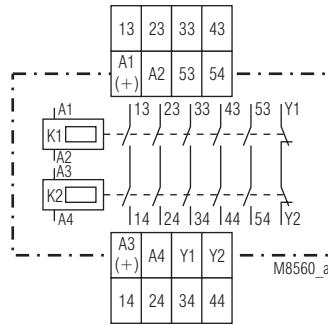

LG 5929.60/100

Connection Terminals

Terminal designation	Signal designation
A1 (+), A3 (+)	+ / L
A2 (-), A4 (-)	- / N
13, 14, 23, 24, 33, 34, 43, 44, 53, 54	Forcibly guided NO contacts for release circuit
51, 52	Forcibly guided indicator output
Y1, Y2	Forcibly guided feedback circuit

Approvals and Marking



Applications

Contact multiplication of emergency-stop modules and safety door monitors.

Indication

- LG 5929
LED K1/K2: on, when operating voltage applied
- LG 5929/100
LED K1: on, when relay K1 energized
LED K2: on, when relay K2 energized

Notes

The extension module LG 5929 must only be used together with a safety unit e.g. LG 5925) that monitors the feedback circuit Y1/Y2 to achieve (SIL CL) 3 acc. to IEC/EN 62061, SIL 3 to IEC/EN 61508, Performance Level (PL) e and Category 4 to EN ISO 13849-1: 2008.

Block Diagram

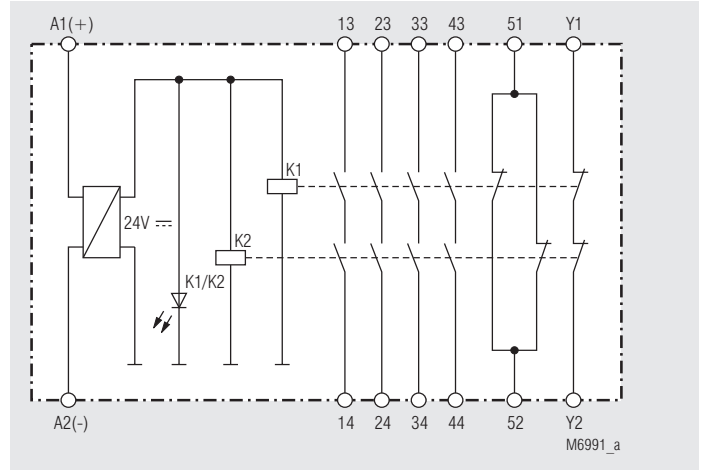

LG 5929.54

Block Diagrams

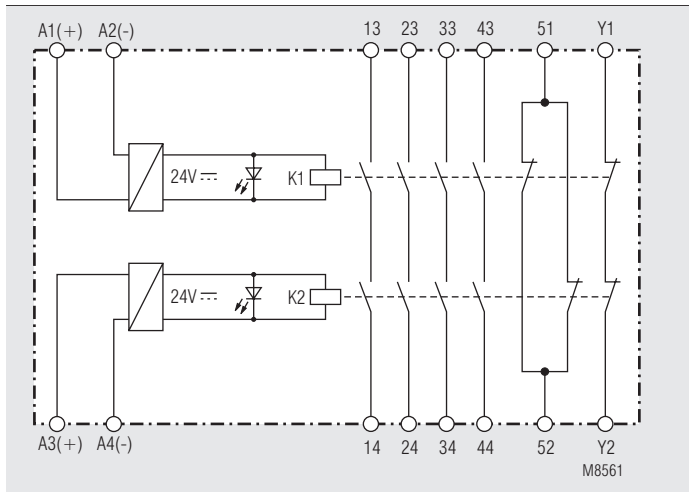

LG 5929.54/100

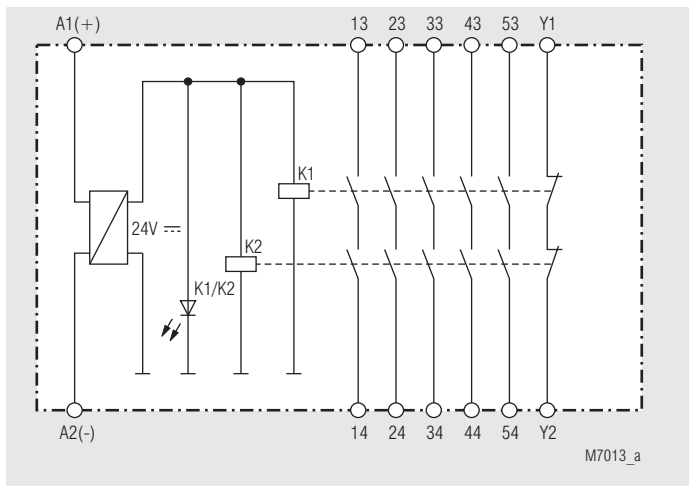

LG 5929.60

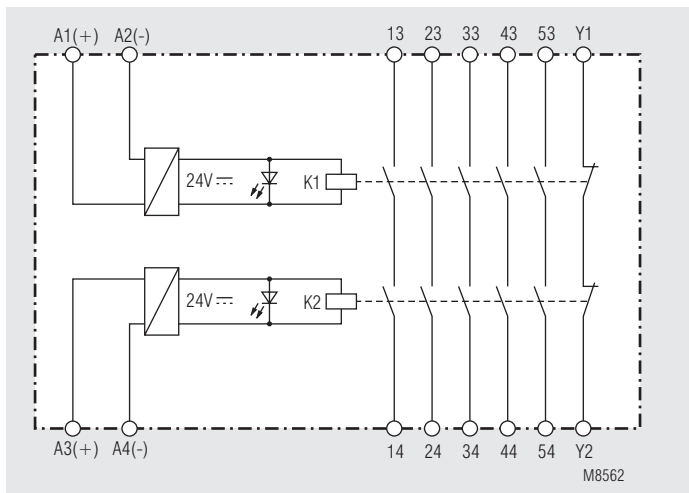

LG 5929.60/100

Technical Data

Input

Nominal voltage U_N:	AC / DC 24 V, AC / DC 110 / 115 V, AC 110 / 115 V, AC 230 / 240 V
Voltage range:	AC 0.85 ... 1.1 U_N DC 0.9 ... 1.1 U_N DC 0.85 ... 1.1 U_N
Nominal consumption at U_N	AC / DC 24 V: 1.8 VA AC / DC 110/115 V: 2.0 VA AC 110/115 V, 230/240 V: 3.0 VA
Nominal frequency:	50 / 60 Hz
Control current:	at 24 V over 2 relays: 75 mA

Output

Contacts	LG 5929.60, LG 5929.60/100: 5 NO contacts, 1 NC contact for feed back circuit
	LG 5929.54, LG 5929.54/100: 4 NO contacts, 1 NC contact 1 NC contact for feed back circuit
Operate time:	max. 20 ms
Release time:	max. 35 ms
Contact type:	forcibly guided
Nominal output voltage:	AC 250 V
Thermal current I_{th}:	see total current limit curve max. 5 A

Switching capacity		
to AC 15:		
NO contact:	3 A / AC 230 V	IEC/EN 60 947-5-1
NC contact:	2 A / AC 230 V	IEC/EN 60 947-5-1
to DC 13:		
NO contact:	2 A / DC 24 V	IEC/EN 60 947-5-1
NC contact:	2 A / DC 24 V	IEC/EN 60 947-5-1
to DC 13:		
NO contact:	4 A / 24 V at 0.1 Hz	IEC/EN 60 947-5-1
NC contact:	4 A / 24 V at 0.1 Hz	IEC/EN 60 947-5-1
Electrical life		
to AC 15 at 2 A, AC 230 V:	10 ⁵ switching cycles	IEC/EN 60 947-5-1
Permissible switching capacity:	1200 switching cycles / h	
Short circuit strength		
max. fuse rating:	10 A gL	IEC/EN 60 947-5-1
max. line circuit breaker:	B 6 A	
Mechanical life:	20 x 10 ⁶ switching cycles	

General Data

Operating mode:	Continuous operation
Temperature range	
operation:	- 15 ... + 55 °C
storage :	- 25 ... + 85 °C
altitude:	< 2.000 m
Clearance and creepage distances	
rated impuls voltage / pollution degree:	4 kV / 2 (basis insulation) IEC 60 664-1
EMC	
Electrostatic discharge:	8 kV (air) IEC/EN 61 000-4-2
HF-irradiation:	10 V / m IEC/EN 61 000-4-3
HF-wire guided:	10 V IEC/EN 61 000-4-6
Fast transients:	4 kV IEC/EN 61 000-4-4
Surge voltages	
between wires for power supply:	1 kV IEC/EN 61 000-4-5 0.5 kV IEC/EN 61 000-4-5 at AC/DC 24 V
between wire and ground:	4 kV IEC/EN 61 000-4-5
Interference suppression:	Limit value class B EN 55 011
Degree of protection	
Housing:	IP 40 IEC/EN 60 529
Terminals:	IP 20 IEC/EN 60 529
Housing:	Thermoplast with V0 behaviour according to UL subject 94
Vibration resistance:	Amplitude 0.35 mm IEC/EN 60 068-2-6 frequency 10 ... 55 Hz
Climate resistance:	15 / 055 / 04 IEC/EN 60 068-1
Terminal designation:	EN 50 005
Wire connection	DIN 46 228-1/-2/-3/-4
Screw terminals (integrated):	1 x 4 mm ² solid or 1 x 2.5 mm ² stranded ferruled (isolated) or 2 x 1.5 mm ² stranded ferruled (isolated) or 2 x 2.5 mm ² solid

Technical Data

Insulation of wires or sleeve length:	8 mm
Plug in with screw terminals max. cross section for connection:	1 x 2.5 mm ² solid or 1 x 2.5 mm ² stranded ferruled (isolated)
Insulation of wires or sleeve length:	8 mm
Plug in with cage clamp terminals max. cross section for connection:	1 x 4 mm ² solid or 1 x 2.5 mm ² stranded ferruled
min. cross section for connection:	0.5 mm ²
Insulation of wires or sleeve length:	12 ±0.5 mm
Wire fixing:	Plus-minus terminal screws M 3.5 box terminals with wire protection or cage clamp terminals
Mounting:	DIN rail
Weight:	205 g
	IEC/EN 60 715

Dimensions

Width x height x depth

LG 5929:	22.5 x 90 x 121 mm
LG 5929 PC:	22.5 x 111 x 121 mm
LG 5929 PS:	22.5 x 104 x 121 mm

Safety Related Data

Values according to EN ISO 13849-1:

Category:	4	
PL:	e	
MTTF _d :	144,3	a (year)
DC _{avg} :	99.0	%
d _{op} :	365	d/a (days/year)
h _{op} :	24	h/d (hours/day)
t _{cycle} :	3.60E+03	s/cycle
	± 1	/h (hour)

Values according to IEC/EN 62061 / IEC/EN 61508:

SIL CL:	3	IEC/EN 62061
SIL	3	IEC/EN 61508
HFT ¹⁾ :	1	
DC _{avg} :	99.0	%
SFF	99.7	%
PFH _d :	3.27E-10	h ⁻¹
T _i :	20	a (year)

¹⁾ HFT = Hardware-Failure Tolerance



The values stated above are valid for the standard type. Safety data for other variants are available on request.

The safety relevant data of the complete system has to be determined by the manufacturer of the system.

UL-Data

The safety functions were not evaluated by UL. Listing is accomplished according to requirements of Standard UL 508, "general use applications"

Switching capacity:

Ambient temperature 45°C:	Pilot duty B300 5A 250Vac Resistive 5A 24Vdc Resistive or G.P.
Ambient temperature 55°C:	Pilot duty B300 4A 250Vac Resistive 4A 24Vdc Resistive or G.P.c

Wire connection:

Screw terminals fixed:	60°C / 75°C copper conductors only
Plug in screw:	AWG 20 - 12 Sol/Str Torque 0.8 Nm
	AWG 20 - 14 Sol Torque 0.8 Nm
	AWG 20 - 16 Str Torque 0.8 Nm
Plug in cage clamp:	AWG 20 - 12 Sol/Str



Technical data that is not stated in the UL-Data, can be found in the technical data section.

Standard type

LG 5929.60/61	AC/DC 24 V	50/60 Hz
Article number:	0064092	
• Output:	5 NO contacts, 1 NC contact for feed back circuit	
• Nominal voltage U _N :	AC/DC 24 V	
• Width:	22.5 mm	

Variant

LG 5929._._/100: for 2-channel connection, with 2 LEDs

Ordering example for variant

LG 5929._._/100 /61 AC/DC 24 V 50/60 Hz

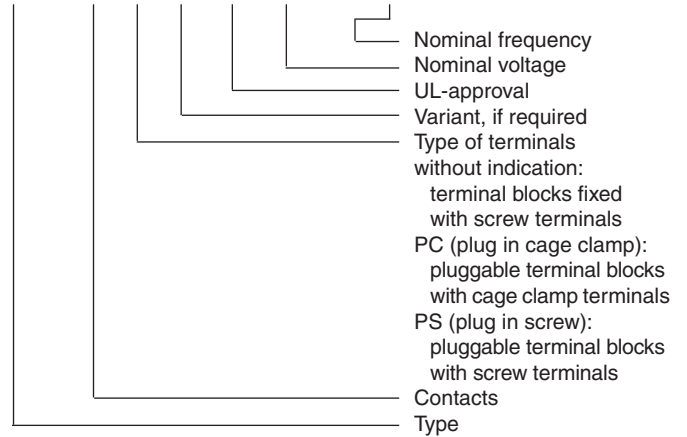

Options with Pluggable Terminal Blocks

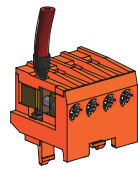

Screw terminal
(PS/plugin screw)

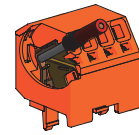

Cage clamp terminal
(PC/plugin cage clamp)

Notes

Removing the terminal blocks with cage clamp terminals

1. The unit has to be disconnected.
2. Insert a screwdriver in the side recess of the front plate.
3. Turn the screwdriver to the right and left.
4. Please note that the terminal blocks have to be mounted on the belonging plug in terminations.

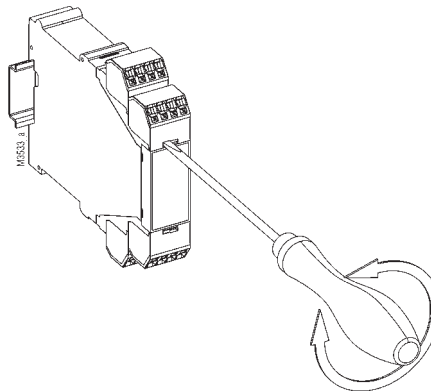

Characteristics

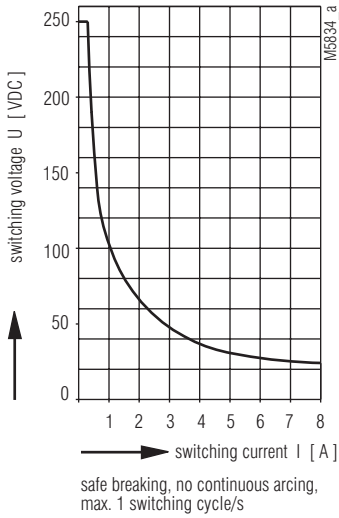

Arc limit curve under resistive load

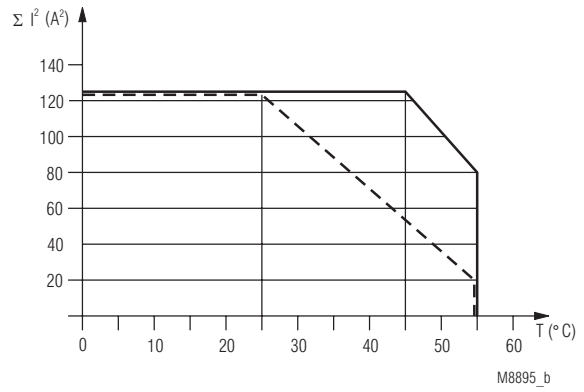

- AC / DC 24 V AC 230V device mounted on distance with aircondition
- - - AC / DC 24 V AC 230V device mounted without distances heated by devices with same load

quadratic total current

$$\Sigma I_{th}^2 = I_{th1}^2 + I_{th2}^2 + I_{th3}^2 + I_{th4}^2 + I_{th5}^2$$

I_{th1} , I_{th2} , I_{th3} , I_{th4} , I_{th5} : thermal current I_{th} on contact rows

Application Examples

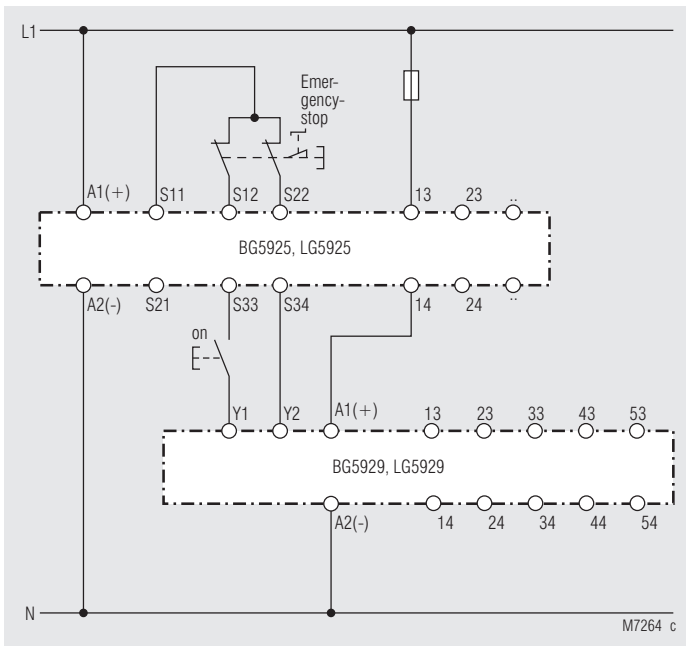

LG 5929, suited up to SIL3, Performance Level e, Cat. 4

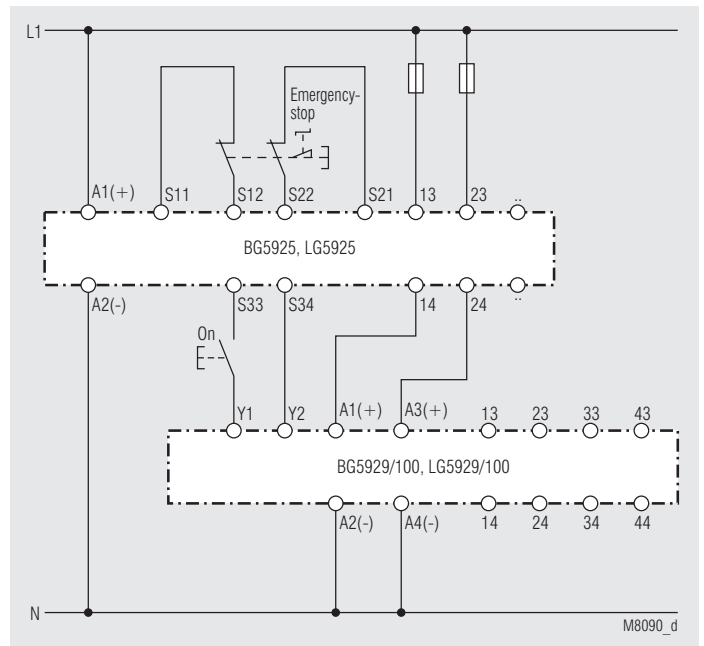

Contact multiplication with LG 5929/100, suited up to SIL3, Performance Level e, Cat. 4