

LIQUID CRYSTAL DISPLAY MODULE

Product Specification

PRODUCT NUMBER	84-0180-002T
PRODUCT DESCRIPTION	RIPDRAW, 7", 1024x600, LCD MODULE, TRMNS, WHT LED B/L, TFT, RoHS, GFF PCT, SMALL COVER GLASS

INTERNAL APPROVALS		
Product Manager	Engineering	Document Control

TABLE OF CONTENTS

1	GENERAL SPECIFICATIONS	4
2	FEATURES	4
3	MECHANICAL DRAWING	5
4	ABSOLUTE MAXIMUM RATINGS	6
5	BACKLIGHT CHARACTERISTICS	6
6	BLOCK DIAGRAM	7
7	ELECTRO-OPTICAL CHARACTERISTICS	8
8	CONNECTORS	12
8.1	POWER SUPPLY CONNECTOR (J1).....	12
8.2	LCD CONNECTOR (J2).....	12
8.3	PIC CONTOLLER OUTPUT (J3).....	13
8.4	PIC CONTROLLER PROGRAMMING (J4)	13
8.5	EEPROM PROGRAMMING (J5).....	13
8.6	EXTERNAL PWM AND ENABLE CONTROL (J6).....	13
8.7	EXTERNAL USB TOUCH CONNECTOR (J7).....	14
8.8	HDMI CONNECTOR (J8)	14
8.9	EXTERNAL I2C TOUCH CONNECTOR (J9)	14
8.10	TOUCH PAD CONNECTOR (J11)	15
9	JUMPERS CONFIGURATION	15
9.1	TOUCH INTERFACE VOLTAGE SELECTION (J10)	15
10	BASIC DISPLAY COLOR AND GRAY SCALE	16
11	RELIABILITY TEST	17
12	INCOMING INSPECTION STANDARDS	18
12.1	THE ENVIRONMENTAL CONDITION FOR INSPECTION	18
12.2	CLASSIFICATION OF DEFECTS AND AQL	18
12.3	INSPECTION PARAMETERS	19
13	HANDLING PRECAUTIONS	23

REVISION RECORD

Rev.	Date	Page	Par.	Comment	ECN No.
A	12/08/14	--	--	New DCA Spec	E5046

1 GENERAL SPECIFICATIONS

ITEM	DESCRIPTION	UNIT
Module Outline Dimensions	182.1 (H) x 125.46 (V) x 11.725 (T) (excluding cable)	mm
Active Display Area	152.80 (H) x 91.84 (V)	mm
Pixel Configuration Format / Resolution	1024 (H) x 600 (V)	pixels
LCD Type	Transmissive / Normally Black	--
Backlight Type	LED	--
Interface	HDMI	--
Luminance, White	352	cd/m ²
Dot Pitch	0.050 x 0.150	mm
Color Depth	6-bit + 2-bit FRC, 16.7M colors	--
Surface Treatment	Clear coating, 7H	--
RoHS Compliant	Yes	--

2 FEATURES

- The display module is a 7" diagonal WSVGA supported TFT-LCD and can display 16.7M colors (Hi FRC).
- Glass-film-film PCT, with USB interface.
- HDMI interface
- Solidworks model available with Densitron NDA on file.

3 MECHANICAL DRAWING

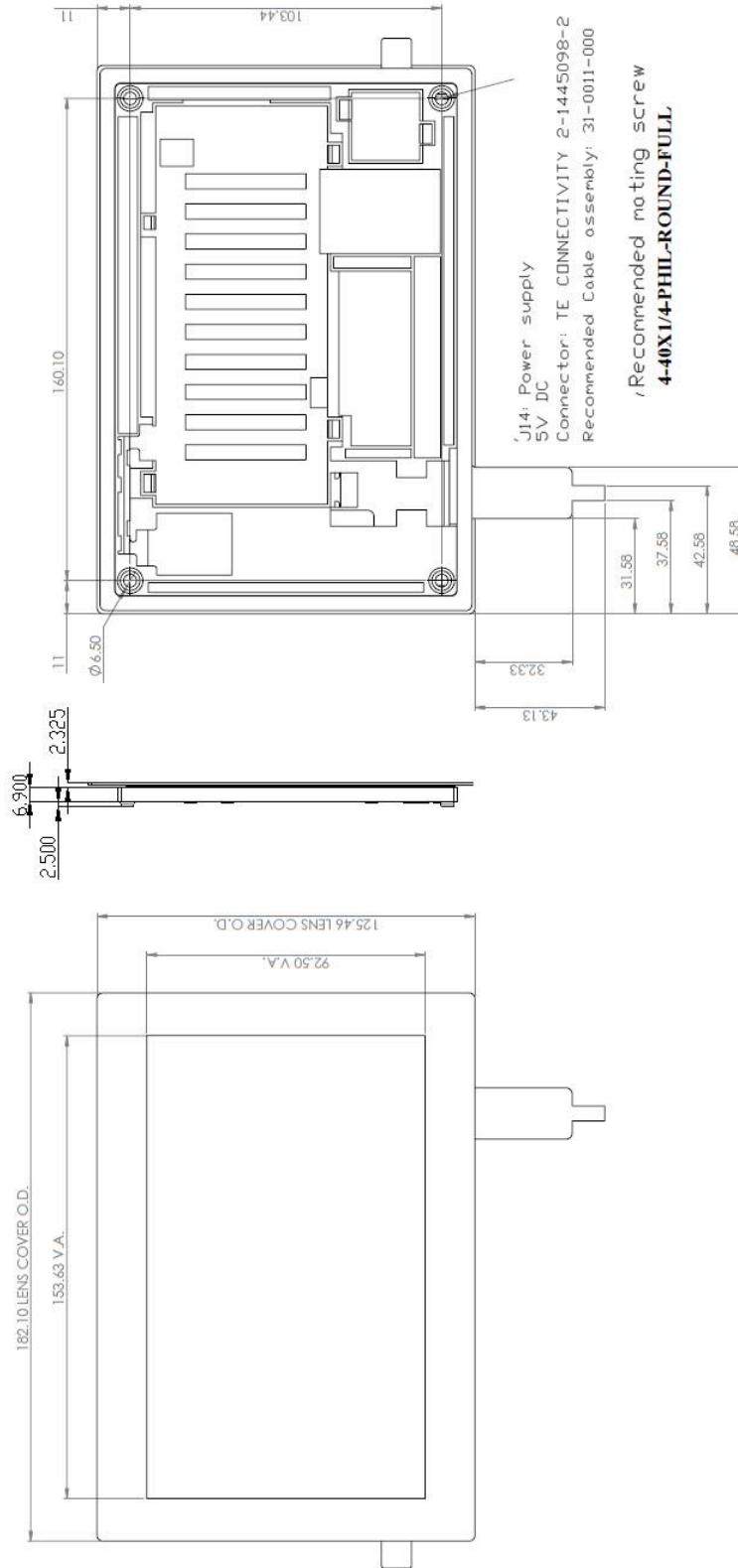

Product No.	84-0180-002T	REV. A
-------------	--------------	--------

Page	5 / 23
------	--------

4 ABSOLUTE MAXIMUM RATINGS

The following are maximum values which, if exceeded, may cause faulty operation or damage to the unit.

Parameter	Symbol	Values		Unit	Notes
		Min	Max		
Power Input Voltage	V _{CC}	4.85	5.15	V _{DC}	at 25 ± 5°C
Operating Temperature	T _{OP}	0	65	°C	1 - 4
Storage Temperature	H _{ST}	-10	70	°C	1 - 2

Note:

1. This rating applies to all parts of the module and should not be exceeded.
2. Maximum wet-bulb temperature is 46°C. Condensation of dew must be avoided as electrical current leaks will occur, causing a degradation of performance specifications.
3. The operating temperature only guarantees operation of the circuit and does not guarantee all the contents of Electro-Optical specification.
4. Ambient temperature when the backlight is lit (reference value).

5 BACKLIGHT CHARACTERISTICS

Parameter	Symbol	Min	Typ	Max	Unit	Notes
LED Forward Current	I _F	--	20	21	mA	Ta=25°C (per chain)
LED Forward Voltage	V _F	--	21	23.1	V	Ta=25°C (@ 20mA)
Power Consumption	P _{BL}	--	1,260	1,386	mW	Ta=25°C (@ 20mA)

Note:

1. The permissible forward current of LED vary with environmental temperature.

Nichia LED

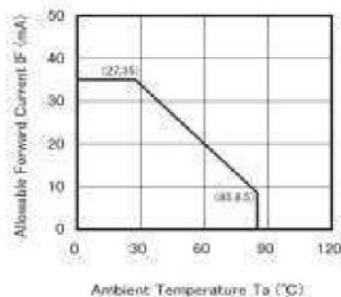

LED Array Structure

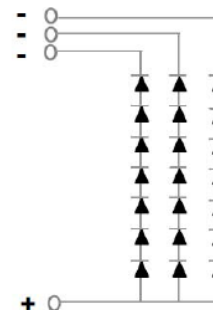

6 BLOCK DIAGRAM

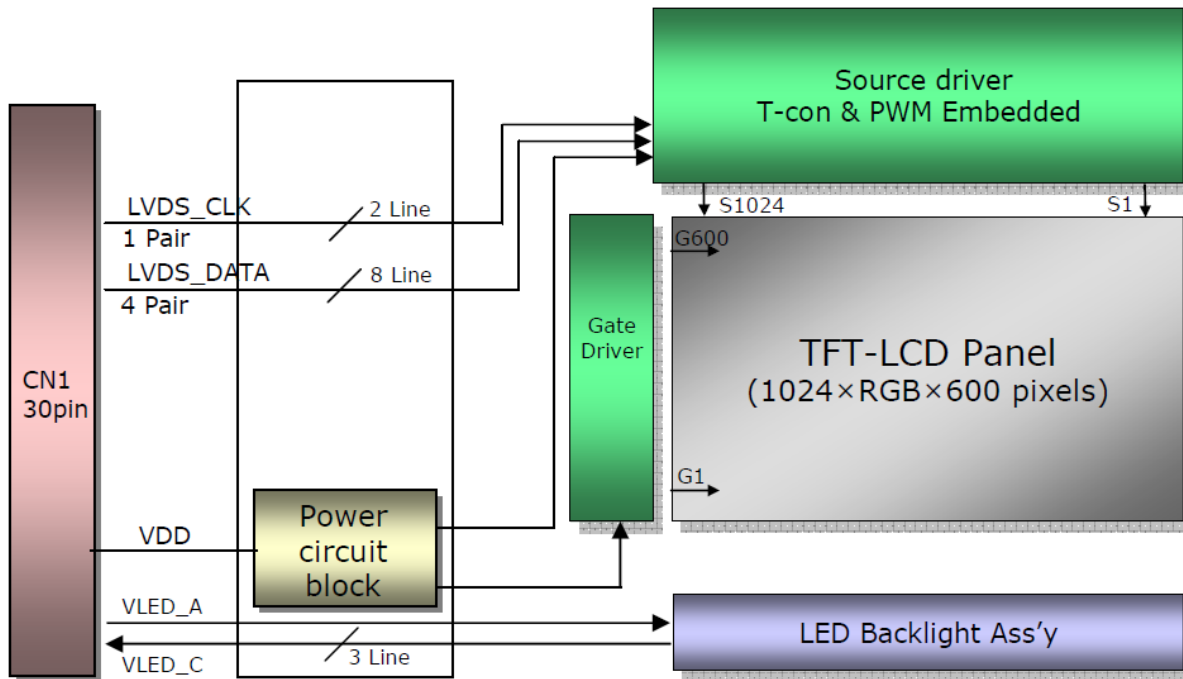

7 ELECTRO-OPTICAL CHARACTERISTICS

Ta=25°C, VCC=3.3V, fv=60Hz, fCLK=51.2MHz

Parameter	Symbol	Values			Unit	Notes	
		Min	Typ	Max			
Contrast Ratio	CR	640	800	--	--	1	
Surface Luminance, White	L _{WH}	--	352	--	cd/m ²	@20mA, 2	
Luminance Variation	δ _{WHITE}	--	1.18	1.34	--	3	
Response Time (Rise Time + Decay Time)	T _{TR} + T _{TD}	--	--	40	ms	4	
Color Coordinates						2	
	Red	RX	0.572	0.607	0.642	--	--
		RY	0.317	0.352	0.387	--	--
	Green	GX	0.294	0.329	0.364	--	--
		GY	0.539	0.574	0.609	--	--
	Blue	BX	0.121	0.156	0.191	--	--
		BY	0.102	0.137	0.172	--	--
	White	WX	0.270	0.310	0.350	--	--
		WY	0.300	0.340	0.380	--	--
Viewing Angle						5	
	x axis, right (Φ=0°)	Θ _r	75	85	--	deg	3 O'clock
	x axis, left (Φ=180°)	Θ _l	75	85	--	deg	9 O'clock
	y axis, up (Φ=90°)	Θ _u	75	85	--	deg	12 O'clock
	y axis, down (Φ=270°)	Θ _d	75	85	--	deg	6 O'clock

Optical characteristics are determined after the unit has been ‘ON’ and stable for approximately 5 minutes in a dark environment at 25°C. The values specified are at an approximate distance 50 cm from the LCD surface at a viewing angle of Φ and Θ equal to 0°.

Fig 1 presents additional information concerning the measurement equipment and method.

FIG. 1 Optical Characteristic Measurement Equipment and Method

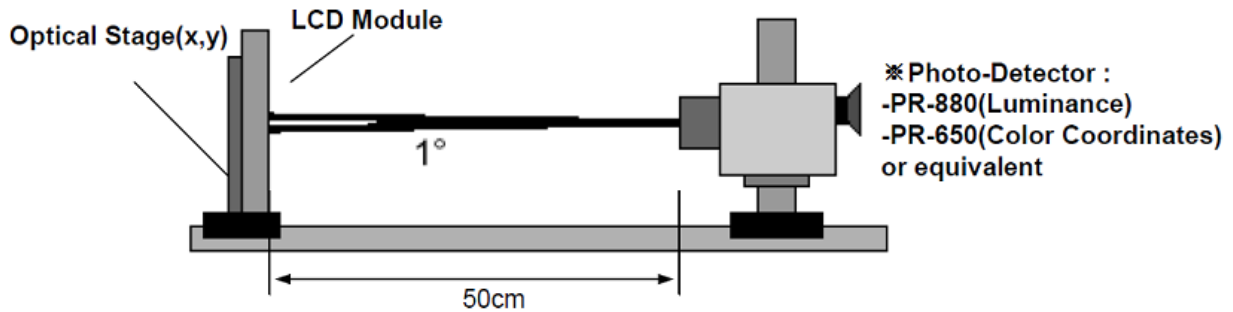

Note:

1. Contrast Ratio (CR) is defined mathematically as

$$\text{Contrast Ratio} = \frac{\text{Surface Luminance with all white pixels}}{\text{Surface Luminance with all black pixels}}$$

2. Surface luminance is measured at the center point (L_1) of the LCD with all pixels displaying white at the distance of 50 cm by PR-800. Color Coordinates are measured at the center point (L_1) of the LCD with all pixels displaying red, green, blue and white at the distance of 50 cm by PR-650. For more information, refer to Fig1 and Fig 2.

3. Luminance uniformity is measured for 9 points. For more information see Fig 2.

$$\delta_{\text{WHITE}} = \text{Maximum } (L_1, L_2, \dots, L_9) \div \text{Minimum } (L_1, L_2, \dots, L_9)$$

4. Response time is the time required for the display to transition from white to black (Rise Time, Tr_R) and from black to white (Decay Time, Tr_D). For additional information see Fig 3.
5. Viewing angle is the angle at which the Contrast Ratio is greater than 10. The angles are determined for the horizontal or x-axis, and the vertical or y-axis, with respect to the z axis which is normal to the LCD surface. For more information, see Fig 4.

FIG. 2 Luminance

measuring point for surface luminance & measuring point for luminance variation

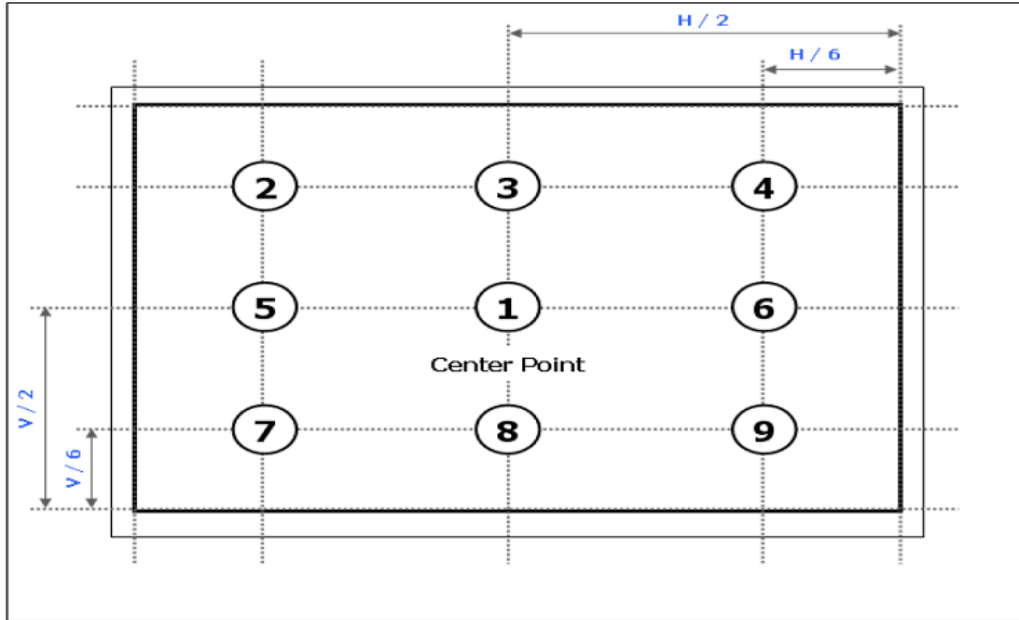

FIG. 3 Response Time

The response time is defined as the following figure and shall be measured by switching the input signal for "black" and "white".

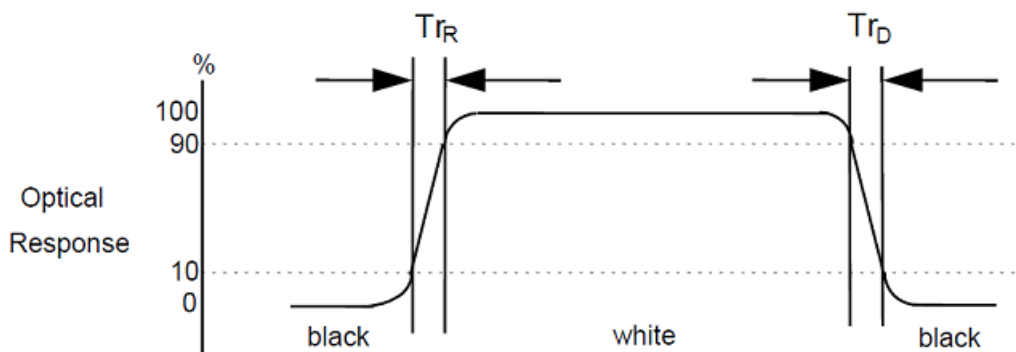
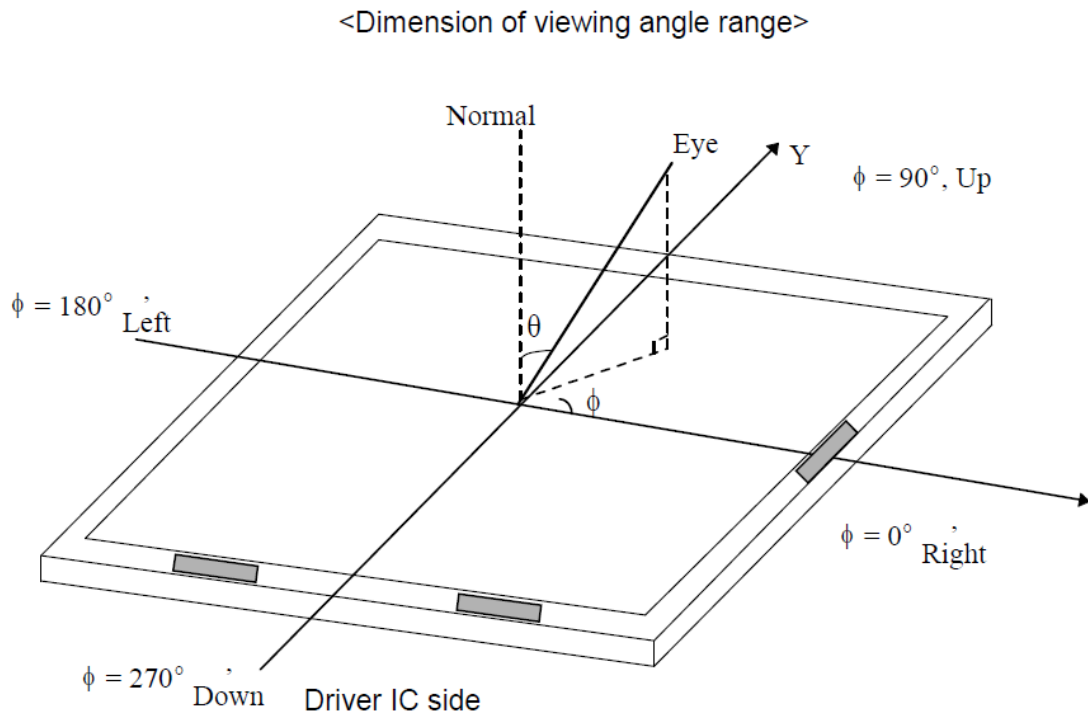
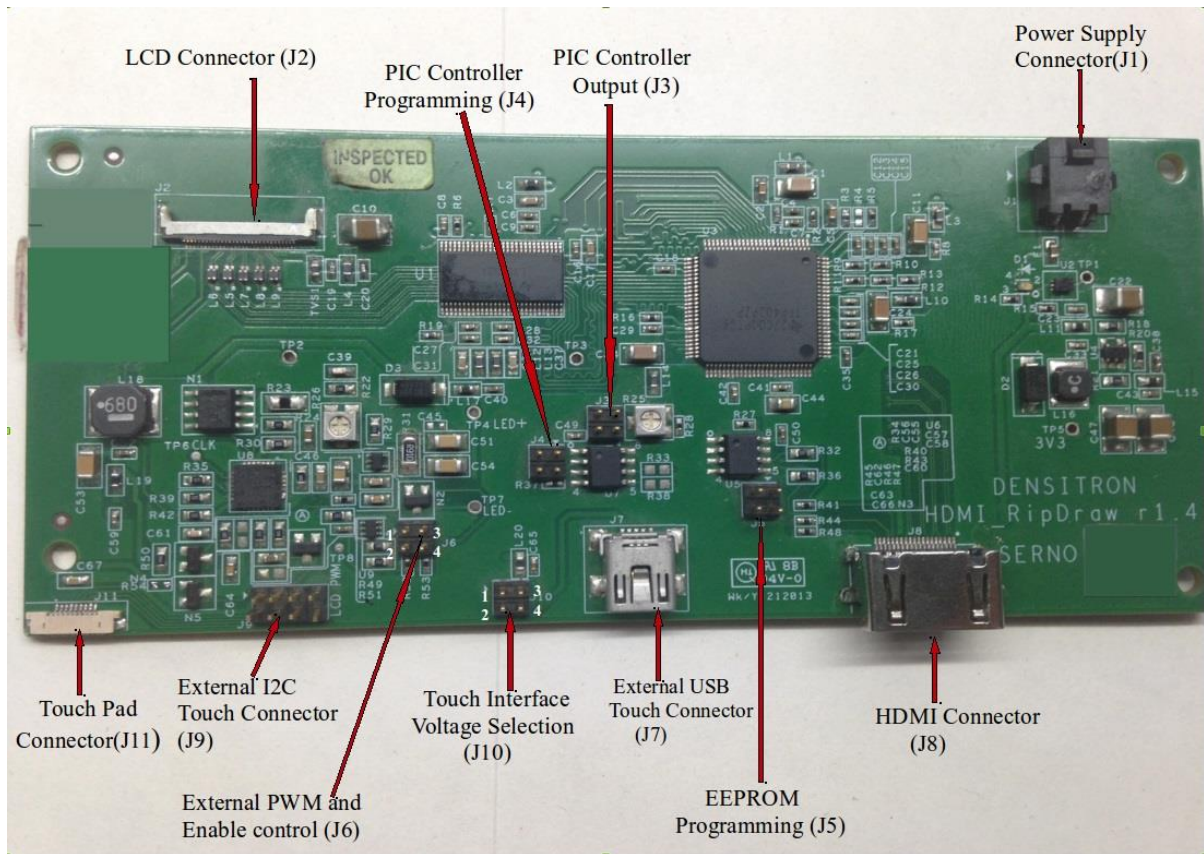

FIG. 4 Viewing angle



8 CONNECTORS



8.1 POWER SUPPLY CONNECTOR (J1)

Pin	Name	Description
1	5V	5V 2A DC
2	GND	Ground

8.2 LCD CONNECTOR (J2)

Pin	Name	Description
1	GND	Ground
2	NC	No Connection
3-4	VCC	3.3V 2A DC
5-6	VCC	3.3V 2A DC
7	GND	Ground
8	Y0M	Negative LVDS Differential 0th Data
9	Y0P	Positive LVDS Differential 0th Data

Product No.	84-0180-002T	REV. A
-------------	--------------	--------

Page	12 / 23
------	---------

10	GND	Ground
11	Y1M	Negative LVDS Differential 1st Data
12	Y1P	Positive LVDS Differential 1st Data
13	GND	Ground
14	Y2M	Negative LVDS Differential 2nd Data
15	Y2P	Positive LVDS Differential 2nd Data
16	GND	Ground
17	CLKM	Negative LVDS Differential CLK Data
18	CLKP	Positive LVDS Differential CLK Data
19	GND	Ground
20	Y3M	Negative LVDS Differential 3rd Data
21	Y3P	Positive LVDS Differential 3rd Data
22	GND	Ground
23	NC	No Connection
24-25-26	BL_LED+	Backlight LED Positive Terminal END
27	NC	No Connection
28-29-30	BL_LED-	Backlight LED Negative Terminal END

8.3 PIC CONTOLLER OUTPUT (J3)

Not installed on production version.

8.4 PIC CONTROLLER PROGRAMMING (J4)

Not installed on production version.

8.5 EEPROM PROGRAMMING (J5)

Pin	Name	Description
1	SCL	EEPROM SCL
2	TEST	EEPROM Test
3	SDA	EEPROM SDA
4	GND	Ground

8.6 EXTERNAL PWM AND ENABLE CONTROL (J6)

Pin	Name	Description
1	VCC	3.3V
2	PWM	PWM signal to controller backlight
3	GND	Ground
4	EN	Active high enable signal to on/off backlight

8.7 EXTERNAL USB TOUCH CONNECTOR (J7)

Pin	Name	Description
1	5V	5V power
2	D-	Data differential pair minus
3	D+	Data differential pair plus
4	ID	On the Go Identification
5	GND	Ground

8.8 HDMI CONNECTOR (J8)

Pin	Name	Description
1	Rx2+	Digital Input Channel2 True
2	GND	Ground
3	Rx2-	Digital Input Channel2 Complement
4	Rx1+	Digital Input Channel1 True
5	GND	No Connection
6	Rx1-	Digital Input Channel1 Complement
7	Rx0+	Digital Input Channel0 True
8	GND	Ground
9	Rx0-	Digital Input Channel0 Complement
10	RxC+	Digital Data Clock True
11	GND	Ground
12	RxC-	Digital Data Clock Complement
13-14	NC	No Connection
15-16	NC	No Connection
17	GND	Ground
18-19	NC	No Connection
20-21	GND	Ground
22-23	GND	Ground

8.9 EXTERNAL I2C TOUCH CONNECTOR (J9)

Pin	Name	Description
1	VCC	3.3/5V 2A DC
2	TS_INT	GPIO Interrupt Signal
3	NC	No connection
4	TS_RESET	GPIO Reset Signal
5	NC	No connection
6	TS_SDA	I2C Data Signal
7	GND	Ground
8	TS_SCL	I2C Clock Signal

8.10 TOUCH PAD CONNECTOR (J11)

Pin	Name	Description
1	VCC	5V/3.3V 2A DC
2	NC	No Connection
3	NC	No Connection
4	GND	Ground
5	TS_INT	GPIO Interrupt Signal
6	TS_RESET	GPIO Reset Signal
7	TS_SDA	I2C Data Signal
8	TS_SCL	I2C Clock Signal
9	GND	Ground

9 JUMPERS CONFIGURATION

9.1 TOUCH INTERFACE VOLTAGE SELECTION (J10)

This jumper used to set the Touch Panel operating voltage selection.

Pin	Description
1-2	USB 5V, for USB touch interface voltage
3-4	I2C 3.3V, for I2C touch interface voltage

11 RELIABILITY TEST

No.	Test Item	Test Condition
1	High Temperature Storage	70 ± 2°C / 240 hours
2	Low Temperature Storage	-10 ± 2°C / 240 hours
3	High Temperature Operation	65 ± 2°C / 240 hours
4	Low Temperature Operation	0 ± 2°C / 240 hours
5	Temperature Cycle	-10 ± 2°C ~ 70°C (0.5hr.) x 50 Cycles
6	Proof against Dampness	50 ± 5°C X 90% RH / 120 hours; Pure Water Used (Resistance > 10 MΩ)
7	Vibration Test	Frequency: 10 Hz ~ 55 Hz ~ 10 Hz Amplitude: 1.5 mm X,Y & Z directions for a total of 3 hours
8	Dropping Test	Dropped to the ground from 1 m height, one time and tested on all sides of the carton when packed.
9	ESD Test	- Panel Surface / Top Case : 150pF, 150Ω (Air: ±15kV, Contact: ± 8kV -FPC input terminal: 100pF ± 200V 0Ω
Inspection after Test		The sample is tested for the following defects after 2 ~ 4 hours of storage at room temperature: <ul style="list-style-type: none"> 1. Air bubbles in the LCD 2. Leaking Seal 3. No Display 4. Missing Segments 5. Glass Cracks 6. I_D current is higher than twice the initial value
Remarks: <ol style="list-style-type: none"> 1. The test samples are applicable to only one test group. 2. Sample size for each test group is 5 ~ 10 pieces. 3. In case of a malfunction caused by ESD test, if it recovers to the normal state after resetting, it would be judged as a good part. 4. EL backlights can produce black spots/blemishes in humidity and temperature test due to natural chemical reactions and fluorescence. This is checked for. 5. Please use automatic switch menu (or roll menu) in test mode. 		

12 INCOMING INSPECTION STANDARDS

12.1 THE ENVIRONMENTAL CONDITION FOR INSPECTION

The environmental condition and visual inspection shall be conducted as below.

1. Ambient temperature: $25 \pm 5^{\circ}\text{C}$
2. Humidity: $60 \pm 5\%$ RH
3. Viewing distance: 35 ~ 40 cm approx.
4. Viewing angle: Normal to the LCD panel as shown below
5. Ambient Illumination: 300 ~ 500 Lux. for external appearance inspection.

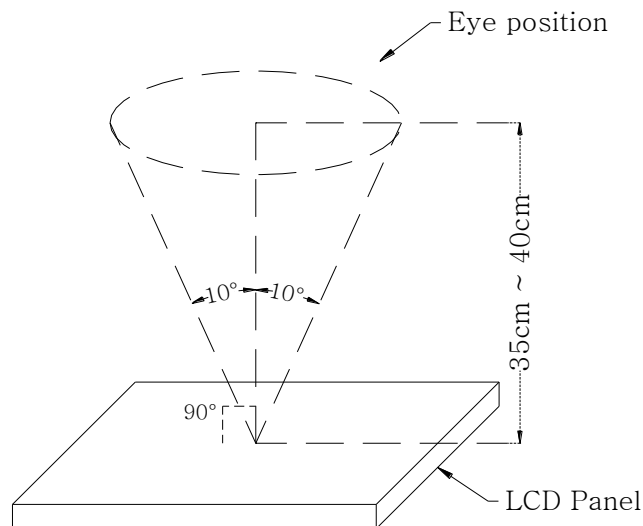

12.2 CLASSIFICATION OF DEFECTS AND AQL

Class of Defects	AQL	Definition
Major	1.0%	It is a defect that is likely to result in failure or to reduce materially the usability of the intended function.
Minor	1.5%	It is a defect that will not result in a functioning problem with deviation classified.

Note: Sampling plan according to GB / T2828.1-2003 / ISO 2859-1:1999 and ANSI/ASQC Z1.4-1993, Normal level 2.

12.3 INSPECTION PARAMETERS

Item		Specification / Description			Note	
Display	Function	No display			-	
		Malfunction			-	
Operating	Contrast ratio	Out of spec.			-	
	Line defect	No obvious Vertical and Horizontal line defects for the bright, dark and colored.			-	
	Point defect (red, green, blue, black, white)	Item	Acceptable number			1, 4, 5, 6
			A	B	Total	
		Bright dot	$N \leq 2$	$N \leq 2$	$N \leq 7$	
		Black / dark dot	$N \leq 3$	$N \leq 4$		
		Total dots	$N \leq 4$	$N \leq 5$		
		Two adjacent dots	Not allowed			
Three or more adjacent dots	Not allowed					
External Inspection (Non-operating)	Scratch on the Polarizer	L (mm)	W (mm)	Acceptable number	2	
		$L \leq 2.5$	$W \leq 0.1$	4		
		$L > 2.5$	$W > 0.1$	0		
	Dent or bubble on the polarizer	Dimension (mm)		Acceptable number	3	
		$D \leq 0.5$		4		
		$D \leq 0.15$		Disregard		
	Foreign material on the polarizer	Dimension (mm)		Acceptable number	3	
		$D \leq 0.5$		4		
		$D \leq 0.15$		Disregard		

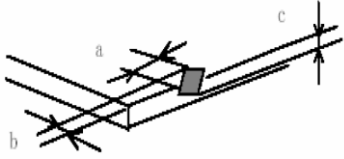
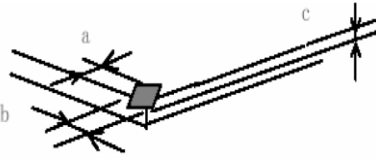
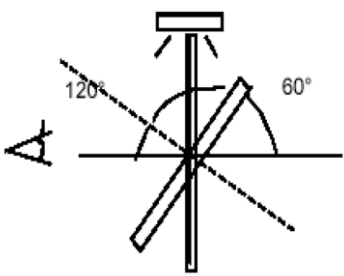
Item		Specification / Description			Note
Touch Panel (If Present)	Scratch	L (mm)	W (mm)	Acceptable number	2
		L ≤ 10	W < 0.05	Disregard	
			0.05 ≤ W < 0.1	N ≤ 4	
			W ≥ 0.1	0	
	Foreign materials (Linear shape)	L ≤ 10	W < 0.05	Disregard	2
			0.05 ≤ W < 0.1	N ≤ 3	
			W ≥ 0.1	0	
	Foreign materials (Circular shape)	Dimension (mm)		Acceptable number	3
		D ≤ 0.25		Disregard	
		0.25 < D ≤ 0.5		N ≤ 6	
D > 0.5		0			
Glass chips			a ≤ 5mm b ≤ 3mm c ≤ t (t: Glass Thickness)	7	
			a ≤ 3mm b ≤ 3mm c ≤ t (t: Glass thickness)		
Newton's rings	(In case of doubtful situations only) Observe at 60° from the product surface for a while under a Fluorescent lamp. (3-Wavelength lamp)			If Average Diameter ≤ (1/3) Touch Panel Area, Disregard.	7

Notes:

1. The definition of dot defect: The dot defect was judged after repair and the size of a defective dot with size over 1/2 of one standard dot is regarded as one defective dot.

2.

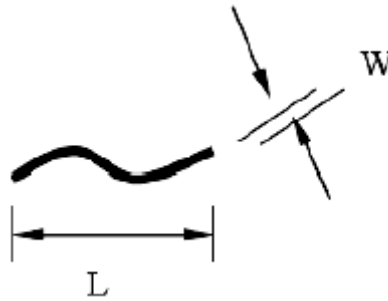

3. Diameter - $D = (a + b) / 2$

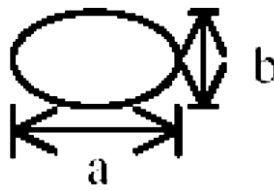

4. A bright dot is defined with 6% transmission ND filter as shown below:

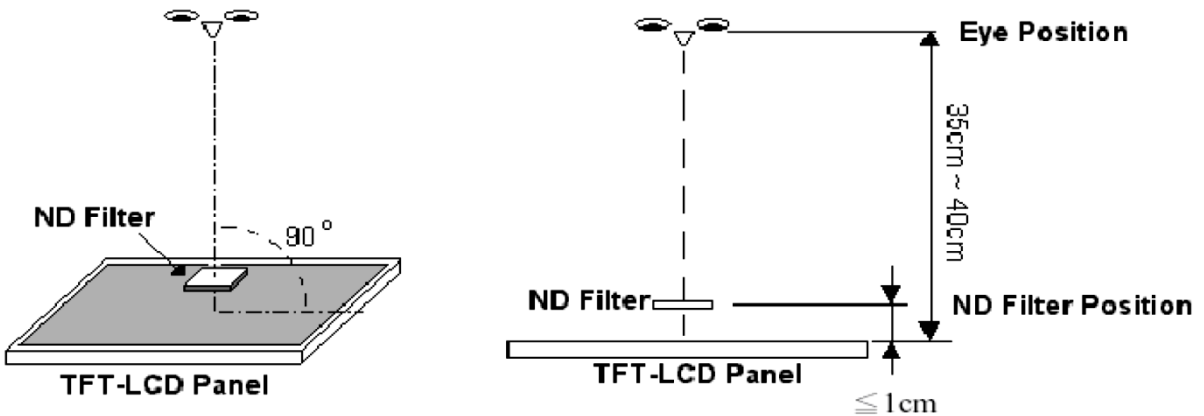

5. Adjacent Dots:



6.

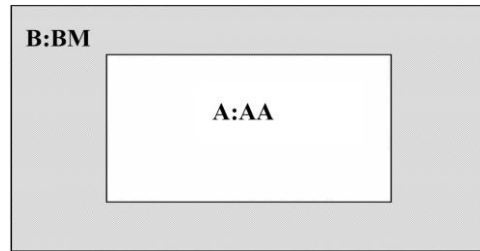

7.

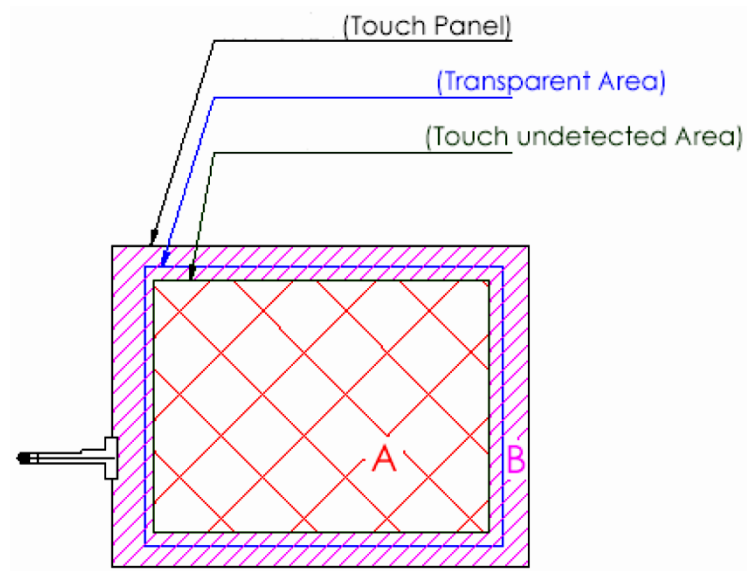

A: Area without any defect point effect on normal operation
B: Defects are not specified in this area

General Installation and Assembly Diagram:

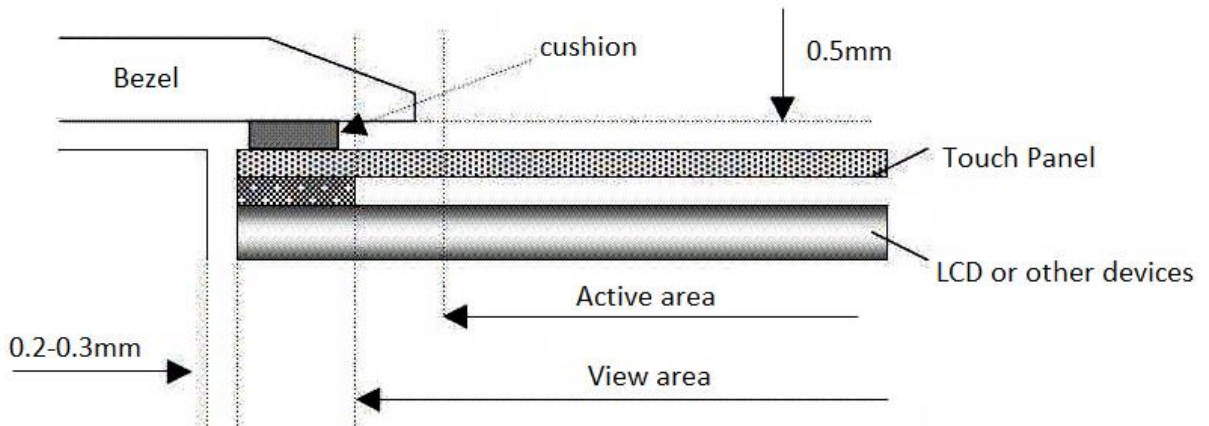

13 HANDLING PRECAUTIONS

Safety

If the LCD panel breaks, be careful not to get the liquid crystal fluid in your mouth or in your eyes. If the liquid crystal touches your skin or clothes, wash it off immediately using soap and plenty of water.

Mounting and Design

Place a transparent plate (e.g. acrylic, polycarbonate or glass) on the display surface to protect the display from external pressure. Leave a small gap between the transparent plate and the display surface. When assembling with a zebra connector, clean the surface of the pads with alcohol and keep the surrounding air very clean. Design the system so that no input signal is given unless the power supply voltage is applied.

Caution during LCD cleaning

Lightly wipe the display surface with a soft cloth soaked with Isopropyl alcohol, Ethyl alcohol or Trichlorotrifluoroethane. Do not wipe the display surface with dry or hard materials that will damage the polarizer surface. Do not use aromatic solvents (toluene and xylene), or ketonic solvents (ketone and acetone).

Caution against Static Charge

As the display uses C-MOS LSI drivers, connect any unused input terminals to VDD or VSS. Do not input any signals before power is turned on. Also, ground your body, work / assembly table and assembly equipment to protect against static electricity.

Packaging

Displays use LCD elements, and must be treated as such. Avoid strong shock and drop from a height. To prevent displays from degradation, do not operate or store them exposed directly to sunlight or high temperature / humidity.

Caution during Operation

It is indispensable to drive the display within the specified voltage limit since excessive voltage shortens its life. Direct current causes an electrochemical reaction with remarkable deterioration of the display quality. Give careful consideration to prevent direct current during ON/OFF timing and during operation. Response time is extremely delayed at temperatures lower than the operating temperature range while, at high temperatures, displays become dark. However, this phenomenon is reversible and does not mean a malfunction or a display that has been permanently damaged. If the display area is pushed on hard during operation, some graphics will be abnormally displayed but returns to a normal condition after turning off the display once. Even a small amount of condensation on the contact pads (terminals) can cause an electrochemical reaction which causes missing rows and columns. Give careful attention to avoid condensation.

Storage

Store the display in a dark place where the temperature is $25^{\circ}\text{C} \pm 10^{\circ}\text{C}$ and the humidity below 50% RH. Store the display in a clean environment, free from dust, organic solvents and corrosive gases. Do not crash, shake or jolt the display (including accessories).

Product No.	84-0180-002T	REV. A
-------------	--------------	--------

Page	23 / 23
------	---------