

Insulated Enclosure KO 4913

for surface mounting and mounting in cabinets,
with cage clamp terminals

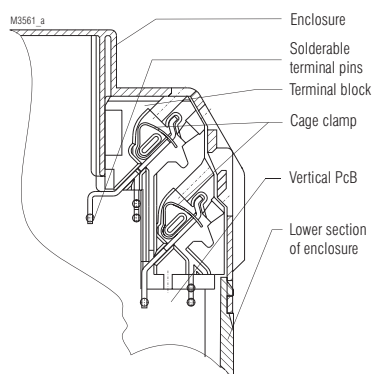

- Width 35 mm
- Max. 16 terminals with each 2 cage clamp terminals
- Machine solderable connections
- Housing supplied as single parts, terminals prefitted in terminal blocks



Cage clamp for soldering

Technical Data

Order reference:	KO 4913.0050313	
Outer dimensions:	35 x 90 x 97 mm	
Enclosure material:	PC-GF, light grey RAL 7035	
Temperature stability:		
complying with UL 746 B:	125 °C	
complying with Vicat ISO 306	Meth. B:	148 °C
complying with ISO 75-2	Meth. A:	138 °C
	Meth. B:	144 °C
Max. permitted power dissipation:	9 W for stand-alone enclosure at normal climate 23/50-1	ISO 554
Specific thermal resistance:	$R_{th} = 6 \text{ K / W}$ for stand-alone enclosure	
Flame retardancy		
complying with UL 94:	V-0	
complying with IEC 60 707:	BH 2-30	
Number of terminals:	16; < 16 on request	
Terminal material:	High grade steel / Copper alloy, tin-plated	
Max. cross section for connection:	2 x 1,5 mm ² solid or 2 x 1,5 mm ² stranded or 2 x 1 mm ² stranded ferruled min. Ø 0,1mm solid AWG 24	DIN 46 228-1/-2/-3/-4
Insulation of wires length:	8 mm	
Max. contact resistance to printed circuit board:	10 mΩ	
Max. current carrying capacity:	10 A	
Wire fastening:	Cage clamps	
Required tool:	Screwdriver	
Inner connection:	Machine-solderable terminal pins for PCB	
Enclosure fastener:	1) Snap-on fastener on top hat rail EN 50 022 2) Screw fixing M4, grid 90 mm with second clip as accessory	
Creepage current resistance:	CTI 175 ≙ insulated material III a	IEC 60 664-1
Air gap and creepage distance:	≥ 4 mm	IEC 60 664-1
Type of protection	IEC 60 529	
Enclosure:	IP 40	
Terminals:	IP 20	
	Contact protection complies with VBG 4	
Print area:	44 mm on the front and 35 x 8 mm above the terminals	
Printed circuit board:	See printed circuit board design	
Printed circuit board holder:	Guide ribs	
Component installation height for a vertical printed circuit board		
on component side:	≤ 29 mm	
on soldering side:	≤ 2,0 mm bzw. 1,4 mm (see PCB design)	
Net weight:	105 g	
Accessories:		
ET 4086-0-2:	Second clip for screw fixing	

Exploded view

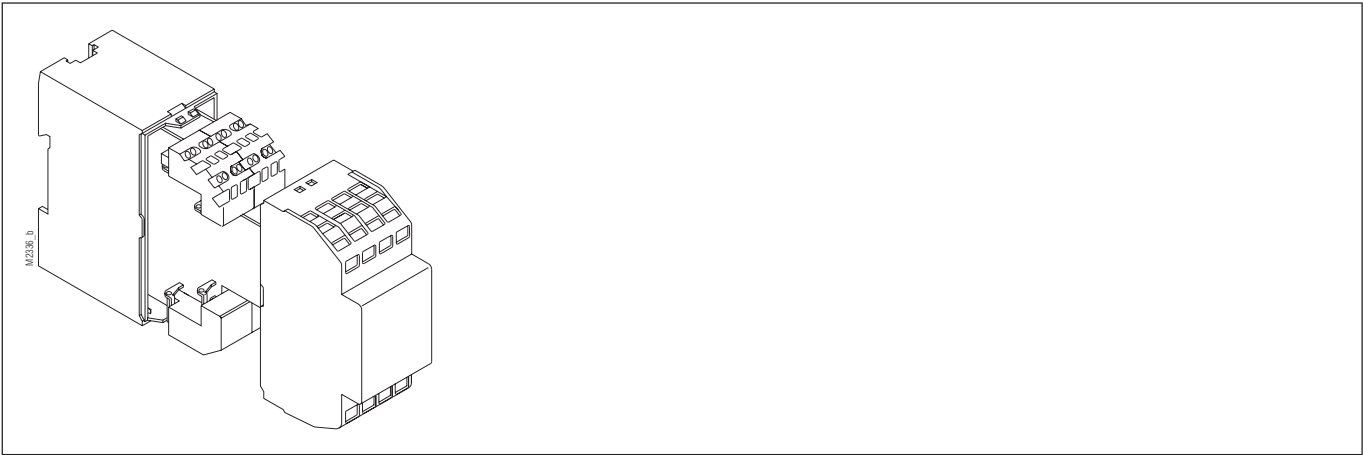

Dimensions

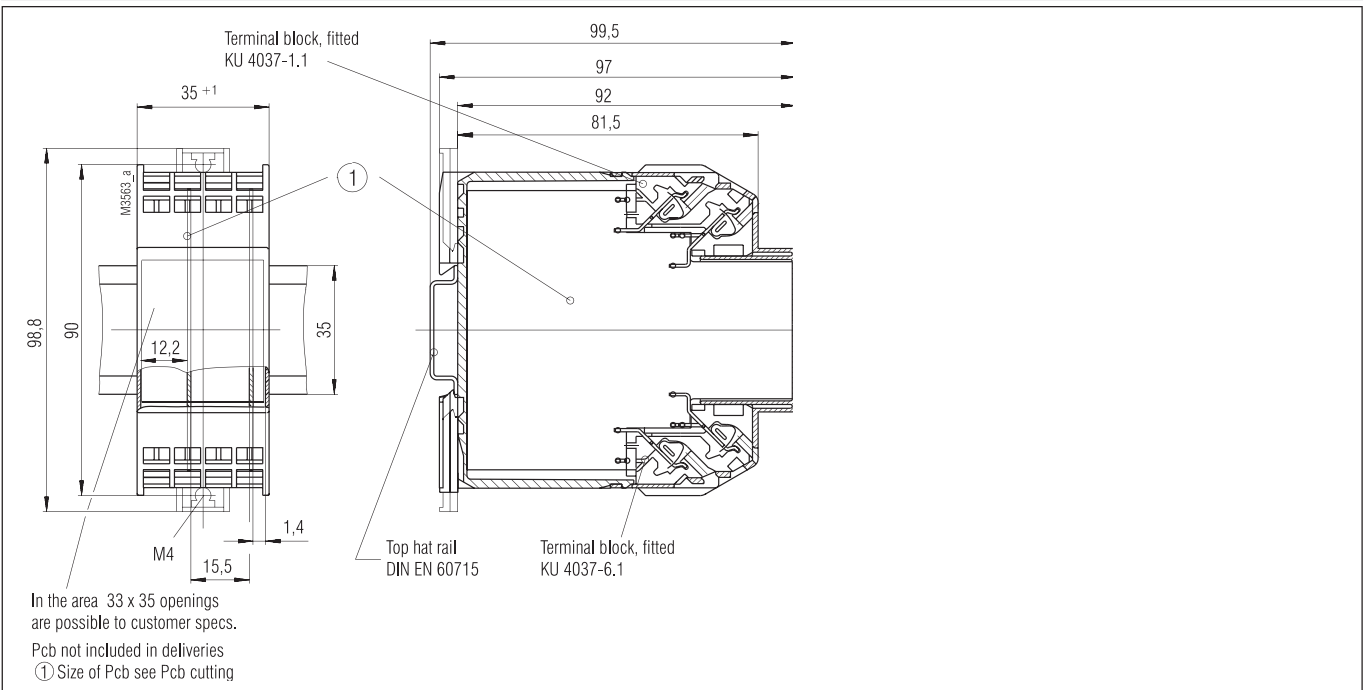

Printed circuit board design

