

# LIQUID CRYSTAL DISPLAY MODULE

## Product Specification

<b>CUSTOMER</b>	<b>Standard</b>	
<b>PRODUCT NUMBER</b>	<b>TSR4855 / TSR6855</b>	
<b>CUSTOMER APPROVAL</b>		<b>Date</b>

INTERNAL APPROVALS		
Product Mgr	Doc Control	Electr. Eng
<b>Bruno Recaldini</b>	<b>Anthony Perkins</b>	<b>Bazile Peter</b>
Date:20/09/06	Date: 20/09/06	Date:20/09/06

- Approval for Specification only
- Approval for Specification and Sample

# TABLE OF CONTENTS

<b>1</b>	<b>MAIN FEATURES .....</b>	<b>4</b>
<b>2</b>	<b>MECHANICAL SPECIFICATION.....</b>	<b>5</b>
2.1	MECHANICAL CHARACTERISTICS .....	5
2.2	MECHANICAL DRAWING .....	6
<b>3</b>	<b>ELECTRICAL SPECIFICATION.....</b>	<b>7</b>
3.1	ABSOLUTE MAXIMUM RATINGS .....	7
3.2	ELECTRICAL CHARACTERISTICS .....	7
3.3	INTERFACE PIN ASSIGNMENT CCFL .....	9
3.4	INTERFACE PIN ASSIGNMENT LED .....	10
3.5	POWER SUPPLY CIRCUIT .....	11
3.6	CHARACTER GENERATOR ROM MAP .....	12
3.7	CHARACTER CODES .....	13
3.8	TIMING CHARECTERISTICS.....	14
<b>4</b>	<b>OPTICAL SPECIFICATION.....</b>	<b>15</b>
4.1	OPTICAL CHARACTERISTICS.....	15
<b>5</b>	<b>TOUCH PANEL CHARACTERISTICS.....</b>	<b>18</b>
<b>6</b>	<b>BACKLIGHT SPECIFICATION .....</b>	<b>20</b>
6.1	BACKLIGHT CHARACTERISTICS.....	20
<b>7</b>	<b>LABELLING &amp; MARKING.....</b>	<b>21</b>
<b>8</b>	<b>QUALITY ASSURANCE SPECIFICATION .....</b>	<b>22</b>
8.1	CONFORMITY .....	22
8.2	DELIVERY ASSURANCE .....	22
8.3	DEALING WITH CUSTOMER COMPLAINTS .....	27
<b>9</b>	<b>RELIABILITY SPECIFICATION .....</b>	<b>28</b>
9.1	RELIABILITY TESTS .....	28
9.2	LIFE TIME.....	28
<b>10</b>	<b>PART NUMBER DESCRIPTIONS FOR AVAILABLE OPTIONS .....</b>	<b>29</b>
<b>11</b>	<b>HANDLING PRECAUTIONS.....</b>	<b>30</b>

Product No.	TSR4855 / TSR6855	REV. A

Page	2 / 30
------	--------

REVISION RECORD

Rev.	Date	Page	Chapt.	Comment	ECR no.
A	20/09/06			Product release	

Product No.	TSR4855 / TSR6855	REV. A

Page	3 / 30
------	--------

# 1 MAIN FEATURES

ITEM	CONTENTS
Display Format	320 x 240 dots
Overall Dimensions (exc. cables)	165.5 x 109.0 x 16.0 w/o (NV & TC) LED 165.5 x 109.0 x 20.2 with (NV and TC) LED 173.0 x 109.0 x 16.0 w/o (NV & TC) CCFL 173.0 x 109.0 x 20.2 with (NV and TC) CCFL
Viewing Area	122 x 92
LCD type	STN Blue mode or FSTN
Mode	Transflective or Transmissive
Viewing Angle	6 O clock
Duty ratio	1 / 240
Driver IC	Raio RA8835
Backlight type	LED TSR4855 CCFL TSR6855
Backlight colour	White
DC/DC converter	Optional
Temperature compensation	Optional
Operating temperature standard	0 ~ 50°C
Storage temperature standard	-20 ~+70C
Operating temperature wide	-20 ~ +70°C
Storage temperature wide	-30 ~ +80°C
RoHS status	Compliant

Product No.	TSR4855 / TSR6855	REV. A

Page	4 / 30
------	--------

## 2 MECHANICAL SPECIFICATION

### 2.1 MECHANICAL CHARACTERISTICS

ITEM	CHARACTERISTIC	UNIT
Display Format	320 x 240 dots	
Overall Dimensions (exc. cables)	165.5 x 109.0 x 16.0 w/o (NV & TC) LED 165.5 x 109.0 x 20.2 with (NV and TC) LED 173.0 x 109.0 x 16.0 w/o (NV & TC) CCFL 173.0 x 109.0 x 20.2 with (NV and TC) CCFL	mm
Viewing Area	122 x 92	mm
Active Area	115.185 x 86.385	mm
Dot Size	0.345 x 0.345	mm
Dot spacing	0.015	mm
IC Controller/Driver	Raio RA8835	

Product No.	TSR4855 / TSR6855	REV. A

Page	5 / 30
------	--------

## 2.2 MECHANICAL DRAWING

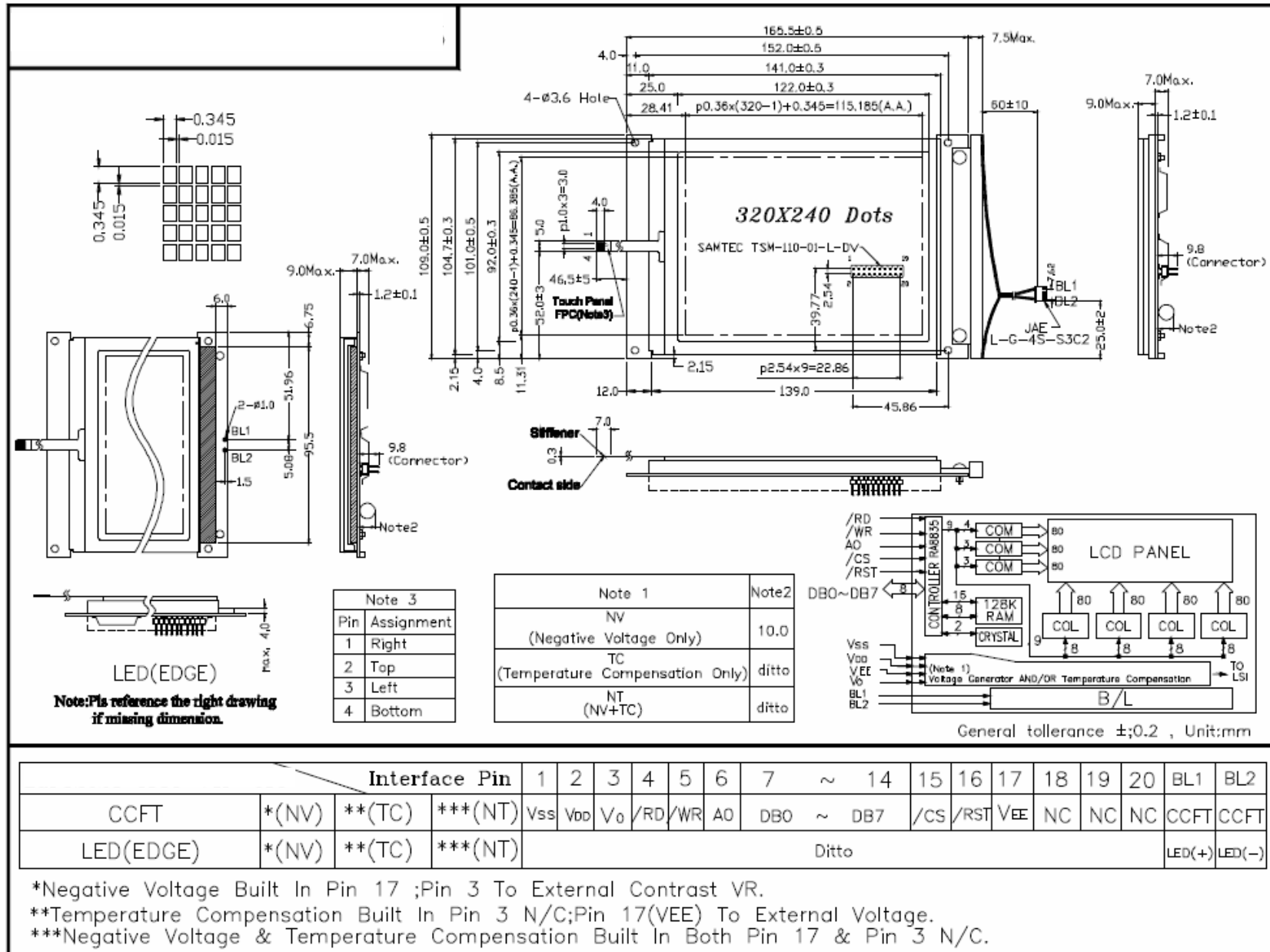

### 3 ELECTRICAL SPECIFICATION

#### 3.1 ABSOLUTE MAXIMUM RATINGS

VSS = 0 V, Ta = 25 °C

Item	Symbol	Min	Max	Unit	Note
Power Supply Voltage	V <sub>DD</sub>	0	7	V	
Operating Temperature	T <sub>opr</sub>	0	50	°C	<65%RH (standard temp)
		-20	+70	°C	<65%RH (wide temp)
Storage Temperature	T <sub>stg</sub>	-20	+70	°C	<65%RH (standard temp)
		-30	+80	°C	<65%RH (wide temp)
Humidity	H	20	+90	%RH	< 48Hrs
		20	+65	%RH	< 1000Hrs
Static Electricity	Be sure that you are grounded when handling displays.				

#### 3.2 ELECTRICAL CHARACTERISTICS

VSS = 0 V, Ta = 25 °C

Item	Symbol	Condition	Min	Typ	Max	Unit
Operating voltage	V <sub>DD</sub>		4.75	-	5.25	V
Input voltage High	V <sub>IHC</sub>		3.8	-	V <sub>DD</sub>	V
Input voltage Low	V <sub>ILC</sub>		0	-	1.0	V
LCD driving voltage	V <sub>DD-V<sub>O</sub></sub>		6	-	28	V

### 3.2.1 Current Consumption & Driving Voltage

	FSTN Temperature (Positive)		FSTN Temperature (Negative)		STN Temperature	
	Standard	Wide	Standard	Wide	Standard	Wide
Supply Current (IDD) Typ mA	10	10	10	10	10	10
Supply Current (IEE) Typ mA	6	6	6	6	6	6
Supply Voltage (VEE) Typ	-22	-22	-22	-22	-22	-22

### 3.2.2 Recommended LCD drive voltage

		FSTN Temperature (Positive)		FSTN Temperature (Negative)		STN Temperature	
		Standard	Wide	Standard	Wide	Standard	Wide
LCD driving voltage	Ta=70°C	N/A	24.5	N/A	24.4	N/A	25.3
	Ta=50 °C	23.3	23.3	23.0	23.0	23.7	23.7
	Ta=25 °C	22.5	22.5	22.2	22.2	22.8	22.7
	Ta=0 °C	21.7	21.7	21.4	21.4	21.7	21.4
	Ta=-20 °C	N/A	21.7	N/A	20.4	N/A	20.4

### 3.2.3 Single +5V operation (with optional DC/DC converter - backlight not included)

Negative voltage (NV) built in. IDD = 85mA typ

Negative voltage (NV) and Temperature compensation (TC) built in. IDD = 85mA typ.

Product No.	TSR4855 / TSR6855	REV. A

Page	8 / 30
------	--------



### 3.3 INTERFACE PIN ASSIGNMENT CCFL

No.	Symbol	Level	Function
1	V <sub>SS</sub>	-	Ground
2	V <sub>DD</sub>	-	Power supply for logic
3	V <sub>O</sub>	-	Voltage level for LCD Control adjustment
4	/RD	H/L	8080 family: Read signal 6800 family: Enable clock (E)
5	/WR	H/L	8080 family: Write signal 6800 family: R/W signal
6	A0	H/L	Data type select <span style="float: right;">Note 1</span>
7	DB0	H/L	Display data 0
8	DB1	H/L	Display data 1
9	DB2	H/L	Display data 2
10	DB3	H/L	Display data 3
11	DB4	H/L	Display data 4
12	DB5	H/L	Display data 5
13	DB6	H/L	Display data 6
14	DB7	H/L	Display data 7
15	/CS	H/L	Chip select
16	/RST	L	Reset signal
17	V <sub>ee</sub>	-	Alternative power supply
18	FG	-	Frame GND
19	N/C		No connection
20	N/C		No connection
BL1	CCFT		CCFT
BL2	CCFT		CCFT

Product No.	TSR4855 / TSR6855	REV. A

Page	9 / 30
------	--------

### 3.4 INTERFACE PIN ASSIGNMENT LED

No.	Symbol	Level	Function
1	V <sub>SS</sub>	-	Ground
2	V <sub>DD</sub>	-	Power supply for logic
3	V <sub>o</sub>	-	Voltage level for LCD Control adjustment
4	/RD	H/L	8080 family: Read signal 6800 family: Enable clock (E)
5	/WR	H/L	8080 family: Write signal 6800 family: R/W signal
6	A0	H/L	Data type select <span style="float: right;">Note 1</span>
7	DB0	H/L	Display data 0
8	DB1	H/L	Display data 1
9	DB2	H/L	Display data 2
10	DB3	H/L	Display data 3
11	DB4	H/L	Display data 4
12	DB5	H/L	Display data 5
13	DB6	H/L	Display data 6
14	DB7	H/L	Display data 7
15	/CS	H/L	Chip select
16	/RST	L	Reset signal
17	V <sub>ee</sub>	-	Alternative power supply
18	N/C	-	No connection
19	N/C		No connection
20	N/C		No connection
BL1	LED(+)	H	Anode of LED B/L
BL2	LED(-)	L	Cathode of LED B/L

Product No.	TSR4855 / TSR6855	REV. A

Page	10 / 30
------	---------

Note 1: A0, in conjunction with the /RD and /WR or R/W and E signals control the type of access to the RA8835. The description is below.

A0	/RD	/WR	Function
0	0	1	Status flag read
1	0	1	Display data and cursor address read
0	1	0	Display data and parameter write
1	1	0	Command

This LCM is set to be controlled by 8080 family MPU

### 3.5 POWER SUPPLY CIRCUIT

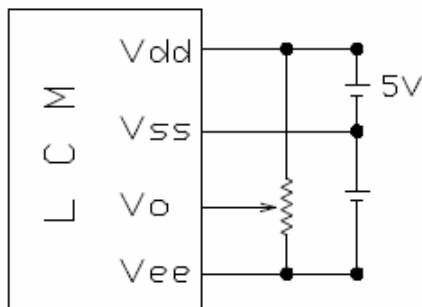

NEGATIVE VOLTAGE  
NOT BUILD IN

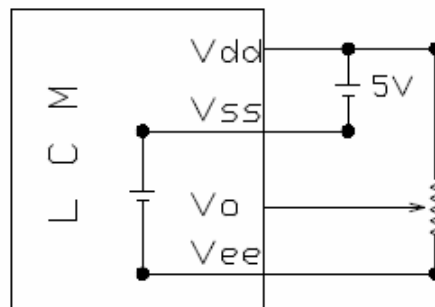

NEGATIVE VOLTAGE  
BUILD IN

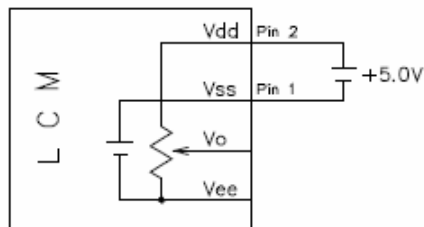

Negative Voltage and Temperature  
Compensation built in

RECOMMENDED  $V_R$  : 10K ohm ~ 20K ohm

Product No.	TSR4855 / TSR6855	REV. A

Page	11 / 30
------	---------

### 3.6 CHARACTER GENERATOR ROM MAP

		Character code bits 0 to 3																
		0	1	2	3	4	5	6	7	8	9	A	B	C	D	E	F	
Character code bits 4 to 7	2		!	"	#	\$	%	&	'	(	)	*	+	,	-	.	/	
	3	0	1	2	3	4	5	6	7	8	9	A	B	C	D	E	F	
	4	G	H	I	J	K	L	M	N	O	P	Q	R	S	T	U	V	W
	5	X	Y	Z	[	\	]	^	_	`	{		}	~				
	6	a	b	c	d	e	f	g	h	i	j	k	l	m	n	o		
	7	p	q	r	s	t	u	v	w	x	y	z	{		}	~		
	A																	
	B																	
	C																	
	D																	
	1																	

Product No.	TSR4855 / TSR6855	REV. A

Page	12 / 30
------	---------

### 3.7 Character Codes

The following figures shows the character codes and the codes allocated to CG RAM. All codes can be used by the CG RAM if not using the internal ROM.

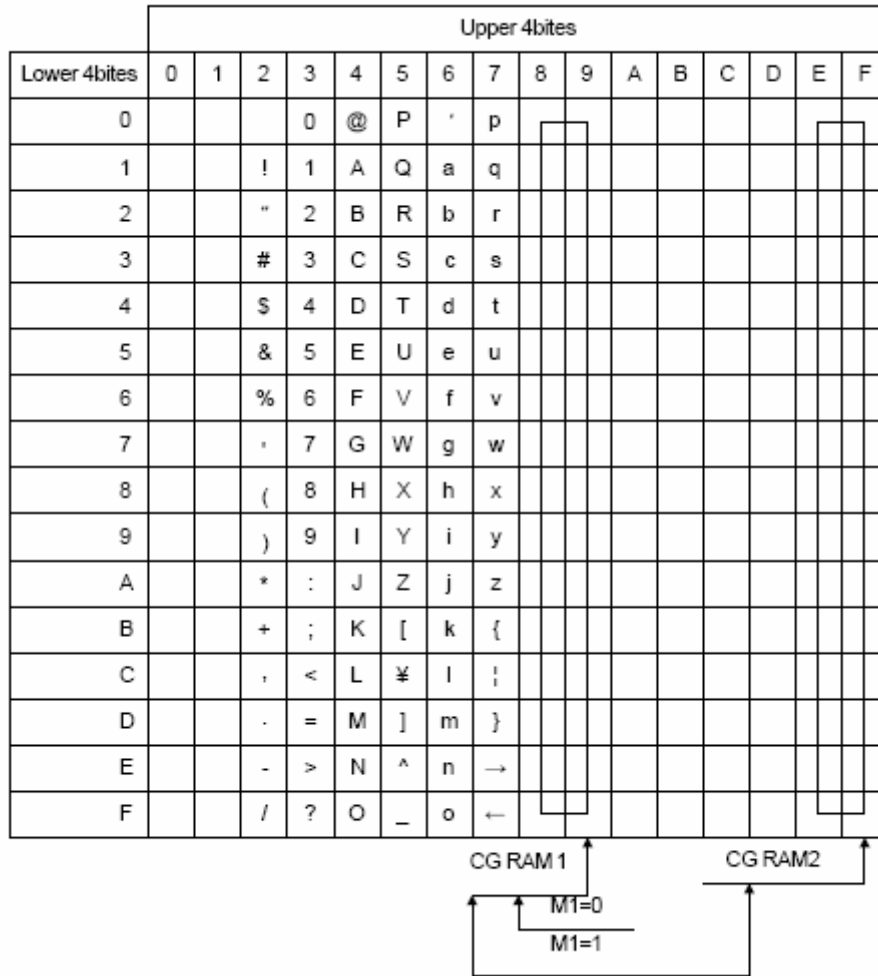

### 3.8 TIMING CHARECTERISTICS

#### 3.8.1 8080 Family Interface timing

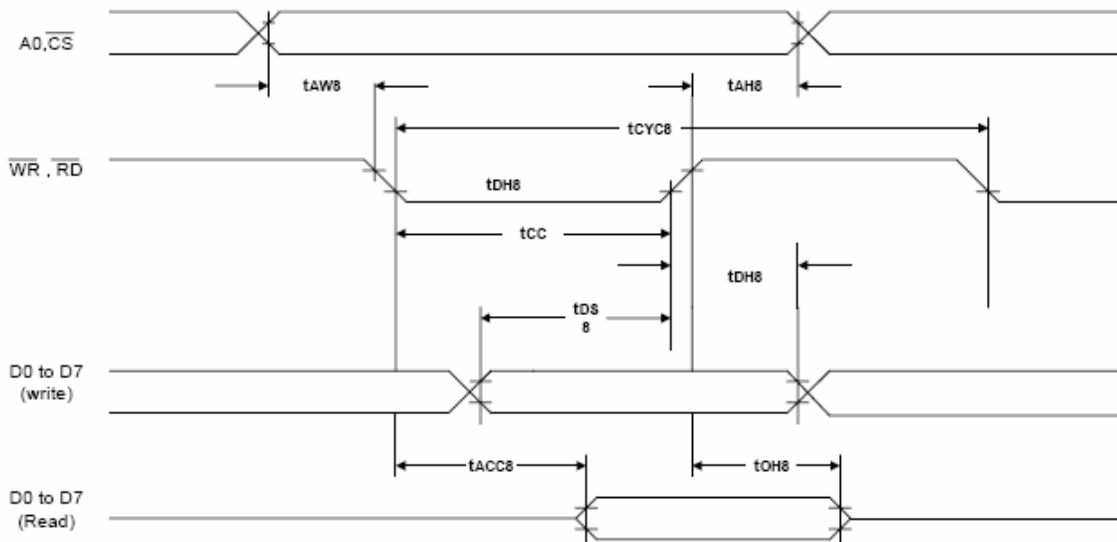

T<sub>a</sub> = -20 to 75°C

Signal	Symbol	Parameter	V <sub>DD</sub> = 4.5 to 5.5V		V <sub>DD</sub> = 2.7 to 4.5V		Unit	Condition
			Min.	Max.	Min.	Max.		
A0, $\overline{CS}$	t <sub>AH8</sub>	Address hold time	10	—	10	—	ns	CL = 100pF
	t <sub>AW8</sub>	Address setup time	0	—	0	—	ns	
$\overline{WR}$ , $\overline{RD}$	t <sub>CYC8</sub>	System cycle time	note.	—	note.	—	ns	
	t <sub>CC</sub>	Strobe pulse width	120	—	150	—	ns	
D0 to D7	t <sub>DS8</sub>	Data setup time	120	—	120	—	ns	
	t <sub>DH8</sub>	Data hold time	5	—	5	—	ns	
	t <sub>ACC8</sub>	$\overline{RD}$ access time	—	50	—	80	ns	
	t <sub>OH8</sub>	Output disable time	10	50	10	55	ns	

**Note:** For memory control and system control commands:

$$t_{CYC8} = 2t_C + t_{CC} + t_{CEA} + 75 > t_{ACV} + 245$$

For all other commands:

$$t_{CYC8} = 4t_C + t_{CC} + 30$$

Product No.	TSR4855 / TSR6855	REV. A

Page	14 / 30
------	---------

## 4 OPTICAL SPECIFICATION

### 4.1 OPTICAL CHARACTERISTICS

#### 4.1.1 STN Type

Ta = 25 °C

Item	Symbol	Condition	Min	Typ	Max	Unit	Note
Viewing Angle	θ1	CR≥2		35		deg	1
	θ2	CR≥2		30		deg	1
	θ3	CR≥2		35		deg	2
	θ4	CR≥2		35		deg	2
Contrast Ratio	CR	Ta = 25 °C	4.0	5.5	8.0	-	3
Response Time	Tr	Ta = 25 °C	100	120	180	ms	4
	Tf	Ta = 25 °C	110	140	210		
Driving Method	Duty	1/240					
	Bias	1/13					
LCD Type	STN						
Viewing Direction	6 O'CLOCK						

Product No.	TSR4855 / TSR6855	REV. A

Page	15 / 30
------	---------

### 4.1.2 FSTN Type

Item	Symbol	Condition	Min	Typ	Max	Unit	Note
Viewing Angle	$\theta_1$	$CR \geq 2$		30		deg	1
	$\theta_2$	$CR \geq 2$		25		deg	1
	$\theta_3$	$CR \geq 2$		25		deg	2
	$\theta_4$	$CR \geq 2$		25		deg	2
Contrast Ratio	CR	$T_a = 25\text{ }^\circ\text{C}$	4.5	6.5	8.5	-	3
Response Time	Tr	$T_a = 25\text{ }^\circ\text{C}$	200	250	380	ms	4
	Tf	$T_a = 25\text{ }^\circ\text{C}$	120	150	230		
Driving Method	Duty	1/240					
	Bias	1/13					
LCD Type	FSTN						
Viewing Direction	6 O'CLOCK						

Note 1: definition of viewing angle  $\theta_1$  &  $\theta_2$

Note 2: definition of viewing angle  $\theta_3$  &  $\theta_4$

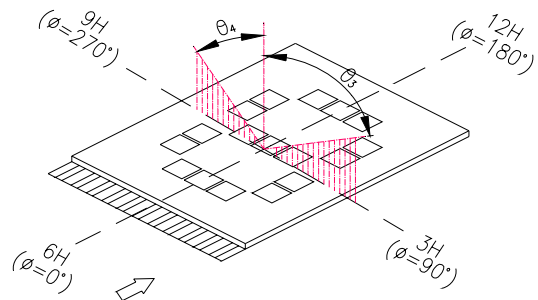
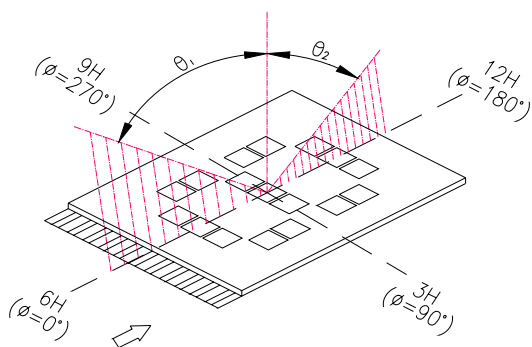

Product No.	TSR4855 / TSR6855	REV. A

Page	16 / 30
------	---------



Note 3: definition of contrast ratio (CR)

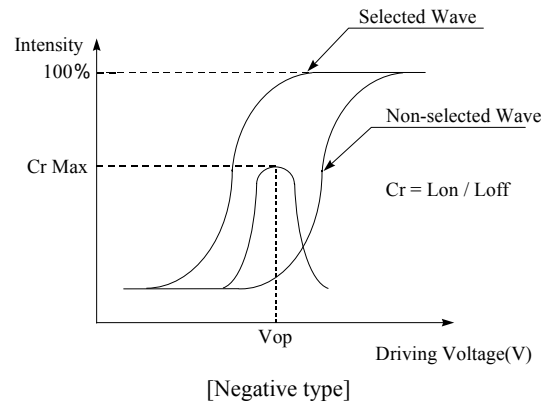
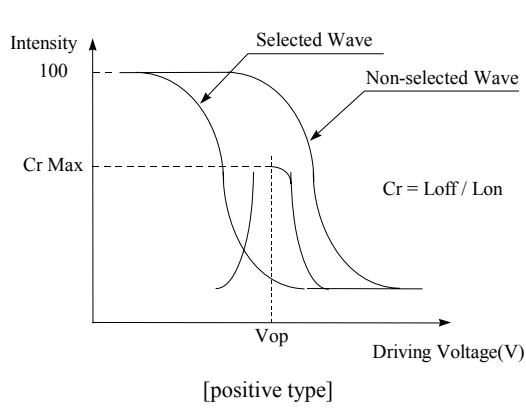

Note 4: definition of response time

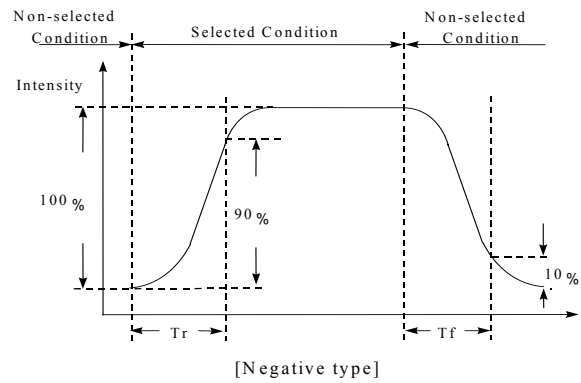
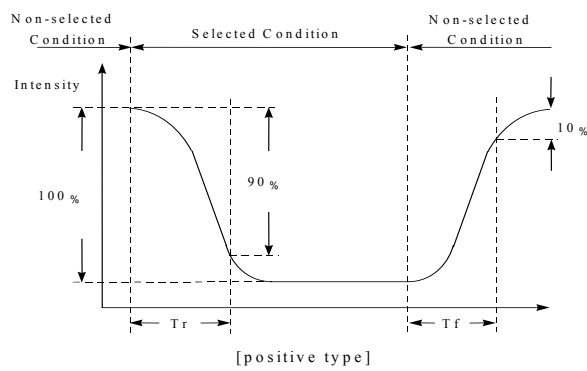

Product No.	TSR4855 / TSR6855	REV. A

Page	17 / 30
------	---------

## 5 Touch Panel Characteristics

Description	Specification	Condition
Transparency	$\geq 80\%$	ASTM D1003 (wavelength = 550nm)
Linearity	$\leq 1.5\%$	Material of pen: poly-acetal resin End shape: R0.8mm Test point: 100 points Test force: 80gf Note 1
Circuit Resistance X axis	300 ohm ~ 1100 ohm	At connector
Circuit Resistance Y axis	200 ohm ~ 500 ohm	At connector
Insulation Resistance	$\geq 20\text{M ohm}$	At DC 25V
Chattering time	$\leq 10\text{ms}$	Voltage: 3V Frequency: 5Hz
Activation force	5 gf ~ 80gf	End shape: R0.8mm Resistance must be equal or lower than 2k ohm between X and Y axis when testing voltage is 5V

### Durability Test

Description	Specification	Condition
Pen sliding durability	$\geq 100\text{k times}$	End shape: R0.8mm Load force: 250gf Writing speed: 300 mm/sec Material of pen: Poly-acetal resin Sliding length: 35mm
Knocking test	$\geq 1 \text{ million times}$	End shape: R0.8mm ( Hardness:50~60 degree) Load force: 250 gf Frequency: 5 Hz ( By silicon rubber tapping at same points )
Hardness of surface	3H	JIS K 5400

Product No.	TSR4855 / TSR6855	REV. A

Page	18 / 30
------	---------

Note 1: Measurement condition of Linearity

Linearity Definition

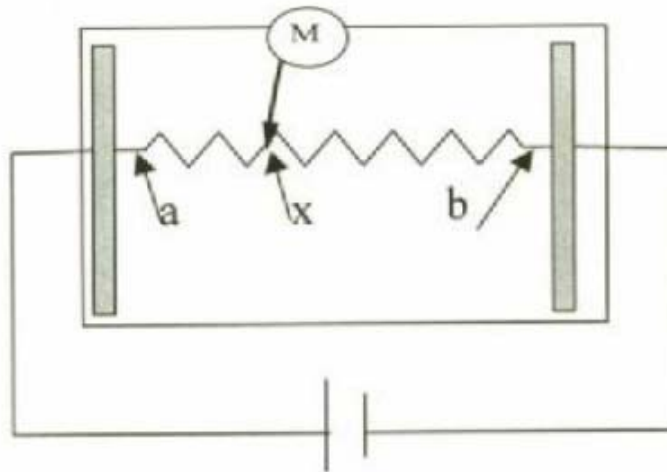

- Va : maximum voltage in the active area of touch panel
- Vb: minimum voltage in the active area of touch panel
- X : random measuring point
- Vxm: Actual voltage of Lx point
- Vxi : Theoretical voltage of Lx point

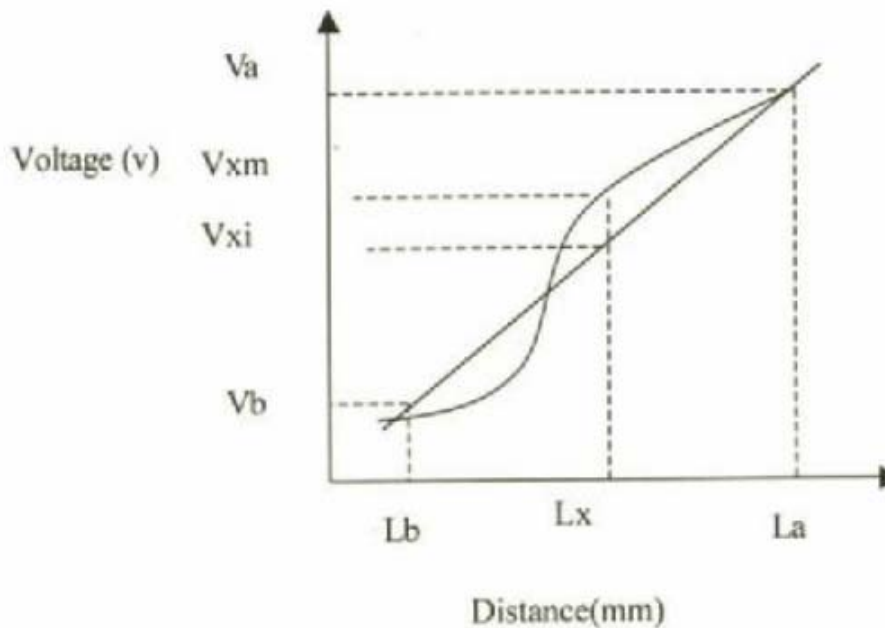

$$\text{Linearity} : [ | Vxi - Vxm | / (Va - Vb) ] * 100\%$$

Product No.	TSR4855 / TSR6855	REV. A

Page	19 / 30
------	---------

## 6 BACKLIGHT SPECIFICATION

### 6.1 BACKLIGHT CHARACTERISTICS

#### 6.1.1 LED backlight

Ta=25°C

Item	Symbol	Condition	Min	Typ	Max	Unit	Note
Input Voltage	V <sub>LED</sub>		--	5	--	V	
Input Current	I <sub>LED</sub>		--	120	--	mA	
Average Brightness Ta=25°C IL=5mA Backlight only	Test when connecting after 3min. (max contrast) White LED		150	180	--	cd/m <sup>2</sup>	2
Brightness Uniformity		I <sub>LED</sub> = 120mA	80	--	--	%	3
Life time	I <sub>LED</sub> = 120mA Humidity: 30%RH ~ 85%RH		--	40000	--	hrs	4
Colour	White						
Operating Temp	Humidity: 30%RH ~85%RH		-20	-	70	°C	
Storage Temp	Humidity: 30%RH ~85%RH		-30	-	80	°C	
Limit resistor (R2)	Ta=25°C		-	N/A		Ohm	1

Product No.	TSR4855 / TSR6855	REV. A

Page	20 / 30
------	---------

### 6.1.2 CCFL Backlight

Ta=25°C

Item	Symbol	Condition	Min	Typ	Max	Unit	Note
Starting Voltage		Ta=0°C	--	--	680	Vrms	
Lamp Voltage		Ta=25°C	--	296	--	Vrms	
Lamp Current		Ta=25°C	4.5	5.0	5.5	mA	
Oscillation frequency		Ta=25°C	50.0	55.0	60.0	Khz	
Average Brightness Ta=25°C IL=5mA Backlight only		Test when connecting after 3min. (max contrast)	-	650	-	cd/m <sup>2</sup>	2
Life time		Ta=25°C IL = 5mA Humidity: 30%RH ~ 85%RH	--	17000	--	hrs	4
Operating Temp		Humidity: 30%RH ~85%RH	0	-	60	°C	
Storage Temp		Humidity: 30%RH ~85%RH	-30	-	80	°C	

Note:

1. R2 resistor is built in B/L
2. Average brightness of 3 points when B/L is used at the beginning
3. Brightness uniformity = (Min/Max) x 100%
4. Half of the original average brightness

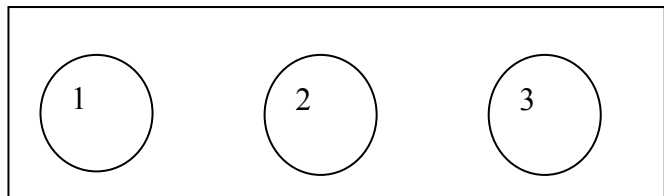

## 7 LABELLING & MARKING

DENSITRON  
TSR4855 or TSR6855  
Taiwan YYMM

Product No.	TSR4855 / TSR6855	REV. A

Page	21 / 30
------	---------

## 8 QUALITY ASSURANCE SPECIFICATION

### 8.1 CONFORMITY

---

The performance, function and reliability of the shipped products conform to the Product Specification.

### 8.2 DELIVERY ASSURANCE

---

#### 8.2.1 Delivery inspection standards

- IPC-AA610 class 2 electronic assemblies standard

#### 8.2.2 Zone definition

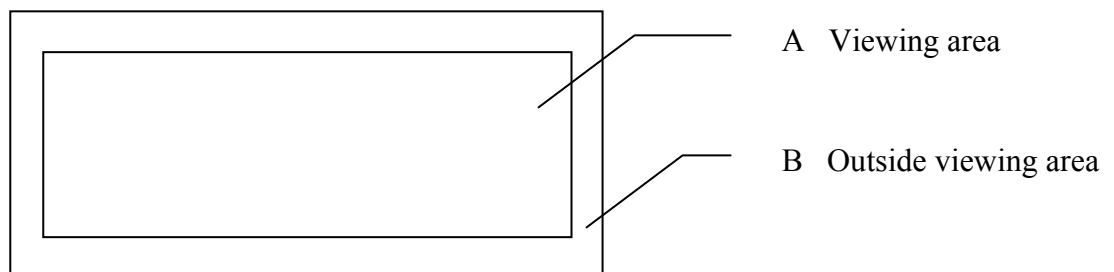

Product No.	TSR4855 / TSR6855	REV. A

Page	22 / 30
------	---------

### 8.2.3 Visual inspection

- Inspect under 2x20W or 40W fluorescent lamp (approximately 3000 lux) leaving 25 to 30 cm between the module and the lamp and 30 cm between the module and the eye (measuring position).
- Appearance is inspected at the best contrast voltage (best contrast is adjusted considering clearness and crosstalk on screen).
- Inspect the module at 45° right and left, top and bottom.
- Use the optimum viewing angle during the contrast inspection.

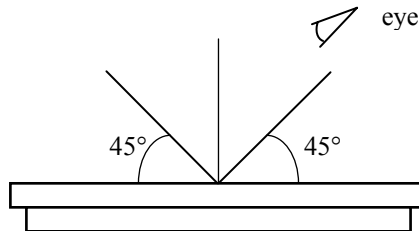

Product No.	TSR4855 / TSR6855	REV. A

Page	23 / 30
------	---------

### 8.2.3.1 Standard of appearance inspection

Units: mm

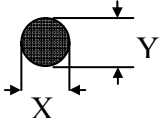
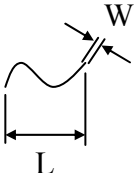
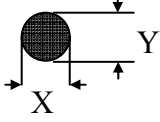
Class	Item	Criteria																															
Minor	Packing & Label	Outside & inside package   Presence of product no., lot no., quantity																															
Critical		Product must not be mixed with others and quantity must not be different from that indicated on the label																															
Major	Dimension	Product dimensions must be according to specification and drawing																															
Major	Electrical	Product electrical characteristics must be according to specification																															
Critical	LCD Display	Missing lines or wrong patterns on LCD display are not allowed																															
Minor	Black spot, white spot, dust	<p>Round type: as per following drawing  <math>\varnothing = (X+Y)/2</math></p>  <table border="1" style="margin-left: auto; margin-right: auto;"> <thead> <tr> <th colspan="3">Acceptable quantity</th> </tr> <tr> <th>Size</th> <th>Zone A</th> <th>Zone B</th> </tr> </thead> <tbody> <tr> <td><math>\varnothing &lt; 0.2</math></td> <td>Any number</td> <td rowspan="3">Any number</td> </tr> <tr> <td><math>0.2 &lt; \varnothing &lt; 0.25</math></td> <td>3</td> </tr> <tr> <td><math>0.25 &lt; \varnothing</math></td> <td>0</td> </tr> </tbody> </table> <p>Line type: as per following drawing</p>  <table border="1" style="margin-left: auto; margin-right: auto;"> <thead> <tr> <th colspan="4">Acceptable quantity</th> </tr> <tr> <th>Length</th> <th>Width</th> <th>Zone A</th> <th>Zone B</th> </tr> </thead> <tbody> <tr> <td>--</td> <td><math>W \leq 0.03</math></td> <td>Any number</td> <td rowspan="3">Any number</td> </tr> <tr> <td><math>L \leq 3</math></td> <td><math>0.03 &lt; W \leq 0.05</math></td> <td>2</td> </tr> <tr> <td>--</td> <td><math>0.05 &lt; W</math></td> <td>As round type</td> </tr> </tbody> </table> <p style="text-align: center;">Total acceptable quantity: 5</p>	Acceptable quantity			Size	Zone A	Zone B	$\varnothing < 0.2$	Any number	Any number	$0.2 < \varnothing < 0.25$	3	$0.25 < \varnothing$	0	Acceptable quantity				Length	Width	Zone A	Zone B	--	$W \leq 0.03$	Any number	Any number	$L \leq 3$	$0.03 < W \leq 0.05$	2	--	$0.05 < W$	As round type
Acceptable quantity																																	
Size	Zone A	Zone B																															
$\varnothing < 0.2$	Any number	Any number																															
$0.2 < \varnothing < 0.25$	3																																
$0.25 < \varnothing$	0																																
Acceptable quantity																																	
Length	Width	Zone A	Zone B																														
--	$W \leq 0.03$	Any number	Any number																														
$L \leq 3$	$0.03 < W \leq 0.05$	2																															
--	$0.05 < W$	As round type																															
Minor	Polariser scratch	Scratch on protective film is permitted Scratch on polariser: same as No. 1																															
Minor	Polariser bubble	<p><math>\varnothing = (X+Y)/2</math></p>  <table border="1" style="margin-left: auto; margin-right: auto;"> <thead> <tr> <th colspan="3">Acceptable quantity</th> </tr> <tr> <th>Size</th> <th>Zone A</th> <th>Zone B</th> </tr> </thead> <tbody> <tr> <td><math>\varnothing &lt; 0.2</math></td> <td>Any number</td> <td rowspan="4">Any number</td> </tr> <tr> <td><math>0.2 &lt; \varnothing &lt; 0.5</math></td> <td>3</td> </tr> <tr> <td><math>0.5 &lt; \varnothing &lt; 1.0</math></td> <td>1</td> </tr> <tr> <td><math>1.0 &lt; \varnothing</math></td> <td>0</td> </tr> </tbody> </table> <p style="text-align: center;">Total acceptable quantity: 4</p>	Acceptable quantity			Size	Zone A	Zone B	$\varnothing < 0.2$	Any number	Any number	$0.2 < \varnothing < 0.5$	3	$0.5 < \varnothing < 1.0$	1	$1.0 < \varnothing$	0																
Acceptable quantity																																	
Size	Zone A	Zone B																															
$\varnothing < 0.2$	Any number	Any number																															
$0.2 < \varnothing < 0.5$	3																																
$0.5 < \varnothing < 1.0$	1																																
$1.0 < \varnothing$	0																																

Product No.	TSR4855 / TSR6855	REV. A

Page	24 / 30
------	---------

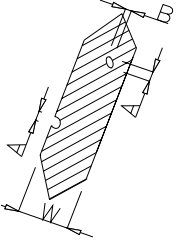
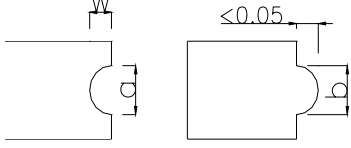
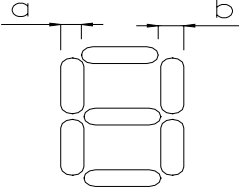
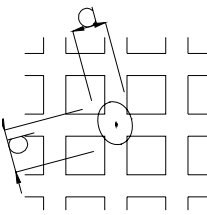

Class	Item	Criteria																												
Minor	Segment deformation	<p>1.a. Pin hole on segmented display</p> <p>W: segment width  <math>\varnothing = (A+B)/2</math></p>  <table border="1" style="margin-left: auto; margin-right: auto;"> <thead> <tr> <th colspan="2">Acceptable quantity</th> </tr> <tr> <th>Width</th> <th><math>\varnothing</math></th> </tr> </thead> <tbody> <tr> <td><math>W \leq 0.4</math></td> <td><math>\varnothing \leq 0.2</math> and <math>\varnothing \leq 1/2W</math></td> </tr> <tr> <td><math>W &gt; 0.4</math></td> <td><math>\varnothing \leq 0.25</math> and <math>\varnothing \leq 1/3W</math></td> </tr> </tbody> </table> <p>Total acceptable quantity: 1 defect per segment  Pin holes with <math>\varnothing</math> under 0.10 mm are acceptable</p>	Acceptable quantity		Width	$\varnothing$	$W \leq 0.4$	$\varnothing \leq 0.2$ and $\varnothing \leq 1/2W$	$W > 0.4$	$\varnothing \leq 0.25$ and $\varnothing \leq 1/3W$																				
Acceptable quantity																														
Width	$\varnothing$																													
$W \leq 0.4$	$\varnothing \leq 0.2$ and $\varnothing \leq 1/2W$																													
$W > 0.4$	$\varnothing \leq 0.25$ and $\varnothing \leq 1/3W$																													
Minor	Segment deformation	<p>1b. Pin hole on dot matrix display</p>  <table border="1" style="margin-left: auto; margin-right: auto;"> <thead> <tr> <th colspan="2">Acceptable quantity</th> </tr> <tr> <th>Size</th> <th></th> </tr> </thead> <tbody> <tr> <td><math>a, b &lt; 0.1</math></td> <td>Any number</td> </tr> <tr> <td><math>(a+b)/2 \leq 0.1</math></td> <td>Any number</td> </tr> <tr> <td><math>0.5 &lt; \varnothing &lt; 1.0</math></td> <td>3</td> </tr> </tbody> </table> <p>Total acceptable quantity: 7</p> <p>2. Segments / dots with different width</p>  <table border="1" style="margin-left: auto; margin-right: auto;"> <thead> <tr> <th colspan="2">Acceptable</th> </tr> </thead> <tbody> <tr> <td><math>a \geq b</math></td> <td><math>a/b \leq 4/3</math></td> </tr> <tr> <td><math>a &lt; b</math></td> <td><math>a/b &gt; 4/3</math></td> </tr> </tbody> </table> <p>3. Alignment layer defect</p> <p><math>\varnothing = (a+b)/2</math></p>  <table border="1" style="margin-left: auto; margin-right: auto;"> <thead> <tr> <th colspan="2">Acceptable quantity</th> </tr> <tr> <th>Size</th> <th></th> </tr> </thead> <tbody> <tr> <td><math>\varnothing \leq 0.4</math></td> <td>Any number</td> </tr> <tr> <td><math>0.4 &lt; \varnothing \leq 1.0</math></td> <td>5</td> </tr> <tr> <td><math>1.0 &lt; \varnothing \leq 1.5</math></td> <td>3</td> </tr> <tr> <td><math>1.5 &lt; \varnothing \leq 2.0</math></td> <td>2</td> </tr> </tbody> </table> <p>Total acceptable quantity: 7</p>	Acceptable quantity		Size		$a, b < 0.1$	Any number	$(a+b)/2 \leq 0.1$	Any number	$0.5 < \varnothing < 1.0$	3	Acceptable		$a \geq b$	$a/b \leq 4/3$	$a < b$	$a/b > 4/3$	Acceptable quantity		Size		$\varnothing \leq 0.4$	Any number	$0.4 < \varnothing \leq 1.0$	5	$1.0 < \varnothing \leq 1.5$	3	$1.5 < \varnothing \leq 2.0$	2
Acceptable quantity																														
Size																														
$a, b < 0.1$	Any number																													
$(a+b)/2 \leq 0.1$	Any number																													
$0.5 < \varnothing < 1.0$	3																													
Acceptable																														
$a \geq b$	$a/b \leq 4/3$																													
$a < b$	$a/b > 4/3$																													
Acceptable quantity																														
Size																														
$\varnothing \leq 0.4$	Any number																													
$0.4 < \varnothing \leq 1.0$	5																													
$1.0 < \varnothing \leq 1.5$	3																													
$1.5 < \varnothing \leq 2.0$	2																													
Minor	Colour uniformity	Level of sample for approval set as limit sample																												
Critical	Backlight	The backlight colour should correspond to the product specification																												
Critical		Flashing and or unlit backlight is not allowed																												
Minor		Dust larger than 0.25 mm is not allowed																												
Major	COB	Exposed wire bond pad is not allowed																												
Major		Insufficient covering with resin is not allowed (wire bond line exposed)																												
Minor		Dust or bubble on the resin are not allowed																												

Product No.	TSR4855 / TSR6855	REV. A

Page	25 / 30
------	---------

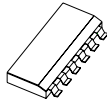
Class	Item	Criteria
Major	PCB 	No unmelted solder paste should be present on PCB
Critical		Cold solder joints, missing solder connections, or oxidation are not allowed
Minor		No residue or solder balls on PCB are allowed
Critical		Short circuits on components are not allowed

Product No.	TSR4855 / TSR6855	REV. A

Page	26 / 30
------	---------

## **8.3 DEALING WITH CUSTOMER COMPLAINTS**

---

### **8.3.1 Non-conforming analysis**

Purchaser should supply Densitron with detailed data of non-conforming sample.

After accepting it, Densitron should complete the analysis in two weeks from receiving the sample.

If the analysis cannot be completed on time, Densitron must inform the purchaser.

### **8.3.2 Handling of non-conforming displays**

If any non-conforming displays are found during customer acceptance inspection which Densitron is clearly responsible for, return them to Densitron.

Both Densitron and customer should analyse the reason and discuss the handling of non-conforming displays when the reason is not clear.

Equally, both sides should discuss and come to agreement for issues pertaining to modification of Densitron quality assurance standard.

Product No.	TSR4855 / TSR6855	REV. A

Page	27 / 30
------	---------

## 9 RELIABILITY SPECIFICATION

### 9.1 RELIABILITY TESTS

#### Standard Temp

Test Item	Test Condition	Evaluation and assessment
High Temperature Operation	50°C ±2°C for 240 hours	No abnormalities in function* and appearance
Low Temperature Operation	0°C ±2°C for 240 hours	No abnormalities in function* and appearance
Thermal Shock Storage	-20°C (30 min) ->25°C (5 min) - >70°C (30 min) - >25°C (5 min) 5 cycles	No abnormalities in function* and appearance
Vibration	10Hz ~ 55Hz 0.3mm / 1 Octave 55Hz ~ 500Hz 3g / 1 Octave 20 cycle / per axis	No abnormalities in function* and appearance

#### Wide Temp

Test Item	Test Condition	Evaluation and assessment
High Temperature Operation	70°C ±2°C for 240 hours	No abnormalities in function* and appearance
Low Temperature Operation	-20°C ±2°C for 240 hours	No abnormalities in function* and appearance
Thermal Shock Storage	-30°C (30 min) ->25°C (5 min) - >80°C (30 min) - >25°C (5 min) 5 cycles	No abnormalities in function* and appearance
Vibration	10Hz ~ 55Hz 0.3mm / 1 Octave 55Hz ~ 500Hz 3g / 1 Octave 20 cycle / per axis	No abnormalities in function* and appearance

\* Current consumption 3 times initial value

\* Contrast > ½ initial value

### 9.2 LIFE TIME

Item	Description
1	Function, performance, appearance, etc. shall be free from remarkable deterioration within 50,000 hours under ordinary operating and storage conditions of room temperature (25±10 °C), normal humidity (45±20% RH), and in area not exposed to direct sunlight.

Product No.	TSR4855 / TSR6855	REV. A
-------------	-------------------	--------

Page	28 / 30
------	---------

## 10 PART NUMBER DESCRIPTIONS FOR AVAILABLE OPTIONS

### TSR①855②③240G320④⑤⑥

- ① 4 = LED backlight version  
6 = CCFL backlight version
- ② **POLARIZER TYPE**  
B = Transflective: light background  
E = Transmissive: dark background
- ③ **BACKLIGHT COLOUR**  
W = White or left blank for CCFL type
- ④ **FLUID TYPE AND POWER SUPPLY**  
W = Wide Temperature Range; on-board negative supply voltage generator  
H = Wide Temperature Range  
S = Standard Temperature Range: on board negative supply voltage generator  
D = Standard Temperature Range; negative supply voltage required
- ⑤ **TEMPERATURE COMPENSATION**  
C = with on board temperature compensation circuitry  
N = **No** on board temperature compensation and NTN Fluid
- ⑥ **FLUID TYPE**  
F = FSTN  
B = STN ( Blue Mode )

Product No.	TSR4855 / TSR6855	REV. A

Page	29 / 30
------	---------

## 11 HANDLING PRECAUTIONS

### *Safety*

If the LCD panel breaks, be careful not to get the liquid crystal fluid in your mouth or in your eyes. If the liquid crystal touches your skin or clothes, wash it off immediately using soap and plenty of water.

### *Mounting and Design*

Place a transparent plate (e.g. acrylic, polycarbonate or glass) on the display surface to protect the display from external pressure. Leave a small gap between the transparent plate and the display surface.

When assembling with a zebra connector, clean the surface of the pads with alcohol and keep the surrounding air very clean.

Design the system so that no input signal is given unless the power supply voltage is applied.

### *Caution during LCD cleaning*

Lightly wipe the display surface with a soft cloth soaked with Isopropyl alcohol, Ethyl alcohol or Trichlorotrifluoroethane.

Do not wipe the display surface with dry or hard materials that will damage the polariser surface.

Do not use aromatic solvents (toluene and xylene), or ketonic solvents (ketone and acetone).

### *Caution against static charge*

As the display uses C-MOS LSI drivers, connect any unused input terminal to VDD or VSS. Do not input any signals before power is turned on.

Also, ground your body, work/assembly table and assembly equipment to protect against static electricity.

### *Packaging*

Displays use LCD elements, and must be treated as such. Avoid strong shock and drop from a height.

To prevent displays from degradation, do not operate or store them exposed directly to sunshine or high temperature/humidity.

### *Caution during operation*

It is indispensable to drive the display within the specified voltage limit since excessive voltage shortens its life.

Direct current causes an electrochemical reaction with remarkable deterioration of the display quality.

Give careful consideration to prevent direct current during ON/OFF timing and during operation.

Response time is extremely delayed at temperatures lower than the operating temperature range while, at high temperatures, displays become dark. However, this phenomenon is reversible and does not mean a malfunction or a display that has been permanently damaged.

If the display area is pushed on hard during operation, some graphics will be abnormally displayed but returns to a normal condition after turning off the display once.

Even a small amount of condensation on the contact pads (terminals) can cause an electro-chemical reaction which causes missing rows and columns. Give careful attention to avoid condensation.

### *Storage*

Store the display in a dark place where the temperature is  $25^{\circ}\text{C} \pm 10^{\circ}\text{C}$  and the humidity below 50%RH.

Store the display in a clean environment, free from dust, organic solvents and corrosive gases.

Do not crash, shake or jolt the display (including accessories).

Product No.	TSR4855 / TSR6855	REV. A

Page	30 / 30
------	---------