

# LIQUID CRYSTAL DISPLAY MODULE

## Product Specification

<b>CUSTOMER</b>	<b>Standard</b>
<b>CUSTOMER PART NUMBER</b>	
<b>PRODUCT NUMBER</b>	<b>DET035HVNMRSSS-1A</b>

Product Mgr	Design Eng
<b>Bruno Recaldini</b>	<b>Sunny</b>
Date: 13-Mar-14	Date: 13-Mar-14

## TABLE OF CONTENTS

<b>1</b>	<b>MAIN FEATURES</b> .....	<b>4</b>
<b>2</b>	<b>MECHANICAL SPECIFICATION</b> .....	<b>5</b>
2.1	MECHANICAL CHARACTERISTICS.....	5
2.2	MECHANICAL DRAWING.....	6
<b>3</b>	<b>ELECTRICAL SPECIFICATION</b> .....	<b>7</b>
3.1	ABSOLUTE MAXIMUM RATINGS.....	7
3.2	DC ELECTRICAL CHARACTERISTICS .....	7
3.3	INTERFACE PIN ASSIGNMENT .....	8
3.4	TIMING CHARACTERISTICS .....	10
<b>4</b>	<b>OPTICAL SPECIFICATION</b> .....	<b>16</b>
4.1	OPTICAL CHARACTERISTICS .....	16
<b>5</b>	<b>BACKLIGHT SPECIFICATION</b> .....	<b>18</b>
5.1	LED DRIVING CONDITIONS .....	18
5.2	LED CIRCUIT .....	18
<b>6</b>	<b>TOUCH PANEL SPECIFICATION</b> .....	<b>19</b>
6.1	ELECTRICAL CHARACTERISTICS.....	19
6.2	MECHANICAL CHARACTERISTICS.....	19
<b>7</b>	<b>QUALITY ASSURANCE SPECIFICATION</b> .....	<b>20</b>
7.1	DELIVERY INSPECTION STANDARDS .....	20
7.2	DEALING WITH CUSTOMER COMPLAINTS.....	24
<b>8</b>	<b>RELIABILITY SPECIFICATION</b> .....	<b>25</b>
8.1	RELIABILITY TESTS.....	25
<b>9</b>	<b>HANDLING PRECAUTIONS</b> .....	<b>26</b>

**REVISION RECORD**

<b>Rev.</b>	<b>Date</b>	<b>Page</b>	<b>Chapt.</b>	<b>Comment</b>	<b>ECN no.</b>
1.0	13-Mar-14			Initial Release	

## 1 MAIN FEATURES

ITEM	CONTENTS
Screen Size	3.5" Diagonal
Display Format	320 x RGB x 480 Dots
N° of Colour	262K
Active Area	48.96 mm (H) x 73.44 mm (V)
LCD Type	TFT
Mode	IPS Transmissive / Normally Black
Viewing Direction	Full view
Interface	8/9/16/18-bit DBI Type B (CPU) interface 6/16/18-bit RGB interface; 3/4-lines serial interface
Driver IC	ILI9486L or equivalent
Backlight Type	LED
Touch Panel	4 wire resistive
Operating Temperature	-20°C ~ +70°C
Storage Temperature	-30°C ~ +80°C
RoHS compliant	Yes

## 2 MECHANICAL SPECIFICATION

### 2.1 MECHANICAL CHARACTERISTICS

---

ITEM	CHARACTERISTIC	UNIT
Display Format	320 x RGB x 480 Dots	Dots
Overall Dimensions	54.58 mm (H) x 83.57 mm (V) x 3.59 mm (D)	mm
Active Area	48.96 mm (H) x 73.44 mm (V)	mm
pixel Pitch	51 (H) x 51 (V)	μm
Weight	30	g

## 2.2 MECHANICAL DRAWING

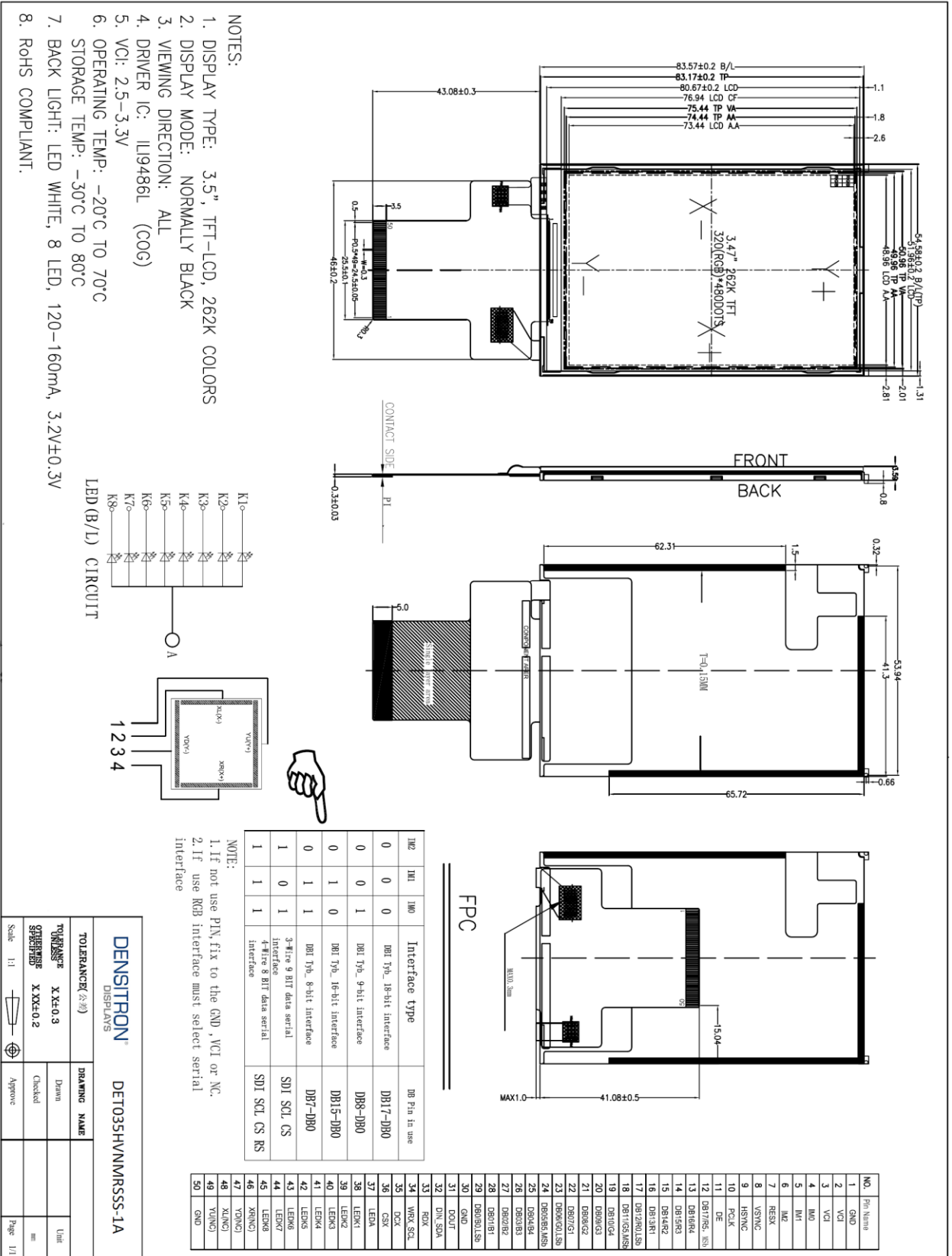

**DENSITRON**  
DISPLAYS

**DET035HVNMRSSS-1A**

TOLERANCE (公差)	DRAWING NAME	Unit
POSITION X.X±0.3	Drawn	
SIZE X.XX±0.2	Checked	mm
Scale 1:1	Approve	Page 1/1

### 3 ELECTRICAL SPECIFICATION

#### 3.1 ABSOLUTE MAXIMUM RATINGS

Item	Symbol	Condition	Min	Max	Unit	Note
Power Supply Voltage	VCI	Ta=25°C	-0.3	5.0	V	
Operating Temperature	TOP		-20	70	°C	1
Storage Temperature	TST		-30	80	°C	1,2,3

Note 1. 90 % RH Max for Ta<50 °C, and 60% RH for Ta≥50°C.

Note 2. In case of below 0°C, the response time of liquid crystal (LC) becomes slower and the colour of panel becomes darker than normal one. Level of retardation depends on temperature, because of LC's characteristic.

Note 3. Only operation is guaranteed at operating temperature. Contrast, response time, another display quality are evaluated at +25°C.

#### 3.2 DC ELECTRICAL CHARACTERISTICS

Item	Symbol	Condition	Min	Typ	Max	Unit	Note
Supply Voltage	VCI		2.8	3.3	3.6	V	
Input Voltage for Logic	VIH		0.8V <sub>CI</sub>	-	-	V	
	VIL		-	-	0.2 V <sub>CI</sub>	V	
Output Voltage for Logic	VOH		0.8 V <sub>CI</sub>	-	-	V	
	VOL		-	-	0.2 V <sub>CI</sub>	V	
Current Consumption	ICC		-	8		mA	1

Note 1: The specified power consumption is under the conditions of VCI=3.3V, FV=60Hz.

### 3.3 INTERFACE PIN ASSIGNMENT

#### 3.3.1 LCM PIN ASSIGNMENT

Recommended connector: AVX 04 6240 050 023 846+

NO.	SYMBOL	Description
1	GND	Ground.
2	VCI	Power supply voltage (VCI=2.8V-3.3V).
3	VCI	
4	IM0	
5	IM1	Interface selecting mode signal.
6	IM2	
7	RESET	Reset pin. Setting either pin low initializes the LSI. Must be reset after power is supplied.
8	VSYNC	Frame synchronizing signal for DPI I/F mode. If not used, please connect to GND.
9	HSYNC	Frame synchronizing signal for DPI I/F mode. If not used, please connect to GND.
10	PCLK	Pixel clock signal for DPI I/F mode. If not used, please connect to VCI.
11	DE	A DATA ENABLE signal for DPI I/F mode. If not used, please connect to GND.
12-29	DB17-DB0	Data bus PINS. 18-bit bi-directional data bus. 8-bit bus: use DB7-DB0 9-bit bus: use DB8-DB0 16-bit bus: use DB15-DB0 18-bit bus: use DB17-DB0 When Operation in MIPI DPI interface mode, it is an 18-bit bus RGB data bus. 6-bit bus: use DB5-DB0 16-bit bus: use DB15-DB0 18-bit bus: use DB17-DB0 Pins not used must be connected to GND.
30	GND	Ground.
31	DOUT	Serial data output pin in serial bus system interface. If not used, please open this pin.
32	DINI_SDA	Serial data input pin or input/output pin in serial bus system interface. The data is inputted on the rising edge of the SCL signal. If not used, please connect to GND.
33	RDX	DBI Type-B: Serves as a read signal and read data at the low level. If not used, please connect to VCI.



No	SYMBOL	Description
<b>34</b>	WRX_SCL	DBI Type-B: Serves as a write signal and write data at the low level. DBI Type-C: it servers as SCL (Serial Clock).If not use, please connect to GND.
<b>35</b>	DCX	Data / Command Selection pin. If not use, please connect to GND.
<b>36</b>	CSX	Chip select signal. Low: chip can be accessed; High: chip cannot be accessed. If not used, please connect to GND.
<b>37</b>	LEDA	Power supply for Backlight.
<b>38-45</b>	LEDK1-LEDK8	Power supply for Backlight.
<b>46</b>	XR	Touch panel right electrode
<b>47</b>	YD	Touch panel bottom electrode
<b>48</b>	XL	Touch panel left electrode
<b>49</b>	YU	Touch panel top electrode
<b>50</b>	GND	Ground.

### 3.4 TIMING CHARACTERISTICS

Please refer to Ilitech IC ILI9486L datasheet for more information

#### 3.4.1 (CPU) DBI Type B (18/16/9/8 Bits) Timing Characteristics

Item	Symbol	MIN	MAX	Unit	Remark	
Address setup time	RS(DCX)	tast	0	-	ns	
Address hold time (Write/Read)		taht	0	-	ns	
CSX "H" pulse width	CS(CSX)	tchw	0	-	Ns	
Chip select setup time (write)		tcs	15	-	ns	
Chip select setup time (Read ID)		trcs	45	-	ns	
Chip select setup time (Read FM)		trcsfm	355	-	ns	
Chip select Wait time (Write/Read)		tcsf	0	-	ns	
Write cycle Time		WR(WRX)	twc	50	-	ns
Write Control pulse H duration	twrh		15	-	ns	
Write Control pulse L duration	twrl		15	-	ns	
Read cycle (FM)	RD(RDX (FM))	trcfm	450	-	ns	
Read Control H duration (FM)		trdhfm	90	-	ns	
Read Control L duration (FM)		trdlfm	355	-	ns	
Read cycle (ID)	RD(RDX (ID))	trc	160	-	ns	
Read Control H duration		trdh	90	-	ns	
Read Control L duration		trdl	45	-	ns	
Write data setup time	BD[17:0], BD[8:0], BD[15:0], BD[7:0]	tdst	10	-	ns	For max CL=30pF
Write data hold time		tdht	10	-	ns	
Read access time		trat	-	40	ns	For min CL=8pF
Read access time (FM)		tratfm	-	340	ns	
Read output disable time		trod	20	80	ns	

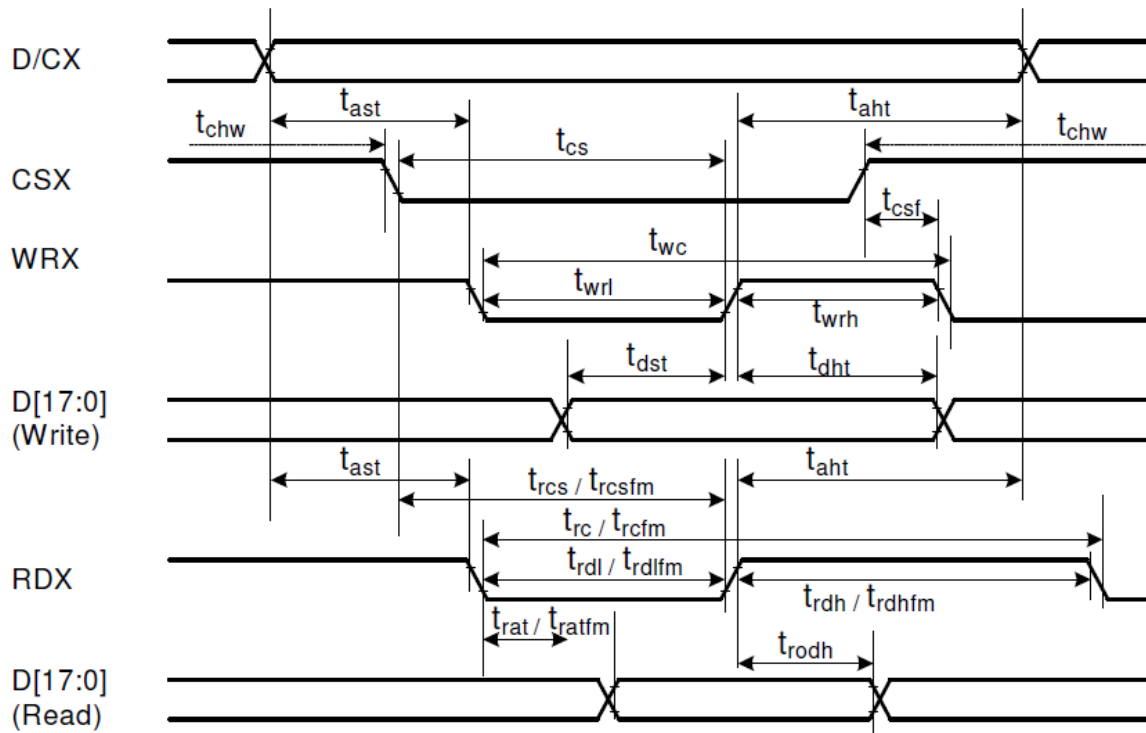

Note: (1) Ta=-20 to 70 °C, VCI= 3.3 V, DGND=0V

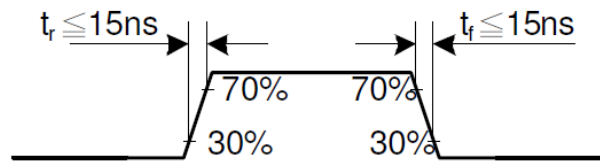

(2) Logic high and low levels are specified as 30% and 70% of VCI for input signals.

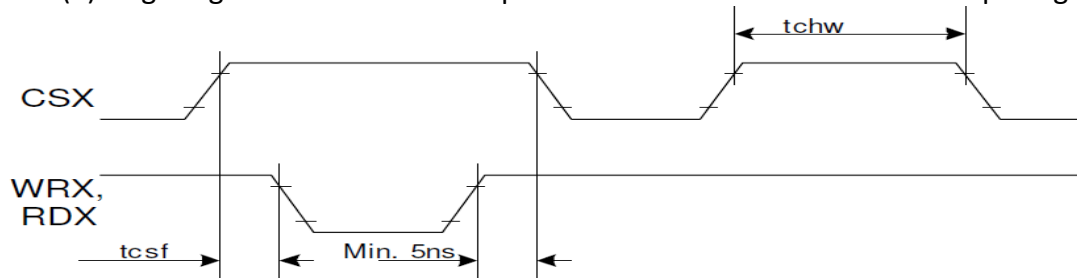

(3) Logic high and low levels are specified as 30% and 70% of VCI for input signals.

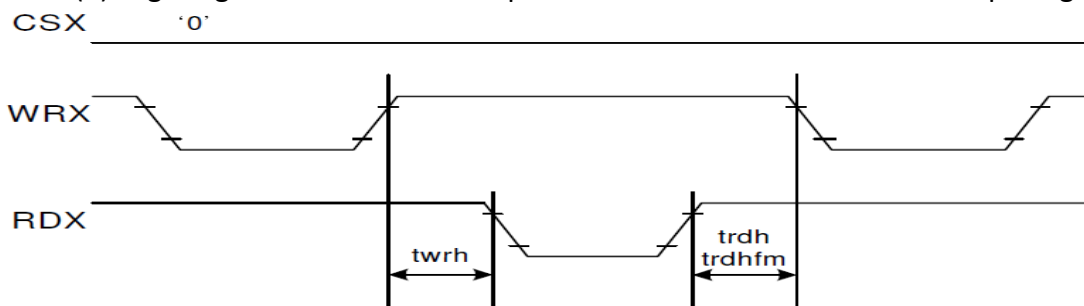

### 3.4.2 Parallel 18/16-bit RGB Interface Timing Characteristics

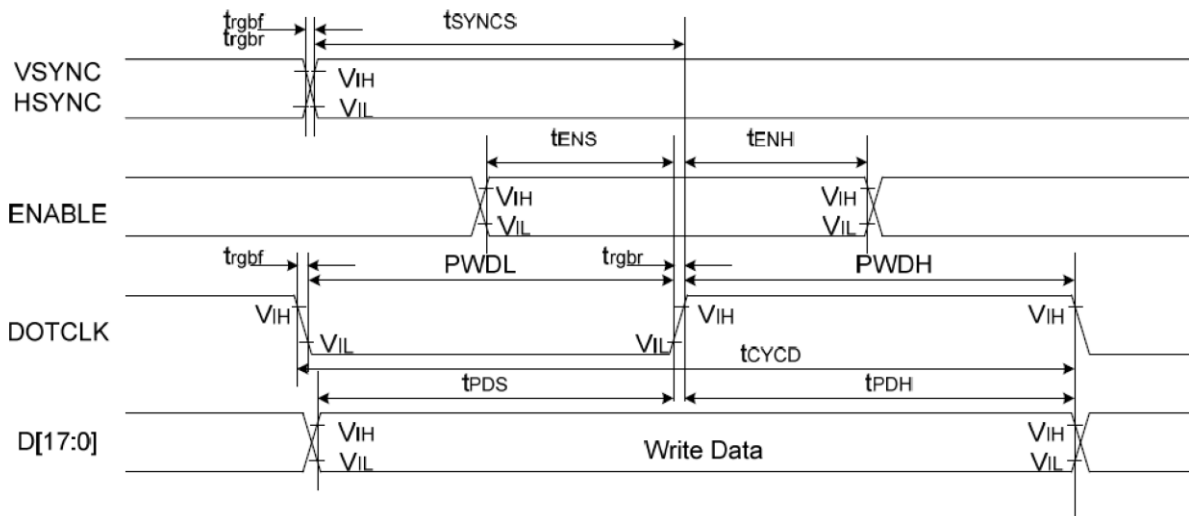

Signal	Symbol	Parameter	min	max	Unit	Description
VSYNC / HSYNC	$t_{SYNCS}$	VSYNC/HSYNC setup time	15	-	ns	18/16-bit bus RGB interface mode
	$t_{SYNCH}$	VSYNC/HSYNC hold time	15	-	ns	
ENABLE	$t_{ENS}$	ENABLE setup time	15	-	ns	
	$t_{ENH}$	ENABLE hold time	15	-	ns	
DB[17:0]	$t_{POS}$	Data setup time	15	-	ns	
	$t_{PDH}$	Data hold time	15	-	ns	
DOTCLK	PWDH	DOTCLK high-level period	15	-	ns	
	PWDL	DOTCLK low-level period	15	-	ns	
	$t_{CYCD}$	DOTCLK cycle time	66	-	ns	
	$t_{rgbr}, t_{rgbf}$	DOTCLK, HSYNC, VSYNC rise/fall time	-	15	ns	

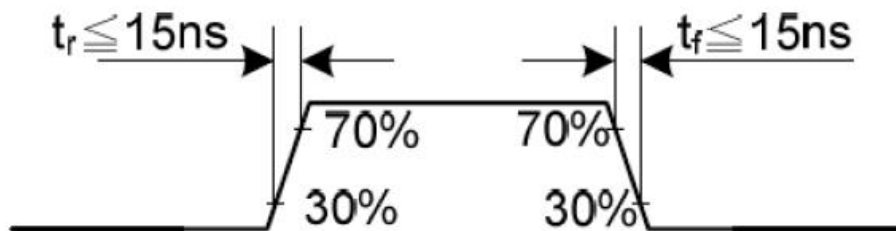

### 3.4.3 Display Serial Interface Timing Characteristics (3-line SPI system)

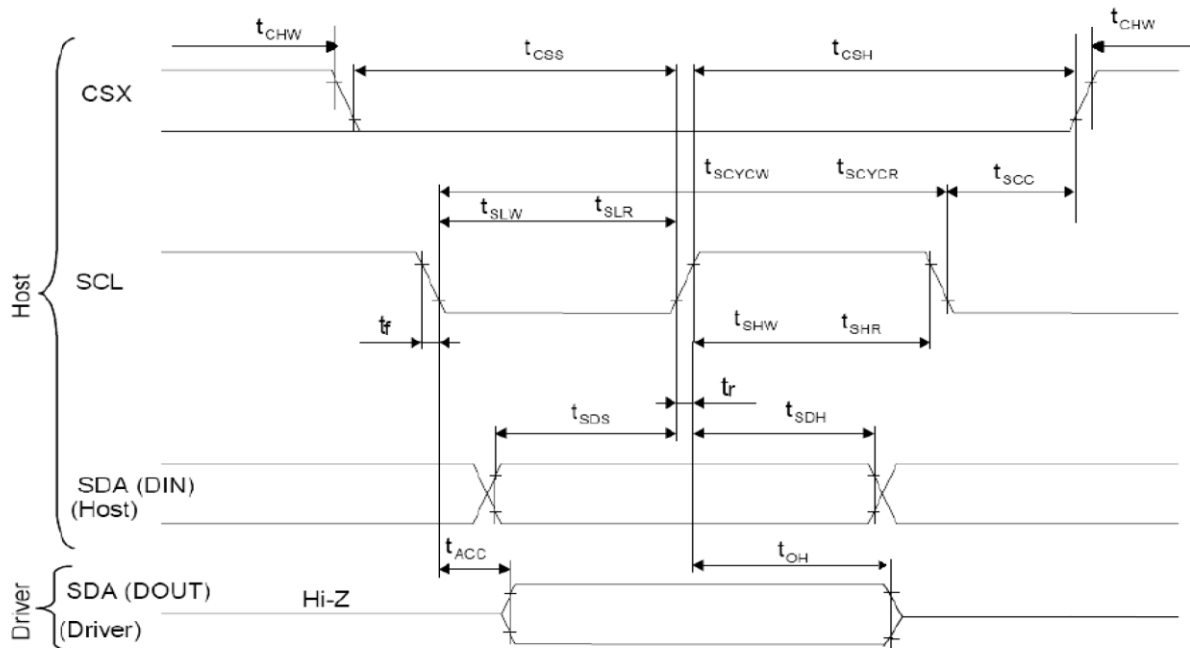

Signal	Symbol	Parameter	min	max	Unit	Description
SCL	$t_{scycw}$	Serial Clock Cycle (Write)	66	-	ns	
	$t_{shw}$	SCL "H" Pulse Width (Write)	15	-	ns	
	$t_{slw}$	SCL "L" Pulse Width (Write)	15	-	ns	
	$t_{scycr}$	Serial Clock Cycle (Read)	150	-	ns	
	$t_{shr}$	SCL "H" Pulse Width (Read)	60	-	ns	
	$t_{slr}$	SCL "L" Pulse Width (Read)	60	-	ns	
SDA / SDI (Input)	$t_{sdS}$	Data setup time (Write)	10	-	ns	
	$t_{sdH}$	Data hold time (Write)	10	-	ns	
SDA / SDO (Output)	$t_{acc}$	Access time (Read)	10	50	ns	
	$t_{oh}$	Output disable time (Read)	15	50	ns	
CSX	$t_{scc}$	SCL-CSX	15	-	ns	
	$t_{chW}$	CSX "H" Pulse Width	40	-	ns	
	$t_{cSS}$	CSX-SCL Time	60	-	ns	
	$t_{cSh}$		65	-	ns	

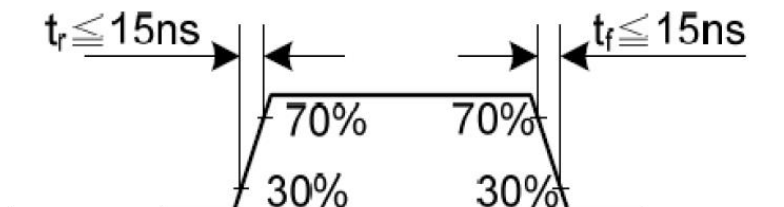

### 3.4.4 Display Serial Interface Timing Characteristics (4-line SPI system)

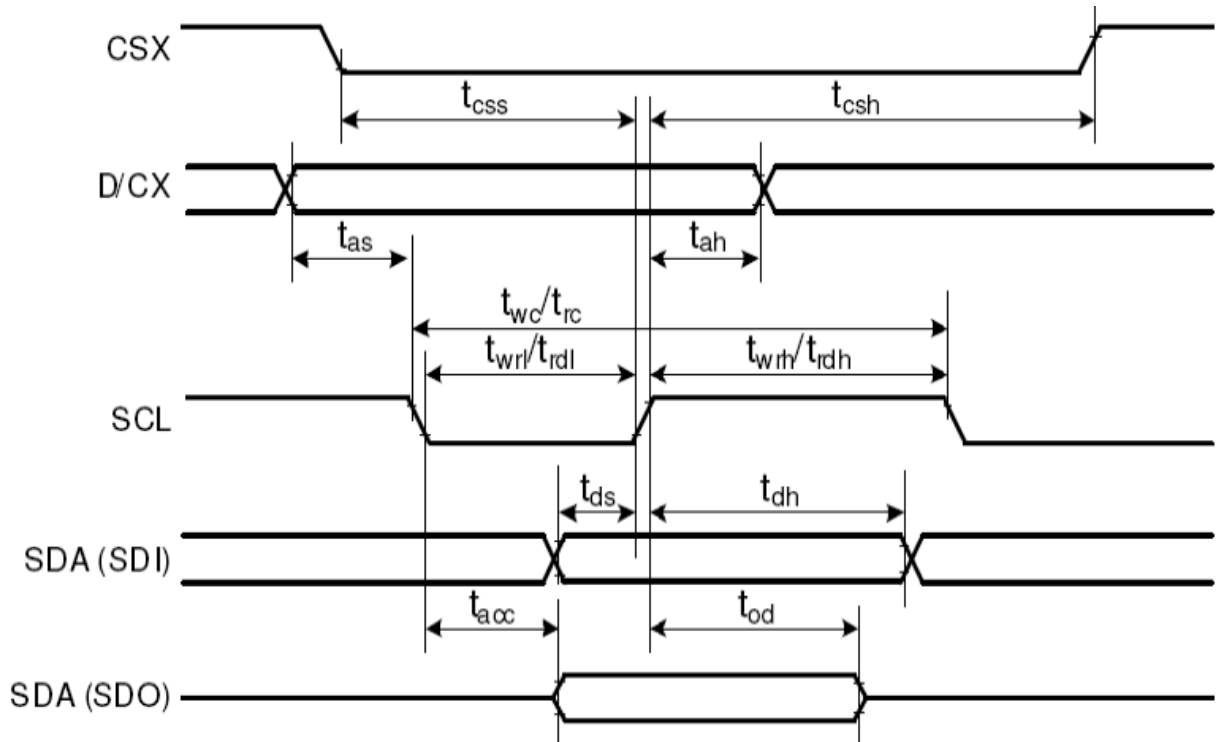

Signal	Symbol	Parameter	min	max	Unit	Description
CSX	$t_{css}$	Chip select time (Write)	15	-	ns	
	$t_{csh}$	Chip select hold time (Read)	60	-	ns	
SCL	$t_{wc}$	Serial clock cycle (Write)	66	-	ns	
	$t_{wrh}$	SCL "H" pulse width (Write)	15	-	ns	
	$t_{wrl}$	SCL "L" pulse width (Write)	15	-	ns	
	$t_{rc}$	Serial clock cycle (Read)	150	-	ns	
	$t_{rdh}$	SCL "H" pulse width (Read)	60	-	ns	
	$t_{rdl}$	SCL "L" pulse width (Read)	60	-	ns	
D/CX	$t_{as}$	D/CX setup time	10	-	ns	
	$t_{ah}$	D/CX hold time (Write / Read)	10	-	ns	
SDA / SDI (Input)	$t_{ds}$	Data setup time (Write)	10	-	ns	
	$t_{dh}$	Data hold time (Write)	10	-	ns	
SDA / SDO (Output)	$t_{acc}$	Access time (Read)	10	50	ns	For maximum CL=30pF
	$t_{od}$	Output disable time (Read)	15	50	ns	For minimum CL=8pF

### 3.4.5 Reset Timing Characteristics

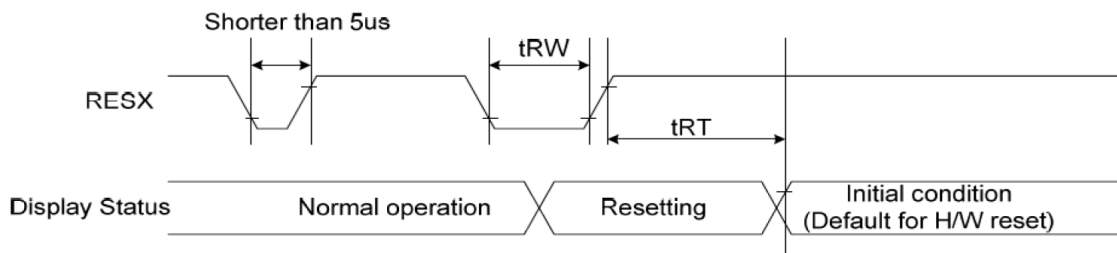

Signal	Symbol	Parameter	Min	Max	Unit
RESX	tRW	Reset pulse duration	10		uS
	tRT	Reset cancel		5 (note 1,5)	mS
				120 (note 1,6,7)	mS

Note 1: The reset cancel includes also required time for loading ID bytes. VCOM setting and other settings from EEPROM to registers. This loading is done every time when there is HW reset cancel time (tRT) within 5 ms after rising edge of RESX.

Note 2: Spike due to an electrostatic discharge on RESX line dose not because irregular system reset according to the table below:

RESX Pulse	Action
Shorter than 5us	Reset Rejected
Longer than 9us	Reset
Between 5us and 9us	Reset starts

Note 3: During the resetting period, the display will be blanked (The display is entering blanking sequence, which maximum time is 120ms, when reset starts in Sleep Out-mode. The display remains the blank state in Sleep In-mode.) and then return to default condition for Hardware Reset.

Note 4: Spike rejection also applies during a valid reset pulse as shown below:

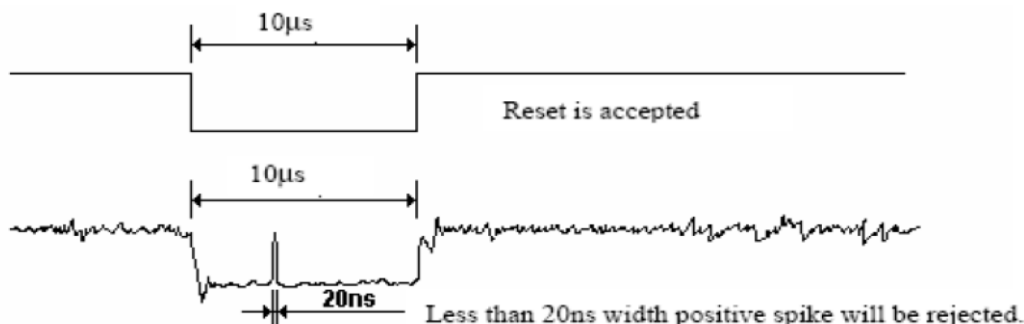

Note 5: When reset applied during Sleep in Mode.

Note 6: When reset applied during Sleep out Mode.

Note 7: It is necessary to wait 5msec after releasing RESX before sending commands. Also Sleep Out command cannot be sent for 120msec.

## 4 OPTICAL SPECIFICATION

### 4.1 OPTICAL CHARACTERISTICS

Measuring instruments: LCD-5100, Eldim, Topcon BM-7  
 Driving condition: VCI = 3.3V, VSS = 0V  
 Backlight: IF=160mA  
 Measured temperature: Ta = 25° C

Item		Symbol	Condition	MIN	TYP	MAX	Unit	Note
Response Time		TR+TF	$\theta=\phi=0^\circ$ Normal Viewing Angle	-	35	50	ms	2
Contrast Ratio		CR		400	500	-		3
Viewing Angle	Left	$\theta_L$	CR $\geq$ 10	-	80	-	deg	4
	Right	$\theta_R$		-	80	-	deg	
	Up	$\phi_U$		-	80	-	deg	
	Down	$\phi_D$		-	80	-	deg	
Colour Chromaticity	Red	Rx	CR $\geq$ 10	0.640	0.660	0.680	-	5
		Ry		0.297	0.317	0.337	-	
	Green	Gx		0.240	0.260	0.280	-	
		Gy		0.555	0.575	0.595	-	
	Blue	Bx		0.121	0.141	0.161	-	
		By		0.055	0.075	0.095	-	
	White	Wx		0.275	0.295	0.315	-	
		Wy		0.297	0.317	0.337	-	
Centre Brightness				-	480	-	cd/m <sup>2</sup>	6
Brightness Distribution				80	-	-	%	7

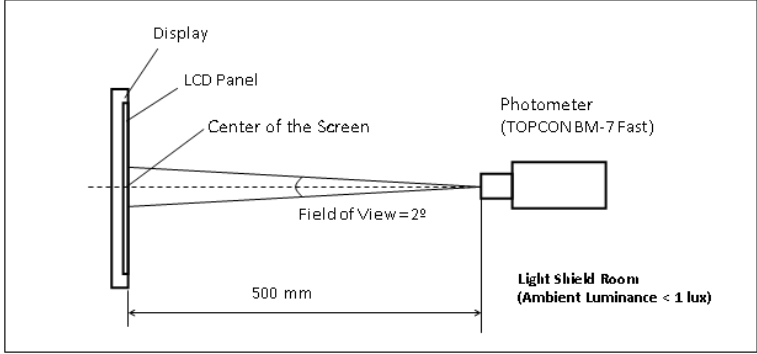
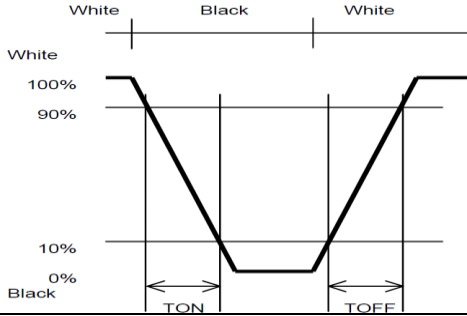
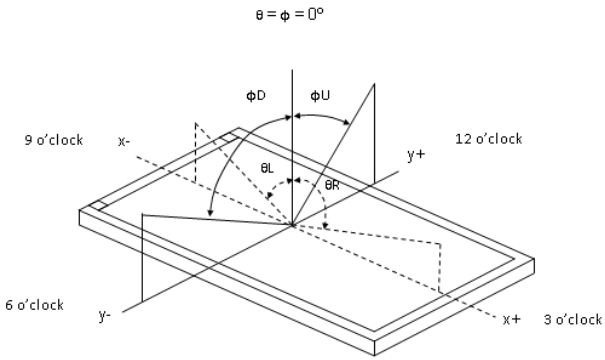

### 4.1.1 Test Method

Note	Item	Test method
1	Setup	<p>The display should be stabilised at a given temperature for 30 minutes to avoid abrupt temperature change during measuring. In order to stabilise the luminance, measurements should be executed after lighting the backlight for 30 minutes in a windless room.</p> 
2	Response time	<p>Measure output signal waveform by the luminance meter when raster of window pattern is changed from white to black and from black to white.</p> 
3	Contrast ratio	<p>Measure maximum brightness and minimum brightness at the centre of the screen by displaying raster or window pattern. Then calculate the ratio between these two values.</p> $\text{Contrast Ratio (CR)} = \frac{\text{Brightness of unselected position (white)}}{\text{Brightness of selected position (black)}}$
4	Viewing angle Horizontal $\theta$ Vertical $\phi$	<p>Move the luminance meter from right to left and up and down and determinate the angles where contrast ratio is 10</p> 
5	Colour chromaticity	Measure chromaticity coordinates x and y of CIE1931 colorimetric system
6	Centre brightness	Measure the brightness at the centre of the screen
7	Brightness distribution	<p>(Brightness distribution) = <math>100 \times B/A \%</math>  A: max. brightness of the 9 points  B: min. brightness of the 9 points</p>

## 5 BACKLIGHT SPECIFICATION

### 5.1 LED DRIVING CONDITIONS

Item	Symbol	Condition	Min	Typ	Max	Unit
Forward Current	IF	Ta=25 °C, VF=3.2V/LED	120	160	-	mA
Forward Voltage	VF	Ta= 25°C, IF= 20mA/LED		3.2		V

**Note:**

- The lifetime of the LED is defined as a period till the brightness of the LED decreases to the half of its initial value.
- This figure is given as a reference purpose only, and not a guarantee.
- This figure is estimated for an LED operating alone.  
The performance of an LED may differ when assembled as a monitor together with a TFT panel due to different environmental temperature.
- Estimated lifetime could vary on a different temperature and usually higher temperature could reduce the life significantly.

### 5.2 LED CIRCUIT

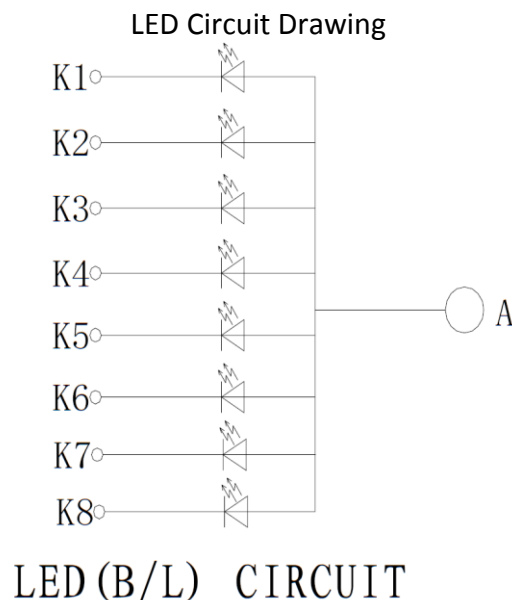

## 6 TOUCH PANEL SPECIFICATION

### 6.1 ELECTRICAL CHARACTERISTICS

Item	Min.	Typ.	Max.	Unit	Note
Linearity	-1.5	-	1.5	%	Analogue X and Y directions
Terminal resistance	100	-	900	Ω	X (Film side)
	100	-	900	Ω	Y (Glass side)
Insulation resistance	20	-	-	MΩ	DC 25V
Voltage	-	5.0	7.0	V	DC
Chattering	-	-	10	ms	100kΩ pull-up

Caution: Operate the touch panel with a polyacetal pen (tip R0.8mm or less) or a finger, avoiding those items with hard or sharp tips such as a ball point pen or a mechanical pencil.

### 6.2 MECHANICAL CHARACTERISTICS

Item	Min.	Typ.	Max.	Unit	Note
Activation force	80	-	-	g	(1)
Durability-surface scratching	Write 100,000	-	-	characters	(2)
Durability-surface pitting	1,000,000	-	-	touches	(3)
Surface hardness	3	-	-	H	JIS K5400

Note (1) Stylus pen Input: R0.8mm polyacetal pen or Finger

Note (2) Measurement for Surface area

- Scratch 100,000 times straight line on the Film with a stylus. Change stylus every 20,000 times
- Force: 250gf
- Speed: 60mm/sec
- Stylus: R0.8 polyacetal tip

Note (3) Hit 1,000,000 times on the Film with a R8.0 silicon rubber.

- Force: 250gf
- Speed: 2 times/sec

## 7 QUALITY ASSURANCE SPECIFICATION

### 7.1 DELIVERY INSPECTION STANDARDS

#### 7.1.1 Inspection Conditions

Inspection distance: 30 cm ± 2 cm  
Viewing angle: ±45°

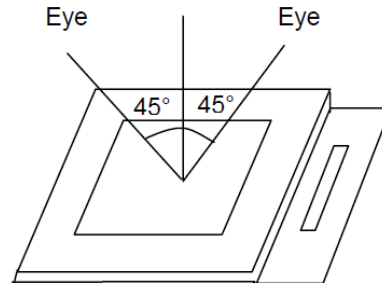

#### 7.1.2 Environmental Conditions

Ambient temperature: 23°C ±5°C  
Ambient humidity: 55±10% RH  
Ambient illumination: 1000~1500 lux

#### 7.1.3 Sampling Conditions

1. Lot size: quantity of shipment lot per model
2. Sampling method:

Sampling Plan		ANSI / ASQC Z1.4-1993
		Normal inspection, Single Sampling
AQL	Major Defect	0.65%
	Minor Defect	1.5%

#### 7.1.4 Definition of Area

A zone: active area  
B zone: viewing area

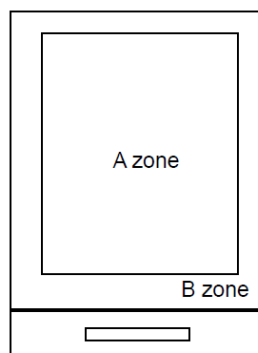

#### 7.1.5 Basic Principle

A set of sample to indicate the limit of acceptable quality level shall be discussed should a dispute occur.

### 7.1.6 Inspection Criteria

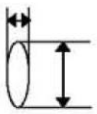
No	Item	Criteria	Rank	Remark																																											
1	Segment Short Segment Missing	Not allowed	MA	X																																											
2	Solder Bridging	Any bridging between components, except common circuit, is not allowed.	MA																																												
3	Outside Dimension	Drawing & specification must be within permissible tolerance. A Area B Area	MA																																												
4	Cold Solder	Cold solder is not allowed.	MA																																												
5	Black(White) Spots, Foreign Substances	<p>1) Round Type</p> <table border="1"> <thead> <tr> <th>Area Dimension**</th> <th colspan="2">Acceptable Q'ty</th> <th>Remark</th> </tr> </thead> <tbody> <tr> <td>≤ 0.1</td> <td colspan="2">Ignore</td> <td rowspan="4"></td> </tr> <tr> <td>≤ 0.2</td> <td>2</td> <td>Ignore</td> </tr> <tr> <td>≤ 0.3</td> <td>1</td> <td>Ignore</td> </tr> <tr> <td>0.3 &lt;</td> <td>0</td> <td>Ignore</td> </tr> </tbody> </table> <p>2) Liner Type</p> <table border="1"> <thead> <tr> <th colspan="2">Dimension</th> <th colspan="2">Acceptable Q'ty</th> <th rowspan="2">Remark</th> </tr> <tr> <th>Length</th> <th>Width</th> <th>A Area</th> <th>B Area</th> </tr> </thead> <tbody> <tr> <td>-</td> <td>≤ 0.025</td> <td colspan="2">Ignore</td> <td rowspan="4"></td> </tr> <tr> <td>≤ 2.5</td> <td>≤ 0.05</td> <td>3</td> <td>Ignore</td> </tr> <tr> <td>≤ 1.5</td> <td>≤ 0.075</td> <td>2</td> <td>Ignore</td> </tr> <tr> <td></td> <td>0.075 &lt;</td> <td colspan="2">Follow round type</td> </tr> </tbody> </table> <p>At (1) &amp; (2) total defect q'ty is must not exceed 5 pieces.</p>	Area Dimension**	Acceptable Q'ty		Remark	≤ 0.1	Ignore			≤ 0.2	2	Ignore	≤ 0.3	1	Ignore	0.3 <	0	Ignore	Dimension		Acceptable Q'ty		Remark	Length	Width	A Area	B Area	-	≤ 0.025	Ignore			≤ 2.5	≤ 0.05	3	Ignore	≤ 1.5	≤ 0.075	2	Ignore		0.075 <	Follow round type		MI	 <p>** : Mean Diameter (X + Y)/2</p>
Area Dimension**	Acceptable Q'ty		Remark																																												
≤ 0.1	Ignore																																														
≤ 0.2	2	Ignore																																													
≤ 0.3	1	Ignore																																													
0.3 <	0	Ignore																																													
Dimension		Acceptable Q'ty		Remark																																											
Length	Width	A Area	B Area																																												
-	≤ 0.025	Ignore																																													
≤ 2.5	≤ 0.05	3	Ignore																																												
≤ 1.5	≤ 0.075	2	Ignore																																												
	0.075 <	Follow round type																																													
6	OC Spot	<table border="1"> <thead> <tr> <th>Area Dimension**</th> <th colspan="2">Acceptable Q'ty</th> <th>Remark</th> </tr> </thead> <tbody> <tr> <td>≤ 0.2</td> <td colspan="2">Ignore</td> <td rowspan="3"></td> </tr> <tr> <td>≤ 0.8</td> <td>A Area</td> <td>Ignore</td> </tr> <tr> <td>≤ 1.0</td> <td>1</td> <td>Ignore</td> </tr> </tbody> </table>	Area Dimension**	Acceptable Q'ty		Remark	≤ 0.2	Ignore			≤ 0.8	A Area	Ignore	≤ 1.0	1	Ignore	MI																														
Area Dimension**	Acceptable Q'ty		Remark																																												
≤ 0.2	Ignore																																														
≤ 0.8	A Area	Ignore																																													
≤ 1.0	1	Ignore																																													
7	Air Bubbles Between Glass & Polarizer (Polarizer Defects)	<table border="1"> <thead> <tr> <th>Area Dimension**</th> <th colspan="2">Acceptable Q'ty</th> <th>Remark</th> </tr> </thead> <tbody> <tr> <td>≤ 0.15</td> <td colspan="2">Ignore</td> <td rowspan="5"></td> </tr> <tr> <td>≤ 0.3</td> <td>3</td> <td>Ignore</td> </tr> <tr> <td>≤ 0.5</td> <td>2</td> <td>Ignore</td> </tr> <tr> <td>≤ 0.7</td> <td>1</td> <td>Ignore</td> </tr> <tr> <td>Total</td> <td>5</td> <td>Ignore</td> </tr> </tbody> </table>	Area Dimension**	Acceptable Q'ty		Remark	≤ 0.15	Ignore			≤ 0.3	3	Ignore	≤ 0.5	2	Ignore	≤ 0.7	1	Ignore	Total	5	Ignore	MI																								
Area Dimension**	Acceptable Q'ty		Remark																																												
≤ 0.15	Ignore																																														
≤ 0.3	3	Ignore																																													
≤ 0.5	2	Ignore																																													
≤ 0.7	1	Ignore																																													
Total	5	Ignore																																													

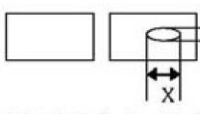
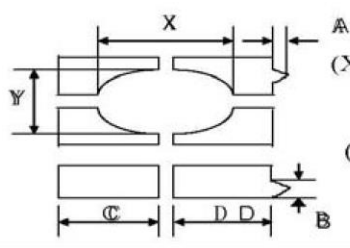
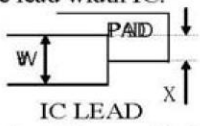
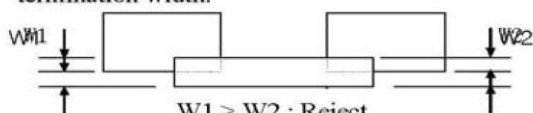
No	Item	Criteria	Rank	Remark								
8	Pin hole (On Segment)	 <p><math>(X+Y)/2 \leq 0.2\text{mm}</math> Within 1 per one segment (Less than 0.1mm is not counted) Total defects q'ty is must not exceed 5 pieces.</p>	MI									
9	Segment Deformation	 <p><math>(X+Y)/2 \leq 0.2\text{mm}</math> <math>A \leq 0.2\text{mm}</math> <math>B \leq 0.2\text{mm}</math> <math>(C-D) \leq 0.2\text{mm}</math></p> <table border="1" data-bbox="558 705 1165 817"> <thead> <tr> <th></th> <th>Acceptable Q'ty</th> </tr> </thead> <tbody> <tr> <td>Dot, Segment</td> <td>1</td> </tr> <tr> <td>LCD</td> <td>5</td> </tr> <tr> <td><math>\leq 0.1</math></td> <td>Ignore all defect</td> </tr> </tbody> </table> <p>Each visible dot must be more than half effective dot area</p>		Acceptable Q'ty	Dot, Segment	1	LCD	5	$\leq 0.1$	Ignore all defect	MI	$(X + Y)/2 \leq 0.2\text{mm}$
	Acceptable Q'ty											
Dot, Segment	1											
LCD	5											
$\leq 0.1$	Ignore all defect											
10	Color Variation	Within the three colors, except LCD Standard color is acceptable.	MI									
11	Glass & Polarizer Scratch	Follow NO.5(2) condition	MI									
12	Solder Ball	<p>1)Acceptable if the size of void is less than 0.18mm</p> <p>2)Acceptable if a solder ball is not movable</p> <p>3)Rejectable if the solder ball exceed 5EA in <math>2.54 \times 2.54\text{mm}</math> area.</p>	MI									
13	Miss Alignment	<p>1)Acceptable if it dose not exceed 50% of the lead width IC.</p>  <p><math>X \leq W/2</math> : Accept <math>X &gt; W/2</math> : Reject</p> <p>2)Rejectable, provided that it does exceed 50% of the component termination width.</p>  <p><math>W1 &gt; W2</math> : Reject</p>										

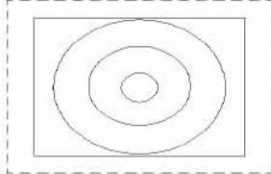
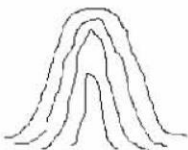
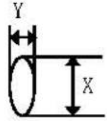
No	Item	Criteria	Rank	Remark																																																
14	Touch Panel	<p>1) Round Type、 Foreign Substances</p> <table border="1"> <thead> <tr> <th rowspan="2">Area Dimension**</th> <th colspan="2">Acceptable Qty</th> <th rowspan="2">Remark</th> </tr> <tr> <th>A Area</th> <th>B Area</th> </tr> </thead> <tbody> <tr> <td>≤ 0.1</td> <td colspan="2">Ignore</td> <td rowspan="4"></td> </tr> <tr> <td>≤ 0.2</td> <td>2</td> <td>Ignore</td> </tr> <tr> <td>≤ 0.3</td> <td>1</td> <td>Ignore</td> </tr> <tr> <td>0.3 &lt;</td> <td>0</td> <td>Ignore</td> </tr> </tbody> </table> <p>2) Liner Type &amp; Scratch</p> <table border="1"> <thead> <tr> <th colspan="2">Dimension</th> <th colspan="2">Acceptable Qty</th> <th rowspan="2">Remark</th> </tr> <tr> <th>Length</th> <th>Width</th> <th>A Area</th> <th>B Area</th> </tr> </thead> <tbody> <tr> <td>-</td> <td>W ≤ 0.025</td> <td colspan="2">Ignore</td> <td rowspan="5">Ignore</td> </tr> <tr> <td>L ≤ 3.0</td> <td rowspan="2">W ≤ 0.05</td> <td colspan="2">Ignore</td> </tr> <tr> <td>3.0 &lt; L ≤ 5.0</td> <td colspan="2">2</td> </tr> <tr> <td>≤ 7</td> <td>W ≤ 0.1</td> <td colspan="2">1</td> </tr> <tr> <td>-</td> <td>W &gt; 0.1</td> <td colspan="2">Follow round type</td> </tr> </tbody> </table> <p>4) Newton Ring</p> <p>a) Regular</p>  <p>The area of the Newton ring is more than 1/3 area of the touch panel It's NG. The area of the Newton ring is less than 1/3 area of the touch panel It's OK.</p> <p>b) None-regularity</p>  <p>The area of the Newton ring is more than 1/2 area of the touch panel It's NG. The area of the Newton ring is less than 1/2 area of the touch panel It's OK.</p>	Area Dimension**	Acceptable Qty		Remark	A Area	B Area	≤ 0.1	Ignore			≤ 0.2	2	Ignore	≤ 0.3	1	Ignore	0.3 <	0	Ignore	Dimension		Acceptable Qty		Remark	Length	Width	A Area	B Area	-	W ≤ 0.025	Ignore		Ignore	L ≤ 3.0	W ≤ 0.05	Ignore		3.0 < L ≤ 5.0	2		≤ 7	W ≤ 0.1	1		-	W > 0.1	Follow round type		MI	 <p>** : Mean Diameter (X + Y)/2</p>
Area Dimension**	Acceptable Qty			Remark																																																
	A Area	B Area																																																		
≤ 0.1	Ignore																																																			
≤ 0.2	2	Ignore																																																		
≤ 0.3	1	Ignore																																																		
0.3 <	0	Ignore																																																		
Dimension		Acceptable Qty		Remark																																																
Length	Width	A Area	B Area																																																	
-	W ≤ 0.025	Ignore		Ignore																																																
L ≤ 3.0	W ≤ 0.05	Ignore																																																		
3.0 < L ≤ 5.0		2																																																		
≤ 7	W ≤ 0.1	1																																																		
-	W > 0.1	Follow round type																																																		

### 7.1.7 Classification of Defects

Visual defects (except no or wrong label) are treated as minor defects, while electrical defects are treated as major defects.

Two minor defects are equal to one major defect in lot sampling inspection.

### 7.1.8 Identification / marking criteria

Any unit with illegible / wrong / double or no marking / label shall be rejected.

## **7.2 DEALING WITH CUSTOMER COMPLAINTS**

---

### **7.2.1 Non-conforming analysis**

Purchaser should supply Densitron with detailed data of non-conforming sample. After accepting it, Densitron should complete the analysis in two weeks from receiving the sample.

If the analysis cannot be completed on time, Densitron must inform the purchaser.

### **7.2.2 Handling of non-conforming displays**

If any non-conforming displays are found during customer acceptance inspection which Densitron is clearly responsible for, return them to Densitron.

Both Densitron and customer should analyse the reason and discuss the handling of non-conforming displays when the reason is not clear.

Equally, both sides should discuss and come to agreement for issues pertaining to modification of Densitron quality assurance standard.



## 8 RELIABILITY SPECIFICATION

### 8.1 RELIABILITY TESTS

Test Item		Test Condition	
Durability Test	High Temperature Storage	Ta= 80°C	96h
	Low Temperature Storage	Ta=-30°C	96h
	Temperature Cycle Storage	-20°C for 30 min, then 70°C for 30 min, 20 cycles	
	High Temperature Operation	Tp= 70°C	96h
	Low Temperature Operation	Tp= -20°C	96h
	High Temperature & Humidity Operation	Tp= 40°C RH= 90% 96h Non condensing	
	Thermal Shock Resistance	The sample should be allowed to stand the following 5 cycles of operation: TSTL for 30 minutes -> normal temperature for 5 minutes -> TSTH for 30 minutes -> normal temperature for 5 minutes, as one cycle, then taking it out and drying it at normal temperature, and allowing it stand for 24 hours	
	Box Drop Test	1 Corner 3 Edge 6 faces, 66 cm (Medium Box)	

Note: Ta=ambient temperature Tp= Panel temperature

Notes:

1. No dew condensation to be observed.
2. The function test shall be conducted after 4 hours storage at the normal temperature and humidity after removed from the test chamber.
3. No cosmetic or functional defects should be allowed.
4. Total current consumption should be less than twice the initial value.

## 9 HANDLING PRECAUTIONS

### **Safety**

If the LCD panel breaks, be careful not to get the liquid crystal fluid in your mouth or in your eyes. If the liquid crystal touches your skin or clothes, wash it off immediately using soap and plenty of water.

### **Mounting and Design**

Place a transparent plate (e.g. acrylic, polycarbonate or glass) on the display surface to protect the display from external pressure. Leave a small gap between the transparent plate and the display surface.

When assembling with a zebra connector, clean the surface of the pads with alcohol and keep the surrounding air very clean.

Design the system so that no input signal is given unless the power supply voltage is applied.

### **Caution during LCD cleaning**

Lightly wipe the display surface with a soft cloth soaked with Isopropyl alcohol, Ethyl alcohol or Trichlorotrifluoroethane.

Do not wipe the display surface with dry or hard materials that will damage the polariser surface.

Do not use aromatic solvents (toluene and xylene), or ketonic solvents (ketone and acetone).

### **Caution against static charge**

As the display uses C-MOS LSI drivers, connect any unused input terminal to VDD or VSS. Do not input any signals before power is turned on. Also, ground your body, work/assembly table and assembly equipment to protect against static electricity.

### **Packaging**

Displays use LCD elements, and must be treated as such. Avoid strong shock and drop from a height. To prevent displays from degradation, do not operate or store them exposed directly to sunshine or high temperature/humidity.

### **Caution during operation**

It is indispensable to drive the display within the specified voltage limit since excessive voltage shortens its life. Direct current causes an electrochemical reaction with remarkable deterioration of the display quality. Give careful consideration to prevent direct current during ON/OFF timing and during operation. Response time is extremely delayed at temperatures lower than the operating temperature range while, at high temperatures, displays become dark. However, this phenomenon is reversible and does not mean a malfunction or a display that has been permanently damaged. If the display area is pushed on hard during operation, some graphics will be abnormally displayed but returns to a normal condition after turning off the display once. Even a small amount of condensation on the contact pads (terminals) can cause an electro-chemical reaction which causes missing rows and columns. Give careful attention to avoid condensation.

### **Storage**

Store the display in a dark place where the temperature is 25°C ± 10°C and the humidity below 50%RH. Store the display in a clean environment, free from dust, organic solvents and corrosive gases.

Do not crash, shake or jolt the display (including accessories).

Product No.	DET035HVNMRSSS-1A	REV. 1.0
-------------	-------------------	----------

Page	26 / 26
------	---------