

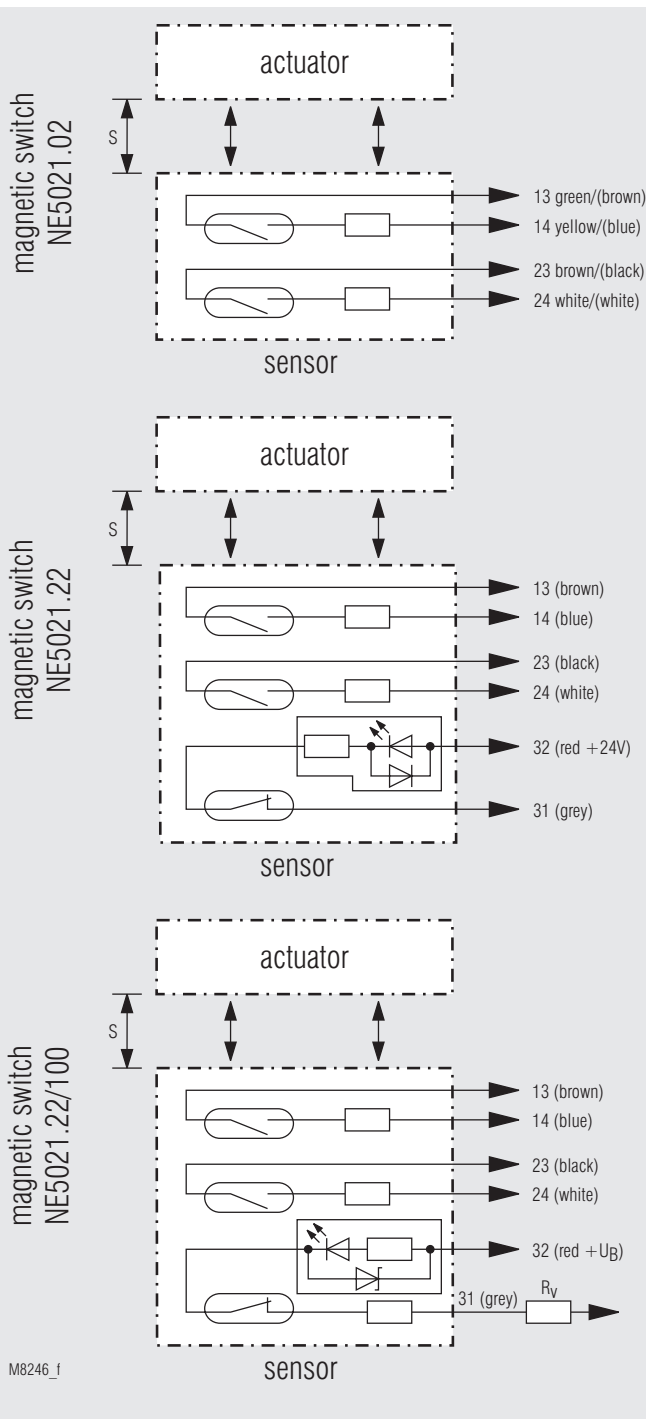

0239133

- Usable for safety application by using a correctly installed and connected, security module (e. g. BG 5925/920 or LG 5925/920)
- According to IEC/EN 60 204-1
- Standard switching distance: $S_{an} \leq 7 \text{ mm}$
 $S_{ab} \geq 18 \text{ mm}$
- Max. number of switches in series:
 - 6 NE 5021 on control unit BG 5925/920 or LG 5925/920
 - 10 NE 5021 on multifunctional safety timer UG 6960 and UG 6961
 - 10 NE 5021 on multifunctional safety module UG 6980
 - 20 NE 5021 on multifunctional safety module UG 6970
 - 20 NE 5021 on multifunction module BH 5910
- 2 NO contacts or 2 NO contacts / 1 NC contact
- Contacts protected against welding
- Very long service life
- Easy to mount and service
- Manipulation is difficult due to coded sensor
- Protection class IP 67

Block Diagram



M8246_f

Function Diagram

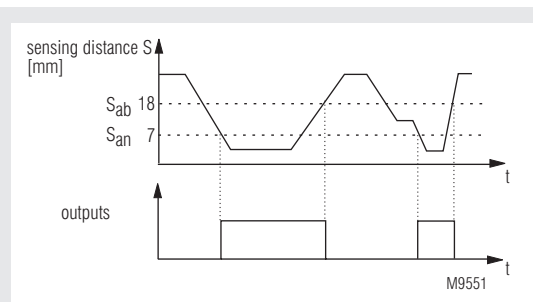

Additional information to this subject

- Data sheet control unit BG 5925/920 or LG 5925/920 for safety switch

Approvals and Marking



Application

The magnetic switch NE 5021 is suitable to detect the closed state of safety gates, sliding gates and removable covers also under rough ambient conditions or for special hygienic requirements. The magnetic switch can also be used at sluggish or inaccurate positioned doors.

- To be used with:
- BG 5925/920 or LG 5925/920 control unit.
Max. 6 NE 5021 and 1 E-stop button in series can be connected
 - UG 6960 and UG 6961 multifunctional safety timer.
Max. 10 NE 5021 and 1 E-stop button in series can be connected
 - UG 6980 multifunctional safety module.
Max. 10 NE 5021 and 1 E-stop button in series can be connected
 - UG 6970 multifunctional safety module.
Max. 10 NE 5021 for each safety function and 1 E-stop button can be connected
 - BH 5910 multifunction safety relay.
Max. 2 x 10 NE 5021 and 1 E-stop button can be connected

Function

The magnetic switch consists of an transmitter and a receiver. The transmitter is magnetic coded. The contacts of the receiver switch when it detects the coding of the transmitter. Manipulation with a standard magnet will not make the contact switching. The contacts are protected against short circuit currents by series resistors, so they cannot weld.

The sensor with 2 NO / 1 NC contacts is available in 2 variants:
 NE 5021.22 The connector 32 (red) is designed for 24 V DC.
 NE 5021.22/100 The connector 31 (grey) has to be connected via a series resistor R_v . R_v is depending on the connected voltage. R_v is calculated as follows:

$$R_v = \frac{(U_B - 3,3) V}{I_n}$$

$U_B \text{ max.} = \text{DC } 30 \text{ V}$
 $I_n \text{ typ.} = 6 \text{ mA}$
 $I_n \text{ max.} = 10 \text{ mA}$

Indication

red LED: on, when NC contact not activated at NE 5021.22 and NE 5021.22/100.

Connections

The NE 5021 magnetic switch has to be connected according to the application examples below.

Technical Data

Switching distances

Safe switching distances without mounting difference

S_{an} : $\leq 7 \text{ mm}$
 S_{ab} : $\geq 18 \text{ mm}$
 undefined situation: 7.1 ... 17.9 mm

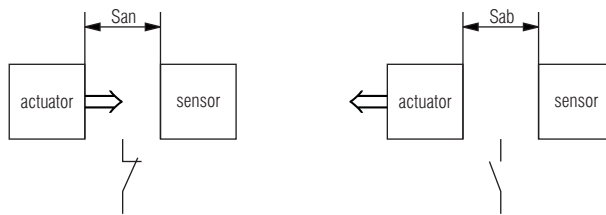

M8351_a

Safe switching distances with mounting difference

The switching distance S_{an} is valid for mounting method A and B when the switch is mounted on non ferromagnetic material. The min. distance between transmitter and receiver should be 3 mm. The receiver must not be used as mechanical stop for the transmitter.

Mounting Difference / Switching Distance S_{an} Mounting Method A

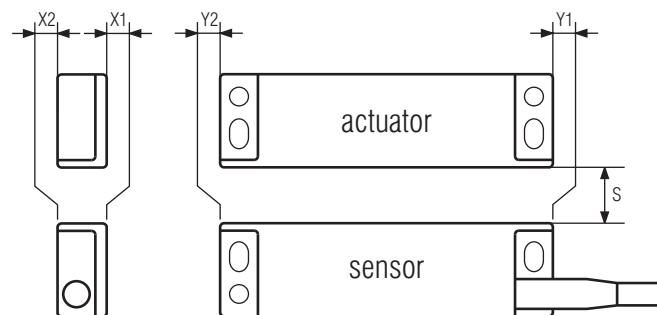

M8250_a

NE 5021.22 and /100	
Mounting diff.	S_{an}
$Y_1 = \text{max. } 7 \text{ mm}$	$\leq 9 \text{ mm}$
$Y_2 = \text{max. } 5 \text{ mm}$	$\leq 6 \text{ mm}$
$X_1 = \text{max. } 7 \text{ mm}$	$\leq 6 \text{ mm}$
$X_2 = \text{max. } 7 \text{ mm}$	$\leq 6 \text{ mm}$

NE 5021.02	
Mounting diff.	S_{an}
$Y_1 = \text{max. } 2 \text{ mm}$	$\leq 9 \text{ mm}$
$Y_2 = \text{max. } 2 \text{ mm}$	$\leq 6 \text{ mm}$
$X_1 = \text{max. } 3 \text{ mm}$	$\leq 6 \text{ mm}$
$X_2 = \text{max. } 3 \text{ mm}$	$\leq 6 \text{ mm}$

Mounting Difference / Switching Distance S_{an} Mounting Method B

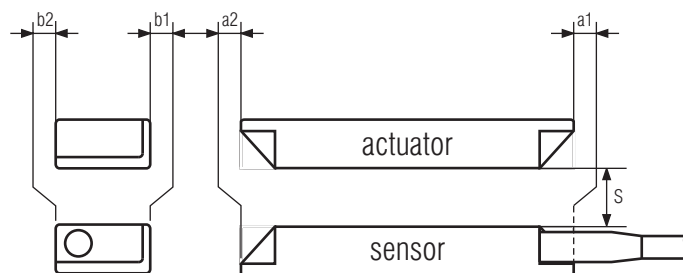

M8249_a

NE 5021.22 and /100	
Mounting diff.	S_{an}
$a_1 = \text{max. } 5 \text{ mm}$	$\leq 11 \text{ mm}$
$a_2 = \text{max. } 5 \text{ mm}$	$\leq 9 \text{ mm}$
$b_1 = \text{max. } 5 \text{ mm}$	$\leq 8 \text{ mm}$
$b_2 = \text{max. } 5 \text{ mm}$	$\leq 8 \text{ mm}$

NE 5021.02	
Mounting diff.	S_{an}
$a_1 = \text{max. } 2 \text{ mm}$	$\leq 11 \text{ mm}$
$a_2 = \text{max. } 2 \text{ mm}$	$\leq 9 \text{ mm}$
$b_1 = \text{max. } 3 \text{ mm}$	$\leq 8 \text{ mm}$
$b_2 = \text{max. } 3 \text{ mm}$	$\leq 8 \text{ mm}$

Technical Data**Output****Contacts**

NE 5021.02: 2 NO contacts
 NE 5021.22, NE 5021.22/100: 2 NO / 1 NC contacts
Contact type: Reed contacts

NO contact

Switching voltage: typ. DC 24 V
 max. DC 30 V
 Switching current: max. 100 mA
 Series resistor for contacts: 10 Ω
 Electrical life: > 2 x 10⁶ switching cycles at
 DC 24 V / 100 mA

NC contact

Switching voltage U_B
 adjusted by R_V and I_n : $R_V = \frac{(U_B - 3.3) V}{I_n}$

U_B max.: DC 30 V
 I_n typ.: 6 mA
 I_n max.: 10 mA

General Data

Temperature range: - 25 ... + 75 °C
Shock resistance: 30 g / 11 ms
Vibration resistance: 10 g, 10 ... 150 Hz
Protection class: IP 67 IEC/EN 60 529
Housing: Polyamid, glas-fibre reinforced with
 V0 behaviour according to UL subj. 94
Connection of cable: 0.25 mm² with tinned wire ends
Length of cable: 5 m
Mounting: Screw M4
 with plain washer EN ISO 7092
Weight:
 Transmitter: 45 g
 Receiver: 120 g

Dimensions

Width x height x depth:
 Transmitter: 88 x 14 x 25 mm
 Receiver: 88 x 14 x 25 mm

Statistic related data

λ_{total} :	500	FIT
MTTF:	228,3	a
d_{op} :	365	days/a
h_{op} :	24	h/day
t_{cycle} :	3600	s/cycle
n_{op} :	8760	cycles/a
B_{10} :	200000	cycles

Standard Type

NE 5021.02
 Article number: 0054695 (for Transmitter and Receiver)
 • Output: 2 NO contacts
 • Connection cable: 5 m

Variants

NE 5021.22/100: External series resistor R_V is necessary
 in series to NC contact

Ordering example for variants:

NE 5021 . . . / . . .
 Variant, if required
 Contact
 Type

Connection Examples

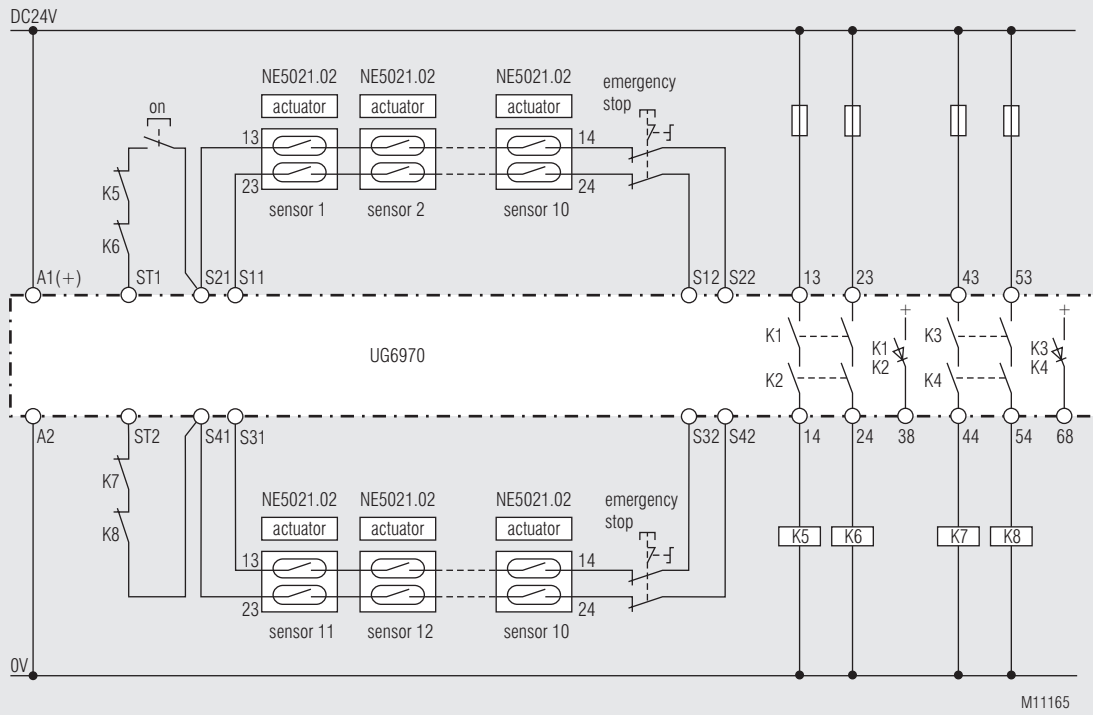

Safety function each 10 magnetic switches NE 5021 +1 E-stop button in series on multifunction safety relay UG6970
 Operation mode: 2 (Fkt1 = MANUAL ; Fkt2 = AUTO)
 Safety function 1: E-stop with cross fault detection (1) , Manual-Start
 Safety function 2: E-stop with cross fault detection (1) , Auto-Start

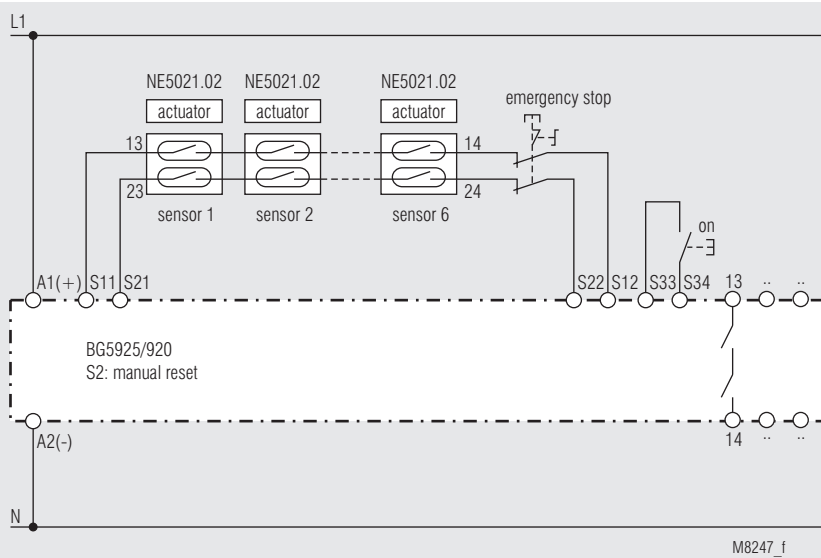

6 magnetic switches NE 5021 + 1 E-stop button in series on 1 control unit BG 5925/920, with manual reset

Connection Examples

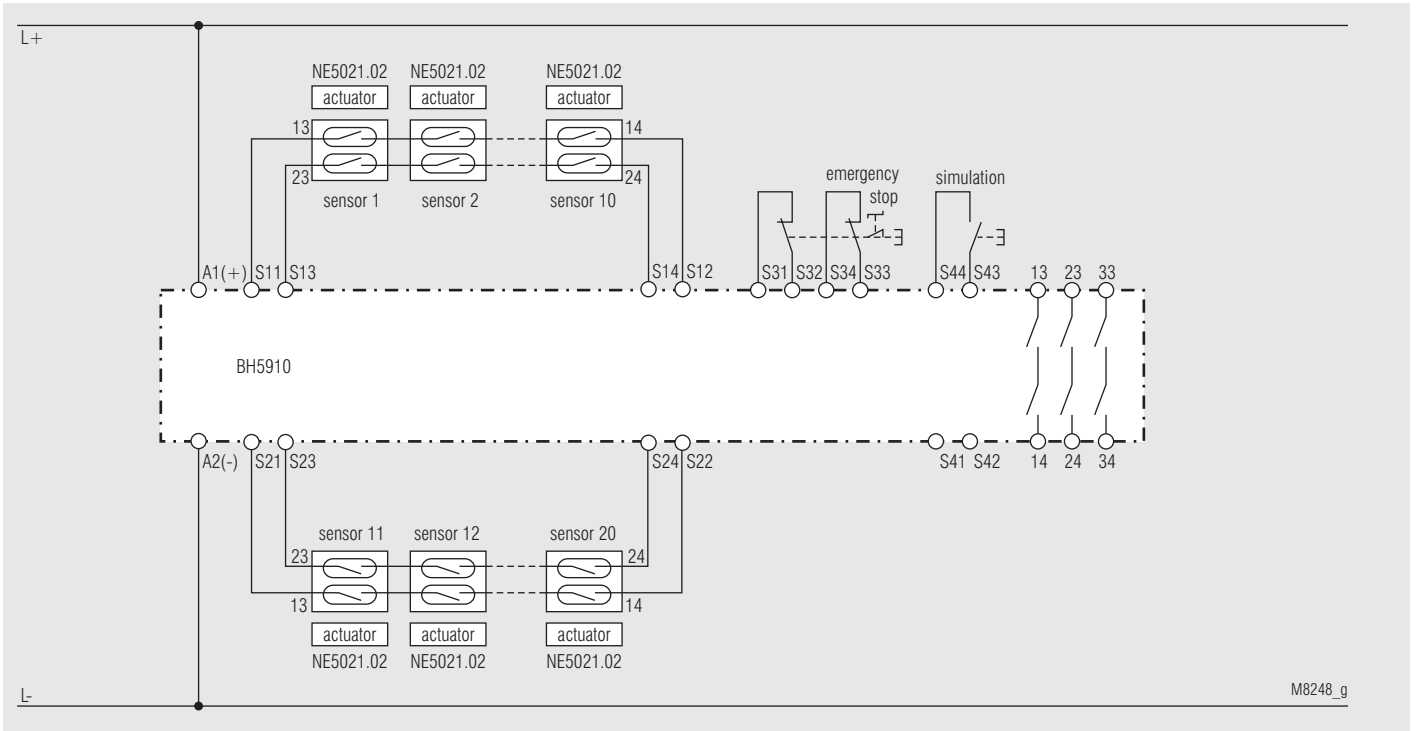

20 magnetic switches NE 5021 + 1 E-stop button, 1 simulation button on multifunction safety module BH 5910

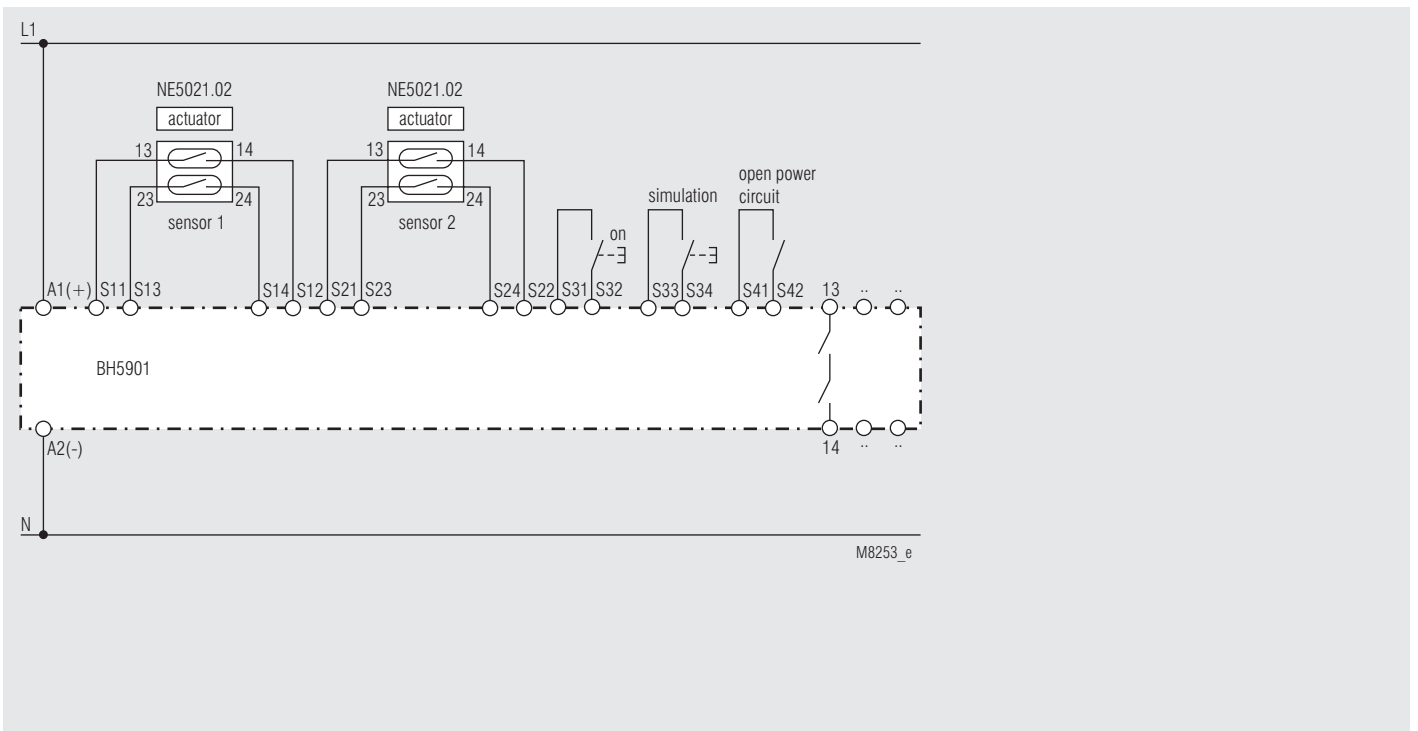

2 magnetic switches NE 5021 on Gate monitor BH 5901 with manual restart and simulation button according to EN 201. The sensors are shown in non active state.

Dimensions

