

MINISTOP
Motor Brake Relay
BI 9023



- DC brake with one way rectified brake voltage
- Suitable for all squirrel cage motors
- Easy to fit also in existing circuits
- Wear- and maintenance free
- To mount on 35 mm DIN rail
- Adjustable brake current to 80 A
- Adjustable braking time 1 ... 20 s (others on request)
- 90 mm width

Approvals and Marking



Function Diagram

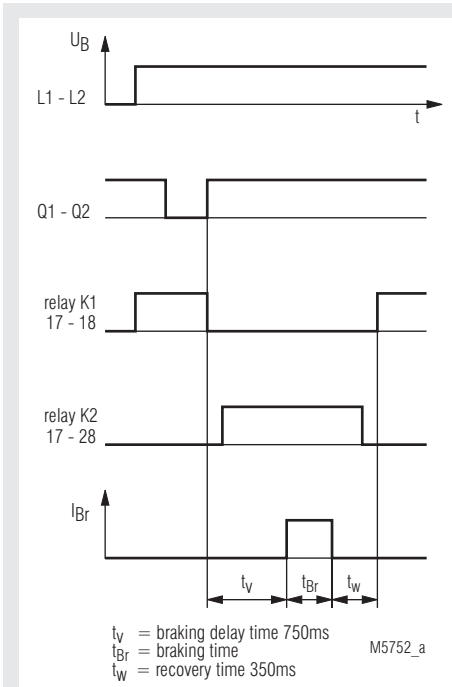

Application

- Saws
- Centrifuges
- Woodworking machines
- Textile machines
- Conveyor systems

Function

The auxiliary supply is connected to terminals A1 - A2. The braking voltage is connected to terminals L1 - L2. A green LED indicates that supply voltage is connected. The interlocking contact of the motor contactor is connected to Q1 - Q2. The motor can be started. If the braking voltage is missing the unit goes into failure state and the motor cannot be started.

The DC braking voltage is supplied from the terminals T1 - T2 to the motor.

When the contact on terminals Q1 - Q2 is opened the brake unit goes into braking mode. When closing the contact again the output 17 - 18 opens and 17 - 28 closes. The motor contactor K1 is disabled. By a special time control it is guaranteed, that the motor contactor K1 is open before the braking contactor K2 comes and the braking current is switched on. As a result the back EMF voltage is already low so the power semiconductor cannot be destroyed by induce high voltage.

A braking cycles has the following sequence. The motor contactor is switched off. After a fixed safety time the contact 17 - 28 closes and switches the braking current flows through the motor windings. After the time is elapsed, the braking current is switched off, K2 is de-energized and contact 17 - 18 closes to enable a new start with K1.

Block Diagram

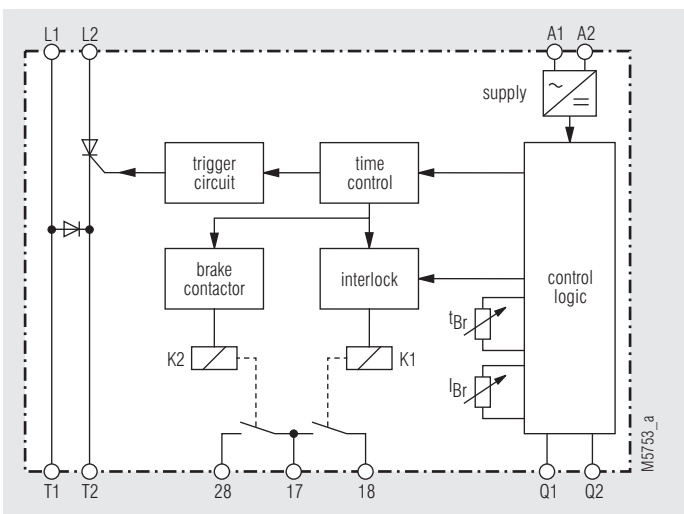

Circuit Diagram

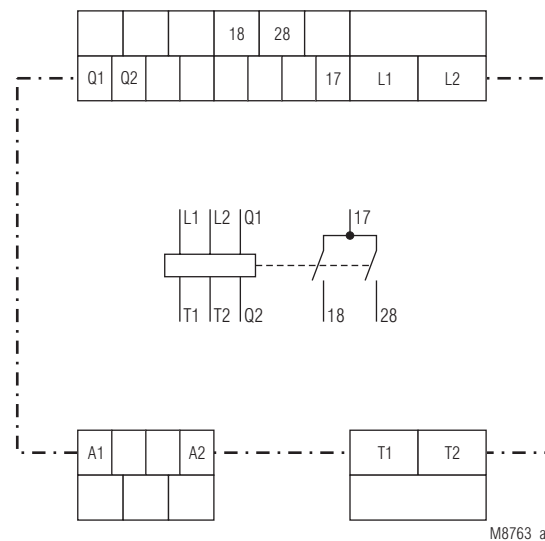

BI 9023 Device with $U_H = AC 400 V$

Circuit Diagram

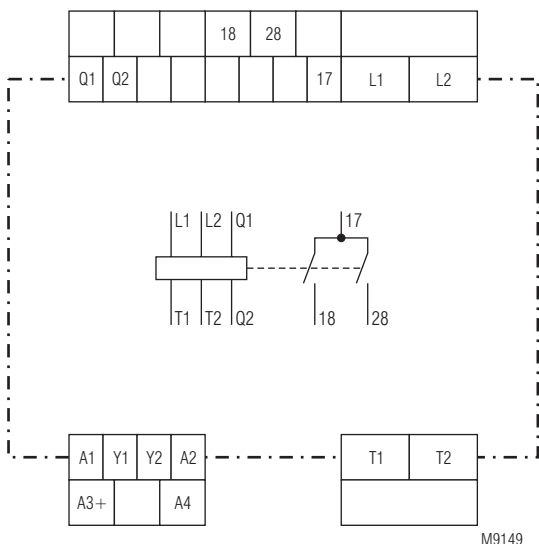

BI 9023 Device with $U_H = AC 230 V, 115 V, DC 24 V$

Indicators

Green LED: ON, when auxiliary supply connected
 „ON“: Flashing, when braking

Relais K1

Yellow LED: ON, when contact 17 - 18 closed

Relais K2

Yellow LED: ON, when contact 17 - 28 closed
 „ERROR“: Flashing, when contact 17-28 open
 1*): Overtemperature on thyristor (internal)
 6*): Wrong frequency
 4*): Voltage L1 - L2 missing

1 - 6*) = Number of pulses in flashing sequence

Notes

The braking current is generated by phase control. The value is depending on the voltage connected to L1 - L2, the current setting and resistance of the motor windings. It is therefore possible, that the current with full scale setting is much higher than the permitted max current.

To achieve the optimum braking effect, the braking current I_B should be max 1.8 to 2 times the motor nominal current. This is the saturation current of the magnetic field necessary to brake. A higher current leads only to overheating of the motor. A better braking effect is achieved, when using 2 or more motor windings to brake. The permitted duty cycle is depending on braking current and ambient temperature.

Technical Data

Nominal voltage U_N:	3 AC 200 V -10 % ... 480 V +10 %
Auxiliary voltage U_H:	Device with AC 400 V
(Standardtype):	A1/A2, AC 400 V, +10 %, -15 %,
Device with AC 115/230 V	A1/A2, AC 115 V, +10 %, -15 %,
DC 24 V:	bridge A1-Y1, bridge A1-Y2 A1/A2, AC 230 V, +10 %, -15 %, bridge Y1-Y2 A3/A4, DC 24 V, +10 %, -15 %, no bridge
Nominal frequency:	50/60 Hz
Motor power	
at 400 V:	15 kW
max adjustable braking current:	60 A at 60 cycles / h and 20 s braking time, 80 A at 20 cycles / h and 20 s braking time
Fuse, superfast:	$\leq 6600 A^2s$
Braking voltage:	DC 0 ... 90 V
Braking time:	adjustable 1 ... 20 s
Back-EMF braking time delay:	750 ms
Wire connection	
Load terminals:	1 x 10 mm ² solid 1 x 6 mm ² stranded ferruled A current of 60 A or 80 A is permitted at a.m. duty cycles for 6 mm ² wiring
Control terminals:	1 x 4 mm ² solid or 1 x 2.5 stranded ferruled (isolated) or 2 x 1.5 mm ² stranded ferruled (isolated) DIN 46 228-1/-2/-3/-4 or 2 x 2.5 mm ² stranded ferruled DIN 46 228-1/-2/-3
Wire fixing	
Load terminals:	Plus-minus terminal screws M 4 box terminals with self-lifting clamping piece
Control terminals:	Plus-minus terminal screws M 3.5 box terminals with self-lifting clamping piece
Mounting:	To mount on 35 mm DIN rail EN 50 022
General Data	
Temperature range:	0 ... + 45 °C
Storage temperature:	- 25 ... + 75 °C
Clearance and creepage distances	
rated impuls voltage / pollution degree	
Controlvoltage to auxiliary-voltage, motor voltage:	4 kV / 2 IEC 60 664-1
EMC	
Electrostatic discharge:	8 kV (air) IEC/EN 61 000-4-2
HF-irradiation:	10 V/m IEC/EN 61 000-4-3
Fast transients:	2 kV IEC/EN 61 000-4-4
Surge voltages between	
wires for power supply:	1 kV IEC/EN 61 000-4-5
between wire and ground:	2 kV IEC/EN 61 000-4-5
Degree of protection	
Housing:	IP 40 IEC/EN 60 529
Terminals:	IP 20 IEC/EN 60 529
Vibration resistance:	Amplitude 0.35 mm Frequency 10 ... 55 Hz, IEC/EN 60 068-2-6
Climate resistance:	0 / 055 / 04 IEC/EN 60 068-1
Power consumption for control:	2 VA
Contacts:	2 NO 5 A / AC 400 V
Degree of protection:	IP 20 IEC/EN 60 529
Weight:	780 g
Dimensions	
Width x height x depth:	90 x 85 x 120 mm

Standard Type

BI 9023 60 A AC 400 V 50/60 Hz 1 ... 20 s
 Article number: 0057302
 Width: 90 mm

Ordering Example

BI 9023 60 A AC 400 V 50 / 60 Hz 1 ... 20 s

Type
 max braking current
 Nominal voltage
 Nominal frequency
 Braking time

Control Input

Opening the contact on terminals Q1 - Q2 enables the braking cycle, closing the contact will start the braking

Relay Outputs

17, 18: Control of motor contactor
 17, 28: Control of braking contactor

Adjustment Facilities

Potentiometer	Description	Initial setting
I_{Br}	braking current	left end of scale
t_{Br}	braking time	middle of scale

Set-up Procedure

The braking time t_{Br} is adjusted on the unit together with the braking current I_{Br} (max 1.8 ... 2 I_N). If the motor has stopped and is still humming, the braking current is too high or the braking time too long. Current and time has then to be adjusted accordingly.

To avoid damage of the unit the braking current should be verified with a moving coil or true RMS current meter.

Connection Diagram

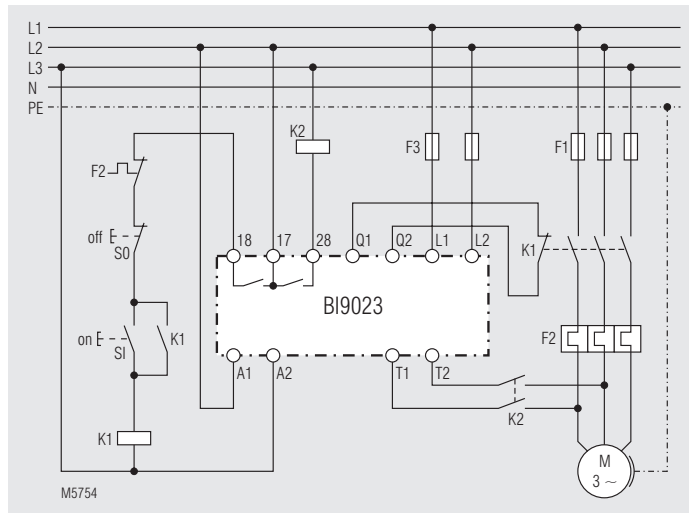

Basic circuit for standardtype
 BI 9023 with $U_H = AC 400 V$

