

LIQUID CRYSTAL DISPLAY MODULE

Product Specification

CUSTOMER	Standard
CUSTOMER PART NUMBER	
PRODUCT NUMBER	DET070WSNLNT0M-2A

Product Mgr	Design Eng
Bruno Recaldini	Sunny
Date: 02-Dec-14	Date: 02-Dec-14

TABLE OF CONTENTS

1	MAIN FEATURES	4
2	MECHANICAL SPECIFICATION	5
2.1	MECHANICAL CHARACTERISTICS.....	5
2.2	MECHANICAL DRAWING.....	6
3	ELECTRICAL SPECIFICATION	7
3.1	ABSOLUTE MAXIMUM RATINGS.....	7
3.2	ELECTRICAL CHARACTERISTICS.....	8
3.3	INTERFACE PIN ASSIGNMENT	9
3.4	BLOCK DIAGRAM	10
3.5	TIMING CHARACTERISTICS	11
3.6	PIXEL DATA FOMAT	12
3.7	POWER SEQUENCE	13
4	OPTICAL SPECIFICATION	14
4.1	OPTICAL CHARACTERISTICS	14
5	BACKLIGHT SPECIFICATION	16
5.1	LED INTERFACE PIN ASSIGNMENT	16
5.2	PARAMETER GUIDELINE OF LED BACKLIGHT	16
6	QUALITY ASSURANCE SPECIFICATION	17
6.1	DELIVERY INSPECTION STANDARDS	17
6.2	DEALING WITH CUSTOMER COMPLAINTS.....	23
7	RELIABILITY SPECIFICATION	24
7.1	RELIABILITY TESTS.....	24
8	HANDLING PRECAUTIONS	25

REVISION RECORD

Rev.	Date	Page	Chapt.	Comment	ECN no.
1.0	02-Jan-14			Initial Release	

1 MAIN FEATURES

ITEM	CONTENTS
Screen Size	7" Diagonal
Display Format	1024 x RGB x 600 Dots
N° of Colour	16.7M
Overall Dimensions	170 mm (H) x 105.2 mm (V) x 11.2 mm (D)
Active Area	153.6 mm (H) x 90.0 mm (V)
LCD Type	TFT
Mode	Transmissive / Normally White
Viewing Direction	Full view
Electrical Interface	LVDS
Backlight Type	LED
Operating Temperature	-30°C ~ +85°C
Storage Temperature	-40°C ~ +95°C
RoHS compliant	Yes

2 MECHANICAL SPECIFICATION

2.1 MECHANICAL CHARACTERISTICS

ITEM	CHARACTERISTIC	UNIT
Display Format	1024 x RGB x 600 Dots	Dots
Overall Dimensions	170 (H) x 105.2 (V) x 11.2 (D)	mm
Active Area	153.6 (H) x 90.0 (V)	mm
pixel Pitch	0.15 (H) x 0.15 (V)	mm
Weight	250 (MAX)	g

2.2 MECHANICAL DRAWING

Fig1: Reference outline drawing: Front side

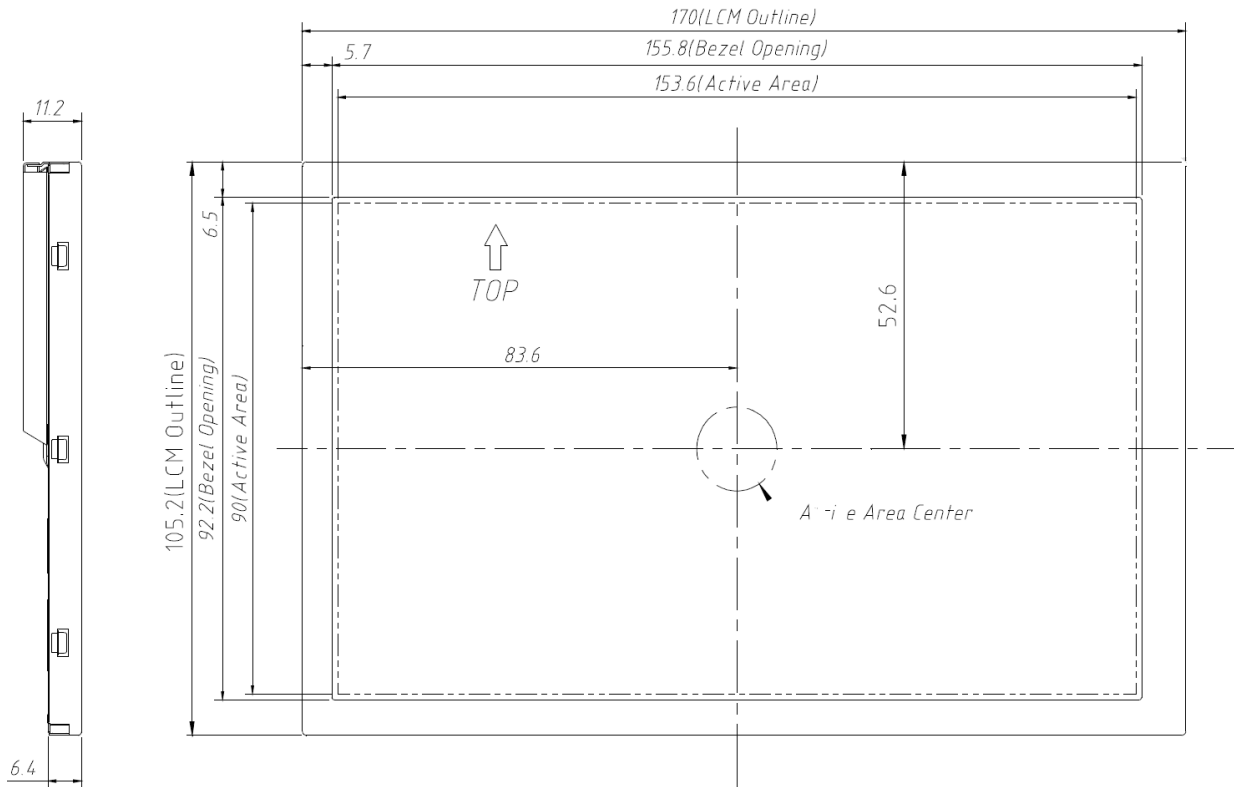
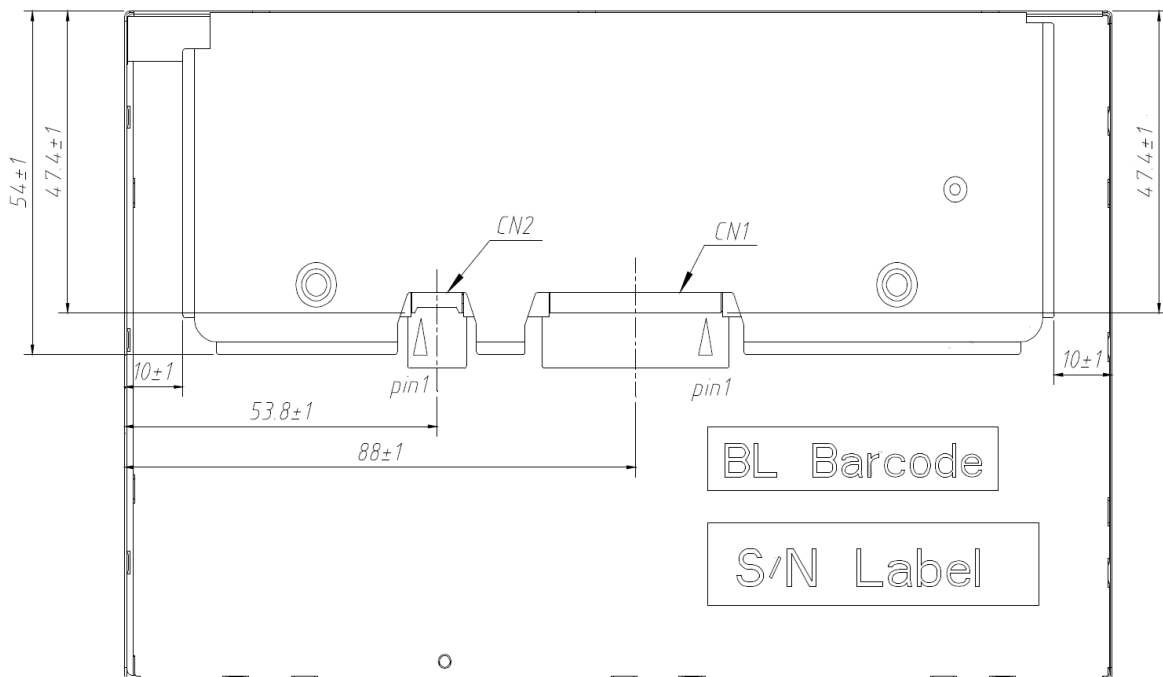

Fig2: Reference outline drawing: Back side



3 ELECTRICAL SPECIFICATION

3.1 ABSOLUTE MAXIMUM RATINGS

Item	Symbol	Condition	Min	Max	Unit	Note
Operating Temperature	TOP		-30	85	°C	1
Storage Temperature	TST		-40	95	°C	1,2,3
Operating Humidity	HOP		10	85	%RH	4
Storage Humidity	HST		10	95	%RH	4
Supply Voltage	V _{IN}	Logic	3.0	3.6	V	5
	V _{LED}	LED Driver Vin	8	16		
Power Supply Fuse current Setting	I _{fuse}	Vin from 10% to 90%, rise time 500us	-	1.5	A	
PWM voltage	V _{PWM}	PWM Dimming voltage	0.8	5.0	V	

Please make sure to keep the temperature of LCD module is less than 80°C

Note 1. 90 % RH Max for Ta<50 °C, and 60% RH for Ta≥50°C.

Note 2. In case of below 0°C, the response time of liquid crystal (LC) becomes slower and the colour of panel becomes darker than normal one. Level of retardation depends on temperature, because of LC's characteristic.

Note 3. Only operation is guaranteed at operating temperature. Contrast, response time, another display quality are evaluated at +25°C.

Note 4. Storage Range & Operating Range Picture:

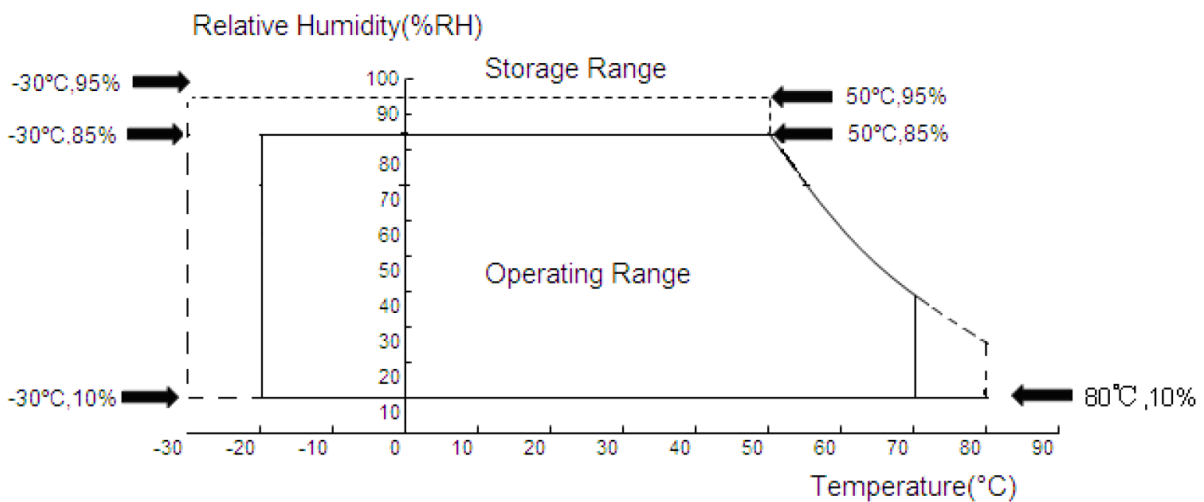

Fig5: Storage Range & Operating Range Picture

Note 5. Humidity: 85%RH MAX (T<40°C) Note static electricity. Maximum wet bulb temperature at 39°C or less. (T>40°C) No condensation.

3.2 ELECTRICAL CHARACTERISTICS

ITEM	SYMBOL	MIN.	TYP.	MAX.	UNIT	CONDITIONS
System Power Supply						
Input Power Supply Voltage	V _{IN}	3	3.3	3.6	V	
Input Power Supply Current	I _{VIN}	-	-	(153)	mA	V _{IN} =3.3V,Black pattern,60Hz
Input Inrush Current	I _{RUSH}	-	-	1.5	A	0.5ms rise time (10%~90%)
Input Power Voltage Ripple	VRPL	-	-	200	mV	V _{p-p}
LED Power Supply						
Input Power Supply Voltage	V _{LED_IN}	8	12	16	V	DUTY=100%
Input Power Supply Current	I _{VLED_IN}	-	-	(543)	mA	
EN/PWM	V _{IH}	(-2)	-	(5)	V	
	V _{IL}	(0)	-	-0.8	V	
LVDS Signals						
Differential Input High Threshold	V _{th}	-	-	+100	mV	V _{cm} =+1.2V
Differential Input Low Threshold	V _{tl}	-100	-	-	mV	V _{cm} =+1.2V
Magnitude Differential Input Voltage	V _{id}	200	-	600	mV	
Common Mode Voltage	V _{cm}	1	1.2	1.4	V	V _{th} -V _{tl} = 200mV
Common Mode Voltage Offset	ΔV _{cm}	-50	-	50	mV	V _{th} -V _{tl} = 200mV

Note A: Input signals shall be low or Hi-Z state when V_{IN} is off.

Note B: All electrical characteristics for LVDS signal are defined and shall be measured at the surface connector of LCD.

Note C: White Pattern at 3.3V driving voltage.

3.3 INTERFACE PIN ASSIGNMENT

Item: FDP Down Connector (20 pin pitch=1.25mm)

Connector recommended model: MSB240420HD

Pin #	Signal Name	Description	Remarks
1	VDD	LCD power supply (Typ. +3.3V)	
2	VDD	LCD power supply (Typ. +3.3V)	
3	VSS	Ground	
4	REV	Revers Scan Selection	
5	Rin1-	-LVDS differential data input	
6	Rin1+	+LVDS differential data input	
7	VSS	Ground	
8	Rin2-	-LVDS differential data input	
9	Rin2+	+LVDS differential data input	
10	VSS	Ground	
11	Rin3-	-LVDS differential data input	
12	Rin3+	+LVDS differential data input	
13	VSS	GND	
14	ClkIN-	-LVDS differential clock input	
15	ClkIN+	+LVDS differential clock input	
16	GND	GND	
17	Rin4-	-LVDS differential data input	
18	Rin4+	+LVDS differential data input	
19	VSS	Ground	
20	NC	Internal use	High Active

3.4 BLOCK DIAGRAM

It shows the functional block diagram of the LED module.

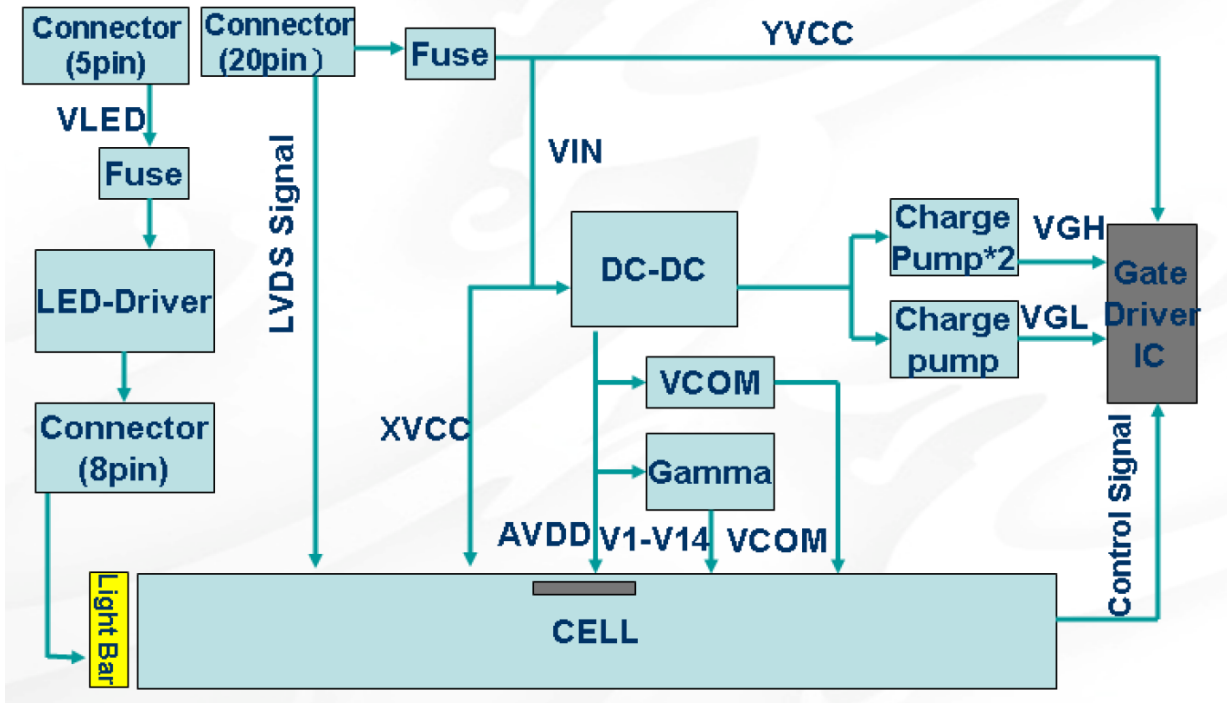

Fig4: Block Diagram

3.5 TIMING CHARACTERISTICS

3.5.1 Interface timings

Synchronization Method: DE only

Parameter	Symbol	Unit	Min.	Typ.	Max.
LVDS Clock Frequency <single >	fdck	MHz	45	51.2	57
H Total Time	Thp	clocks	1324	1344	1364
H Active Time	HA	clocks	1024	1024	1024
H Blanking Time	THBLANK	clocks	300	320	340
V Total Time	Tvp	lines	625	635	645
V Active Time	VA	lines	600	600	600
V Blanking Time	TVBLANK	lines	25	35	45
V Frequency	fv	Hz	55	60	65

Note: H Blanking Time and V Blanking Time can not be changed at every frame

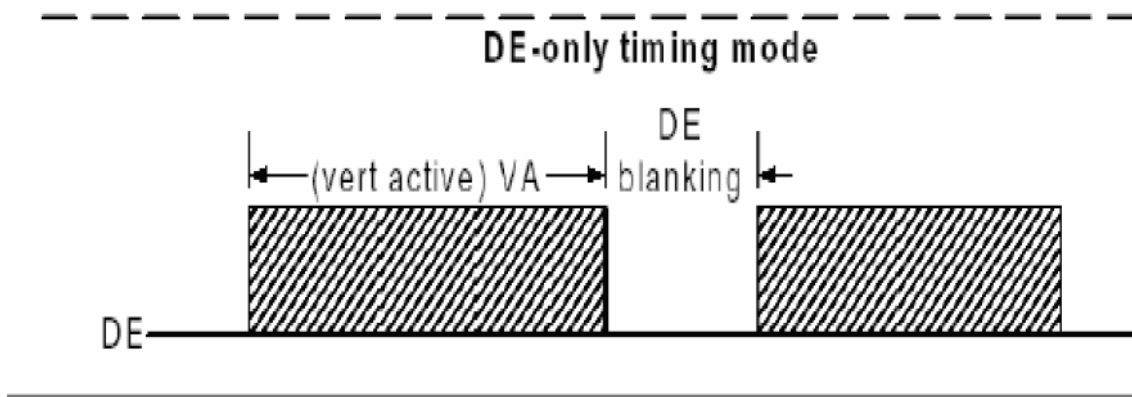
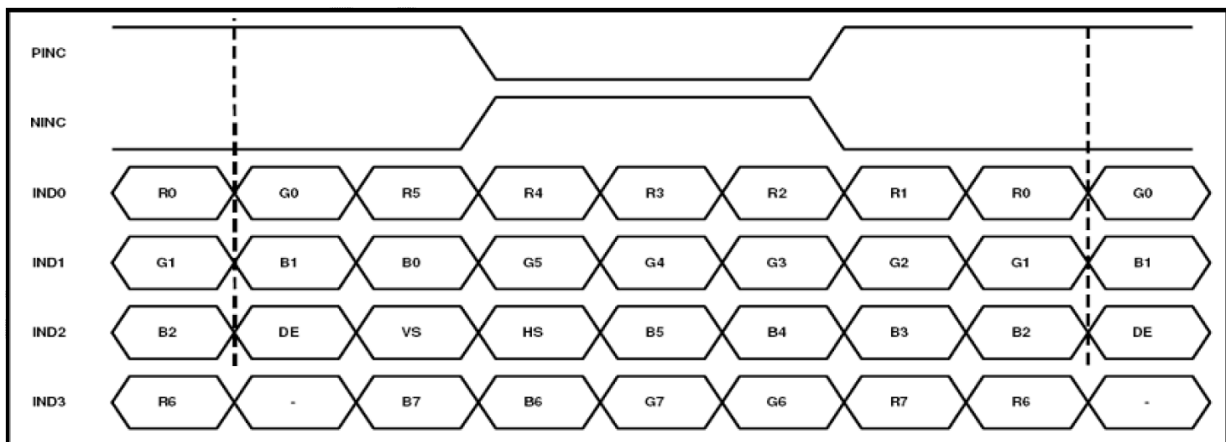

Fig 5: DE-only timing mode

3.4.2 Timing Diagram of Interface Signal

Fig6: LVDS Data Mapping



3.6 PIXEL DATA FOMAT

Fig3: Pixel Format

REV=L

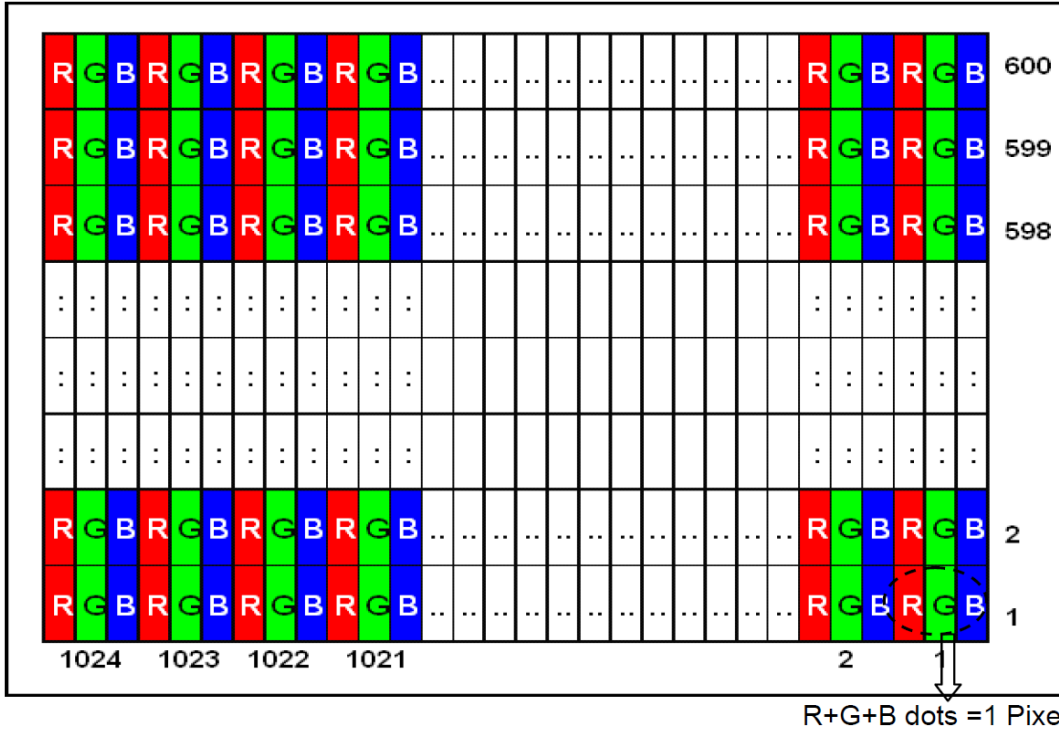

REV=H

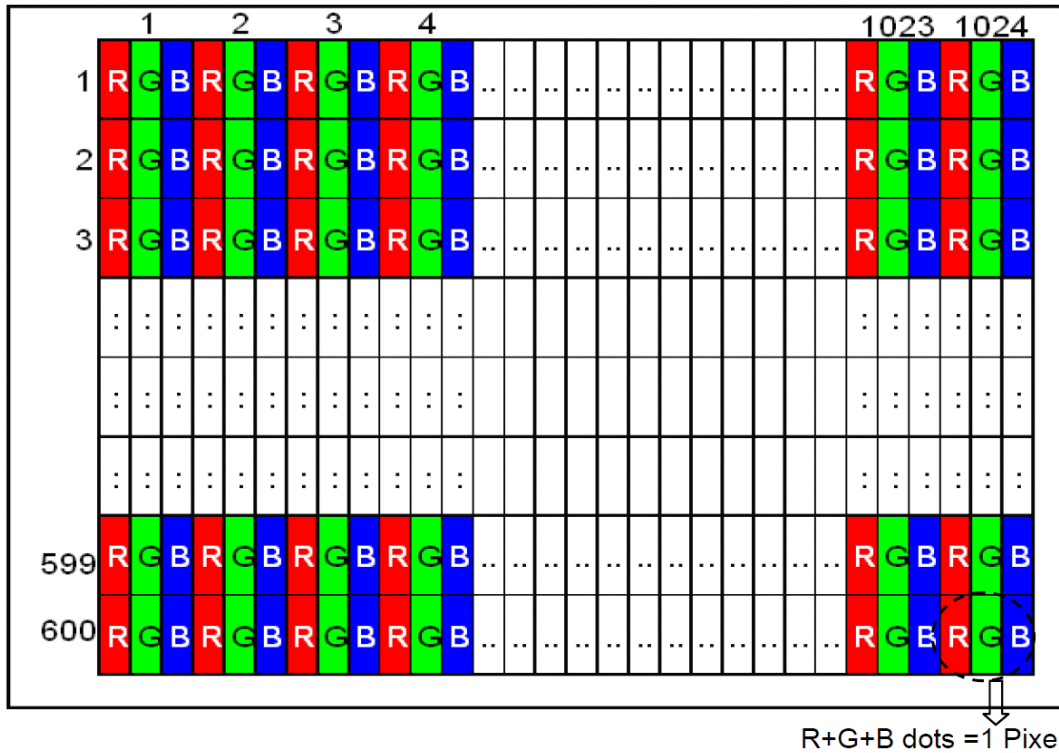

3.7 POWER SEQUENCE

Power ON/OFF Sequence

VDD power on/off sequence is as follows. Signals from any system shall be Hi-resistance state or low level when VDD is off. Interface signals are also shown in the chart.

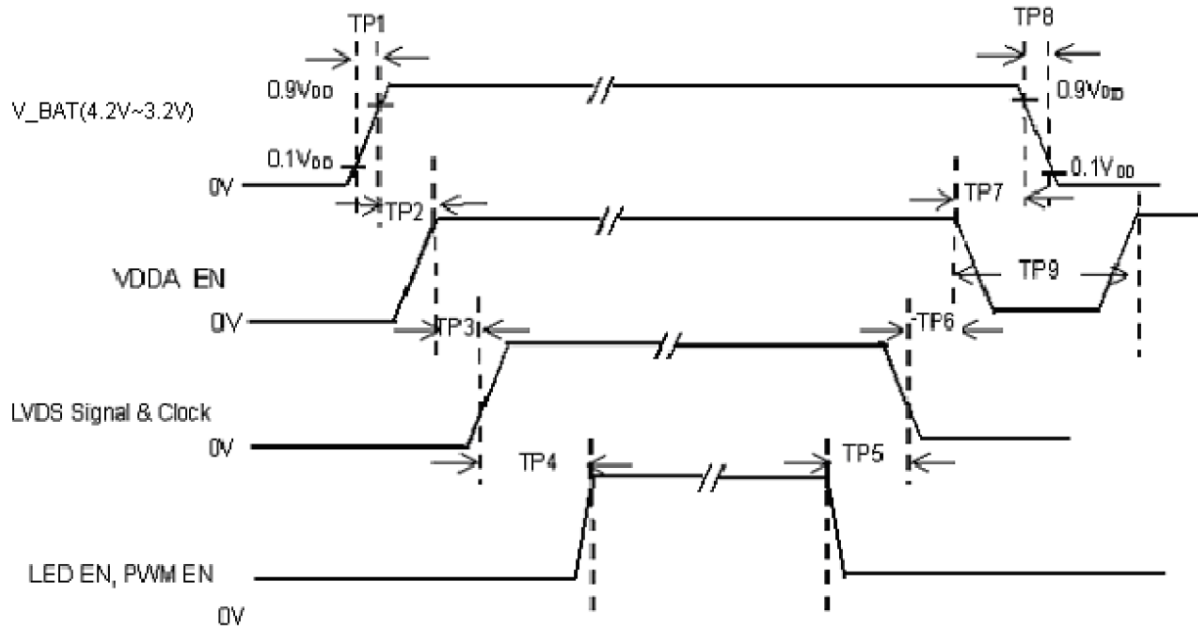

Fig 7: Power Sequencing

Table: Power sequence Requirement

Symbol	Unit	min	Typ.	Max	Remark
TP1	ms	0.5	-	10	-
TP2	ms	10	-	-	-
TP3	ms	30	40	90	-
TP4	ms	200	-	-	-
TP5	ms	110	-	-	-
TP6	ms	0	16	80	-
TP7	ms	0	-	-	Must exceed 0
TP8	ms	-	10	30	-
TP9	ms	1000	-	-	-

4 OPTICAL SPECIFICATION

4.1 OPTICAL CHARACTERISTICS

Driving condition: IOVCC = VCI = 2.8V, VSS = 0V
 Backlight: I_LED=240 mA, V_LED=12V, PWM_LED: Duty 100%
 Measured temperature: Ta = 25° C

Item	Symbol	Condition	MIN	TYP	MAX	Unit	Note			
Response Time	TR+TF	$\theta=\phi=0^\circ$ Normal Viewing Angle	-	TBD	-	ms	2			
Contrast Ratio	CR		700	800	-		3			
Viewing Angle	Left	CR ≥ 10	70	80	-	deg	4			
	Right		70	80	-	deg				
	Up		70	80	-	deg				
	Down		70	80	-	deg				
Colour Chromaticity	Red	Rx	CR ≥ 10	Typ.- 0.03	Typ.+0.0 3	-	5			
		Ry				-				
	Green	Gx				TBD		-		
		Gy				TBD		-		
	Blue	Bx				TBD		-		
		By				TBD		-		
	White	Wx				0.255		0.305	0.355	-
		Wy				0.275		0.325	0.375	-
Centre Brightness		centre	400	500	-	cd/m ²	6			
Brightness Distribution		9 Points	80	85	-	%	7			

Note: Measurement Setup:

The LCD module should be stabilized at given temperature (25°C) for 15 minutes to avoid abrupt temperature change during measuring. In order to stabilize the luminance, the measurement should be executed after lighting backlight 15 minutes in a windless room.

Test Method

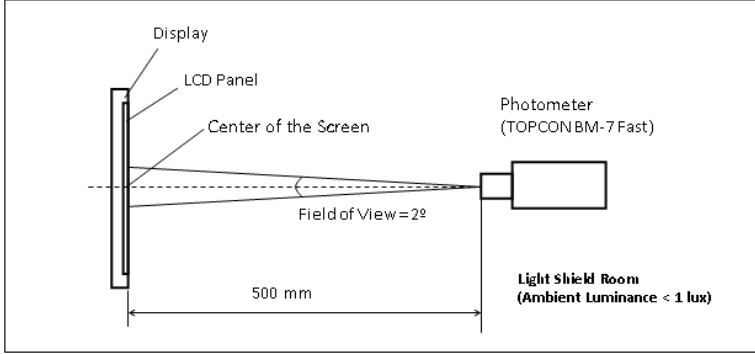
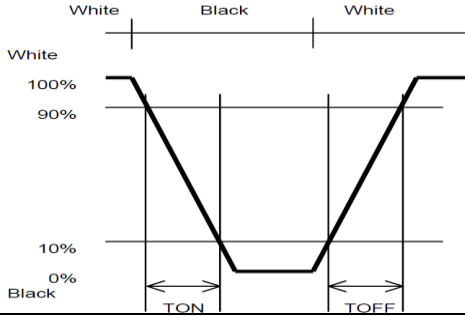
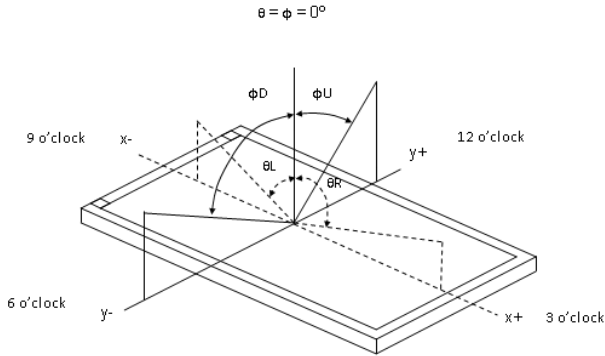
Note	Item	Test method
1	Setup	<p>The display should be stabilised at a given temperature for 30 minutes to avoid abrupt temperature change during measuring. In order to stabilise the luminance, measurements should be executed after lighting the backlight for 30 minutes in a windless room.</p> 
2	Response time	<p>Measure output signal waveform by the luminance meter when raster of window pattern is changed from white to black and from black to white.</p> 
3	Contrast ratio	<p>Measure maximum brightness and minimum brightness at the centre of the screen by displaying raster or window pattern. Then calculate the ratio between these two values.</p> $\text{Contrast Ratio (CR)} = \frac{\text{Brightness of unselected position (white)}}{\text{Brightness of selected position (black)}}$
4	Viewing angle Horizontal θ Vertical ϕ	<p>Move the luminance meter from right to left and up and down and determinate the angles where contrast ratio is 10</p> 
5	Colour chromaticity	Measure chromaticity coordinates x and y of CIE1931 colorimetric system
6	Centre brightness	Measure the brightness at the centre of the screen
7	Brightness distribution	<p>(Brightness distribution)= 100 x B/A % A: max. brightness of the 9 points B: min. brightness of the 9 points</p>

5 BACKLIGHT SPECIFICATION

5.1 LED INTERFACE PIN ASSIGNMENT

Connector mode: MSB24038P5A or compatible

Manufactured: STM or compatible

Mating model number: P24038P5A or compatible

Pin #	Signal Name	Description	Remarks
1	VCC	Power Supply, 12V (typical)	
2	GND	Ground	
3	EN	3.3V (typical)	
4	PWM	3.3V (typical)	
5	NC	Not Connection	

5.2 PARAMETER GUIDELINE OF LED BACKLIGHT

ITEM		Min.	Typ.	Max.	Units	Condition
VIN_VLED		8	12	14	V	Duty=100%
IVIN_LED		-	-	543	mA	
FDIM		100	-	1k	Hz	
DUTY		5	-	100	%	
CTRL	VIH	2	3.3	5	V	
	VIL	0	-	0.8		
Vout		-	(23.1)	(25.2)	V	
Iout		-	(160)	-	mA	
Efficiency		(80)				
LT		50,000	-	-	Hours	LED Life Time

Note1: The LED life time define as the estimated time to 50% degradation of initial luminous.

Note2: Operating temperature 25°C, humidity 55% RH

6 QUALITY ASSURANCE SPECIFICATION

6.1 DELIVERY INSPECTION STANDARDS

Inspection Conditions

Inspection distance: 30 cm ± 2 cm
Viewing angle: ±45°

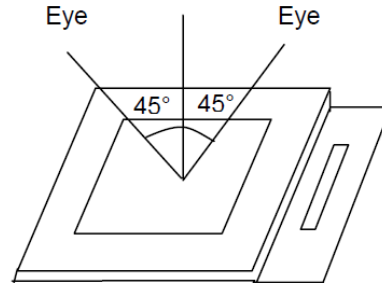

Environmental Conditions

Ambient temperature: 23°C ±5°C
Ambient humidity: 55±10% RH
Ambient illumination: 1000~1500 lux

Sampling Conditions

1. Lot size: quantity of shipment lot per model
2. Sampling method:

Sampling Plan		ANSI / ASQC Z1.4-1993
		Normal inspection, Single Sampling
AQL	Major Defect	0.65%
	Minor Defect	1.5%

Definition of Area

A zone: active area
B zone: viewing area

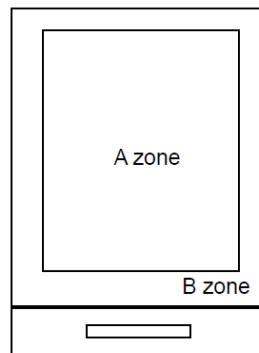

Basic Principle

A set of sample to indicate the limit of acceptable quality level shall be discussed should a dispute occur.

Inspection Criteria

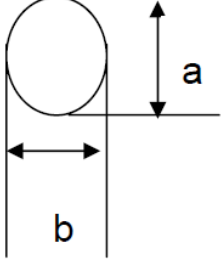
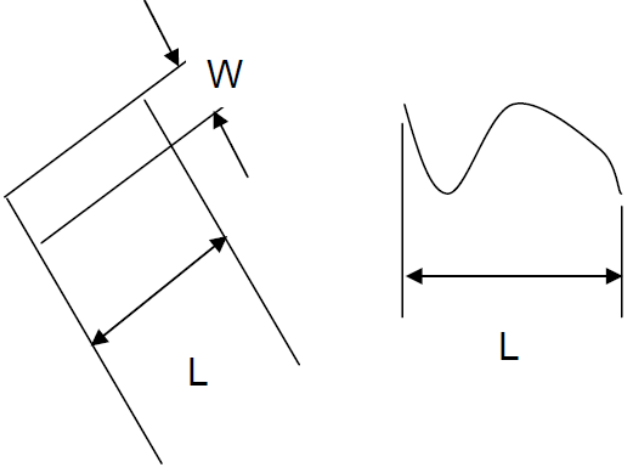
No.	Item	Criteria (Unit: mm)																		
01	Black / White spot Foreign material (Round type) Pinholes Stain Particles inside cell. (Minor defect)	 <table border="1" data-bbox="858 443 1380 801"> <thead> <tr> <th>Size</th> <th>Area</th> <th>Acc. Qty</th> </tr> </thead> <tbody> <tr> <td>$\phi \leq 0.10$</td> <td></td> <td>Ignore</td> </tr> <tr> <td>$0.10 < \phi \leq 0.15$</td> <td></td> <td>2</td> </tr> <tr> <td>$0.15 < \phi \leq 0.25$</td> <td></td> <td>1</td> </tr> <tr> <td>$0.25 < \phi$</td> <td></td> <td>0</td> </tr> <tr> <td>Total</td> <td></td> <td>2 no include $\phi \leq 0.10$</td> </tr> </tbody> </table> <p>$\phi = (a + b) / 2$</p> <p>Distance between 2 defects should more than 3mm apart.</p>	Size	Area	Acc. Qty	$\phi \leq 0.10$		Ignore	$0.10 < \phi \leq 0.15$		2	$0.15 < \phi \leq 0.25$		1	$0.25 < \phi$		0	Total		2 no include $\phi \leq 0.10$
Size	Area	Acc. Qty																		
$\phi \leq 0.10$		Ignore																		
$0.10 < \phi \leq 0.15$		2																		
$0.15 < \phi \leq 0.25$		1																		
$0.25 < \phi$		0																		
Total		2 no include $\phi \leq 0.10$																		
02	Black and White line Scratch Foreign material (Line type) (Minor defect)																			

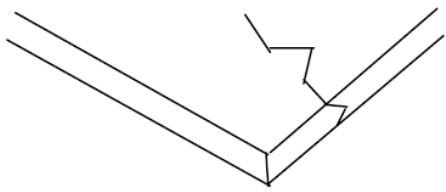
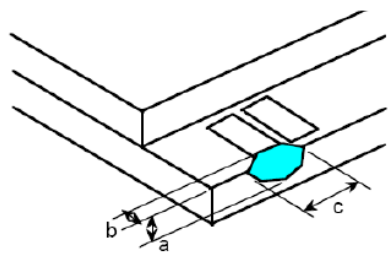
		<table border="1"> <thead> <tr> <th>Length</th> <th>Width</th> <th>Acc. Qty</th> </tr> </thead> <tbody> <tr> <td>/</td> <td>$W \leq 0.03$</td> <td>Ignore</td> </tr> <tr> <td>$L \leq 2.5$</td> <td>$0.03 < W \leq 0.05$</td> <td>3</td> </tr> <tr> <td>$L \leq 2.5$</td> <td>$0.05 < W \leq 0.10$</td> <td>2</td> </tr> <tr> <td>/</td> <td>$0.1 < W$</td> <td>0</td> </tr> <tr> <td colspan="2">Total</td> <td>3</td> </tr> </tbody> </table> <p>Distance between 2 defects should more than 3mm apart. Scratches not viewable through the back of the display are acceptable.</p>	Length	Width	Acc. Qty	/	$W \leq 0.03$	Ignore	$L \leq 2.5$	$0.03 < W \leq 0.05$	3	$L \leq 2.5$	$0.05 < W \leq 0.10$	2	/	$0.1 < W$	0	Total		3
Length	Width	Acc. Qty																		
/	$W \leq 0.03$	Ignore																		
$L \leq 2.5$	$0.03 < W \leq 0.05$	3																		
$L \leq 2.5$	$0.05 < W \leq 0.10$	2																		
/	$0.1 < W$	0																		
Total		3																		
03	Glass Crack (Minor defect)	 <p>Crack is potential to enlarge, any type is not allowed.</p>																		
04	Glass Chipping Pad Area: (Minor defect)	 <table border="1"> <thead> <tr> <th>Length and Width</th> <th>Acc. Qty</th> </tr> </thead> <tbody> <tr> <td>$c > 3.0, b < 1.0$</td> <td>1</td> </tr> <tr> <td>$c < 3.0, b < 1.0$</td> <td>3</td> </tr> <tr> <td colspan="2">$a < \text{Glass Thickness}$</td> </tr> </tbody> </table>	Length and Width	Acc. Qty	$c > 3.0, b < 1.0$	1	$c < 3.0, b < 1.0$	3	$a < \text{Glass Thickness}$											
Length and Width	Acc. Qty																			
$c > 3.0, b < 1.0$	1																			
$c < 3.0, b < 1.0$	3																			
$a < \text{Glass Thickness}$																				

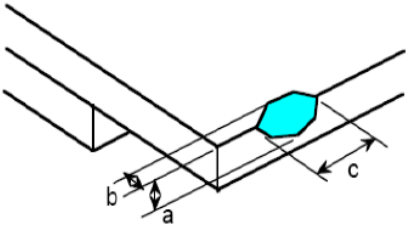
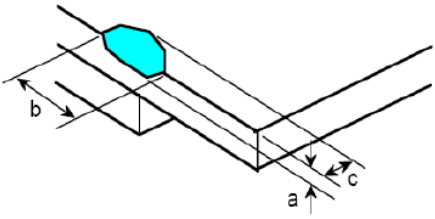
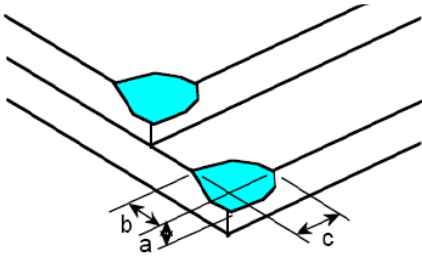
<p>05</p>	<p>Glass Chipping Rear of Pad Area: (Minor defect)</p> 	<table border="1"> <thead> <tr> <th>Length and Width</th> <th>Acc. Qty</th> </tr> </thead> <tbody> <tr> <td>$c > 3.0, b < 1.0$</td> <td>1</td> </tr> <tr> <td>$c < 3.0, b < 1.0$</td> <td>2</td> </tr> <tr> <td>$c < 3.0, b < 0.5$</td> <td>4</td> </tr> <tr> <td colspan="2" style="text-align: center;">$a < \text{Glass Thickness}$</td> </tr> </tbody> </table>	Length and Width	Acc. Qty	$c > 3.0, b < 1.0$	1	$c < 3.0, b < 1.0$	2	$c < 3.0, b < 0.5$	4	$a < \text{Glass Thickness}$	
Length and Width	Acc. Qty											
$c > 3.0, b < 1.0$	1											
$c < 3.0, b < 1.0$	2											
$c < 3.0, b < 0.5$	4											
$a < \text{Glass Thickness}$												
<p>06</p>	<p>Glass Chipping Except Pad Area: (Minor defect)</p> 	<table border="1"> <thead> <tr> <th>Length and Width</th> <th>Acc. Qty</th> </tr> </thead> <tbody> <tr> <td>$c > 3.0, b < 1.0$</td> <td>1</td> </tr> <tr> <td>$c < 3.0, b < 1.0$</td> <td>2</td> </tr> <tr> <td>$c < 3.0, b < 0.5$</td> <td>4</td> </tr> <tr> <td colspan="2" style="text-align: center;">$a < \text{Glass Thickness}$</td> </tr> </tbody> </table>	Length and Width	Acc. Qty	$c > 3.0, b < 1.0$	1	$c < 3.0, b < 1.0$	2	$c < 3.0, b < 0.5$	4	$a < \text{Glass Thickness}$	
Length and Width	Acc. Qty											
$c > 3.0, b < 1.0$	1											
$c < 3.0, b < 1.0$	2											
$c < 3.0, b < 0.5$	4											
$a < \text{Glass Thickness}$												
<p>07</p>	<p>Glass Corner Chipping: (Minor defect)</p> 	<table border="1"> <thead> <tr> <th>Length and Width</th> <th>Acc. Qty</th> </tr> </thead> <tbody> <tr> <td>$c < 3.0, b < 3.0$</td> <td>Ignore</td> </tr> <tr> <td colspan="2" style="text-align: center;">$a < \text{Glass Thickness}$</td> </tr> </tbody> </table>	Length and Width	Acc. Qty	$c < 3.0, b < 3.0$	Ignore	$a < \text{Glass Thickness}$					
Length and Width	Acc. Qty											
$c < 3.0, b < 3.0$	Ignore											
$a < \text{Glass Thickness}$												

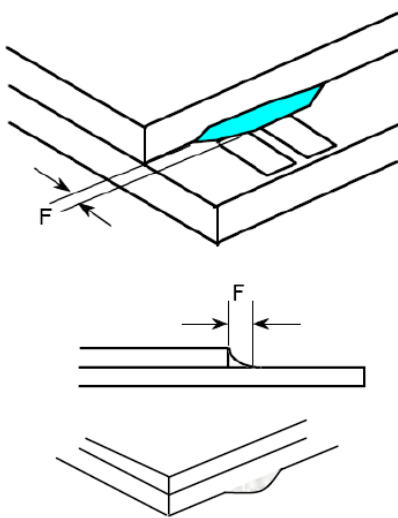
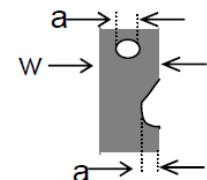
08	<p>Glass Burr: (Minor defect)</p> 	<table border="1" data-bbox="837 555 1305 645"> <thead> <tr> <th>Length</th> <th>Acc. Qty</th> </tr> </thead> <tbody> <tr> <td>$F < 1.0$</td> <td>Ignore</td> </tr> </tbody> </table> <p>Glass burr don't affect assemble and module dimension.</p>	Length	Acc. Qty	$F < 1.0$	Ignore				
Length	Acc. Qty									
$F < 1.0$	Ignore									
09	<p>FPC Defect: (Minor defect)</p> 	<p>9.1 Dent, pinhole width $a < w/3$. (w: circuitry width.)</p> <p>9.2 Open circuit is unacceptable.</p> <p>9.3 No oxidation, contamination and distortion.</p>								
10	<p>Bubble on Polarizer (Minor defect)</p>	<table border="1" data-bbox="715 1438 1182 1610"> <thead> <tr> <th>Diameter</th> <th>Acc. Qty</th> </tr> </thead> <tbody> <tr> <td>$\varphi \leq 0.20$</td> <td>Ignore</td> </tr> <tr> <td>$0.20 < \varphi \leq 0.30$</td> <td>4</td> </tr> <tr> <td>$0.30 < \varphi$</td> <td>None</td> </tr> </tbody> </table>	Diameter	Acc. Qty	$\varphi \leq 0.20$	Ignore	$0.20 < \varphi \leq 0.30$	4	$0.30 < \varphi$	None
Diameter	Acc. Qty									
$\varphi \leq 0.20$	Ignore									
$0.20 < \varphi \leq 0.30$	4									
$0.30 < \varphi$	None									
11	<p>Dent on Polarizer (Minor defect)</p>	<table border="1" data-bbox="715 1680 1182 1852"> <thead> <tr> <th>Diameter</th> <th>Acc. Qty</th> </tr> </thead> <tbody> <tr> <td>$\varphi \leq 0.20$</td> <td>Ignore</td> </tr> <tr> <td>$0.20 < \varphi \leq 0.30$</td> <td>4</td> </tr> <tr> <td>$0.30 < \varphi$</td> <td>None</td> </tr> </tbody> </table>	Diameter	Acc. Qty	$\varphi \leq 0.20$	Ignore	$0.20 < \varphi \leq 0.30$	4	$0.30 < \varphi$	None
Diameter	Acc. Qty									
$\varphi \leq 0.20$	Ignore									
$0.20 < \varphi \leq 0.30$	4									
$0.30 < \varphi$	None									
12	<p>Bezel</p>	<p>12.1 No rust, distortion on the Bezel.</p> <p>12.2 No visible fingerprints, stains or other contamination.</p>								

13	Touch Panel	<p>D: Diameter W: width L: length</p> <p>13.1 Spot: $D < 0.25$ is acceptable $0.25 \leq D \leq 0.4$</p> <p>2dots are acceptable and the distance between defects should more than 10 mm. $D > 0.4$ is unacceptable</p> <p>13.2 Dent: $D > 0.40$ is unacceptable</p> <p>13.3 Scratch: $W \leq 0.03$, $L \leq 10$ is acceptable, $0.03 < W \leq 0.10$, $L \leq 10$ is acceptable</p> <p>Distance between 2 defects should more than 10 mm. $W > 0.10$ is unacceptable.</p>
14	PCB	<p>14.1 No distortion or contamination on PCB terminals.</p> <p>14.2 All components on PCB must same as documented on the BOM/component layout.</p> <p>14.3 Follow IPC-A-600F.</p>
15	Soldering	Follow IPC-A-610C standard
16	Electrical Defect (Major defect)	<p>The below defects must be rejected.</p> <p>16.1 Missing vertical / horizontal segment,</p> <p>16.2 Abnormal Display.</p> <p>16.3 No function or no display.</p> <p>16.4 Current exceeds product specifications.</p> <p>16.5 LCD viewing angle defect.</p> <p>16.6 No Backlight.</p> <p>16.7 Dark Backlight.</p> <p>16.8 Touch Panel no function.</p> <p>16.9 Dark Dot –one Allowed.</p> <p>16.10 Bright Dot – one Allowed.</p> <p>Remark:</p> <p>1. A pixel defect is acceptable if one color is none functional and causes a bright dot. The display may have one case where one color is out and cause a dark dot.</p> <p>2. Bright dot caused by scratch and foreign object accords to item 1.</p>

Remark: LCD Panel Broken shall be rejected. Defect out of LCD viewing area is acceptable.

Classification of Defects

Visual defects (except no or wrong label) are treated as minor defects, while electrical defects are treated as major defects.

Two minor defects are equal to one major defect in lot sampling inspection.

Identification / marking criteria

Any unit with illegible / wrong / double or no marking / label shall be rejected.

6.2 DEALING WITH CUSTOMER COMPLAINTS

Non-conforming analysis

Purchaser should supply Densitron with detailed data of non-conforming sample.

After accepting it, Densitron should complete the analysis in two weeks from receiving the sample.

If the analysis cannot be completed on time, Densitron must inform the purchaser.

Handling of non-conforming displays

If any non-conforming displays are found during customer acceptance inspection which Densitron is clearly responsible for, return them to Densitron.

Both Densitron and customer should analyse the reason and discuss the handling of non-conforming displays when the reason is not clear.

Equally, both sides should discuss and come to agreement for issues pertaining to modification of Densitron quality assurance standard.

7 RELIABILITY SPECIFICATION

7.1 RELIABILITY TESTS

Test Item		Test Condition
Durability Test	High Temperature Storage	Ta= 80°C 96h
	Low Temperature Storage	Ta=-30°C 96h
	Temperature Cycle Storage	-20°C for 30 min, then 70°C for 30 min, 20 cycles
	High Temperature Operation	Tp= 70°C 96h
	Low Temperature Operation	Tp= -20°C 96h
	High Temperature & Humidity Operation	Tp= 40°C RH= 90% 96h Non condensing
	Thermal Shock Resistance	The sample should be allowed to stand the following 5 cycles of operation: TSTL for 30 minutes -> normal temperature for 5 minutes -> TSTH for 30 minutes -> normal temperature for 5 minutes, as one cycle, then taking it out and drying it at normal temperature, and allowing it stand for 24 hours

Note: Ta=ambient temperature Tp= Panel temperature

Notes:

1. No dew condensation to be observed.
2. The function test shall be conducted after 4 hours storage at the normal temperature and humidity after removed from the test chamber.
3. No cosmetic or functional defects should be allowed.
4. Total current consumption should be less than twice the initial value.

8 HANDLING PRECAUTIONS

Safety

If the LCD panel breaks, be careful not to get the liquid crystal fluid in your mouth or in your eyes. If the liquid crystal touches your skin or clothes, wash it off immediately using soap and plenty of water.

Mounting and Design

Place a transparent plate (e.g. acrylic, polycarbonate or glass) on the display surface to protect the display from external pressure. Leave a small gap between the transparent plate and the display surface.

When assembling with a zebra connector, clean the surface of the pads with alcohol and keep the surrounding air very clean.

Design the system so that no input signal is given unless the power supply voltage is applied.

Caution during LCD cleaning

Lightly wipe the display surface with a soft cloth soaked with Isopropyl alcohol, Ethyl alcohol or Trichlorotrifluoroethane.

Do not wipe the display surface with dry or hard materials that will damage the polariser surface. Do not use aromatic solvents (toluene and xylene), or ketonic solvents (ketone and acetone).

Caution against static charge

As the display uses C-MOS LSI drivers, connect any unused input terminal to VDD or VSS. Do not input any signals before power is turned on. Also, ground your body, work/assembly table and assembly equipment to protect against static electricity.

Packaging

Displays use LCD elements, and must be treated as such. Avoid strong shock and drop from a height. To prevent displays from degradation, do not operate or store them exposed directly to sunshine or high temperature/humidity.

Caution during operation

It is indispensable to drive the display within the specified voltage limit since excessive voltage shortens its life. Direct current causes an electrochemical reaction with remarkable deterioration of the display quality. Give careful consideration to prevent direct current during ON/OFF timing and during operation. Response time is extremely delayed at temperatures lower than the operating temperature range while, at high temperatures, displays become dark. However, this phenomenon is reversible and does not mean a malfunction or a display that has been permanently damaged. If the display area is pushed on hard during operation, some graphics will be abnormally displayed but returns to a normal condition after turning off the display once. Even a small amount of condensation on the contact pads (terminals) can cause an electro-chemical reaction which causes missing rows and columns. Give careful attention to avoid condensation.

Storage

Store the display in a dark place where the temperature is 25°C ± 10°C and the humidity below 50%RH. Store the display in a clean environment, free from dust, organic solvents and corrosive gases.

Do not crash, shake or jolt the display (including accessories).

Product No.	DET070WSNLNTOM-2A	REV. 1.0
-------------	-------------------	----------

Page	25 / 25
------	---------