

OLED DISPLAY MODULE

Product Specification

CUSTOMER	Standard	
PRODUCT NUMBER	DD-2C20BE-1A	
CUSTOMER APPROVAL		

INTERNAL APPROVALS		
Product Mgr	Doc. Control	Electr. Eng
Richard Applin	Richard Applin	Alan Wang
Date: 16 -July -13	Date: 16-July-13	Date: 16-July-13

TABLE OF CONTENTS

1	MAIN FEATURES	4
2	MECHANICAL SPECIFICATION	5
2.1	MECHANICAL CHARACTERISTICS	5
2.2	MECHANICAL DRAWING	6
3	ELECTRICAL SPECIFICATION.....	7
3.1	ABSOLUTE MAXIMUM RATINGS	7
3.2	ELECTRICAL CHARACTERISTICS	8
3.3	INTERFACE PIN ASSIGNMENT	9
3.4	BLOCK DIAGRAM	12
3.5	TIMING CHARACTERISTICS	14
4	OPTICAL SPECIFICATION.....	19
4.1	OPTICAL CHARACTERISTICS	19
5	FUNCTIONAL SPECIFICATION	20
5.1	COMMANDS	20
5.2	POWER UP/DOWN SEQUENCE.....	20
5.3	RESET CIRCUIT	21
5.4	ACTUAL APPLICATION EXAMPLE	22
5.5	BUILD-IN CGROM (CHARACTER GENERATOR ROM)	26
5.6	SELF-DEFINED CGRAM (CHARACTER GENERATOR RAM)	29
6	PACKAGING AND LABELLING SPECIFICATION.....	30
7	QUALITY ASSURANCE SPECIFICATION.....	31
7.1	CONFORMITY	31
7.2	DELIVERY ASSURANCE	31
7.3	DEALING WITH CUSTOMER COMPLAINTS	37
8	RELIABILITY SPECIFICATION	38
8.1	RELIABILITY TESTS	38
8.2	LIFE TIME	38
9	HANDLING PRECAUTIONS.....	39
9.1	HANDLING PRECAUTIONS	39
9.2	STORAGE PRECAUTIONS	40
9.3	DESIGNING PRECAUTIONS.....	40
9.4	OTHER PRECAUTIONS	41
10	SUPPORTED ACCESSORIES	42
10.1	DUO KIT.....	42
10.1	TRANSITION BOARD CARD	42
10.2	CONNECTOR BOARD CARD.....	42
10.3	CONNECTOR	42
10.4	APPLICATION NOTES AND EXAMPLE CODES	42

Product No.	DD-2C20BE-1A	REV. A

Page	2 / 42
------	--------

REVISION RECORD

Rev.	Date	Page	Chapt.	Comment	ECR no.
A	16 July 13			First Issue	

Product No.	DD-2C20BE-1A	REV. A

Page	3 / 42
------	--------

1 MAIN FEATURES

ITEM	CONTENTS
Characters x lines	20 x 2
Character Font	5 x 8
Overall Dimensions	84.50 x 19.28 x 2.00 mm
Colour	Monochrome Blue
Active Area	73.52 x 11.52 mm
Viewing Area	75.52 x 13.52 mm
Display Mode	Passive Matrix (2.93")
Driving Method	1/16 duty
Driver IC	US2066
Operating temperature	-40 ~ +85
Storage temperature	-40 ~ +90

Product No.	DD-2C20BE-1A	REV. A

Page	4 / 42
------	--------

2 MECHANICAL SPECIFICATION

2.1 MECHANICAL CHARACTERISTICS

ITEM	CHARACTERISTIC	UNIT
Characters x lines	20 x 2	
Overall Dimensions	84.50 x 19.28 x 2.00	mm
Viewing Area	75.52 x 13.52	mm
Active Area	73.52 x 11.52	mm
Dot Size	0.62 x 0.67	mm
Dot Pitch	0.65 x 0.70	mm
Character size	3.22 x 5.57	mm
Weight	7.01	g
IC Controller/Driver	US2066	

Product No.	DD-2C20BE-1A	REV. A

Page	5 / 42
------	--------

2.2 MECHANICAL DRAWING

Item	Date	Remark
A	20110627	Original Drawing
B	20111220	Modify Protective Tape Size
C	20120206	Add Double Side Tape On FPC

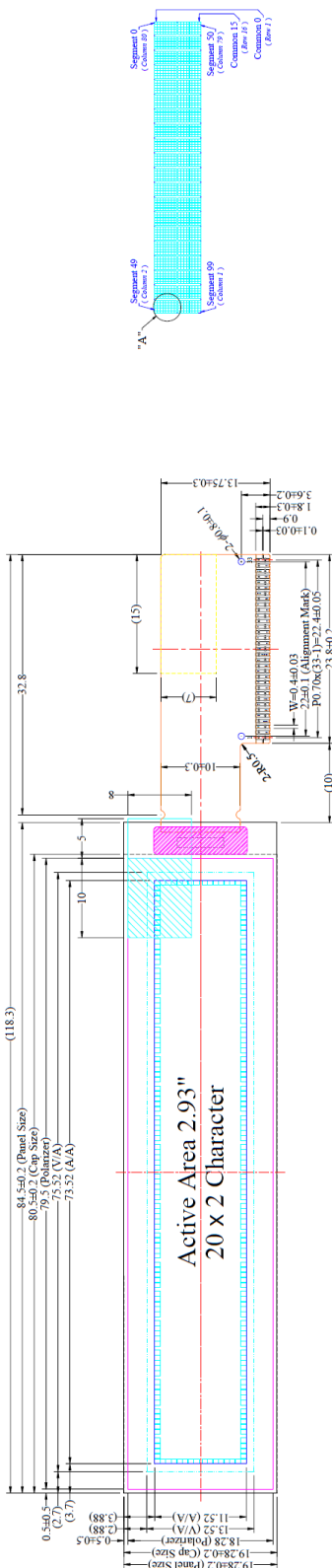

Pin	Symbol
1	N.C.
2	VSL
3	VSS
4	REFL
5	SHL
6	SHLS
7	VDD
8	VDD0
9	VDD1
10	B51
11	B52
12	GFD0
13	CS*
14	DC*
15	D.C.*
16	E-W(REF)
17	ERDM
18	D0
19	D1
20	D2
21	D3
22	D4
23	D5
24	D6
25	D7
26	REF
27	FR00
28	OPR0
29	OPR1
30	OPR2
31	VCOGHE
32	VCC
33	N.C.

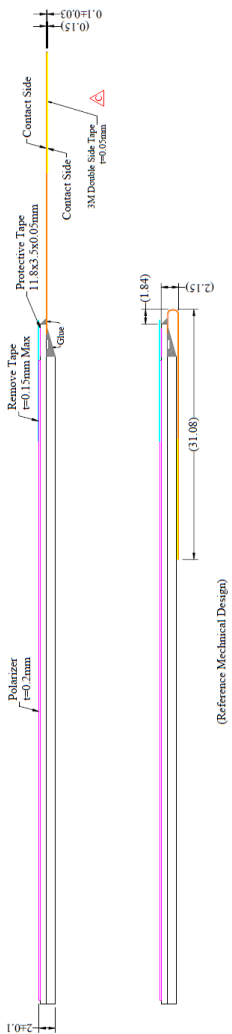
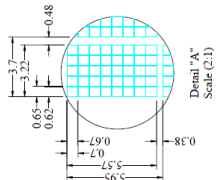

- Notes:
- Color: Light Blue
 - Driver IC: US2066
 - FPC Number: UT-0166-P01
 - Interface: 4-8-bit 68XX/80XX Parallel, SPI, I2C
 - General Tolerance: ±0.30
 - The total thickness (2.10 Max) is without polarizer protective film & remove tape. The actual assembled total thickness with above materials should be 2.35 Max.

Customer Approval		DENSI TRON DISPLAYS				REV.	
Signature	Unit	Title	Material	Sheet	Scale	Sheet	Size
	mm	DD-2C20BE-1A Folding Type OEL Display Module	Soda Lime / Polyimide	1 of 1	1:1	1 of 1	A3
	General Roughness	Pixel Number: Character 20 x 2, Monochrome, COG Package					
	Tolerance	Drawn	Panel / E.				
	Dimension	Gary Lin	Ting Kuo Hu	Ivy Lo	Kate Chung		
	Angle	±0.3	±1	20120206	20120206	20120206	

Product No.	DD-2C20BE-1A	REV. A
-------------	--------------	--------

Page	6 / 42
------	--------

3 ELECTRICAL SPECIFICATION

3.1 ABSOLUTE MAXIMUM RATINGS

VSS = 0 V, Ta = 25 °C

Item	Symbol	Min	Max	Unit	Note
Supply Voltage for logic	V _{DD}	-0.3	6.0	V	Note 1, 2
Supply Voltage for I/O Pins	V _{DDIO}	-0.3	6.0	V	
Supply voltage for Display	V _{CC}	0	15	V	
Operating Temperature	T _{op}	-40	85	°C	Note 3
Storage Temperature	T _{st}	-40	90	°C	Note 3

Note 1: All the above voltages are on the basis of “VSS=0V”.

Note 2: When this module is used beyond the above absolute maximum ratings, permanent damage to the module may occur. Also for normal operations it's desirable to use this module under the conditions according to Section 3.2 “Electrical Characteristics”. If this module is used beyond these conditions the module may malfunction and the reliability could deteriorate.

Note 3: The defined temperature ranges do not include the polarizer. The maximum withstood temperature of the polarizer should be 80°C.

3.2 ELECTRICAL CHARACTERISTICS

Characteristics	Symbol	Conditions	Min	Typ	Max	Unit
Supply Voltage for Logic	V_{DD}	5V I/O Application	-	-	-	V
		Low Voltage I/O Application	2.4	2.8	V_{DDIO}	V
Supply Voltage for I/O	V_{DDIO}	5V I/O Application	4.4	5.0	5.5	V
		Low Voltage I/O Application	2.4	2.8	3.6	V
Supply Voltage for Display	V_{CC}	Note 1	8.5	9	9.5	V
High Level Input	V_{IH}	$I_{OUT}=0.1mA,$ 3.3MHz	$0.8 \times V_{DDIO}$	-	V_{DDIO}	V
Low Level Input	V_{IL}		0	-	$0.2 \times V_{DDIO}$	V
High Level Output	V_{OH}	$I_{OUT}=0.1mA,$ 3.3MHz	$0.9 \times V_{DDIO}$	-	V_{DDIO}	V
Low Level Output	V_{OL}		0	-	$0.1 \times V_{DDIO}$	V
Operating current for V_{DD}	I_{DD}	-	-	180	300	μA
Operating current for V_{CC}	I_{CC}	Note 2	-	7.1	8.9	mA
		Note 3	-	10.5	13.1	
		Note 4	-	19.9	24.9	
Sleep mode current for V_{DD}	$I_{DD\ SLEEP}$		-	1	10	μA
Sleep mode current for V_{CC}	$I_{CC\ SLEEP}$		-	2	10	μA

Note 1: Brightness (Lbr) and Supply Voltage for Display (V_{CC}), are subject to the change of the panel characteristics

Note 2: $V_{DDIO} = 2.8V$ or $5.0V$, $V_{CC} = 9.0V$, 30% display area turned on.

Note 2: $V_{DDIO} = 2.8V$ or $5.0V$, $V_{CC} = 9.0V$, 50% display area turned on.

Note 4: $V_{DDIO} = 2.8V$ or $5.0V$, $V_{CC} = 9.0V$, 100% display area turned on.

Product No.	DD-2C20BE-1A	REV. A

Page	8 / 42
------	--------

3.3 INTERFACE PIN ASSIGNMENT

No.	Symbol	I/O	Function																
1	N.C.(GND)	-	Reserved Pin (Supporting Pin) The supporting pin can reduce the influence from stress on the function pins. This pin must be connected to external ground																
2	VSL	P	Segment Voltage Reference Pin When external VSL is not used, this pin should be left open. When external VSL is used, connect with resistor and diode to ground.																
3	VSS	P	Ground of Logic Circuit This is a ground pin. It also acts as a reference for the logic pins, the OEL driving voltages and the analogue circuits. It must be connected to external ground.																
4	REGVDD	I	Internal VDD Regulator Selection Pin When this pin is pulled HIGH, internal VDD regulator is enabled (VDD outputs 3.3V). When this pin is pulled LOW, internal VDD regulator is disabled (VDD outputs 5V).																
5	SHLC	I	COM Scan Direction Selection This pin is used to determine the Common output scanning direction <table border="1"> <tr> <th>SHLC</th> <th>COM scan direction</th> </tr> <tr> <td>0</td> <td>COM0 to COM31</td> </tr> <tr> <td>1</td> <td>COM31 to COM0</td> </tr> </table>	SHLC	COM scan direction	0	COM0 to COM31	1	COM31 to COM0										
SHLC	COM scan direction																		
0	COM0 to COM31																		
1	COM31 to COM0																		
6	SHLS	I	SEG Direction Selection This pin is used to determine the SEG direction <table border="1"> <tr> <th>SHLS</th> <th>SEG direction</th> </tr> <tr> <td>0</td> <td>SEG99 to SEG0</td> </tr> <tr> <td>1</td> <td>SEG0 to SEG99</td> </tr> </table>	SHLS	SEG direction	0	SEG99 to SEG0	1	SEG0 to SEG99										
SHLS	SEG direction																		
0	SEG99 to SEG0																		
1	SEG0 to SEG99																		
7	VDD	P	Power Supply for Logic This is a voltage supply pin. It can be supplied externally or regulated internally. In 3V IO mode, this is a power input pin. In 5V IO mode, the output is around 3.3V. A capacitor should be connected between VDD and VSS under all circumstances																
8	VDDIO	P	Power Supply for Interface Logic Level It should match with the MCU interface voltage level and must be connected to external source																
9	BS0	I	Communicating Protocol Select These pins are MCU interface selection input. See the following table: <table border="1"> <tr> <th></th> <th>BS0</th> <th>BS1</th> <th>BS2</th> </tr> <tr> <td>Serial Interface</td> <td>0</td> <td>0</td> <td>0</td> </tr> <tr> <td>Invalid</td> <td>1</td> <td>0</td> <td>0</td> </tr> <tr> <td>I2C</td> <td>0</td> <td>1</td> <td>0</td> </tr> </table>		BS0	BS1	BS2	Serial Interface	0	0	0	Invalid	1	0	0	I2C	0	1	0
	BS0			BS1	BS2														
Serial Interface	0	0	0																
Invalid	1	0	0																
I2C	0	1	0																
10	BS1																		

Product No.	DD-2C20BE-1A	REV. A

Page	9 / 42
------	--------

11	BS2		Invalid	1	1	0
			8 bit 68XX-parallel	0	0	1
			4 bit 68XX-parallel	1	0	1
			8 bit 80XX-parallel	0	1	1
			4 bit 80XX-parallel	1	1	1
12	GPIO	I/O	It is a reserved pin and is recommended to keep it floating.			
13	CS#	I	<p>Chip Select This pin is the chip select input. The chip is enabled for MCU communication only when CS# is pulled low.</p>			
14	RES#	I	<p>Power Reset for Controller and Driver This pin is reset signal input. When the pin is low, initialization of the chip is executed.</p>			
15	D/C#	I	<p>Data/Command Control This is Data/Command control pin. When the pin is pulled high, the input at D7~D0 is treated as display data. When the pin is pulled low, the input at D7~D0 will be transferred to the command register. For detail relationship to MCU interface signals, please refer to the Timing Characteristics Diagrams.</p> <p>When the pin is pulled high and serial interface mode is selected, the data at SDIN is treated as data. When it is pulled low the data at SDIN will be transferred to the command register. In I2C mode, this pin acts as SA0 for slave address selection.</p>			
16	R/W#	I	<p>Read/Write Select or Write This pin is MCU interface input. When interfacing to a 68XX-series microprocessor, this pin will be used as Read/Write (R/W#) selection input. Pull this pin to “High” for read mode and pull it to “Low” for write mode.</p> <p>When 80XX interface mode is selected, this pin will be the Write (WR#) input. Data write operation is initiated when this pin and the CS# are pulled low.</p>			
17	E/RD#	I	<p>Read/Write Enable or Read This pin is MCU interface input. When interfacing to a 68XX-series microprocessor, this pin will be used as the Enable (E) signal. Read/write operation is initiated when this pin is pulled high and the CS# is pulled low.</p> <p>When connecting to an 80XX-microprocessor, this pin receives the Read (RD#) signal. Data read operation is initiated when this pin is pulled low and CS# is pulled low.</p>			
18~25	D0~D7	I/O	<p>Host Data Input/Output Bus These pins are 8-bit bi-directional data bus to be connected to the microprocessor’s data bus. When serial mode is selected, D1 will be the serial data input SDIN and D0 will be the serial clock input SCLK. When I2C mode is selected, D2, D1 should be tied together and serve as SDAout, SDAin in application and D0 is the serial clock input SCL</p>			

Product No.	DD-2C20BE-1A	REV. A

Page	10 / 42
------	---------

26	IREF	I	<p>Current Reference for Brightness Adjustment</p> <p>This pin is segment current reference pin. A resistor should be connected between this pin and VSS. Set the current at 12.5uA.</p>																				
27	ROM0	I	<p>Character ROM Selection</p> <p>These pins are used to select Character ROM. See the following table:</p> <table border="1"> <thead> <tr> <th>ROM</th> <th>ROM0</th> <th>ROM1</th> </tr> </thead> <tbody> <tr> <td>A</td> <td>0</td> <td>0</td> </tr> <tr> <td>B</td> <td>1</td> <td>0</td> </tr> <tr> <td>C</td> <td>0</td> <td>1</td> </tr> <tr> <td>S/W selectable</td> <td>1</td> <td>1</td> </tr> </tbody> </table>	ROM	ROM0	ROM1	A	0	0	B	1	0	C	0	1	S/W selectable	1	1					
ROM	ROM0			ROM1																			
A	0			0																			
B	1			0																			
C	0	1																					
S/W selectable	1	1																					
28	ROM1																						
29	OPR0	I	<p>Select the number of Character Generator</p> <p>These pins are used to select Character number of character generator. See the following table:</p> <table border="1"> <thead> <tr> <th>CGROM</th> <th>CGRAM</th> <th>OPR0</th> <th>OPR1</th> </tr> </thead> <tbody> <tr> <td>256</td> <td>0</td> <td>1</td> <td>1</td> </tr> <tr> <td>248</td> <td>8</td> <td>1</td> <td>0</td> </tr> <tr> <td>250</td> <td>6</td> <td>0</td> <td>1</td> </tr> <tr> <td>240</td> <td>8</td> <td>0</td> <td>0</td> </tr> </tbody> </table>	CGROM	CGRAM	OPR0	OPR1	256	0	1	1	248	8	1	0	250	6	0	1	240	8	0	0
CGROM	CGRAM			OPR0	OPR1																		
256	0			1	1																		
248	8			1	0																		
250	6	0	1																				
240	8	0	0																				
30	OPR1																						
31	VCOMH	O	<p>Voltage Output High Level for COM Signal</p> <p>This pin is the input pin for the voltage output high level for COM signals. A capacitor should be connected between this pin and VSS.</p>																				
32	VCC	P	<p>Power Supply for OEL Panel</p> <p>This is the most positive voltage supply pin of the chip. A stabilization capacitor should be connected between this pin and VSS when the converter is used. It must be supplied externally.</p>																				
33	N.C.	-	<p>Reserved Pin (Supporting Pin)</p> <p>The supporting pin can reduce the influence from stress on the function pins. This pin must be connected to external ground</p>																				

Product No.	DD-2C20BE-1A	REV. A

Page	11 / 42
------	---------

3.4 BLOCK DIAGRAM

3.4.1 Low Voltage I/O Application

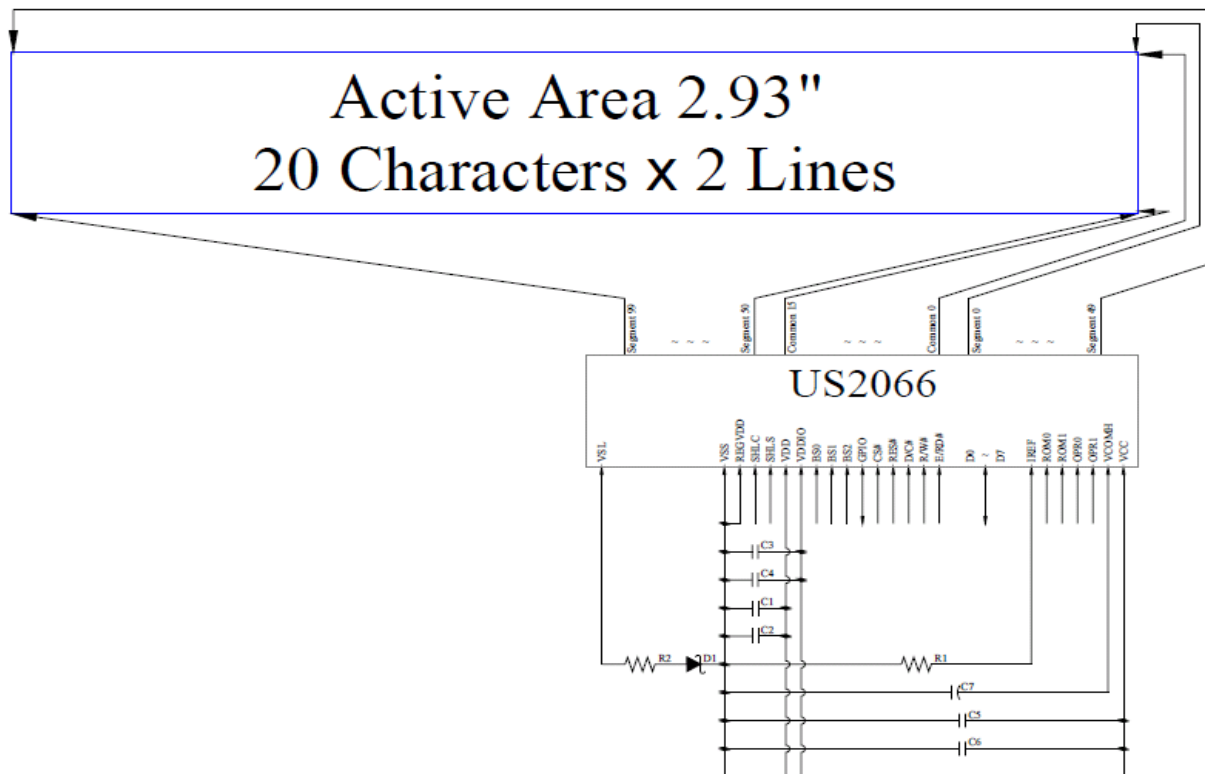

MCU Interface Selection: BS0, BS1 and BS2
 Pins connected to MCU interface: CS#, RES#, D/C#, R/W#, E/RD#, and D0~D7
 * SHLC, SHLC, ROM0, ROM1, OPR0 and OPR1 should be configured.

- C1, C3, C5: 0.1µF
- C2, C4: 4.7µF
- C6: 10µF
- C7: 4.7µF / 25V Tantalum Capacitor
- R1: 470kΩ, $R1 = (\text{Voltage at IREF} - VSS) / IREF$
- R2: 50Ω, 1/4W
- D1: ≤1.4V, 0.5W

Product No.	DD-2C20BE-1A	REV. A

Page	12 / 42
------	---------

3.4.2 5V I/O Application

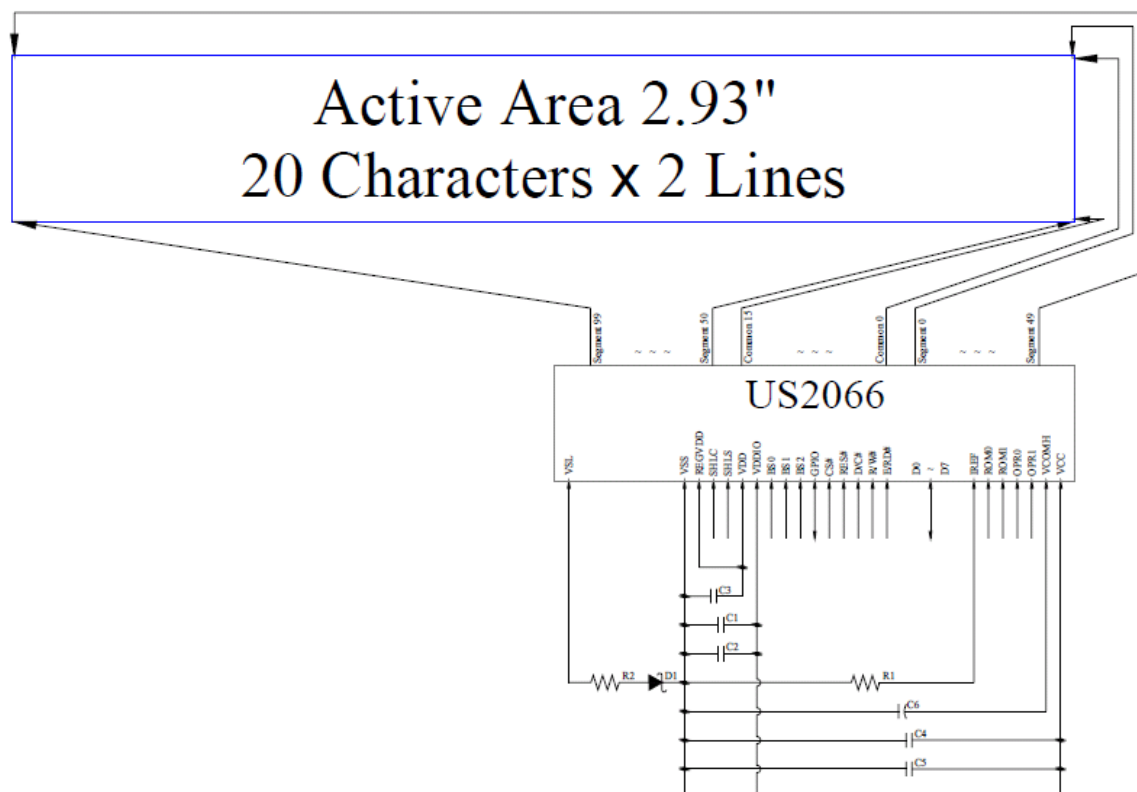

MCU Interface Selection: BS0, BS1 and BS2
 Pins connected to MCU interface: CS#, RES#, D/C#, R/W#, E/RD#, and D0~D7
 * SHLC, SHLC, ROM0, ROM1, OPR0 and OPR1 should be configured.

- C1, C4: 0.1µF
- C2: 4.7µF
- C3: 1µF
- C5: 10µF
- C6: 4.7µF / 25V Tantalum Capacitor
- R1: 470kΩ, $R1 = (\text{Voltage at IREF} - VSS) / IREF$
- R2: 50Ω, 1/4W
- D1: ≤1.4V, 0.5W

Product No.	DD-2C20BE-1A	REV. A

Page	13 / 42
------	---------

3.5 TIMING CHARACTERISTICS

3.5.1 AC CHARACTERISTICS

3.5.1.1 68XX-Series MPU Parallel Interface Timing Characteristics

VDDIO-VSS = 2.4V to 3.6V/4.4V to 5.5V, Ta = 25°C

Symbol	Description	Min	Max	Unit
t _{cycle}	System Cycle Time	400	-	ns
t _{AS}	Address Setup Time	13	-	ns
t _{AH}	Address Hold Time	17	-	ns
t _{DSW}	Write Data Setup Time	35	-	ns
t _{DHW}	Write Data Hold Time	18	-	ns
t _{DHR}	Read Data Hold Time	13	-	ns
t _{OH}	Output Disable Time	10	90	ns
t _{ACC}	Access Time (RAM)	-	125	ns
	Access Time (Command)			
t _{CS}	Chip Select Time	0	-	ns
t _{CH}	Chip Select Hold Time	0	-	ns
PW _{CSL}	Chip Select Low Pulse Width (Read RAM)	250	-	ns
	Chip Select Low Pulse Width (Read Command)	250		
	Low Pulse width (Write)	50		
PW _{CSH}	Chip Select High Pulse Width (Read) Chip Select	155	-	ns
	High Pulse Width (Write)	55		
t _R	Rise Time	-	15	ns
t _F	Fall Time	-	15	ns

Product No.	DD-2C20BE-1A	REV. A

Page	14 / 42
------	---------

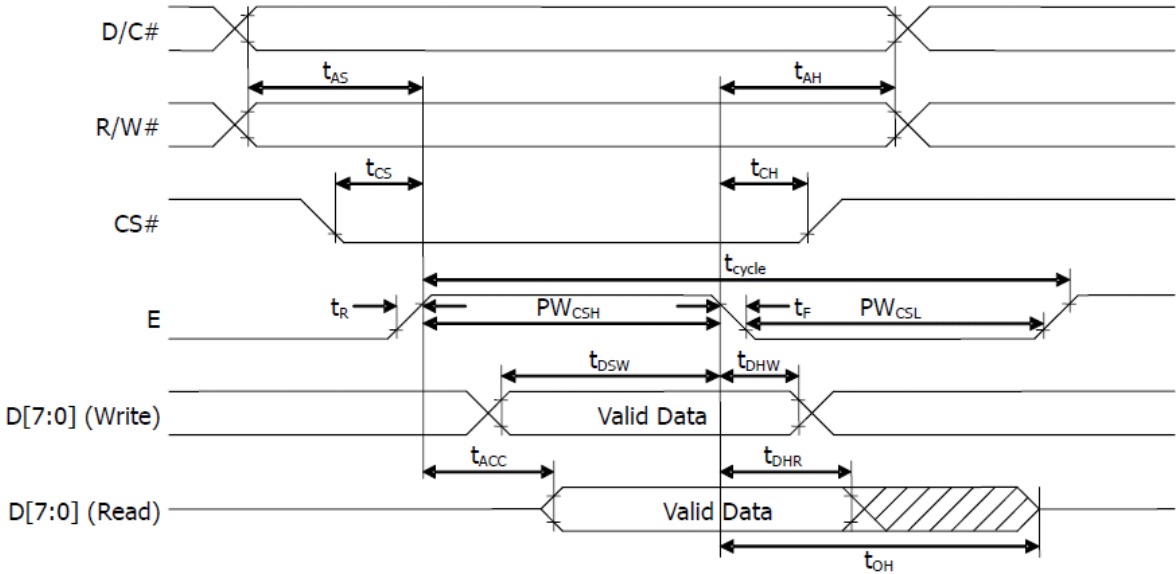

(CS# "Low Pulse Width" > E "High Pulse Width")

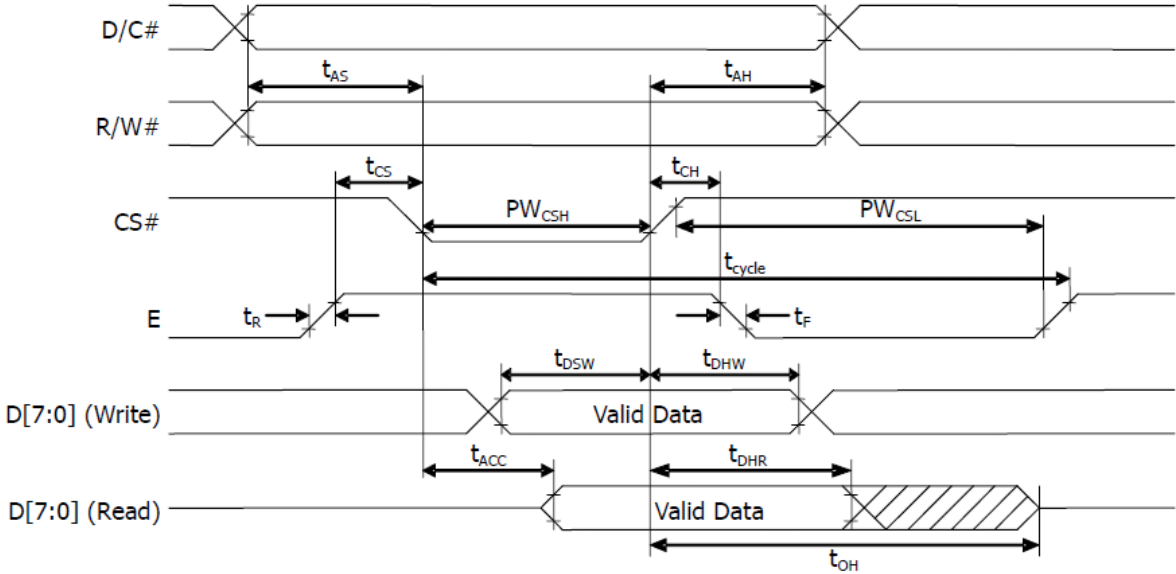

(CS# "Low Pulse Width" < E "High Pulse Width")

Product No.	DD-2C20BE-1A	REV. A

Page	15 / 42
------	---------

3.5.1.2 8080-Series MPU Parallel Interface Timing Characteristics

VDDIO-VSS = 2.4V to 3.6V/4.4V to 5.5V, Ta = 25°C

Symbol	Description	Min	Max	Unit
t _{cycle}	System Cycle Time	400	-	ns
t _{AS}	Address Setup Time	13	-	ns
t _{AH}	Address Hold Time	17	-	ns
t _{DSW}	Write Data Setup Time	35	-	ns
t _{DHW}	Write Data Hold Time	18	-	ns
t _{DHR}	Read Data Hold Time	13	-	ns
t _{OH}	Output Disable Time	10	70	ns
t _{ACC}	Access Time (RAM)	-	125	ns
	Access Time (Command)			
t _{CS}	Chip Select Time	0	-	ns
t _{CSH}	Chip Select Hold Time to Read Signal	0	-	ns
t _{CSF}	Chip Select Hold Time	0	-	ns
PW _{CSL}	Chip Select Low Pulse Width (Read RAM)- t _{PWLR}	250	-	ns
	Chip Select Low Pulse Width (Read Command)- t _{PWLR}	250		
	Low Pulse width (Write)- t _{PWLW}	50		
PW _{CSH}	Chip Select High Pulse Width (Read)- t _{PWHR}	155	-	ns
	High Pulse Width (Write)- t _{PWHW}	55		
t _R	Rise Time	-	15	ns
t _F	Fall Time	-	15	ns

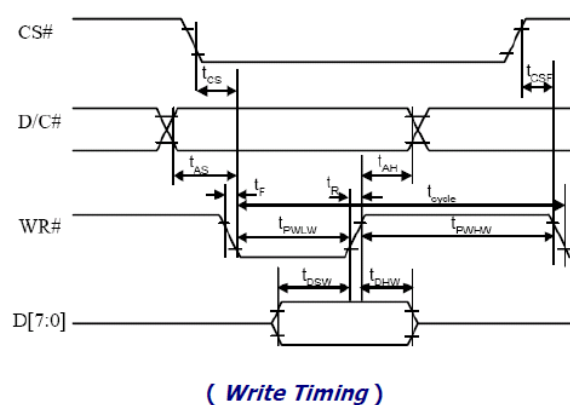
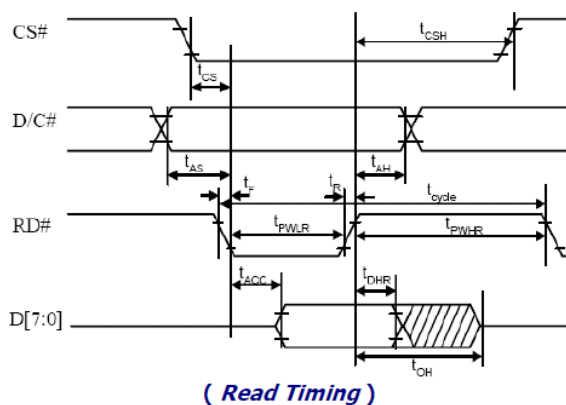

Product No.	DD-2C20BE-1A	REV. A

Page	16 / 42
------	---------

3.5.1.3 Serial Interface Timing Characteristics

VDDIO-VSS = 2.4V to 3.6V/4.4V to 5.5V, Ta = 25°C

Symbol	Description	Min	Max	Unit
t _{cycle}	Serial Clock Cycle Time	1	20	ns
t _{su1}	Chip Select Setup Time	60	-	ns
t _{h1}	Chip Select Hold Time	20	-	ns
t _{su2}	Serial Input Data Setup Time	200	-	ns
t _{h2}	Serial Input Data Hold Time	TBD	-	ns
t _D	Serial Output Data Delay Time	-	TBD	ns
t _{DH}	Serial Output Data Hold Time	10	-	ns
t _w	Serial Clock Width (Low, High)	400	-	ns
t _R	Rise Time	-	15	ns
t _F	Fall Time	-	15	ns

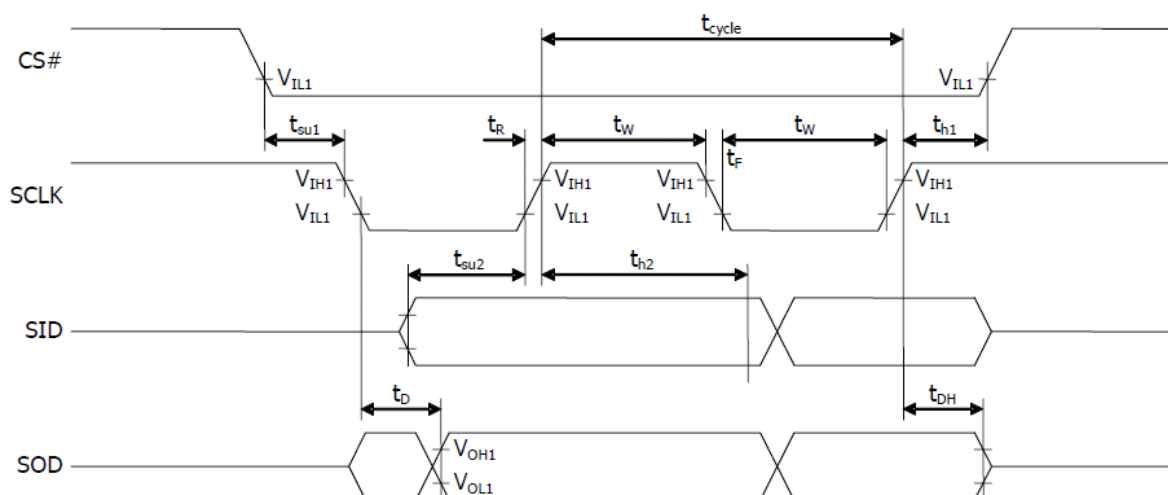

3.5.1.4 I²C Interface Timing Characteristics

VDDIO-VSS = 2.4V to 3.6V/4.4V to 5.5V, Ta = 25°C

Symbol	Description	Min	Max	Unit
t _{cycle}	Clock Cycle Time	2.5	-	us
t _{HSTART}	Start Condition Hold Time	0.6	-	us
t _{HD}	Data Hold Time (for “SDAOUT” Pin) Data	5	-	ns
	Hold Time (for “SDAIN” Pin)	300		
t _{SD}	Data Setup Time	100	-	ns
t _{SSTART}	Start Condition Setup Time (Only relevant for a repeated Start condition)	0.6	-	us
t _{SSTOP}	Stop Condition Setup Time	0.6	-	us
t _R	Rise Time for Data and Clock Pin		300	ns
t _F	Fall Time for Data and Clock Pin		300	ns
t _{IDLE}	Idle Time before a New Transmission can Start	1.3	-	us

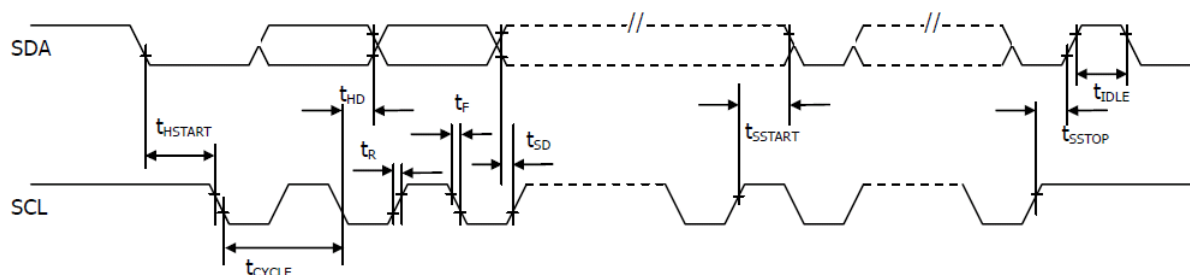

Product No.	DD-2C20BE-1A	REV. A

Page	18 / 42
------	---------

4 OPTICAL SPECIFICATION

4.1 OPTICAL CHARACTERISTICS

Characteristics	Symbol	Condition	Min	Typ	Max	Unit
Brightness	L _{br}	Note 1	60	80	-	cd/m ²
C.I.E.(Blue)	(X)	C.I.E. 1931	0.12	0.16	0.20	-
	(Y)		0.22	0.26	0.30	
Dark Room Contrast	CR		-	>10,000:1	-	-
Viewing Angle			-	Free	-	degree

Optical measurement taken at V_{DD} = 2.8V or 5.0V, V_{CC} = 9.0V.

Software configuration follows Section 5.4 Actual Application Example

Note 1 Brightness (L_{br}) and Supply Voltage for Display (V_{CC}) are subject to the change of the panel characteristics and the customers request.

Product No.	DD-2C20BE-1A	REV. A

Page	19 / 42
------	---------

5 FUNCTIONAL SPECIFICATION

5.1 COMMANDS

Please refer to the Technical Manual for the US2066

5.2 POWER UP/DOWN SEQUENCE

To protect panel and extend the panel lifetime, the driver IC power up/down routine should include a delay period between high voltage and low voltage power sources during turn on/off. It gives the panel enough time to complete the action of charge and discharge before/after the operation.

5.2.1 POWER UP SEQUENCE

1. Power up V_{DD} and V_{DDIO}
2. Send Display off command
3. Initialization
4. Clear Screen
5. Power up V_{CC}
6. Delay 100ms
(When V_{CC} is stable)
7. Send Display on command

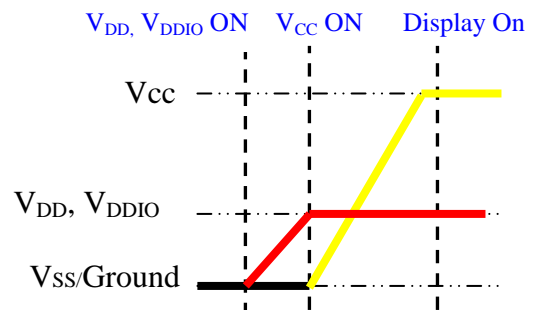

5.2.2 POWER DOWN SEQUENCE

1. Send Display off command
2. Power down V_{CC}
3. Delay 100ms
(When V_{CC} reaches 0 and panel is completely discharged)
4. Power down V_{DD} and V_{DDIO}

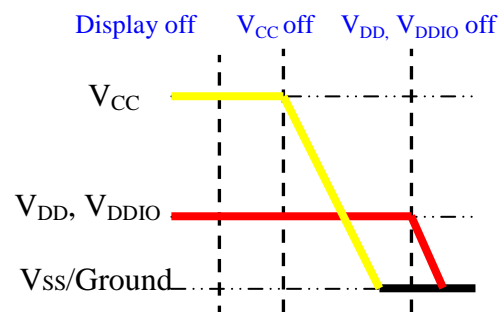

Conditions:

- 1) Since an ESD protection circuit is connected between V_{DD} , V_{DDIO} and V_{CC} inside the driver IC, V_{CC} becomes lower than V_{DD} & V_{DDIO} whenever V_{DD} & V_{DDIO} is ON and V_{CC} is OFF.
- 2) V_{CC} should be kept float (disable) when it is OFF.
- 3) Power Pins (V_{DD} , V_{DDIO} , V_{CC}) can never be pulled to ground under any circumstance.
- 4) V_{DD} & V_{DDIO} should not be power down before V_{CC} power down.

Product No.	DD-2C20BE-1A	REV. A
-------------	--------------	--------

Page	20 / 42
------	---------

5.3 RESET CIRCUIT

When RES# input is low, the chip is initialized with the following status:

1. Display is off
2. 5X8 Character Mode
3. Display start position is set at display RAM address 0
4. CGRAM address counter is set at 0
5. Cursor is OFF
6. Blink is OFF
7. Contrast control register is set at 7FH
8. OLED command set is disabled

Product No.	DD-2C20BE-1A	REV. A

Page	21 / 42
------	---------

5.4 ACTUAL APPLICATION EXAMPLE

Command usage and explanation of an actual example

5.4.1 Low Voltage I/O Application

<Power up Sequence>

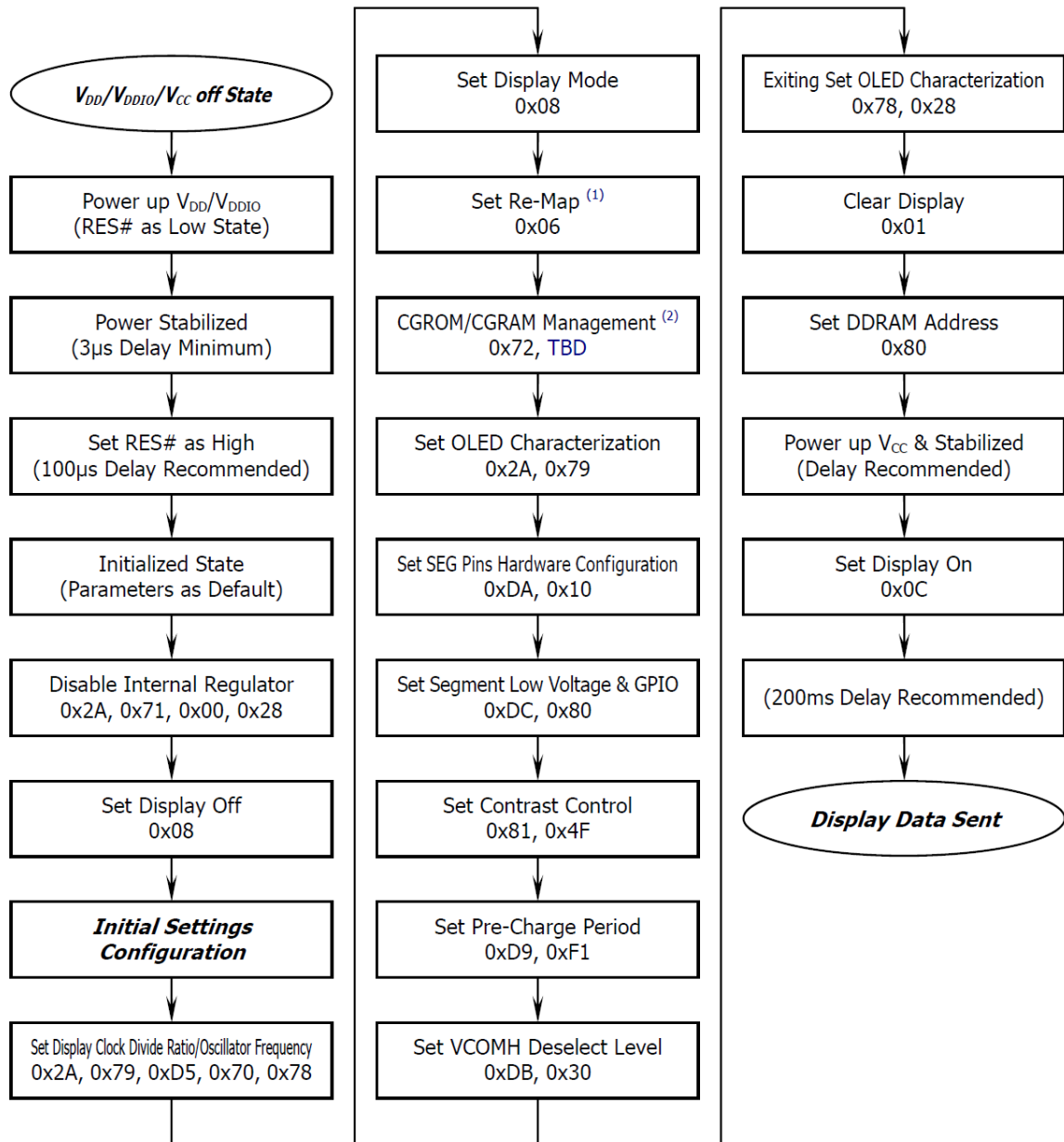

(1) This command could be programmable or defined by pin configuration.

(2) This command could be programmable or defined by pin configuration. The written value of the parameter should depend on the selection from section 5.5 and 5.6

If the noise is accidentally occurred at the displaying window during the operation, please reset the display in order to recover the display function.

Product No.	DD-2C20BE-1A	REV. A

Page	22 / 42
------	---------

<Power down Sequence>

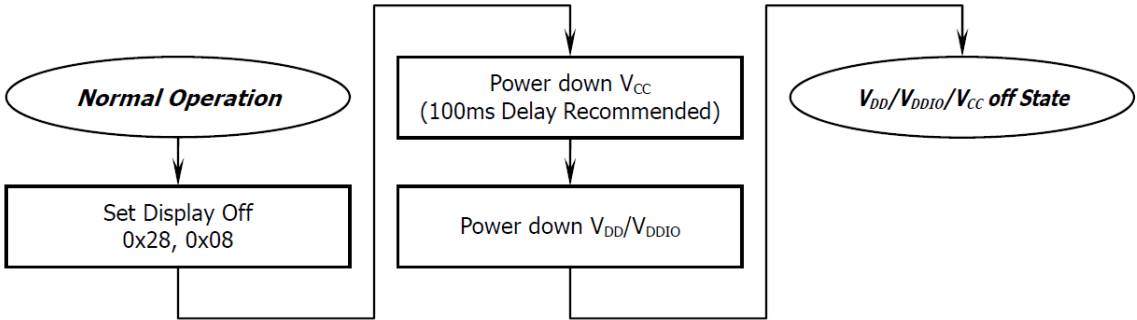

<Entering Sleep Mode>

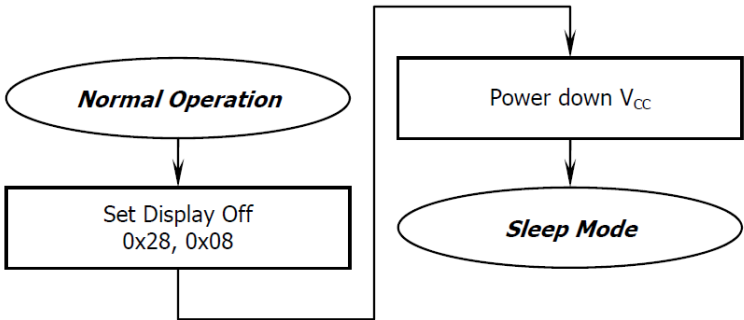

<Exiting Sleep Mode>

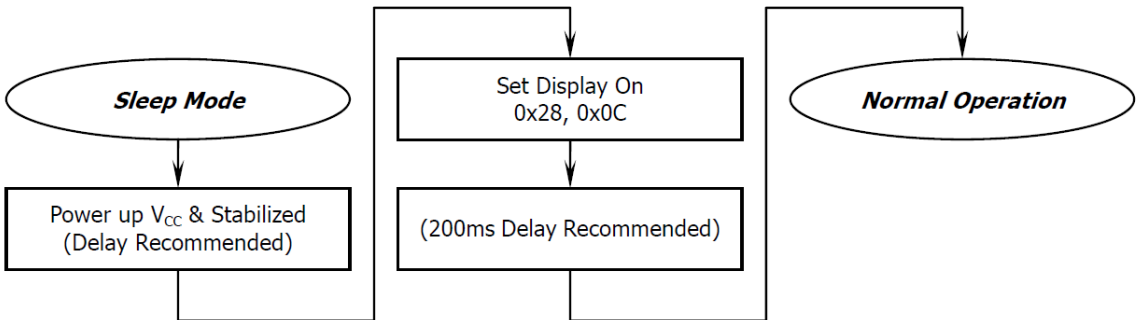

Product No.	DD-2C20BE-1A	REV. A

Page	23 / 42
------	---------

5.4.2 5V I/O Application

<Power up Sequence>

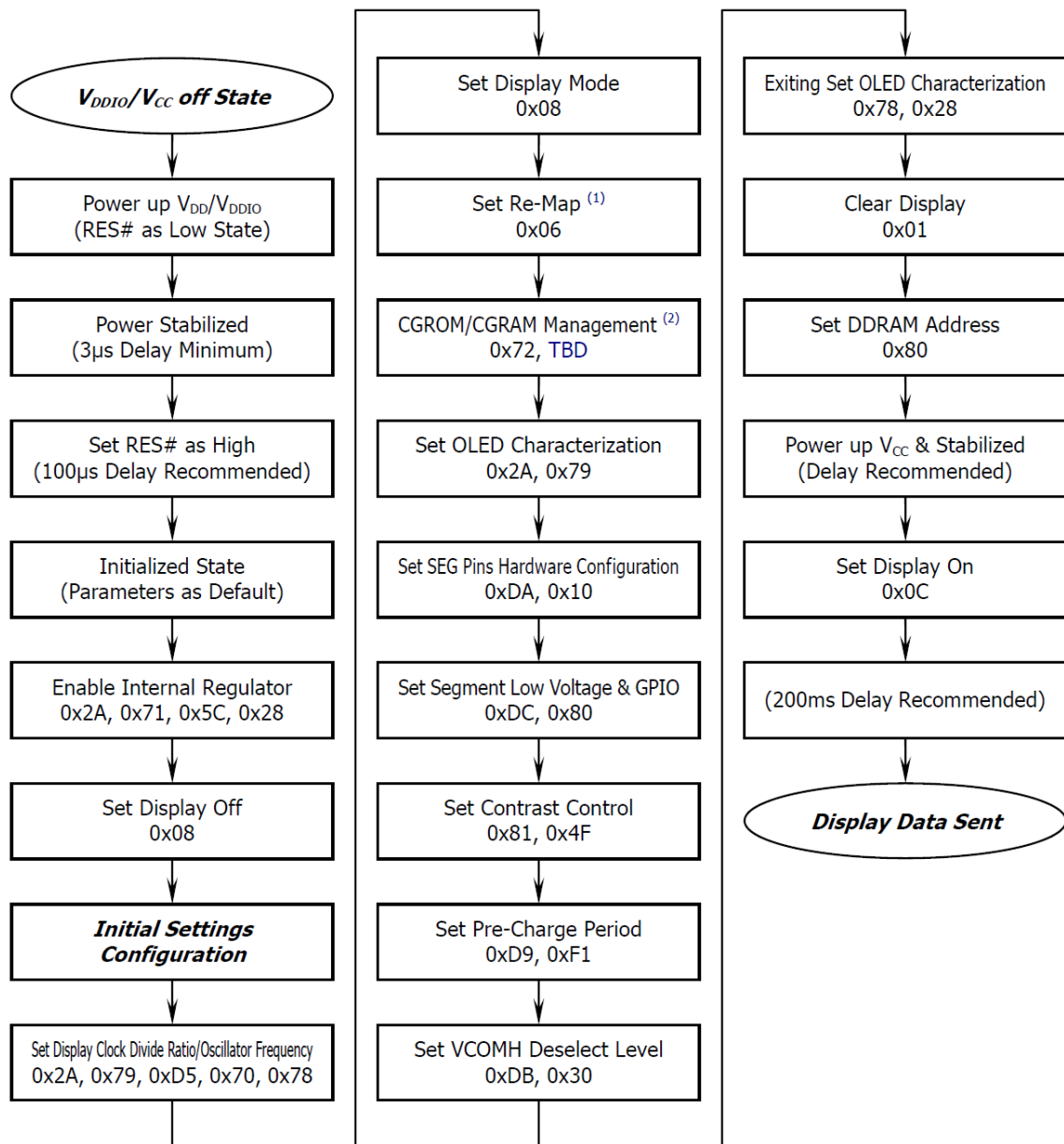

(1) This command could be programmable or defined by pin configuration.

(2) This command could be programmable or defined by pin configuration. The written value of the parameter should depend on the selection from section 5.5 and 5.6

If the noise is accidentally occurred at the displaying window during the operation, please reset the display in order to recover the display function.

Product No.	DD-2C20BE-1A	REV. A

Page	24 / 42
------	---------

<Power down Sequence>

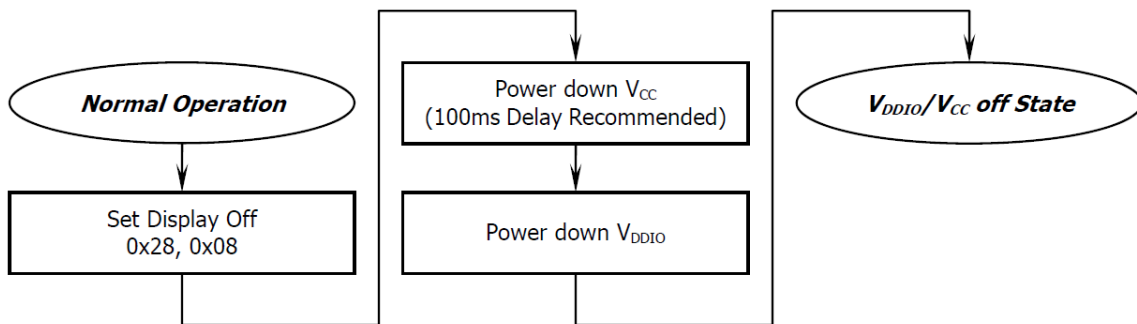

<Entering Sleep Mode>

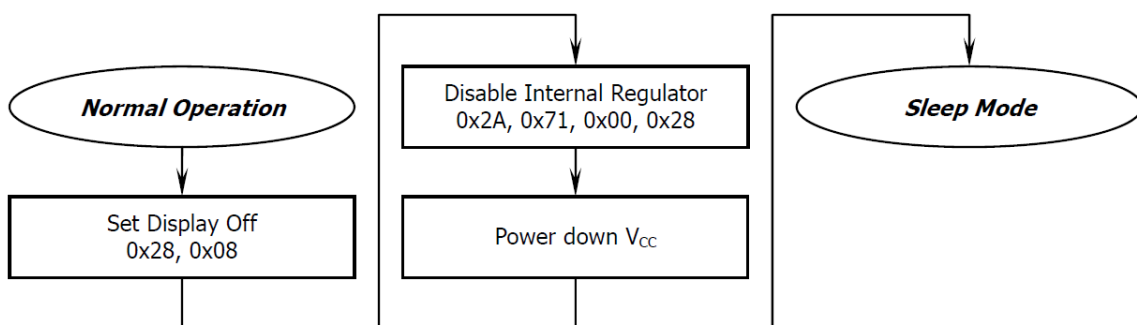

<Exiting Sleep Mode>

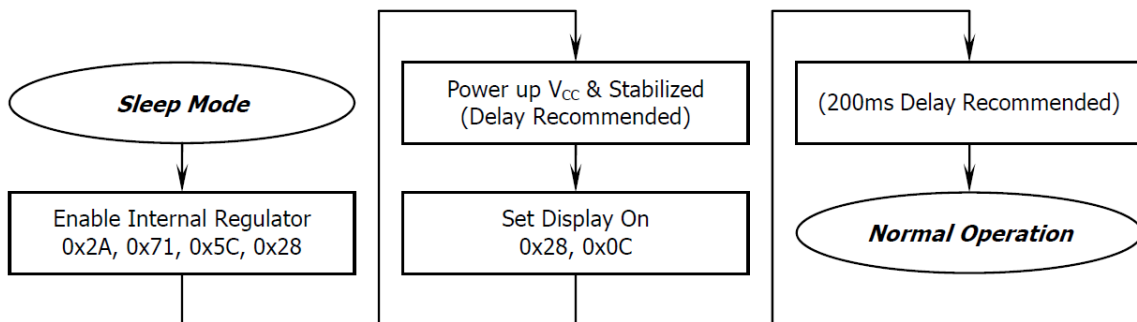

Product No.	DD-2C20BE-1A	REV. A

Page	25 / 42
------	---------

5.5 BUILD-IN CGROM (CHARACTER GENERATOR ROM)

5.5.1 ROMA

ROM A (ROM[1:0] = [0:0])

b7-4	0000	0001	0010	0011	0100	0101	0110	0111	1000	1001	1010	1011	1100	1101	1110	1111
0000																
0001																
0010																
0011																
0100																
0101																
0110																
0111																
1000																
1001																
1010																
1011																
1100																
1101																
1110																
1111																

Language: English, Irish, Spanish, Dutch (2), Danish, Norwegian, Swedish, Finnish, Czech (7), Slovene, Hungarian (2), Turkish (1)

The number in the parentheses is showing how many letters might be needed to build and define additionally at CGRAM. The darker background is showing the maximum addresses (00h~07h) those could be allocated by OPR[1:0] setting.

Product No.	DD-2C20BE-1A	REV. A

Page	26 / 42
------	---------

5.5.2 ROMB

ROM B (ROM[1:0] = [0:1])

b7-4 b3-0	0000	0001	0010	0011	0100	0101	0110	0111	1000	1001	1010	1011	1100	1101	1110	1111
0000																
0001																
0010																
0011																
0100																
0101																
0110																
0111																
1000																
1001																
1010																
1011																
1100																
1101																
1110																
1111																

Language: English, Irish, Portuguese, Spanish, French (1), Italian, German, Dutch (2), Icelandic, Danish, Norwegian, Swedish, Polish (8), Czech (8), Hungarian (2), Romanian (5), Turkish, Vietnamese (6), Russian (Small Letters)

The number in the parentheses is showing how many letters might be needed to build and define additionally at CGRAM. The darker background is showing the maximum addresses (00h~07h) those could be allocated by OPR[1:0] setting.

Product No.	DD-2C20BE-1A	REV. A

Page	27 / 42
------	---------

5.5.3 ROMC

ROM C (ROM[1:0] = [1:0])

b7-0	b7-4	0000	0001	0010	0011	0100	0101	0110	0111	1000	1001	1010	1011	1100	1101	1110	1111
0000		0	1	2	3	4	5	6	7	8	9	A	B	C	D	E	F
0001		G	H	I	J	K	L	M	N	O	P	Q	R	S	T	U	V
0010		W	X	Y	Z	0	1	2	3	4	5	6	7	8	9	A	B
0011		C	D	E	F	G	H	I	J	K	L	M	N	O	P	Q	R
0100		S	T	U	V	W	X	Y	Z	0	1	2	3	4	5	6	7
0101		8	9	A	B	C	D	E	F	G	H	I	J	K	L	M	N
0110		O	P	Q	R	S	T	U	V	W	X	Y	Z	0	1	2	3
0111		4	5	6	7	8	9	A	B	C	D	E	F	G	H	I	J
1000		K	L	M	N	O	P	Q	R	S	T	U	V	W	X	Y	Z
1001		0	1	2	3	4	5	6	7	8	9	A	B	C	D	E	F
1010		G	H	I	J	K	L	M	N	O	P	Q	R	S	T	U	V
1011		W	X	Y	Z	0	1	2	3	4	5	6	7	8	9	A	B
1100		C	D	E	F	G	H	I	J	K	L	M	N	O	P	Q	R
1101		S	T	U	V	W	X	Y	Z	0	1	2	3	4	5	6	7
1110		8	9	A	B	C	D	E	F	G	H	I	J	K	L	M	N
1111		O	P	Q	R	S	T	U	V	W	X	Y	Z	0	1	2	3

Language: English, Dutch (2), Japanese, Greek (Small Letters)

The number in the parentheses is showing how many letters might be needed to build and define additionally at CGRAM. The darker background is showing the maximum addresses (00h~07h) those could be allocated by OPR[1:0] setting.

Product No.	DD-2C20BE-1A	REV. A

Page	28 / 42
------	---------

5.6 SELF-DEFINED CGRAM (CHARACTER GENERATOR RAM)

8 Addresses Available for Self-Defined Characters (OPR[1:0] = [0:0])

b3-0 \ b7-4	0000	0001	0010	0011	0100	0101	0110	0111	1000	1001	1010	1011	1100	1101	1110	1111
0000																
0001																

8 Addresses Available for Self-Defined Characters (OPR[1:0] = [0:1])

b3-0 \ b7-4	0000	0001	0010	0011	0100	0101	0110	0111	1000	1001	1010	1011	1100	1101	1110	1111
0000																
0001																

6 Addresses Available for Self-Defined Characters (OPR[1:0] = [1:0])

b3-0 \ b7-4	0000	0001	0010	0011	0100	0101	0110	0111	1000	1001	1010	1011	1100	1101	1110	1111
0000																
0001																

0 Address Available for Self-Defined Characters (OPR[1:0] = [1:1])

b3-0 \ b7-4	0000	0001	0010	0011	0100	0101	0110	0111	1000	1001	1010	1011	1100	1101	1110	1111
0000																
0001																

Product No.	DD-2C20BE-1A	REV. A

Page	29 / 42
------	---------

6 PACKAGING AND LABELLING SPECIFICATION

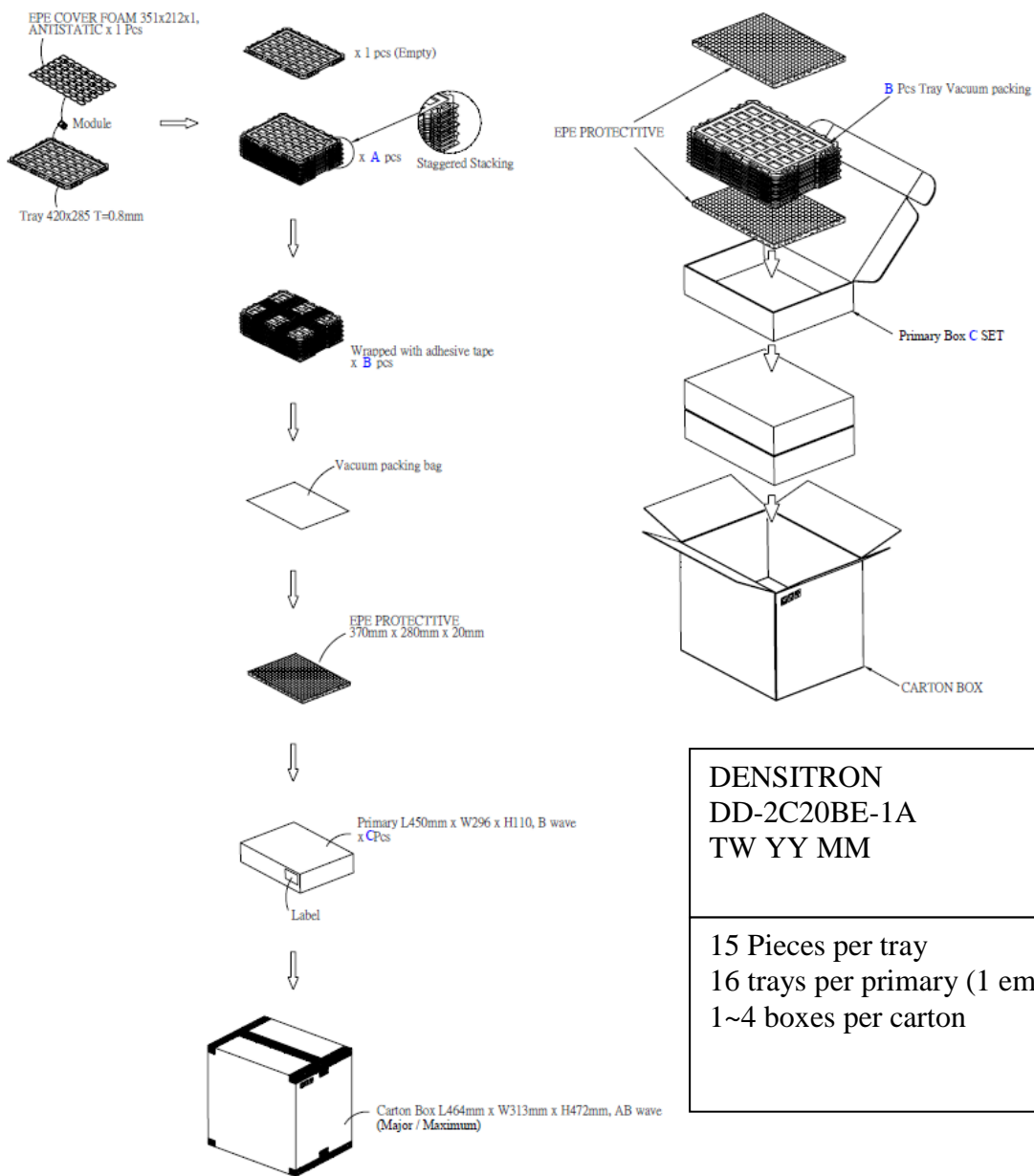

Product No.	DD-2C20BE-1A	REV. A

Page	30 / 42
------	---------

7 QUALITY ASSURANCE SPECIFICATION

7.1 CONFORMITY

The performance, function and reliability of the shipped products conform to the Product Specification.

7.2 DELIVERY ASSURANCE

7.2.1 DELIVERY INSPECTION STANDARDS

IPC-AA610, class 2 electronic assemblies standard

7.2.2 Zone definition

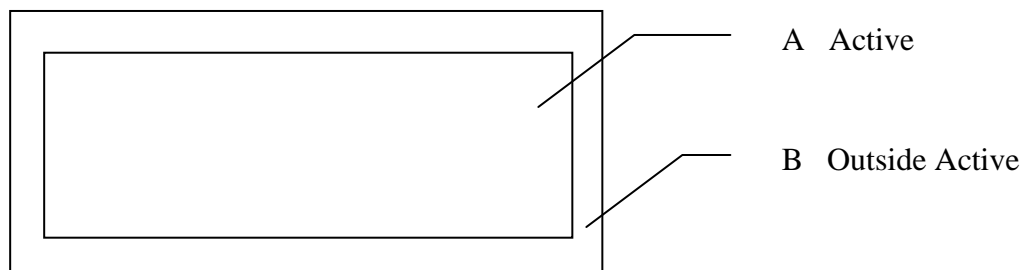

7.2.3 Visual inspection

Test and measurement to be conducted under following conditions:

Temperature:	$23 \pm 5^{\circ}\text{C}$
Humidity:	$55 \pm 15\% \text{RH}$
Fluorescent lamp:	30 W
Distance between the Panel & Eyes of the Inspector:	$\geq 30\text{cm}$
Distance between the Panel & the lamp:	$\geq 50\text{cm}$
Finger glove (or finger cover) must be worn by the inspector.	
Inspection table or jig must be anti-electrostatic	

Product No.	DD-2C20BE-1A	REV. A

Page	31 / 42
------	---------



7.2.4 Standard of appearance inspection

Partition	AQL	Definition
Major	0.65	Defects in Pattern Check (Display On)
Minor	1.0	Defects in Cosmetic Check (Display Off)

Check Item	Classification	Criteria
Panel General Chipping	Minor	<p>X > 6 mm (Along with Edge) Y > 1 mm (Perpendicular to edge)</p>

Product No.	DD-2C20BE-1A	REV. A

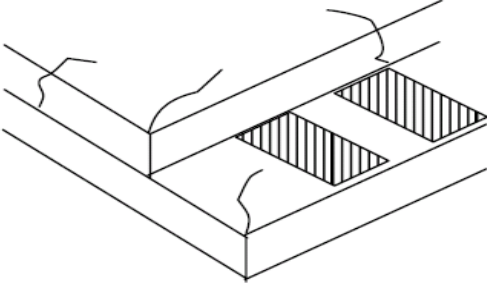
Page	32 / 42
------	---------

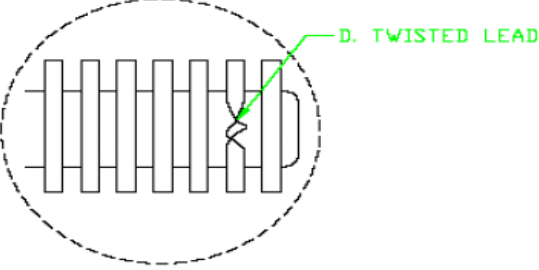
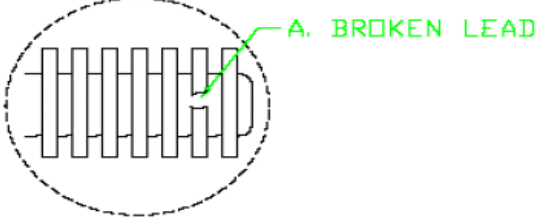
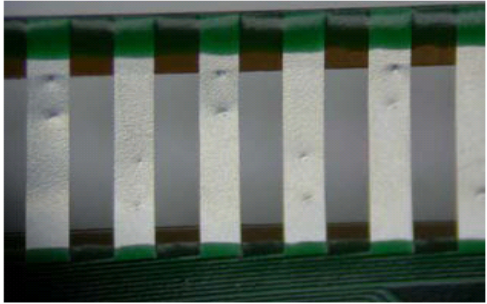
Check Item	Classification	Criteria
Panel Crack	Minor	<p>Any crack is not allowable.</p> 
Copper Exposed (Even Pin or Film)	Minor	<p>Not Allowable by Naked Eye Inspection</p>
Film or Trace Damage	Minor	
Terminal Lead Twist	Minor	<p>Not Allowable</p>  <p>D. TWISTED LEAD</p>
Terminal Lead Broken	Minor	<p>Not Allowable</p>  <p>A. BROKEN LEAD</p>
Terminal Lead Prober Mark	Acceptable	

Product No.	DD-2C20BE-1A	REV. A

Page	33 / 42
------	---------

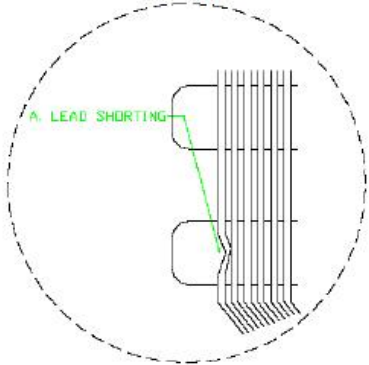
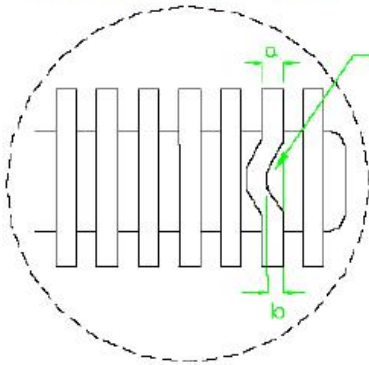
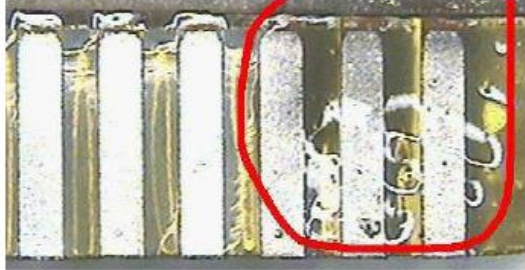
Check Item	Classification	Criteria
Terminal Lead Bent (Not Twist or Broken)	Minor	<p>NG if any bent lead cause lead shorting.</p> 
	Minor	<p>NG for horizontally bent lead more than 50% of its width.</p> 
Glue or Contamination on Pin (Couldn't Be Removed by Alcohol)	Minor	
Ink Marking on Back Side of panel (Exclude on Film)	Acceptable	Ignore for Any

Product No.	DD-2C20BE-1A	REV. A

Page	34 / 42
------	---------

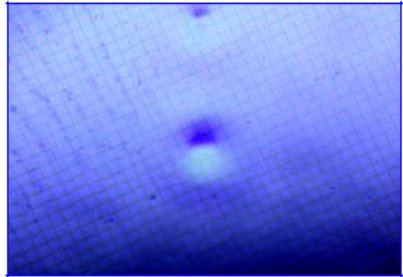
Check Item	Classification	Criteria
Any Dirt & Scratch on Polarizer's Protective Film	Acceptable	Ignore for not Affect the Polarizer
Scratches, Fiber, Line-Shape Defect (On Polarizer)	Minor	$W \leq 0.1$ Ignore $W > 0.1, L \leq 2$ $n \leq 1$ $L > 2$ $n = 0$
Dirt, Black Spot, Foreign Material, (On Polarizer)	Minor	$\Phi \leq 0.1$ Ignore $0.1 < \Phi \leq 0.25$ $n \leq 1$ $0.25 < \Phi$ $n = 0$
Dent, Bubbles, White spot (Any Transparent Spot on Polarizer)	Minor	$\Phi \leq 0.5$ → Ignore if no Influence on Display $0.5 < \Phi$ $n = 0$ 
Fingerprint, Flow Mark (On Polarizer)	Minor	Not Allowable

* Protective film should not be tear off when cosmetic check.

** Definition of W & L & Φ (Unit: mm): $\Phi = (a + b) / 2$

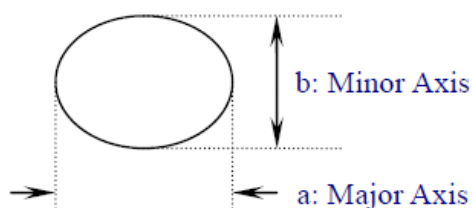
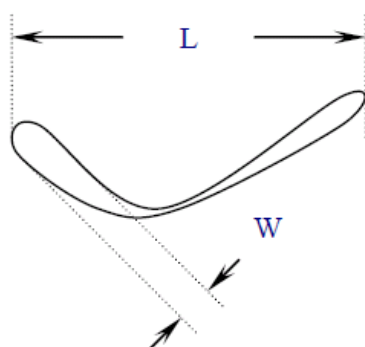

Product No.	DD-2C20BE-1A	REV. A

Page	35 / 42
------	---------

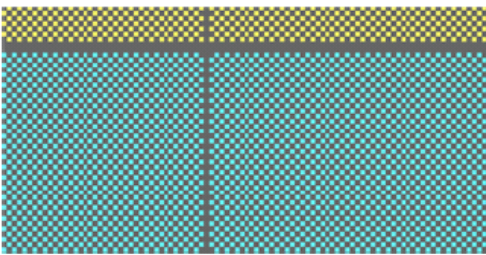
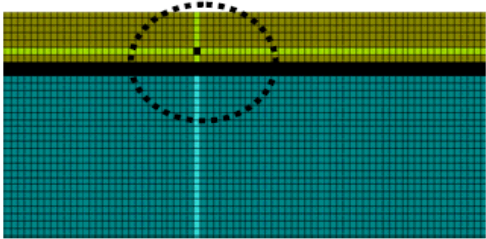
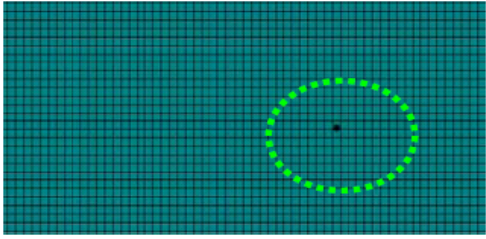
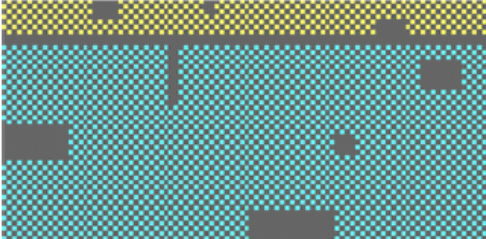
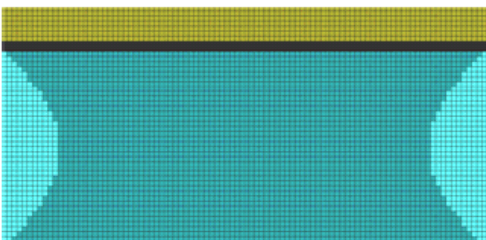
Check Item	Classification	Criteria
No Display	Major	
Flicker	Major	Not Allowable
Missing Line	Major	
Pixel Short	Major	
Darker Pixel	Major	
Wrong Display	Major	
Un-uniform	Major	

7.3 DEALING WITH CUSTOMER COMPLAINTS

7.3.1 Non-conforming analysis

Purchaser should supply Densitron with detailed data of non-conforming sample.

After accepting it, Densitron should complete the analysis in two weeks from receiving the sample.

If the analysis cannot be completed on time, Densitron must inform the purchaser.

7.3.2 Handling of non-conforming displays

If any non-conforming displays are found during customer acceptance inspection which Densitron is clearly responsible for, return them to Densitron.

Both Densitron and customer should analyse the reason and discuss the handling of non-conforming displays when the reason is not clear.

Equally, both sides should discuss and come to agreement for issues pertaining to modification of Densitron quality assurance standard.

Product No.	DD-2C20BE-1A	REV. A

Page	37 / 42
------	---------

8 RELIABILITY SPECIFICATION

8.1 RELIABILITY TESTS

Test Item	Test Condition	Criteria
High Temperature Operation	85°C, 240 hours	The operational functions work
Low Temperature Operation	-40°C, 240 hours	The operational function works
High Temperature Storage	90°C, 240 hours	The operational function works
Low Temperature Storage	-40°C, 240 hours	The operational function works
High Temperature & High Humidity Storage	60°C, 90%RH, 240 hours	The operational function works
Thermal Shock	-40°C ⇔ 85°C, 100 cycles. 60 Mins dwell	The operational function works

- The samples used for above tests do not include polarizer.
- No moisture condensation is observed during tests.

8.1.1 FAILURE CHECK STANDARD

After the completion of the described reliability test, the samples were left at room temperature for 2 hrs prior to conducting the failure test at 23±5 °C; 55±15% RH.

8.2 LIFE TIME

Item	Description												
1	Function, performance, appearance, etc. shall be free from remarkable deterioration more than 15000 hours under 80 cd/m ² brightness and 50% Checkerboard, humidity (50% RH), and in area not exposed to direct sunlight. Software configuration follows Section 5.4 Initialization. <table border="1" data-bbox="300 1579 1412 1691"> <thead> <tr> <th>Parameter</th> <th>Min</th> <th>Max</th> <th>Conditions</th> </tr> </thead> <tbody> <tr> <td>Life Time (80 cd/m²)</td> <td>15,000</td> <td>-</td> <td>V_{cc}=9V, T_a=25°C, 50% Checkerboard.</td> </tr> <tr> <td>Life Time (60 cd/m²)</td> <td>25,000</td> <td>-</td> <td></td> </tr> </tbody> </table>	Parameter	Min	Max	Conditions	Life Time (80 cd/m ²)	15,000	-	V _{cc} =9V, T _a =25°C, 50% Checkerboard.	Life Time (60 cd/m ²)	25,000	-	
Parameter	Min	Max	Conditions										
Life Time (80 cd/m ²)	15,000	-	V _{cc} =9V, T _a =25°C, 50% Checkerboard.										
Life Time (60 cd/m ²)	25,000	-											
2	End of lifetime is specified as 50% of initial brightness. The average operating lifetime at room temperature is estimated by the accelerated operation at high temperature conditions.												

Product No.	DD-2C20BE-1A	REV. A
-------------	--------------	--------

Page	38 / 42
------	---------

9 HANDLING PRECAUTIONS

9.1 HANDLING PRECAUTIONS

- 1) Since the display panel is being made of glass, do not apply mechanical impacts such as dropping from a high position.
- 2) If the display panel is broken by some accident and the internal organic substance leaks out, be careful not to inhale nor lick the organic substance.
- 3) If pressure is applied to the display surface or its neighborhood of the OEL display module, the cell structure may be damaged and be careful not to apply pressure to these sections.
- 4) The polarizer covering the surface of the OEL display module is soft and easily scratched. Please be careful when handling the OEL display module.
- 5) When the surface of the polarizer of the OEL display module has soil, clean the surface. It takes advantage of by using following adhesion tape.
 - * Scotch Mending Tape No. 810 or an equivalent
 Never try to breathe upon the soiled surface nor wipe the surface using cloth containing solvent such as ethyl alcohol, since the surface of the polarizer will become cloudy.
 Also, pay attention that the following liquid and solvent may spoil the polarizer:
 - * Water
 - * Ketone
 - * Aromatic Solvents
- 6) Hold OEL display module very carefully when placing OEL display module into the system housing. Do not apply excessive stress or pressure to OEL display module. And, do not over bend the film with electrode pattern layouts. These stresses will influence the display performance. Also, secure sufficient rigidity for the outer cases.

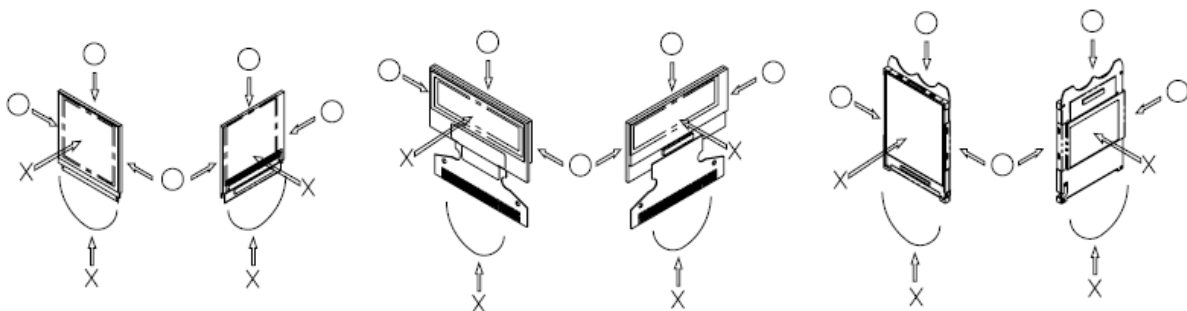

- 7) Do not apply stress to the LSI chips and the surrounding molded sections.
- 8) Do not disassemble nor modify the OEL display module.
- 9) Do not apply input signals while the logic power is off.
- 10) Pay sufficient attention to the working environments when handing OEL display modules to prevent occurrence of element breakage accidents by static electricity.
 - * Be sure to make human body grounding when handling OEL display modules.
 - * Be sure to ground tools to use or assembly such as soldering irons.
 - * To suppress generation of static electricity, avoid carrying out assembly work under dry environments.

Product No.	DD-2C20BE-1A	REV. A

Page	39 / 42
------	---------

* Protective film is being applied to the surface of the display panel of the OEL display module. Be careful since static electricity may be generated when exfoliating the protective film.

- 11) Protection film is being applied to the surface of the display panel and removes the protection film before assembling it. At this time, if the OEL display module has been stored for a long period of time, residue adhesive material of the protection film may remain on the surface of the display panel after removed of the film. In such case, remove the residue material by the method introduced in the above Section 5).
- 12) If electric current is applied when the OEL display module is being dewed or when it is placed under high humidity environments, the electrodes may be corroded and be careful to avoid the above.

9.2 STORAGE PRECAUTIONS

- 1) When storing OEL display modules, put them in static electricity preventive bags avoiding exposure to direct sun light nor to lights of fluorescent lamps, etc. and, also, avoiding high temperature and high humidity environments or low temperature (less than 0°C) environments. (We recommend you to store these modules in the packaged state when they were shipped from Densitron Technologies Plc.) At that time, be careful not to let water drops adhere to the packages or bags nor let dewing occur with them.
- 2) If electric current is applied when water drops are adhering to the surface of the OEL display module, when the OEL display module is being dewed or when it is placed under high humidity environments, the electrodes may be corroded and be careful about the above.

9.3 DESIGNING PRECAUTIONS

- 1) The absolute maximum ratings are the ratings which cannot be exceeded for OEL display module, and if these values are exceeded, panel damage may be happen.
- 2) To prevent occurrence of malfunctioning by noise, pay attention to satisfy the VIL and VIH specifications and, at the same time, to make the signal line cable as short as possible.
- 3) We recommend you to install excess current preventive unit (fuses, etc.) to the power circuit (VDD). (Recommend value: 0.5A)
- 4) Pay sufficient attention to avoid occurrence of mutual noise interference with the neighboring devices.
- 5) As for EMI, take necessary measures on the equipment side basically.
- 6) When fastening the OEL display module, fasten the external plastic housing section.
- 7) If power supply to the OEL display module is forcibly shut down by such errors as taking out the main battery while the OEL display panel is in operation, we cannot guarantee the quality of this OEL display module.
- 8) The electric potential to be connected to the rear face of the IC chip should be as follows: US2066
* Connection (contact) to any other potential than the above may lead to rupture of the IC.

Product No.	DD-2C20BE-1A	REV. A

Page	40 / 42
------	---------

9.4 OTHER PRECAUTIONS

- 1) When an OEL display module is operated for a long of time with fixed pattern may remain as an after image or slight contrast deviation may occur. Nonetheless, if the operation is interrupted and left unused for a while, normal state can be restored. Also, there will be no problem in the reliability of the module.
- 2) To protect OEL display modules from performance drops by static electricity rapture, etc., do not touch the following sections whenever possible while handling the OEL display modules.
 - * Pins and electrodes
 - * Pattern layouts such as the FPC
- 3) With this OEL display module, the OEL driver is being exposed. Generally speaking, semiconductor elements change their characteristics when light is radiated according to the principle of the solar battery. Consequently, if this OEL driver is exposed to light, malfunctioning may occur.
 - * Design the product and installation method so that the OEL driver may be shielded from light in actual usage.
 - * Design the product and installation method so that the OEL driver may be shielded from light during the inspection processes.
- 4) Although this OEL display module stores the operation state data by the commands and the indication data, when excessive external noise, etc. enters into the module, the internal status may be changed. It therefore is necessary to take appropriate measures to suppress noise generation or to protect from influences of noise on the system design.
- 5) We recommend you to construct its software to make periodical refreshment of the operation statuses (re-setting of the commands and re-transference of the display data) to cope with catastrophic noise.

Product No.	DD-2C20BE-1A	REV. A

Page	41 / 42
------	---------

10 SUPPORTED ACCESSORIES

10.1 DUO KIT

Densitron has developed an easy to use yet powerful development and demonstration tool for driving its range of Passive Matrix OLED displays from the USB port of a PC.

DUO (Densitron USB OLED) kit is hot pluggable and does not require extra cables or power supply to run, allowing users to be up and running in minutes.

The kit consists of an OLED display with transition Board, USB controller card, mini USB cable and a CD with software application and drivers.



Part number: PDK-N-2C20BE-1A

10.1 TRANSITION BOARD CARD

A Transition board card is like a daughterboard which is meant to be a circuit board for connections between the baseboards (DUO).

It has connector pins for interfacing between the display and the baseboards.

It also includes the OLED display.

Part number: PDT- N-2C20BE-1A

10.2 CONNECTOR BOARD CARD

A Connector board card is also a daughterboard which is a circuit board for connection between a microprocessor or microcontroller (customer's system).

Part number: EVK-CONNECT-029

10.3 CONNECTOR

Type: hot bar soldering process

No. of connections: 33

Pitch: 0.70mm

10.4 APPLICATION NOTES AND EXAMPLE CODES

On request to Densitron

Product No.	DD-2C20BE-1A	REV. A

Page	42 / 42
------	---------