

## MINISTART Softstarter With Softstop GC 9012

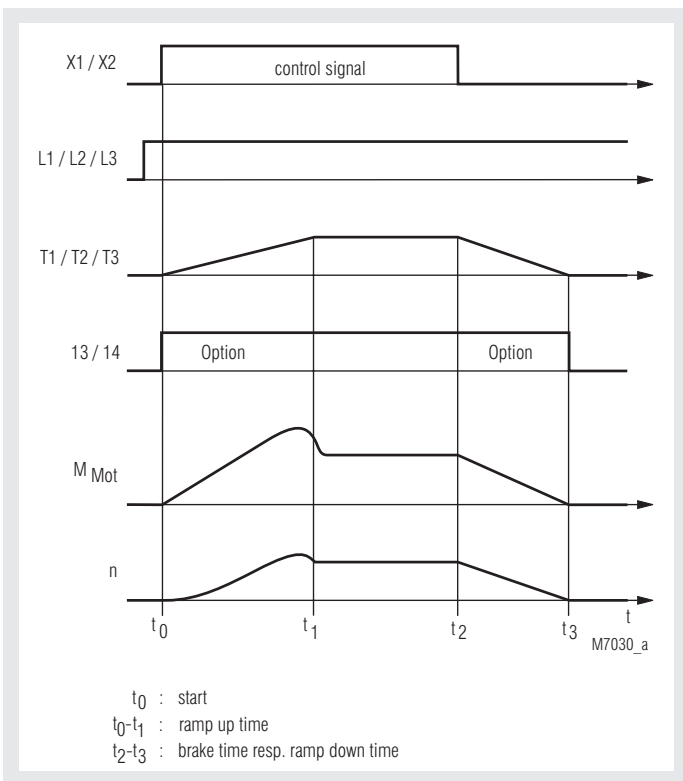

- Increases life of squirrel cage motors and mechanical drives
- For motors up to 11 kW, 3-phase
- Easily fitted to existing installations
- 3-phase control softstart and softstop DC injection braking option
- DIN-rail mounting
- Available with braking option (only up to 5.5 kW)
- Integrated fault monitoring functions
- Metal enclosure IP 30
- Start current limited to 2 to 3 times rated motor current
- Semiconductors bridged after softstart
- Adjustable ramp time, starting torque and deceleration time
- LED indication
- Width 166 mm

### Function Diagram



### Approvals and Marking



### Applications

- Motors with gear, belt or chain drive
- Fans, pumps, conveyor systems, compressors
- Woodworking machines, centrifuges
- Start current limiting on 3-phase motors
- Reduces on off current on transformers and P.S.U.'s
- DC injection braking on high inertia systems

### Function

Softstarters are electronic devices designed to enable 1-phase or 3-phase induction motors to start smoothly. The GC 9012 slowly ramps up the current on three phases, therefore allowing the motor torque to build up slowly. This reduces the mechanical stress on the machine and prevents damage to conveyed material.

When the motor is up to full speed the semiconductors in GC 9012 are bridged to prevent internal power losses and heat build up. In addition GC 9012 allows a softstop function prolonging the stop time of the motor, preventing high counter torques from abruptly stopping the motor. A DC injection braking option is also available in place of the softstop function.

### Indication

LED green	"Supply"	ON	= power connected
LED yellow right	"Start"	ON	= soft start active
LED yellow left	"Bypass"	ON	= power semiconductors bridged
LED red	"Fault"	ON	= fault

### Block Diagram

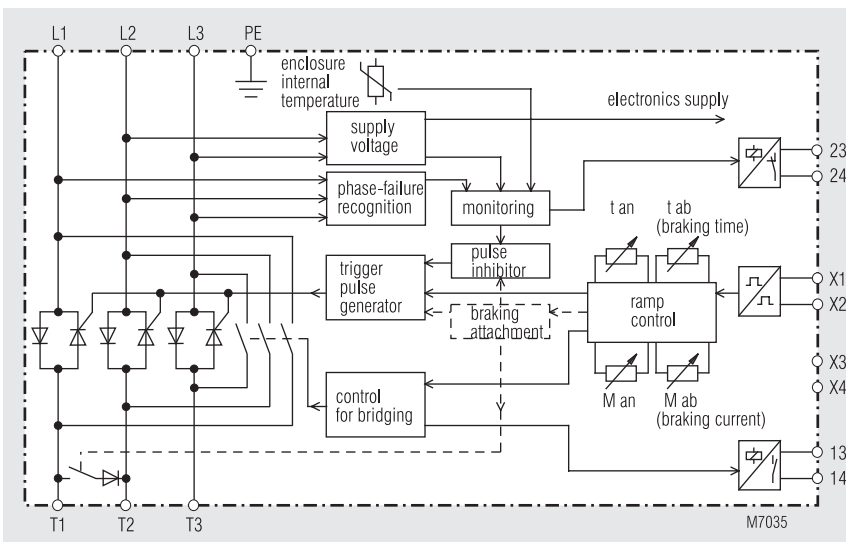

## Principle of Operation

For direct on line or start delta applications, terminals L1, L2, L3 are connected to the mains contactor, with the motor connected to terminals T1, T2, T3 and a 24 V DC control signal is connected to terminals X3-X2.

When power is connected to terminals L1, L2, L3 and 24 V DC is present at terminals X3-X2, the softstart will commence. Potentiometer "t<sub>an</sub>" (1-2 sec.) adjusts the ramp time (time motor takes to get to full speed) and potentiometer "M<sub>an</sub>" adjusts the start voltage (0 - 80 % nomV). When the softstart is complete the internal semi-conductors are automatically bridged.

When 24 V DC is removed from terminals X3-X2, the softstop function will commence for the deceleration time period set on potentiometer "t<sub>ab</sub>" (0 - 20 sec.) and deceleration voltage level set on potentiometer "M<sub>ab</sub>" (20 - 80 % nomV).

If the motor brake function is specified, i. e. /001 option. When 24 V DC is removed from terminals X3-X2 the motor brake function will commence for braking time period set on potentiometer t<sub>br</sub> (0.75 - 15 sec). The braking current level is set on potentiometer I<sub>br</sub>.

## Notes

Motor load must always be connected as continuous operation of the softstart with no load may cause overheating of the motor and softstart.

It is recommended that the softstart is protected by superfast semi-conductor fuses rated as per the current rating of the softstart or motor. However, standard line and motor protection is acceptable, but for high starting frequencies motor winding temperature monitoring is recommended.

## Technical Data

<b>Nominal voltage:</b>	3 AC 400 V ± 15 %
<b>Nominal frequency:</b>	50/60 Hz
<b>Nominal motor power P<sub>N</sub></b> at 400 V:	1.5 kW 3 kW 5.5 kW 7.5 kW 11 kW
<b>Min. motor power:</b>	approx. 10 % of rated motor power
<b>Start torque:</b>	0 ... 80 % adjustable
<b>Ramp time:</b>	1 ... 20 s
<b>Deceleration torque:</b>	20 ... 80 % adjustable
<b>Deceleration time</b>	
GC 9012:	0 ... 20 s adjustable
GC 9012/001:	0.75 ... 15 s adjustable
<b>Recovery time:</b>	200 ms
<b>Switching frequency</b>	
GC 9012:	120/h 120/h 120/h 60/h 20/h
GC 9012/001:	90/h 90/h 90/h - -
<b>Power consumption:</b>	3 W
<b>Temperature range:</b>	- 10 ... + 45 °C not bedewing
<b>Storage temperature:</b>	- 25 ... + 75 °C
<b>External fuse (optional)</b>	
<b>superfast:</b>	16 A 25 A 35 A 80 A 100 A
<b>Degree of protection:</b>	IP 20
<b>Wire connection:</b>	up to 2.5 mm <sup>2</sup> stranded ferruled
<b>Mounting:</b>	DIN-rail mounting
<b>Weight</b>	
GC 9012:	1200 g 1200 g 1350 g 1500 g 1500 g
GC 9012/001:	1250 g 1250 g 1400 g - -

## Dimensions

**Width x height x depth:** 166 x 106 x 117 mm

## Standard Type

GC 9012	3 AC 400 V	50/60 Hz	1.5 kW	
Article number:			0045210	stock item
• Nominal voltage:	3 AC 400 V			
• for motors up to 1.5 kW				
• Width:	166 mm			

## Variants

GC 9012/001:	To achieve shorter motor braking times, GC 9012, can be equipped with DC-braking attachment instead of the soft stop function
GC 9012/010:	The contact 13-14 is closed at the beginning of the soft start until the end of the soft stop
GC 9012/011:	A unit with the DC-braking option, contact 13-14 is closed when the power semiconductors are bridged.

## Variants

### Ordering example for variants

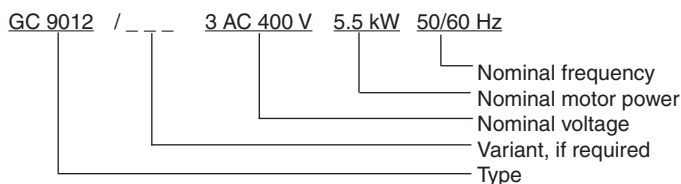

## Installation

The device must be mounted on a vertical mounting area with the connections in a vertical plane, i.e. top to bottom.

Ensure that no external heat source is placed below the unit and a 40 mm air gap is maintained above and below. Other devices may be directly mounted either side of the unit.

**Attention:** On the terminal strip there are 12 terminals starting from the left, the first 4 terminals are unused. The legend on the housing and PCB are:



X1	X2	X3	X4	13	14	23	24
5	6	7	8	9	10	11	12

## Control Input

### 1. Volt free contact operation

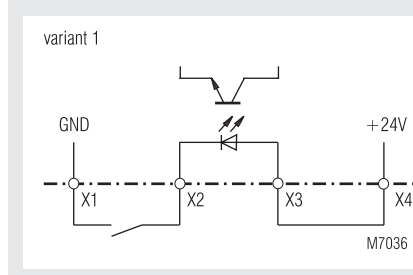

Fit link between terminals X3-X4 when terminals X1-X2 are bridged by an external volt-free contact, the softstart function will commence.

When the contact is opened the softstop or braking function will commence.

### 2. External DC24V operation

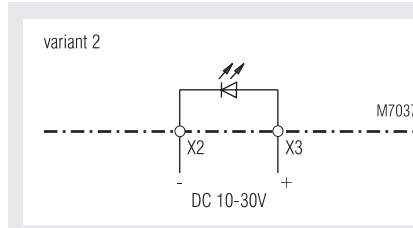

Terminals X1 and X4 must remain unconnected. When DC24V is applied to terminals X2(-) - X3(+) the softstart function will commence.

When this voltage is removed the softstop or braking function will commence.

### 3. Mains contactor operation

If only soft starting is required terminals X1-X2 and X3-X4 should be bridged and the unit will operate when voltage is applied to L1, L2, L3.

## Monitoring Output

The GC 9012 has two voltfree output contacts which indicate the following:

**Terminals 13-14:**

With softstart and softstop versions, this contact closes when the power semiconductors are bridged. With units that have the braking option, this contact will close when the softstart function commences and open when the braking function is complete.

**Terminals 23-24:**

When the unit is connected to the supply voltage this contact will close. If the supply voltage fails or an internal fault is detected, this contact will open.

## Set-up Procedure

Set potentiometer "M<sub>an</sub>" to minimum (fully anti-clockwise).  
 Set potentiometer "M<sub>ab</sub>" to maximum (fully clockwise).  
 Set potentiometer "t<sub>br</sub>" to minimum (fully anti-clockwise), "brake option"  
 Set potentiometer "t<sub>ab</sub>" to maximum (fully clockwise).  
 Set potentiometer "t<sub>an</sub>" to maximum position (fully clockwise).  
 Set potentiometer "t<sub>br</sub>" to maximum (fully clockwise), "brake option"  
 Start the motor and turn potentiometer "M<sub>an</sub>" up until the motor starts to turn without excessive humming.  
 stop the motor and restart.  
 Adjust potentiometer "t<sub>an</sub>" to give the desired ramp time.  
 Stop and restart the motor (see also motor brake option).  
 Adjust potentiometer "M<sub>ab</sub>" until the motor starts to visibly slow down at the initiation of the softstop cycle.  
 Restart and Stop the motor.  
 Adjust potentiometer "t<sub>ab</sub>" to give the desired deceleration time.  
 Restart and Stop the motor, readjusting the potentiometers until the desired starting/stopping characteristics are achieved.

### Softstart DC brake option:

Initiate a stop cycle on the unit.  
 Adjust potentiometer "I<sub>br</sub>" until desired stop current is flowing, NB current should be monitored in line T1 with a true Rms ammeter or moving iron ammeter (max. 2 times rated motor current).  
 Restart and stop the motor.  
 Adjust potentiometer "t<sub>br</sub>" to approximatley.  
 1 to 2 sec longer than the stopping time of the motor.  
 Start and stop the motor until the desired stopping characteristics are achieved.  
 If during the braking cycle a start signal is recieved, the braking cycle will be completed before restarting.

## Set-up Procedure

- **Attention:** If the ramp-up time is adjusted to short, the internal bridging contact closes before the motor is on full speed. This may damage the bridging contactor or bridging relay.



## Fault Indication

GC 9012 incorporates integrated monitoring and indication of the following fault conditions:

- overtemperature
- phase failure
- internal power supply failure

The red fault LED will illuminate and contact 23-24 will open. The fault condition may be reset by momentarily removing the voltage at terminals L1, L2, L3.

## Safety Instructions

- Never clear a fault when the device is switched on
- **Attention:** This device can be started by potential-free contact, while connected directly to the mains without contactor (see application example). Please note, that even if the motor is at rest, it is not physically separated from the mains. Because of this the motor **must** be disconnected from the mains via the corresponding manual motor starter.
- **Attention:** The terminals X1 and X4 are not galvanically separated from the mains. The control contact should be potential-free and must have a test voltage rating of 2.5 kV.
- The user must ensure that the device and the necessary components are mounted and connected according to the locally applicable regulations and technical standards.
- Adjustments may only be carried out by qualified specialist staff and the applicable safety rules must be observed.



## Application Example

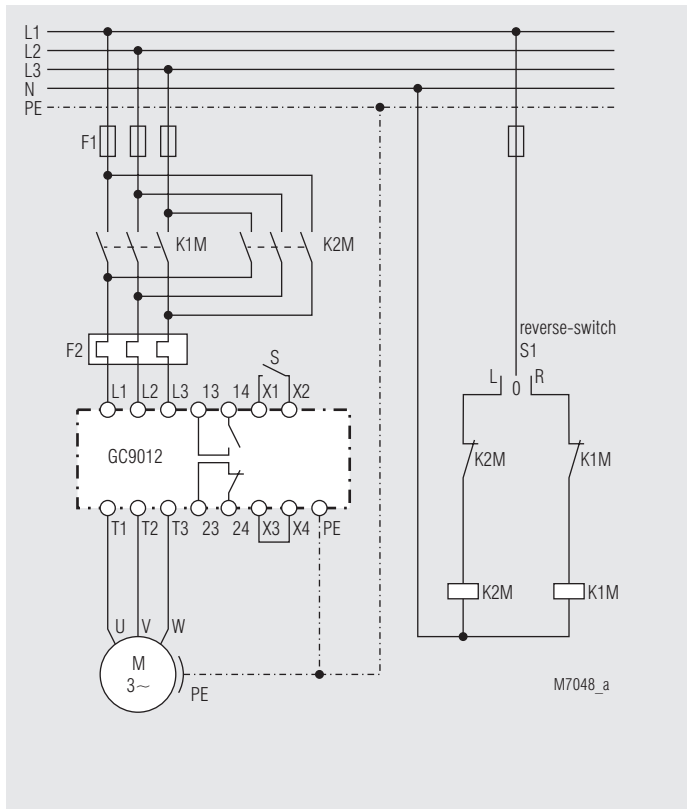

GC 9012 with volt free contact control at X1 - X2

Softstart and softstop or brake-function and reversing

Attention: Either softstop or braking is available (dependent on model)

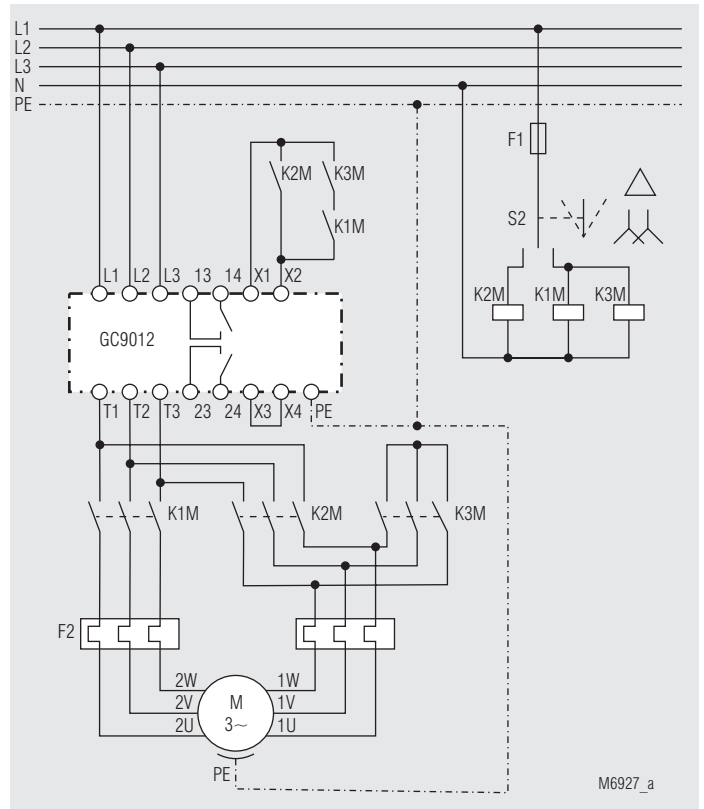

Softstart for change-pole motors (Dahlander)

Attention: In this case potentiometer "t<sub>ab</sub>" to left end position i.e. softstop is not available

