

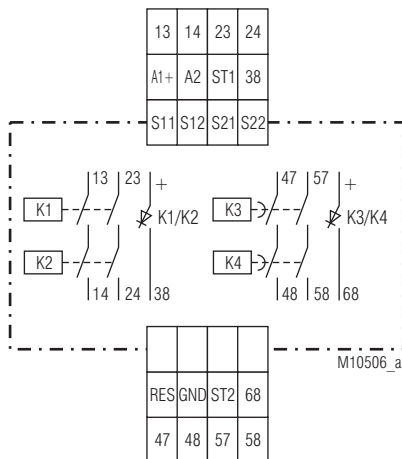

### Product Description

The multifunction safety timer UG 6960 provides protection of men and machines by enabling and disabling a safety circuit. This is done by the adjusted time delay function. Simply select 1 out of 5 delay functions with a rotary switch – ready. The adjusted time is safe over the complete setting range. The UG 6960 is available for different safety functions. It has safe delayed and instantaneous contacts.

### Circuit Diagram



### Connection Terminals

Terminal designation	Signal designation
A1 +	DC 24 V
A2	0 V
13, 14, 23, 24	Forcibly guided NO contacts for release circuit
47, 48, 57, 58	Forcibly guided NO contacts for delayed contacts
38, 68	Semiconductor monitoring output
GND	Reference potential for Semiconductor monitoring output
S11, S21	Control output
S12, S22, ST1, ST2, RES	Control input

### Your Advantage

- **Various delay functions adjustable at device:**
  - Release delay
  - Release delay retriggerable
  - On delay
  - Fleeting on make / break
  - Delay function settable via potentiometer
- **Various safety functions defined:**
  - E-Stop
  - Safety gate
  - Two-hand control
  - Safety mat / Safety edge
  - Exclusive or contacts
  - Light curtain
- Manual or auto start
- Instantaneous contact and safety delayed contacts

### Features

- **According to**
  - **Performance Level (PL) e and category 4 to EN ISO 13849-1: 2008**
  - **SIL Claimed Level (SIL CL) 3 to IEC/EN 62061**
  - **Safety Integrity Level (SIL) 3 to IEC/EN 61508 and IEC/EN 61511**
- Acc. to EN 50156-1 for furnaces
- Line fault detection on On-button:
- Manual restart or automatic restart
- With or without cross fault monitoring
- 2-channel
- Forcibly guided output contacts
- Output: 2 NO instantaneous contact and 2 NO contacts delayed
- 1 semiconductor output for instantaneous contacts  
1 semiconductor output for delayed contacts
- LED indicator for operation, safety function, time delay and failure
- As option with pluggable terminal blocks for easy exchange of devices
  - with screw terminals
  - or with cage clamp terminals
- Width: 22.5 mm

### Approvals and Markings



### Application

Protect people and machines in applications with e-stop buttons, safety gates, light curtains with selftesting (Type 4) acc. to IEC/EN 61 496-1, 2-hand controls for presses as well as other production machinery with dangerous closing action (Type III C to EN 574) and for safety mats, safety edges and tape switches with a max. switching current of 15 mA.

### Indicators

- green LED ON: on, when supply connected
- red LED ERR: on, at internal error  
flashes at external error
- green LED K1/K2: on, when relay K1 and K2 energized (instantaneous contact)  
flashes at external errors
- green LED K3/K4: on, when relay K3 and K4 energized (delayed contacts)  
flashes during time delay

## Function Diagram

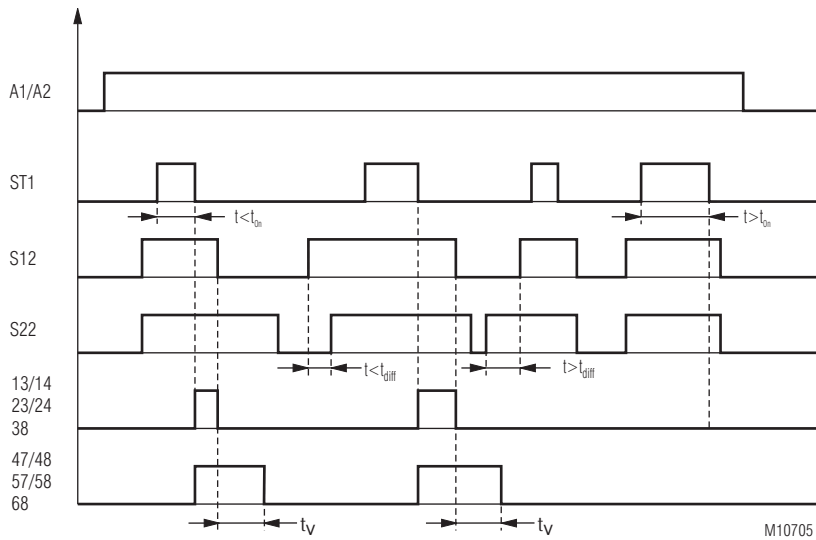

M10705

$t_{diff}$ : max. time delay for simultaneity demand  
dependent on selected safety function  
E-Stop, safety gate, safety mat  $t_{diff}$ : max. 3s  
Light curtains  $t_{diff}$ : max. 1s  
Two-hand control  $t_{diff}$ : max. 0,5s  
other times on request

$t_{ein}$ : max. actuation time of start button  
Standard  $t_{ein}$ : max. 3s  
other times on request

$t_v$ : Time delay  
Example: release delay

## Block Diagram

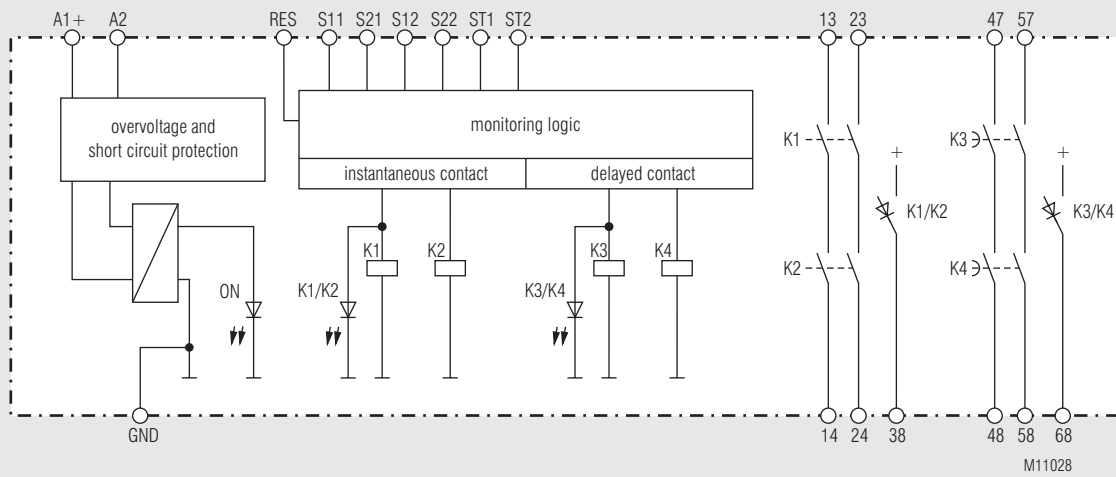

M11028

**Operating mode**

Manual or auto start is chosen by wiring. On manual start S21 has to be connected to ST1! via an NO push button. For auto start S21 is connected to ST2. If both inputs are connected to S21 the unit goes into safe failure mode. A restart or new start of the device has to be made. Only an automatic start at safety function two-hand control/3\_\_ is possible.

**Line fault detection e.g. monitoring of ON-button**

If the On-button pressed more than 3 s the adequate output contacts of the safety function can't be switch. The output contacts can be energized when the On-button pressed again ( $0.1 \text{ s} < t_{\text{ON}} < 3 \text{ s}$ ).

A line fault is detected if the On-button more than 10 s is actuated. The output contacts of the adequate safety function can only be energized with a reset or re-start with on an off switching of power supply.

**ATTENTION - AUTOMATIC START!**



According to IEC/EN 60 204-1 part 9.2.5.4.2 and 10.8.3 it is not allowed to restart automatically after emergency stop. Therefore the machine control has to disable the automatic start after emergency stop.

**Reset and external failures:**

The reset input is used to reset external failures (application failures or removable external failures as e.g. a line fault on reset button). If the reset signal is connected to the input for more than 3 sec the unit makes a reset. A new reset is only possible when the reset signal had been switched off temporarily.

If an external failure occurs because both input channels of a safety function did not switch on or off within the simultaneous time, a reset is only possible if both channels are switched to off state after removing failure cause.

**Setting delay mode**

On the variant /\_0\_ the delay mode can be set via rotary switch  $t_{\text{Fkt}}$ .

Possible functions:

$t_{\text{Fkt}}$	Function
1	Release delay
2	Release delay retriggerable
3	On delay
4	Fleeting on make
5	Fleeting on break

**Adjusting the time delay**

With rotary switch  $t_{\text{max}}$  the time range for the delayed contacts is selected. With rotary switch t the time is adjusted within the selected range in 10 % steps.

Example: required time = 0.8 s

**1. Example:**

$$t_{\text{max}} = 1 \text{ s} ; t = 0.8 \geq t_v = t_{\text{max}} \times t = 1 \text{ s} \times 0.8 = 0.8 \text{ s}$$

**2. Example:**

$$t_{\text{max}} = 2 \text{ s} ; t = 0.4 \geq t_v = t_{\text{max}} \times t = 2 \text{ s} \times 0.4 = 0.8 \text{ s}$$

**Repeat accuracy**

The repeat accuracy of the delayed contact depends on different factors:

Repeat accuracy  $t_w = \text{system reaction time}^1 \pm 1 \% \text{ of } t_v$

<sup>1)</sup> Pick up or drop off time depending on delay mode

**Input**

**Nominal voltage  $U_N$ :** DC 24 V  
**Voltage range:** 0.8 ... 1.1  $U_N$   
**Nominal consumption:** typ. 3.2 W  
**Short-circuit protection:** Internal PTC  
**Overvoltage protection:** Internal VDR  
**Duty-cycle ON button:**  $0.1 \text{ s} < t_{\text{EIN}} < 3 \text{ s}$   
**Duty-cycle Reset button:**  $> 3 \text{ s}$

**Safety function**

**Safety mat / safety edge (4)**  
 max. permitted  
 safety edge contact resistance: 1000  $\Omega$   
 switching current at short circuit: typ. 15 mA at  $U_N$

**Light curtains (8)**

control current via S12, S22: typ. 8 mA at  $U_N$   
 Min. voltage on terminals  
 S12, S22 when relay activated: DC 10 V

**Output**

**Contacts** 2 NO instantaneous contacts  
 2 NO delayed contacts

The NO contacts can be used for safe braking.

**Delay  $t_v$**

ranges at /\_ \_ 0:  
 8 time ranges in one unit (seconds or minutes) settable via rotational switch  
 0.1 ... 1            1.0 ... 10  
 0.2 ... 2            3.0 ... 30  
 0.3 ... 3            10 ... 100  
 0.5 ... 5            30 ... 300  
 other times on request  
 fixed at /\_ \_ 1:  
 seconds or minutes  
 1, 2, 3, 5, 10, 30, 100, 300  
 other times on request

**Time setting in:**

**10% steps of max. time range value**

Repeat accuracy: see formula

**Thermal current  $I_{\text{th}}$ :** max. 8 A  
 (see quadratic total current limit curve)

**Safety function**

**E-Stop (1) (6), Safety gate (2) (7), Exclusive or contacts (5)**

Start up at  $U_N$ : < 65 ms  
 Release delay at  $U_N$  and disconnecting the supply: < 40 ms  
 Release delay at  $U_N$  and disconnecting S12,S22: < 60 ms

**Two-hand control (3)**

Start up at  $U_N$ : < 110 ms  
 Release delay at  $U_N$  and disconnecting the supply: < 40 ms  
 Release delay at  $U_N$  and disconnecting S12,S22: < 60 ms  
 simultaneity demand: max. 0,5 s

**Safety mat (4)**

Start up at  $U_N$ : < 85 ms  
 Release delay at  $U_N$  and disconnecting the supply: < 40 ms  
 Release delay at  $U_N$  and disconnecting S12,S22: < 60 ms

**Light curtains (8)**

Start up at  $U_N$ : < 35 ms  
 Release delay at  $U_N$  and disconnecting the supply: < 40 ms  
 Release delay at  $U_N$  and disconnecting S12,S22: < 25 ms

## Technical Data

### Switching capacity

to AC 15		
NO contacts:	3 A / AC 230 V	IEC/EN 60 947-5-1
to DC 13		
NO contacts:	2 A / DC 24 V	IEC/EN 60 947-5-1

### Electrical life

at 5 A, AC 230 V  $\cos \varphi = 1$ :  $> 1.5 \times 10^5$  switching cycles

### Permissible operating frequency

instantaneous contact:	max. 1800 switching cycles / h
delayed contact:	max. 360 switching cycles / h

### Short circuit strength

max. fuse rating: 6 A gL IEC/EN 60 947-5-1

**Mechanical life:**  $10 \times 10^6$  switching cycles

### Semiconductor monitoring output

<b>(not safety):</b>	1 for instantaneous contact
	1 for delayed contact
	max. 50 mA DC 24 V, plus switching

## General Data

**Nominal operating mode:** continuous operation

### Temperature range

Operation:	- 15 ... + 55 °C
Storage:	- 25 ... + 85 °C

**Altitude:** < 2.000 m

### Clearance and creepage distance

rated impulse voltage / pollution degree:	4 kV / 2	IEC 60 664-1
--	----------	--------------

### EMC

Electrostatic discharge (ESD):	8 kV (air)	IEC/EN 61 000-4-2
HF irradiation:	10 V / m	IEC/EN 61 000-4-3
Fast transients:	2 kV	IEC/EN 61 000-4-4

Surge voltage  
between

wires for power supply:	1 kV	IEC/EN 61 000-4-5
between wire and ground:	2 kV	IEC/EN 61 000-4-5
HF-wire guided:	10 V	EN 61 000-4-6

**Interference suppression:** Limit value class B EN 55 011

### Degree of protection

Housing:	IP 40	IEC/EN 60 529
Terminals:	IP 20	IEC/EN 60 529

**Housing:** thermoplastic with VO behaviour  
according to UL subj. 94

**Vibration resistance:** Amplitude 0,35 mm  
Frequency 10 ... 55 Hz, IEC/EN 60 068-2-6

**Climate resistance:** 15 / 055 / 04 IEC/EN 60 068-1

**Terminal designation:** EN 50 005

**Wire connection:** DIN 46 228-1/-2/-3/-4

### Terminal block with screw terminal

Cross section: 1 x 0.25 ... 2.5 mm<sup>2</sup> solid oder  
stranded ferruled (isolated) or  
2 x 0.25 ... 1.0 mm<sup>2</sup> solid or  
stranded ferruled (isolated)

Insulation of wires or  
sleeve length: 7 mm

### Terminal block with cage clamp terminals

**PC**  
Cross section: 1 x 0.25 ... 2.5 mm<sup>2</sup> solid or  
stranded ferruled (isolated)

Insulation of wires or  
sleeve length: 10 mm

**PT**  
Cross section: 1 x 0.25 ... 1.5 mm<sup>2</sup> solid or  
stranded ferruled (isolated)

Insulation of wires or  
sleeve length: 8 mm

**Wire fixing:** captive slotted screw  
or cage clamp terminals

**Mounting:** DIN rail IEC/EN 60 715

**Weight:** approx. 250 g

## Dimensions

### Width x height x depth:

UG 6960 PS:	22.5 x 110 x 120.3 mm
UG 6960 PC, PT:	22.5 x 120 x 120.3 mm

## Technical Data

### Safety Related Data

#### Values according to EN ISO 13849-1:

Category:	4	
PL:	e	
MTTF <sub>d</sub> :	133.3	a
DC <sub>avg</sub> :	99.0	%
d <sub>op</sub> :	365	d/a (days/year)
h <sub>op</sub> :	24	h/d (hours/day)
t <sub>cycle</sub> :	3600	s/cycle
	≅ 1	/h (hour)

#### Values according to IEC/EN 62061 / IEC/EN 61508 / IEC/EN 61511:

SIL CL:	3	IEC/EN 62061
SIL:	3	IEC/EN 61508 / IEC/EN 61511
HFT <sup>1)</sup> :	1	
DC <sub>avg</sub> :	99.0	%
SFF:	99.6	%
PFH <sub>D</sub> :	3.94E-10	h <sup>-1</sup>
PFD:	3.31E-05	
T <sub>1</sub>	20	a (year)

<sup>1)</sup> HFT = Hardware failure tolerance



The values stated above are valid for the standard type.  
Safety data for other variants are available on request.

The safety relevant data of the complete system has to be  
determined by the manufacturer of the system.

## UL-Data

**The safety functions were not evaluated by UL. Listing is accomplished according to requirements of Standard UL 508, "general use applications"**

### Switching capacity:

Ambient temperature 55°C Pilot duty B300, Q300  
5A 250Vac Resistive or G.P.  
5A 24Vdc Resistive

Ambient temperature 40°C: Pilot duty B300, Q300  
8A 250Vac Resistive or G.P.  
8A 24Vdc G.P.

### Wire connection::

60°C / 75°C copper conductors only  
PS-terminal: AWG 28 - 12 Sol/Str Torque 0.5 Nm  
PC-terminal: AWG 24 - 12 Sol/Str  
PT-terminal: AWG 24 - 16 Sol/str



**Technical data that is not stated in the UL-Data, can be found in the technical data section.**

## Standard Type

UG 6960.04PS/100/61 DC24V 300 s  
 Article number: 0065424

- Safety function: e-stop
- Delay function: adjustable
- Time delay: adjustable
- Output: 2 NO contacts instantaneous contacts  
2 NO contacts delayed contacts

- Nominal voltage: DC 24 V
- Width: 22.5 mm

## Ordering Example

UG 6960 .04 / / / /61 DC 24 V 300 s

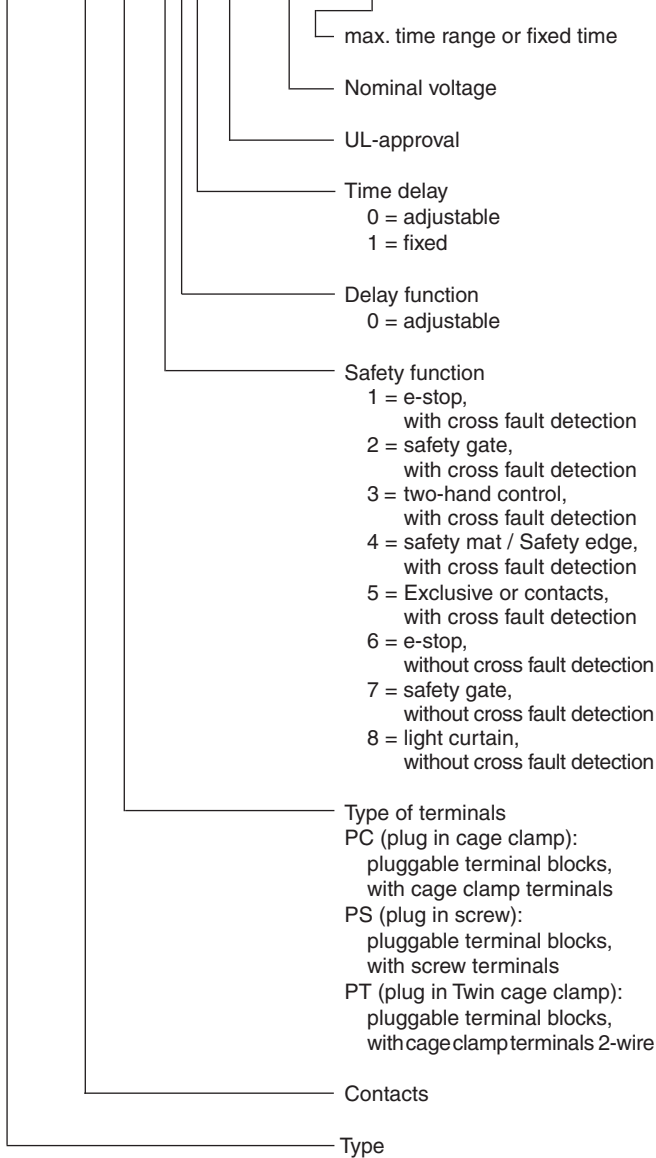

## Characteristics

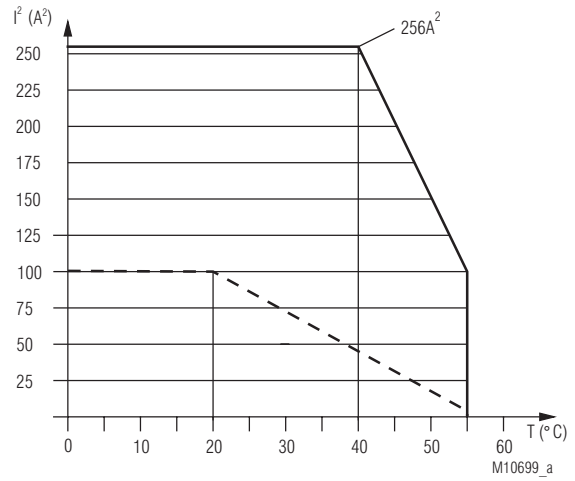

$$\Sigma I^2 = I_1^2 + I_2^2 + I_3^2 + I_4^2$$

$I_1, I_2, I_3, I_4$  - current in contact paths

## Quadratic total current limit curve output contacts

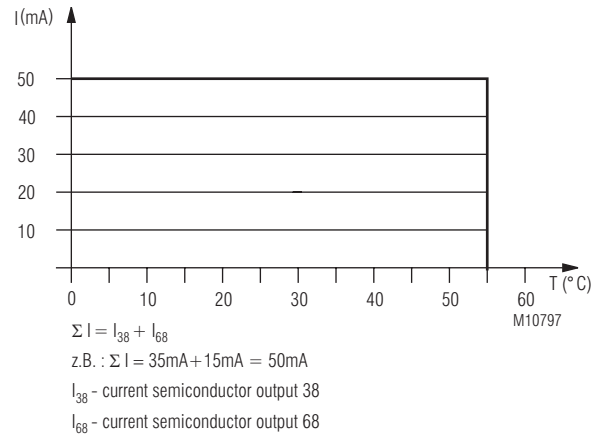

## Quadratic total current limit curve semiconductor monitoring outputs

## Options with Pluggable Terminal Blocks

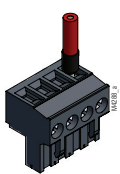

Screw terminal  
(PS/plugin screw)

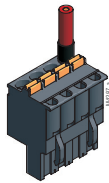

Cage clamp terminal  
(PC/plugin cage clamp)

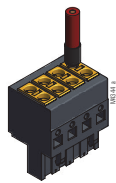

TWIN Cage clamp terminal  
(PT/plugin TWIN cage clamp)

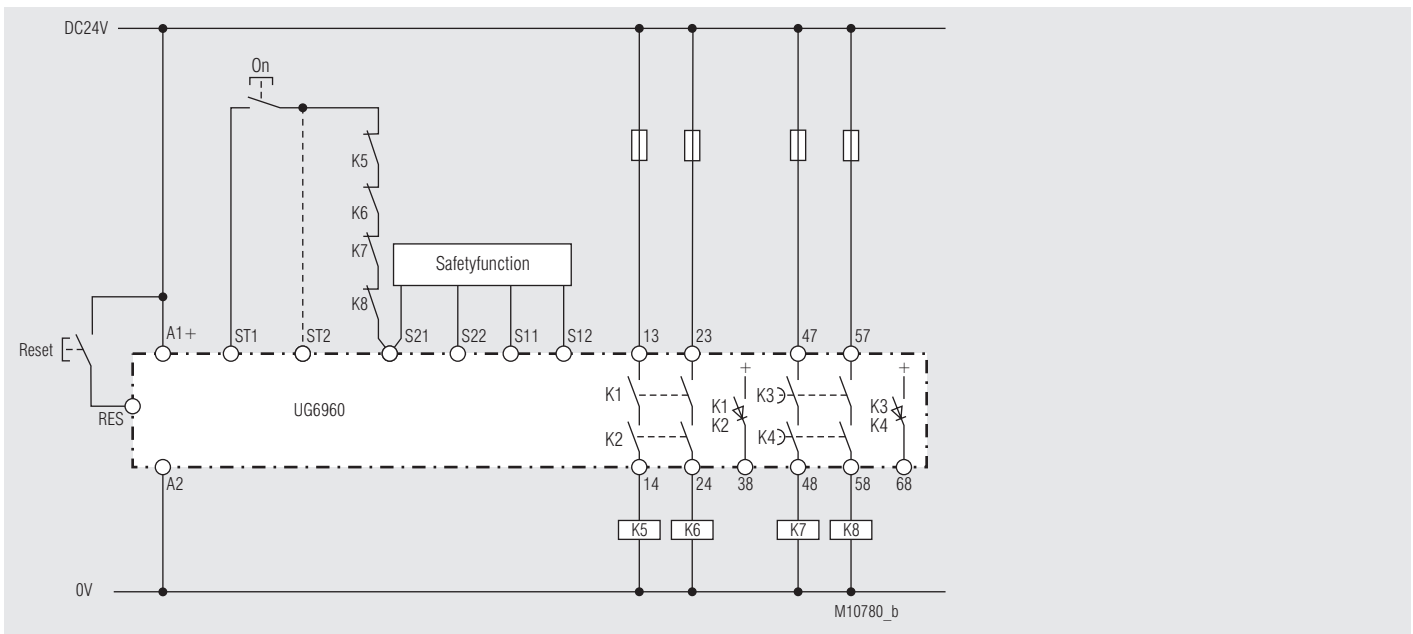

Safetyfunction: see below, Manual-Start (for automatic start make a bridge to ST2 instead of ON button).

Delay function: release delay (1)

K1/K2 instantaneous contact, K3/K4 delayed contact

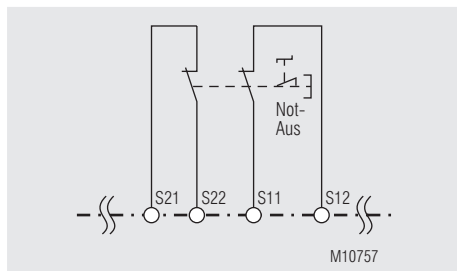

Fct.: E-stop (1),  
with cross fault detection  
SIL 3, PL e, Cat. 4

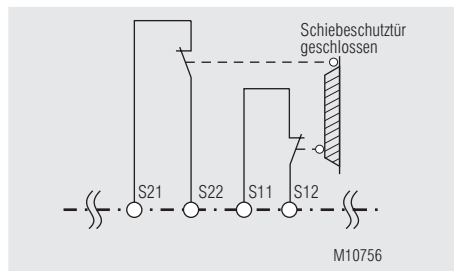

Fct.: Safety gate (2),  
with cross fault detection  
SIL 3, PL e, Cat. 4

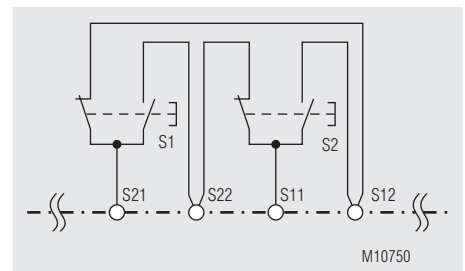

Fct.: Two-hand control (3),  
with cross fault detection  
SIL 3, PL e, Cat. 4  
Type III C to EN 574

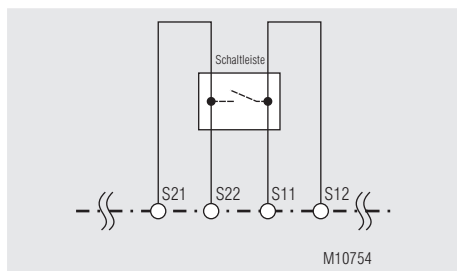

Fct.: Safety mat / Safety edge (4),  
with cross fault detection  
SIL 3, PL e, Cat. 4

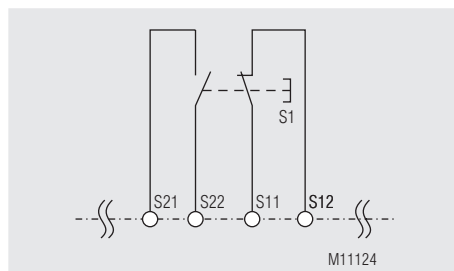

Fct.: Exclusive or contacts (5),  
with cross fault detection  
SIL 3, PL e, Cat. 4

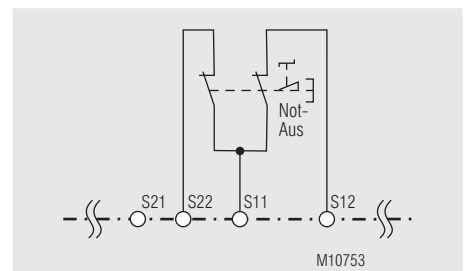

Fct.: E-Stop (6),  
without cross fault detection  
SIL 3, PL e, Cat. 4 <sup>1)</sup>

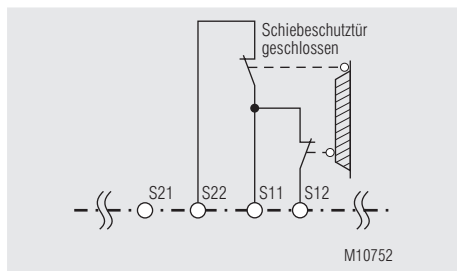

Fct.: Safety gate (7),  
without cross fault detection  
SIL 3, PL e, Cat. 4 <sup>1)</sup>

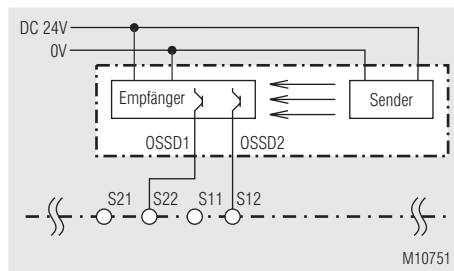

Fct.: Light curtain (8),  
without cross fault detection  
SIL 3, PL e, Cat. 4 <sup>2)</sup>

<sup>1)</sup> To achieve the stated safety classification the wiring has to be done with crossfault monitoring.  
<sup>2)</sup> To achieve the stated safety classification light curtains with selftest (type 4) according to IEC/EN 61496-1 have to be used.