

USER'S MANUAL

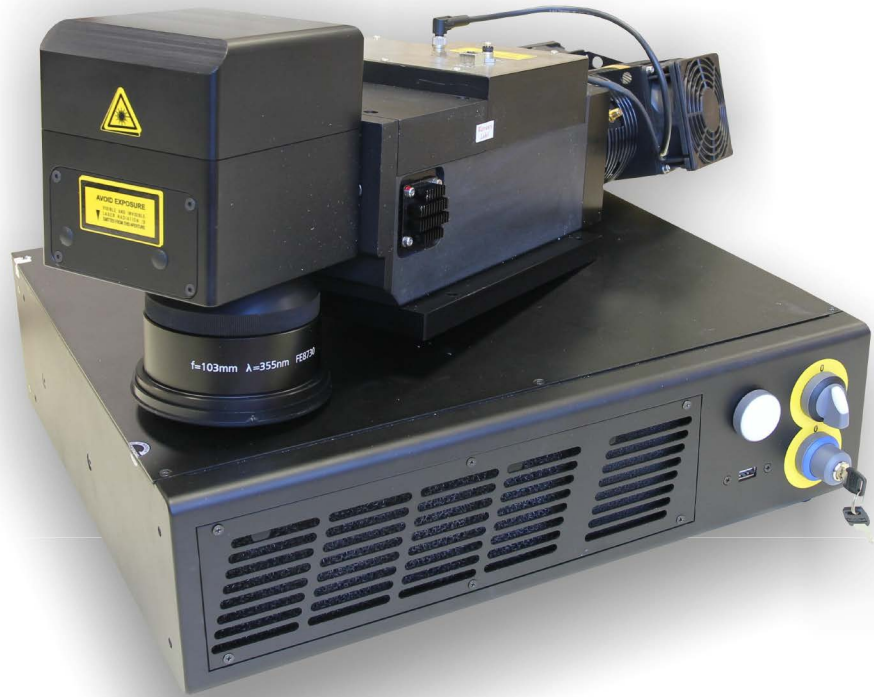

> VLASE™ UV



Datalogic S.r.l.
Via S. Vitalino 13
40012 – Calderara di Reno
Italy

Vlase™ UV User's Manual

Ed.: 05/2017

Helpful links at www.datalogic.com: **Contact Us, Terms and Conditions, Support.**

© 2014 - 2017 Datalogic S.p.A. and/or its affiliates • ALL RIGHTS RESERVED. • Without limiting the rights under copyright, no part of this documentation may be reproduced, stored in or introduced into a retrieval system, or transmitted in any form or by any means, or for any purpose, without the express written permission of Datalogic S.p.A. and/or its affiliates. Datalogic and the Datalogic logo are registered trademarks of Datalogic S.p.A. in many countries, including the U.S.A. and the E.U.

Vlase, Arex, Eox, Violino, Lighter Suite are trademarks of Datalogic S.p.A. and/or affiliates. All other trademarks and brands are property of their respective owners.

Datalogic reserves the right to make modifications and improvements without prior notification.

Datalogic shall not be liable for technical or editorial errors or omissions contained herein, nor for incidental or consequential damages resulting from the use of this material.

821002863 rev. C

SYMBOLS

Symbols used in this manual along with their meaning are shown below. Symbols and signs are repeated within the chapters and/or sections and have the following meaning:



Generic Warning:

This symbol indicates the need to read the manual carefully or the necessity of an important maneuver or maintenance operation.



Electricity Warning:

This symbol indicates dangerous voltage associated with the laser product, or powerful enough to constitute an electrical risk. This symbol may also appear on the marking system at the risk area.



Laser Warning:

This symbol indicates the danger of exposure to visible or invisible laser radiation. This symbol may also appear on the marking system at the risk area.



Fire Warning:

This symbol indicates the danger of a fire when processing flammable materials. Because there is a danger of fire, it is indispensable to follow the instructions provided by the manufacturer when commissioning the marking system.



Notice:

Notes, usage tips, or additional information.



Note:

Carefully read the user's manual before using the marking system.

REVISION INDEX

Revision	Date	Number of added or edited pages
821002860	10-03-2015	Release
821002861 rev.A	15-01-2016	General Review
821002862 rev.B	29-04-2016	Appendix C
821002863 rev.C	22-05-2017	ii, Appendix F



NOTE:

We sometimes update the documentation after original publication. Therefore, you should also review the documentation at www.datalogic.com for updates.

FOREWORD

Information included in this manual is intended for a *qualified installer* able to integrate the marking system into a system, complying with all the protection features required by international rules and local legislations. Refer to the Appendices for further information.

Following manual refers to an VLASE™ 3PWX-TLS2 system in Class 4 configuration.

In addition to being professionally trained in their role, personnel assigned to work on the marking system must be informed and made acquainted with the risks inherent to invisible and visible laser radiation. The operator is required to carefully read the section of the manual concerning safety instructions as well as the sections related to matters falling under her/his responsibility.

The workers assigned to the marking system can be identified as:

- **OPERATOR**

responsible for loading elements to be processed, visually checking the work cycle, removing the finished product and cleaning the marking system.

- **MAINTENANCE WORKER**

responsible for the electrical, mechanical and optical maintenance and adjustment of the marking system.



WARNING!

Datalogic shall not be held responsible for any non-conforming use of the marking system of its manufacture.



NOTE:

BEFORE INSTALLING AND USING THE MARKING SYSTEM, READ CAREFULLY THE APPENDICES.

OVERVIEW

We are honoured by your choice of a Datalogic product, specifically a new product belonging to the Vlase™ product families, which aim to satisfy new market evolutions, and especially the integration industrial laser sources.

OPERATION OF A LASER SYSTEM WITH GALVANOMETRIC SCANNING

The laser generates a train of high-energy pulses of invisible radiation. In order to obtain a more accurate focus, the laser beam is first enlarged using an optical expansion system and then deflected by a scanning system consisting of two mirrors mounted on galvanometric motors. These mirrors deflect the beam in a controlled beam along the X and Y axes; processing of the product surface occurs by coordinating the movement of the two motors with the turning on/off of the laser beam. The deflected laser beam is focused by an F-Theta objective before it hits the surface of the product. Generally speaking, the marking is carried out within the focus of the beam.

MARKING SOFTWARE

The marking software Lighter is preinstalled on the system.



NOTE:

Consult Lighter software user's manual for a proper use of the same.



NOTE:

Consult the proper Appendix to upgrade the preinstalled software if necessary.

The **Vlase™** laser marking system features a control unit whose size is compatible with the standard 19" 2,5U in varnished steel, and a resonator whose compact dimensions make it easy to integrate into a system that comprises safety devices required by applicable regulations, the management of marking signals and the customer's complementary modules, if any.

All laser marking system connections are found on the rear of the rack: power supply, safety, electrical signals, communication ports, patch cord to the scanner head, while the front features key and enable command devices, status LED in addition to a USB connector for the communication with the internal embedded controller.

Vlase™ belongs to the family of DPSS (Diode Pump Solid State) laser sources in the "end pumped" and "Q-Switched" configuration.

The mechanical and electrical characteristics satisfy standardization and connectivity needs of the industrial field, such as the new 19" rack and different solutions for laser system control.

The new marking system control platform allows for an easy integration in industrial environments and complies with the standard of the other Datalogic marking systems, with the same philosophy implemented in Arex™.

Based on the optical layout of the Datalogic Violino™ laser source, the Vlase™ family guarantees significant improvements in terms of performances thanks to the new laser diode current and temperature controllers, developed by the Datalogic laboratories, which short warm-up time and improve the stability of emitted laser power. The operating temperature range has been extended to 5°- 40°C for its use in industrial environments.



WARNING!

Marking system installation in secure environment is responsibility of the system integrator!



Figure 1: Control rack and resonator with scan head.

Main features:

- 100 to 240 V AC @ 50-60 Hz Power Supply
- Operating Temperature Range extended to 40°C
- Fully integrated marking and system control
- Integrated PC embedded and marking software for stand-alone operation
- Ease of integration in industrial environments and maximum control compatibility with other marking platforms (Arex™/Eox™)
- Integrated photocell and encoder connectors for Marking ON Fly (MOF) applications
- Unattended control of the system by LAN network or serial communication (RS232 protocol)
- Stable Marking process and high a beam quality ($M^2 < 1.3$)
- Compact Design: 19" 2,5U rack
- High peak power and short pulse duration (<10ns)
- Available cable lengths: 3m standard, other length available on request
- Simplified access to Laser Diode Module for fiber installation and Laser Diode Module maintenance
- Dedicated software tool for laser parameter setting and diagnostics

IMPORTANT WARNINGS

Access to the internal parts of the marking system is allowed only to authorized personnel, duly qualified and trained with regards to risks of optical and electrical nature.

Datalogic declines any and all responsibility for work carried out on live parts by untrained or unauthorized personnel.



WARNING!

It is forbidden to change the intended use for which the system was designed and developed. Datalogic declines any responsibility and liability for irregular and improper use of the laser system which it manufactures.



WARNING!

These marking system actuation is demanded to the system integrator.

TABLE OF CONTENTS

SYMBOLS	III
REVISION INDEX	IV
FOREWORD	V
OVERVIEW	VI
OPERATION OF A LASER SYSTEM WITH GALVANOMETRIC SCANNING	vi
MARKING SOFTWARE	vi
IMPORTANT WARNINGS	vii
TABLE OF CONTENTS	VIII
1 CONTENTS OF THE PACKAGING	10
1.1 UNPACKING	10
1.2 MAIN HARDWARE	11
1.3 CABLES AND OTHER COMPONENTS	11
1.4 TRANSPORT	12
1.5 ON MOISTURE CONDENSATION	12
1.6 FIXING AND POSITIONING	13
1.7 INSTALLATION ENVIRONMENT	15
1.8 FUME / DUST EXTRACTOR	16
1.9 FAN INSTALLATION	16
2 TECHNICAL SPECIFICATIONS	17
2.1 TECHNICAL CHARACTERISTICS	17
2.2 DESCRIPTION OF THE MODULES	19
2.2.1 RESONATOR	19
2.2.2 CONTROL RACK	20
2.3 MARKING AREA SPECIFICATION	21
2.4 EXTERNAL CONNECTORS SPECIFICATIONS	23
2.4.1 INTERLOCK CONNECTOR	23
2.4.2 INTERLOCK OUT CONNECTOR	25
2.4.3 COMMAND BOX CONNECTOR (LASER CONTROL)	26
2.4.4 AXES CONNECTOR (I/O CONTROL)	31
2.4.5 RS232 CONNECTOR (COM2)	32
2.4.6 ENCODER CONNECTOR	33
2.4.7 PHOTOCCELL CONNECTOR	33
2.5 INPUT/OUTPUT SIGNAL SPECIFICATIONS	34
2.6 CONNECTION EXAMPLES	35
3 INSTALLATION AND SET UP	36
3.1 CONNECTIONS	36
3.1.1 CONNECTING COMMAND BOX CABLE	36
3.1.2 CONNECTING INTERLOCK CABLE	37
3.1.3 CONNECTING INTERLOCK OUT CONNECTOR	37
3.1.4 CONNECTING THE OPTICAL FIBER TO THE CONTROL RACK	38
3.1.5 CONNECTING THE OPTICAL FIBER ON THE RESONATOR	41
3.1.6 CONNECTING RADIOFREQUENCY CABLE	43
3.1.7 CONNECTING MDR CABLE	44
3.1.8 CONNECTING RESONATOR CABLE	45
3.1.9 CONNECTING FAN CABLE	46
3.1.10 CONNECTING POWER SUPPLY CABLE	47
3.1.11 GROUND CONNECTION	47
3.1.12 CONNECTING RESONATOR POWER SUPPLY CABLE	48
3.1.13 LOCAL MODE CONNECTION	49
3.1.14 REMOTE MODE CONNECTION	50
3.1.15 F-THETA LENS PROTECTION CAP REMOVAL	51
4 USE AND OPERATION	52
4.1 TURNING ON SEQUENCE	52

4.1.1	ADVICE ON USING THE SYSTEM	55
4.2	LOCAL MODE OPERATIONS	56
4.3	REMOTE MODE OPERATIONS	56
4.4	OPERATING IN LOCAL MODE	58
4.4.1	HOW TO CREATE AND EDIT YOUR FIRST GRAPHIC DOCUMENT	59
4.4.2	HOW TO TEST AND ENGRAVE YOUR DOCUMENT	62
4.4.3	HOW TO USE EXTERNAL SIGNALS TO ENGRAVE YOUR DOCUMENT	64
4.5	THERMALIZATION AND SUPPRESSION OF GIANT PULSES	66
5	CUSTOMIZE THE SYSTEM'S SOFTWARE	68
5.1	CHANGE O.S. LANGUAGE AND KEYBOARD LAYOUT	68
5.2	CHANGE LAN CONFIGURATION AND IP ADDRESS	71
5.3	CHANGE VIDEO SETTING	74
5.4	REMOTE DESKTOP CONNECTION	76
6	ACCESSORIES	78
6.1	CONTROL BOX	78
6.2	MARKING ON FLY KIT	79
6.3	CABLE KIT LENGTH PLUS	79
6.4	RACK HANDLES	80
7	TECHNICAL SUPPORT	81
7.1	SEALS	81
7.2	MAINTENANCE	82
7.2.1	F-THETA SCAN LENS CLEANING PROCEDURE	82
7.2.2	AIR FILTER CLEANING PROCEDURE	83
7.3	PRODUCT SUPPORT AND CUSTOMER SERVICE	84
APPENDIX A:	LABELS IDENTIFICATION	85
	POSITIONING OF EXTERNAL LABELS	87
APPENDIX B:	STANDARDS	89
	LASER STANDARDS	89
	CE COMPLIANCE	89
	FCC COMPLIANCE	89
APPENDIX C:	SAFETY CONSIDERATION ACCORDING TO EN ISO 13489-1:2008	90
	PERFORMANCE LEVEL (PL)	90
	APPLICATION EXAMPLE	90
	SAFETY FUNCTIONS OF VLASE™	94
APPENDIX D:	NOTE ABOUT LASER	95
	LASER SAFETY	95
	LASER RADIATION	96
	ABSORPTION OF LASER RADIATION	97
	CLASSIFICATION AND DANGER LEVEL	97
	RADIATION VIEWING CONDITIONS	98
	DIRECT VIEWING OF THE LASER BEAM	98
	DIRECT VIEWING OF THE BEAM AFTER MIRROR REFLECTION	98
	DIRECT VIEWING OF THE BEAM OUTPUT BY AN OPTICAL FIBER	98
	DIRECT VIEWING OF THE BEAM AFTER FOCUSING	98
	SCATTERED VIEWING OF THE BEAM AFTER FOCUSING	98
	N.O.H.D. DETERMINATION AND O.D. OF PROTECTION GOGGLES	99
	EYES AND SKIN RISKS	101
	GENERAL SAFETY REGULATIONS	101
	COLLATERAL RISKS	101
APPENDIX E:	SOFTWARE UPGRADE	103
APPENDIX F:	RECOVER THE SYSTEM USING USB RECOVERY DISK	106
APPENDIX G:	MECHANICAL DRAWINGS	112
FIGURES		114

1 CONTENTS OF THE PACKAGING

1.1 UNPACKING

When unpacking the marking system from the shipping carton you should:

- Remove the documentation from the top of the marking system
- Remove the box containing the accessories
- Carefully remove the marking system from the packaging using both hands

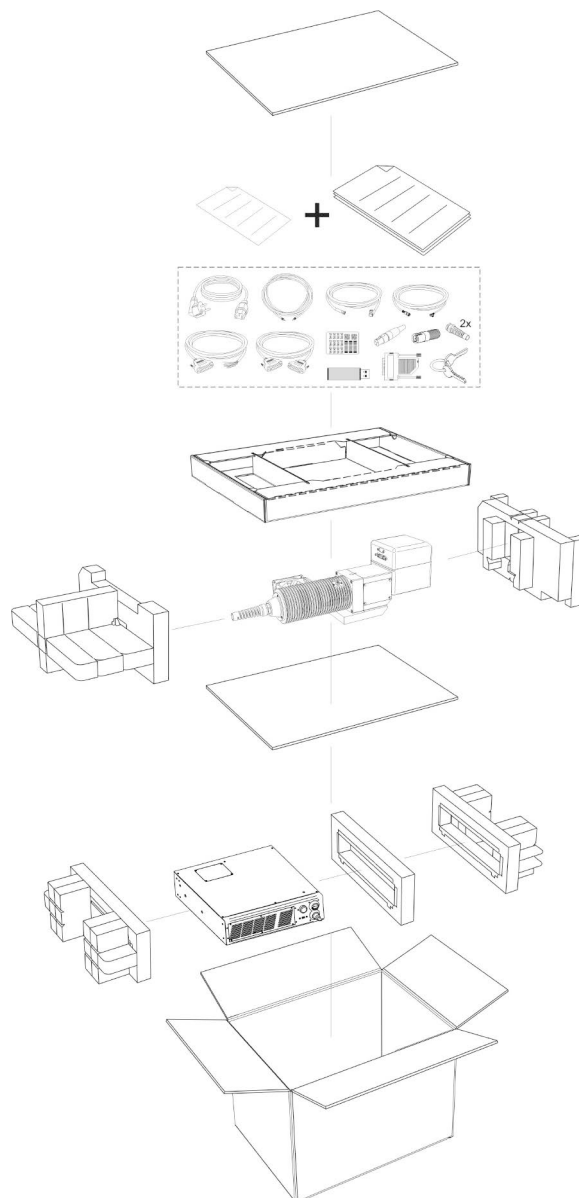

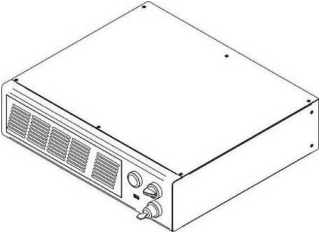
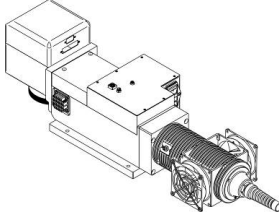

Figure 2: Unpacking.

Before installing or operating the marking system, you should:



- Inspect the shipping container for damage
- Inspect the marking system for signs of damage
- Confirm that the shipping carton contains all items on the shipping inventory list including any accessories



Retain all packaging materials until the marking system has been inspected for completeness and damage, and you have checked the operating performance. If anything is missing or defective, see chapter 7 for contact details.

1.2 MAIN HARDWARE

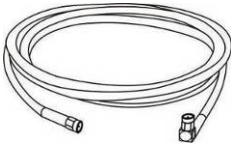

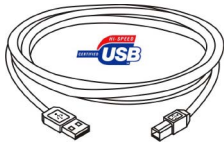
 <p>Control rack</p>	 <p>Resonator</p>	 <p>F-Theta (except 3PWX-T0SV)</p>
--	---	--

1.3 CABLES AND OTHER COMPONENTS

 <p>RF cable</p>	 <p>Resonator cable</p>	 <p>Optical fiber cable</p>	 <p>USB cable</p>
--	---	--	---

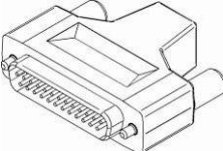
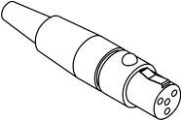
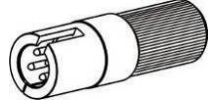
 <p>Power supply cables</p>	 <p>Scan Head cable</p>	 <p>Command Box cable</p>
--	--	--

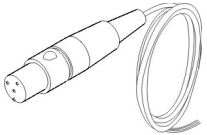
 <p>Command Box Gold connector (*)</p>	 <p>Interlock connector gold (*)</p>	 <p>Interlock OUT connector</p>
--	--	---

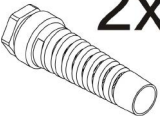
 <p>Interlock cable</p>	 <p>Safety Key</p>	 <p>USB Stick</p>	 <p>2x Cable gland</p>
---	--	--	---

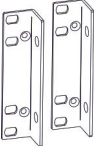
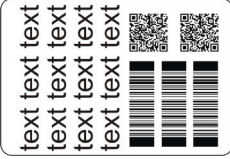
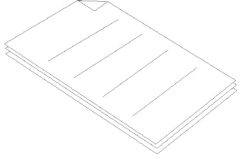
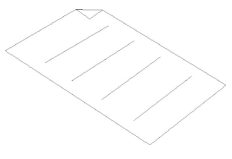
 <p>Rack adapters</p>	 <p>Sample Test</p>	 <p>User Manual</p>	 <p>Test Report</p>
---	---	--	---

* If this connector is used, the marking system works in **DANGEROUS** condition (MUTING DEVICE).

1.4 TRANSPORT

The marking system needs to be moved in order to proceed to its positioning and wiring. The marking system can't be lifted up and moved by a single person.



WARNING!

To avoid damaging or breaking the optical fiber, never subject it a bending radius below the limits specified in the technical specification table.

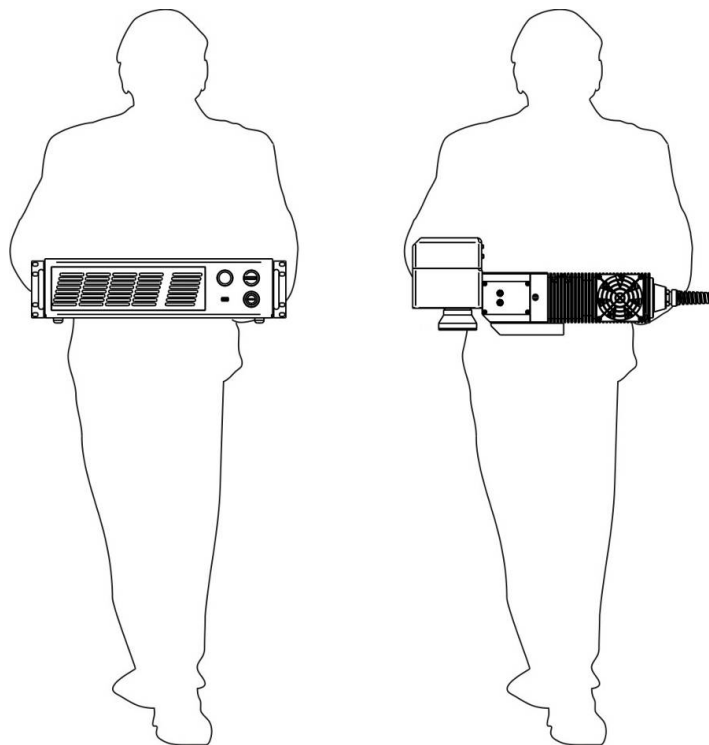

Figure 3: Transport.



WARNING!

Vlase™ is a delicate optical laser marking system, avoid damaging it with shock and vibrations.



WARNING!

Be extremely careful to not damage the fiber optic cable between resonator and rack.

1.5 ON MOISTURE CONDENSATION

If the marking system is brought directly from a cold to a warm location, moisture may condense inside or outside the marking system. This moisture condensation may cause a malfunction of the marking system.

If moisture condensation occurs

Turn off the marking system and wait about 1 hour for the moisture to evaporate.

Note on moisture condensation

Moisture may condense when you bring the marking system from a cold place into a warm place (or vice versa) or when you use the marking system in a humid place as shown below.

How to avoid moisture condensation

When you bring the marking system from a cold place into a warm place, put it in a plastic bag and seal it tightly. Remove the bag when the air temperature inside the plastic bag has reached the ambient temperature (after about 1 hour).

1.6 FIXING AND POSITIONING

The marking system must be positioned in a safely manner and the precautions listed below must be followed.

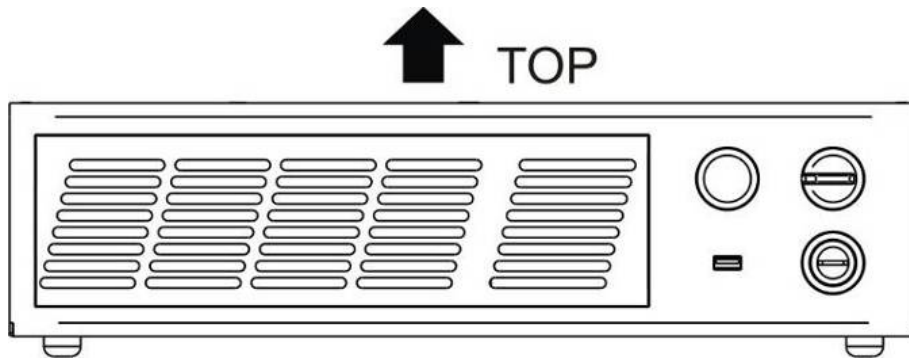
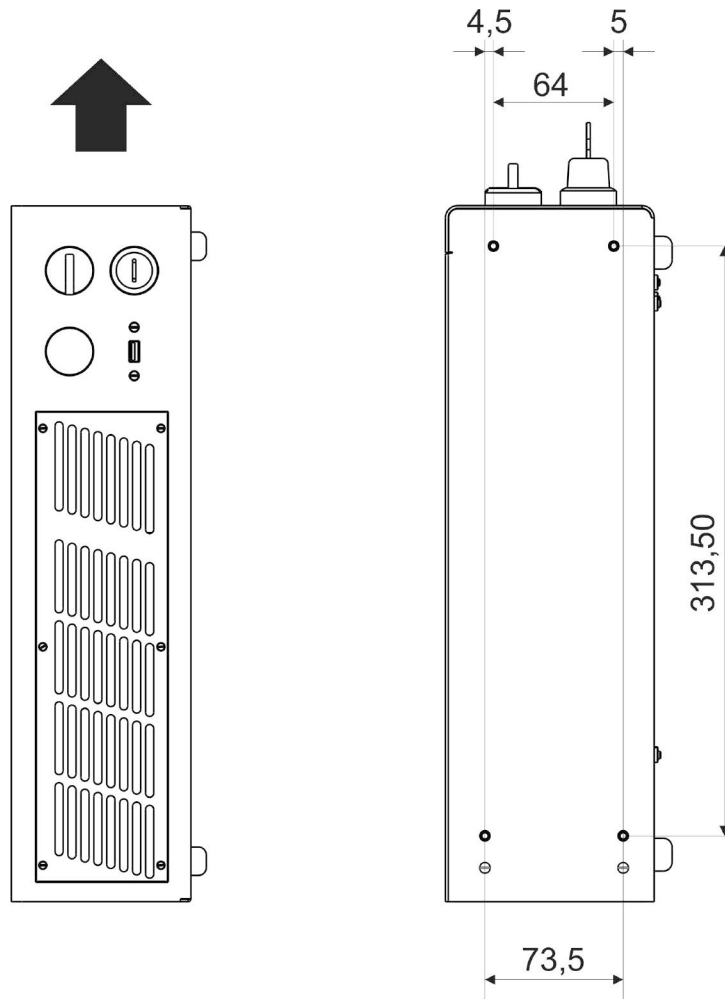

Figure 4: Positioning rack.



*: DIMENSIONS ARE IN MILLIMETRES

Figure 5: Vertical positioning (need additional fixing).



WARNING!

DO NOT fix the marking system in manner not shown in figure.

The marking system can be fitted inside a special rack cabinet equipped with special support shoulders and handles, available on request. The figure below shows the mounting points for mounting in rack:

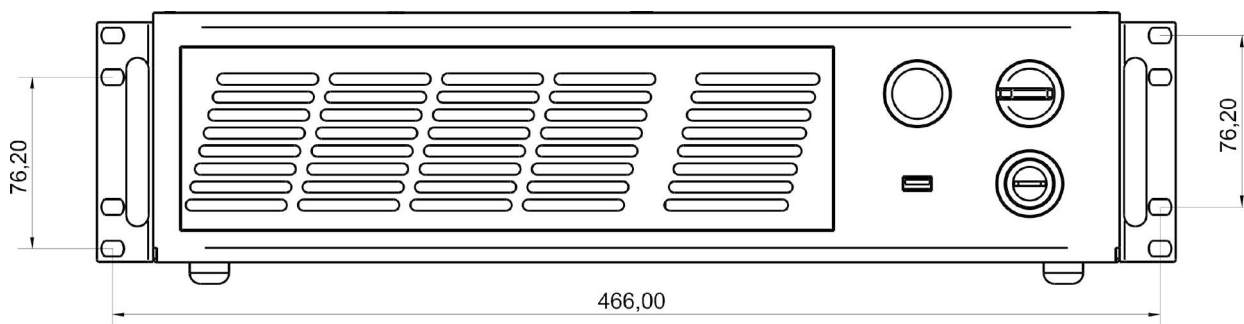

*: DIMENSIONS ARE IN MILLIMETRES

Figure 6: Fixing points on rack handles (cabinet assembly).

The resonator must be secured to a special base (not supplied by Datalogic) using the four M6 threaded holes.

The resonator, just like the control rack, must be safety positioned and secured on a special surface, parallel to the ground and absolutely vibration-free. The resonator can be secured both horizontally and vertically.



NOTE:

In order to prevent marking distortions, install a vibrometer on the base of the piece to be marked and check for the absence of vibrations during the marking process.



NOTE:

It is recommended to install the resonator on a micrometer positioning Z-axis system!

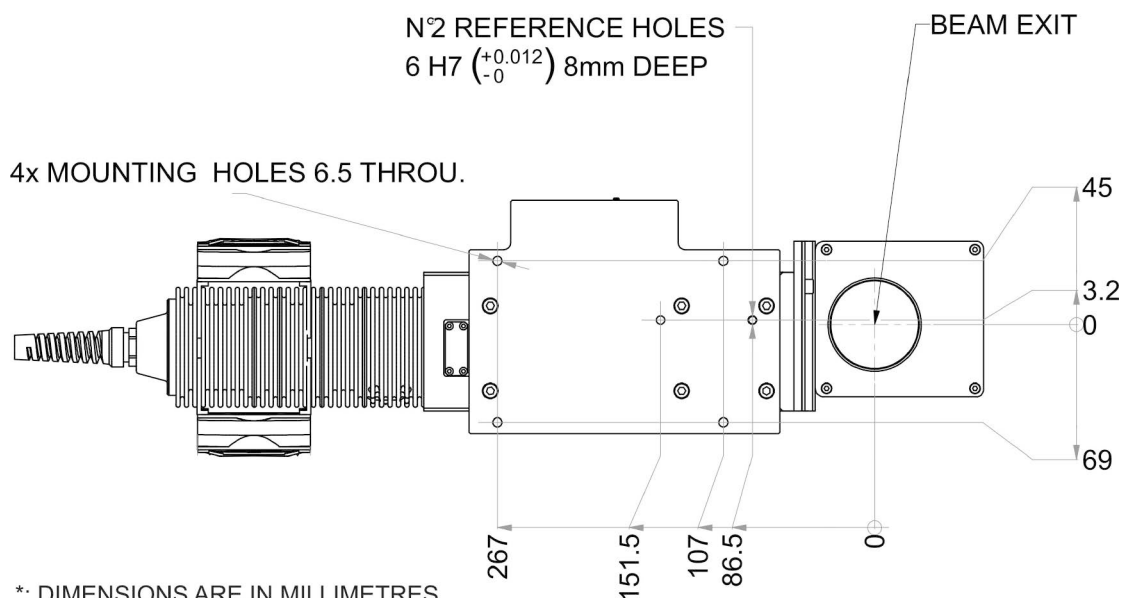

*: DIMENSIONS ARE IN MILLIMETRES

Figure 7: Resonator fixing points



WARNING!

It is very important to secure the laser system before you start marking the piece since improper securing or positioning may cause serious damage.

Do not secure the marking system in a way other than the one described in the figure.

1.7 INSTALLATION ENVIRONMENT

The control rack must be installed in a suitable environment in order to allow proper air flow passage and correct housing of the cables.

Vlase™ is an air cooled marking system: an adequate air flow is necessary to guarantee correct cooling of the system. Install must not slow or stop the flow of air cooling. Moreover, do not install a heat source near. Clean air filter when it is dirty. If the air filter is dirty, the air-flow might become not sufficient to ensure correct cooling and might stop marking operation. Clean or exchange air filter periodically.

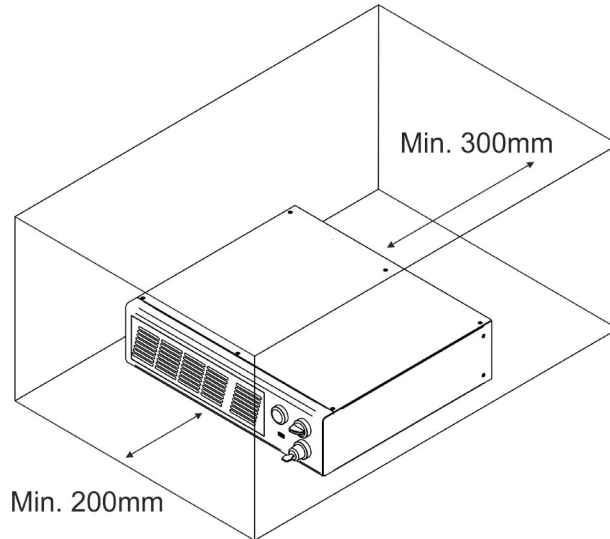

Figure 8: Rack installation environment.



WARNING!
DO NOT place heavy objects on top of rack!

In order to have the marking system operating in safety mode (see Appendices for more details) we recommended to install the marking system as shown in figure below in order to limit laser output area. To obtain a good marking quality, and not to decrease life time, we recommended a ventilation or vacuum system in a protection box to limit dust due to marking phase.

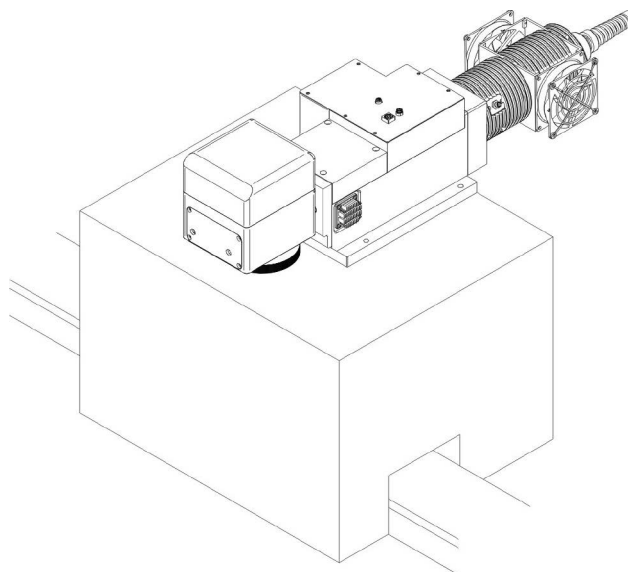

Figure 9: Safety mode example.

1.8 FUME / DUST EXTRACTOR

During marking process, dust and/or gas may be produced. It is important to use adequate fume extractor and/or air filtration.



WARNING!

Marking PVC (or other plastic material) can cause the release of chlorine gas which can be **harmful** to the laser operator and to the marking system itself. Always use adequate fume extractor during PVC and plastic marking.

1.9 FAN INSTALLATION

The fan supplied with the device must be accurately positioned and fixed on the resonator so that it can work properly.

The fan must be assembled so that the air flow is aimed at the unit containing the crystal (gold-coloured section on the resonator).

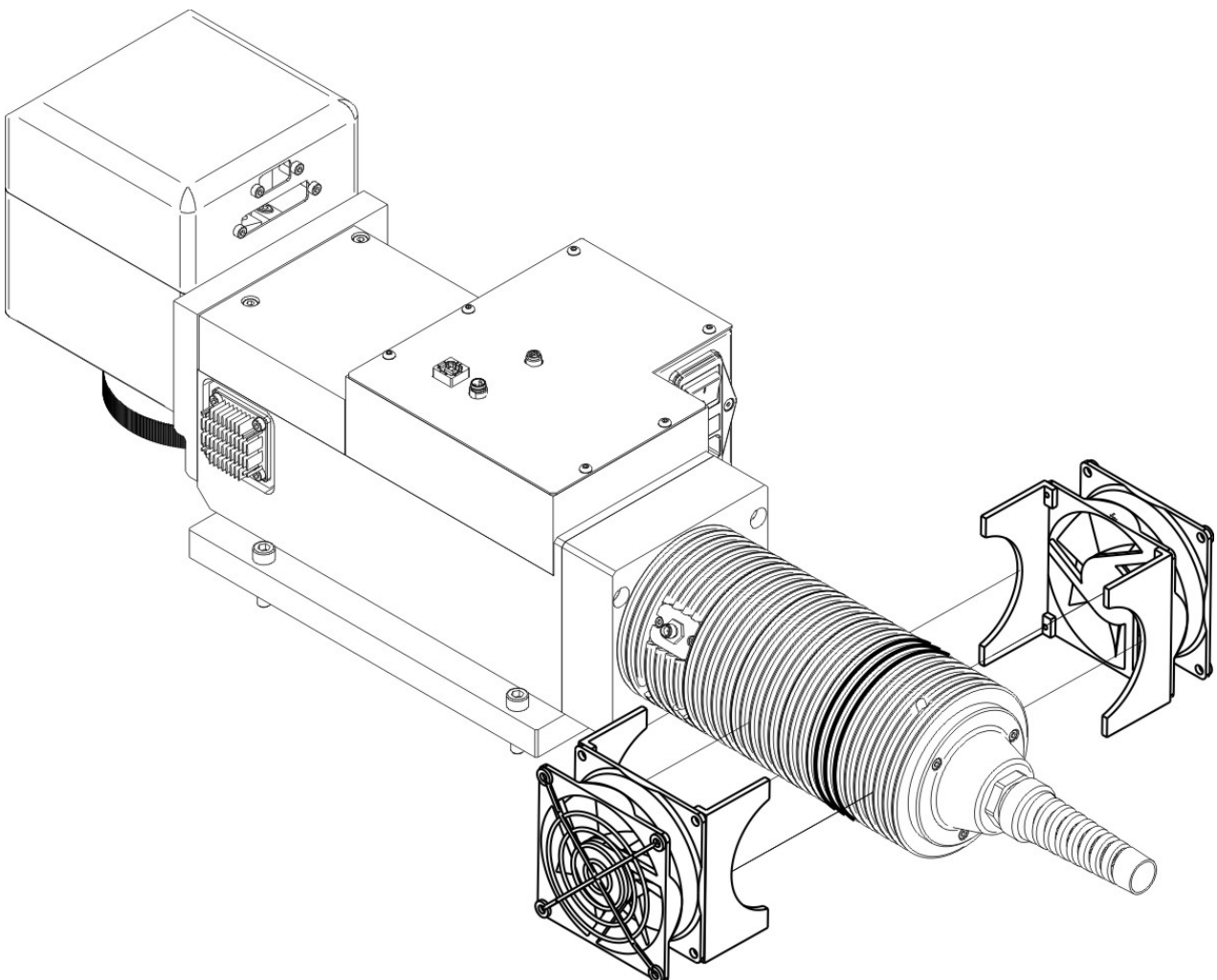

Figure 10: Fan installation.

2 TECHNICAL SPECIFICATIONS



NOTE:
BEFORE INSTALLING AND USING THE LASER, READ CAREFULLY THE APPENDICES.



WARNING!
Vlase™ is a CLASS 4 LASER PRODUCT and it is the responsibility of the OEM/system integrator to provide the safety completeness to be ready-to-use.

2.1 TECHNICAL CHARACTERISTICS

CONTROL RACK MECHANICAL CHARACTERISTICS

Weight	15 Kg
Height	122 mm
Width	430 mm
Depth	480 mm

RESONATOR WITH SCANNER HEAD MECHANICAL CHARACTERISTICS

Weight (*)	11 Kg
Height	168 mm
Width	181 mm
Depth (**)	686 mm

(*) Without F-Theta.

(**) Vary from models.



NOTE:
Refer to Datalogic's website for detailed drawings.

STORAGE AND TRANSPORTATION CONDITIONS

Storage temperature	-10° to 60°C (14° to 140°F)
Shock and vibrations	MIL 810E "CAT 1 Basic Transportation"
Package Drop Test	60 cm

**WARNING!**

This product includes precision optical parts; avoid vibration and shocks: marking quality may deteriorate.

ENVIRONMENTAL OPERATING CONDITIONS

Environmental temperature	5°C to 40°C (41° to 104°F)
Humidity	< 90% without condensation
Altitude	< 2000 m
Pollution Degree	2
Overvoltage Category	II

ELECTRICAL POWER SUPPLY

Input Voltage	100 to 240 V AC @ 50-60 Hz
Input Current	6 max
Max Power	600W

PERFORMANCES

LASER MARKER SOURCE (specification @ 25°C)		
Laser Type		Class 4 DPSSL (Diode Pumped Solid State Laser)
Average Power at reference Rep Rate (30kHz) ¹	W	3.0
Pulse energy (max)	mJ	0.10 (7ns)
Peak power (max)	kW	14
Central emission wavelength	nm	355
Repetition Rate ²	kHz	20 ÷ 80
Laser aiming beam		Class 2 <1mW @ 630-670nm
Cooling		Forced Air Rack Fans = L10 @ 40°C : 60000h Resonator Fan = L10 @ 40°C : 70000h
Noise	dB(A)	< 70 at 1 meter

OTHER		
Optical Fiber Minimum Bending Radius	mm	200 (fixed installation)
Available Cables Length	m	3 standard, other available
Marking Speed	mm/s	Up to 3000 mm/s
Char Marking Speed ³	char/s	Up to 340 char/s
MOF (Marking on the fly)		YES [constant speed or encoder]
Line speed - Productivity ⁴		Up to 75 m/min – 3 Pcs/s
Marking Control and Software		EMC Embedded Control and Lighter Suite
Communication		RS232, Ethernet (TCP/IP 10, 100 Mbit), digital I/O

¹ Without F-Theta

² Without Power derating

³ h char=1mm in roman s Level100% f=30kHz F-Theta160L on TESA label

⁴ Single line string, Roman-s font

2.2 DESCRIPTION OF THE MODULES

2.2.1 RESONATOR

A description of the main parts of the resonator unit is provided here below:

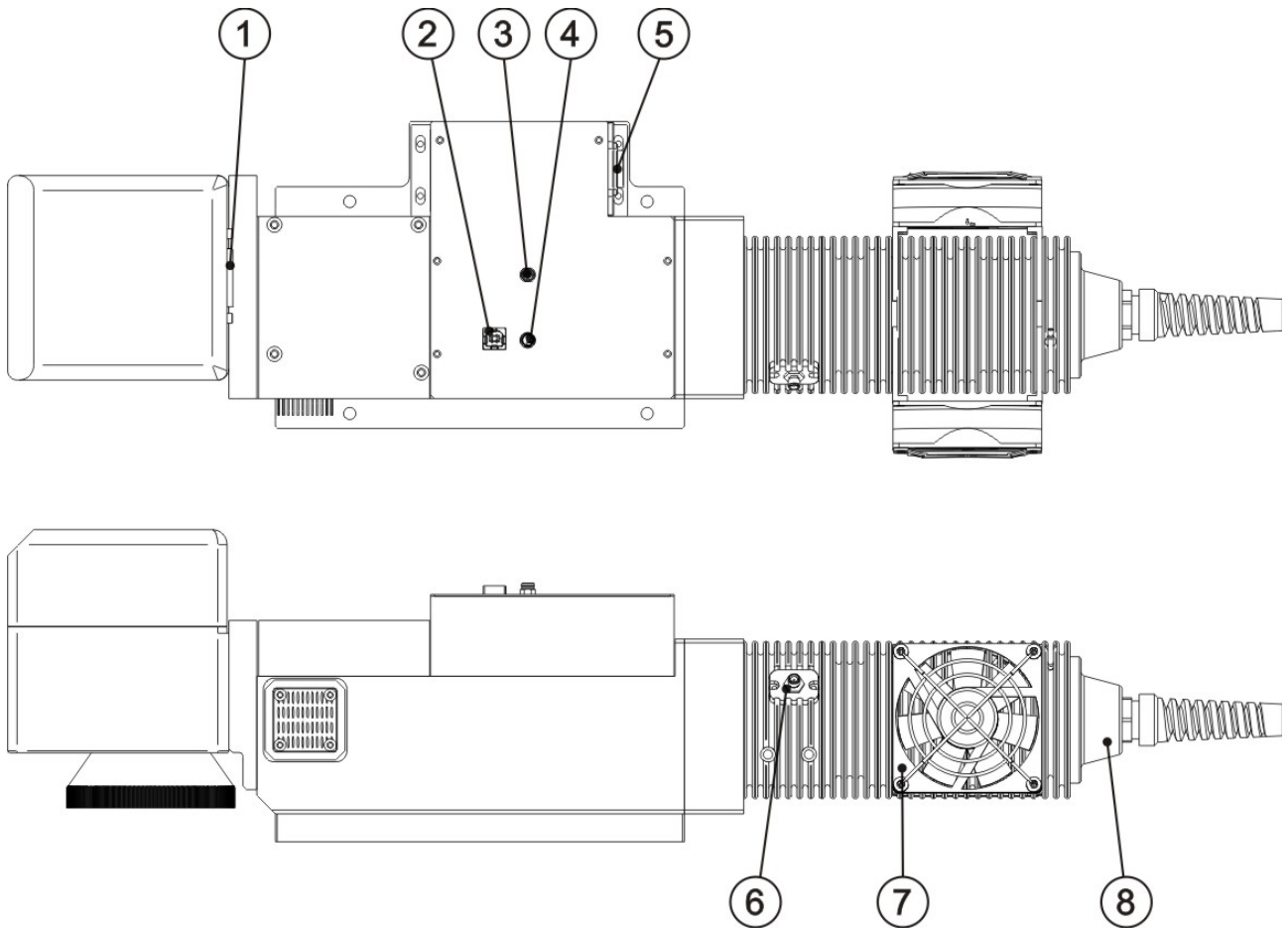

1) Scan Head signals connector	5) Resonator power supply connection
2) USB port type B	6) RF connector
3) Fan connector	7) Cooling fan
4) Rack-Resonator connector	8) Optic fiber inlet

Figure 11: Resonator view.

2.2.2 CONTROL RACK

A description of the control rack is provided here below for the purpose of obtaining the right information for proper installation of the marking system.

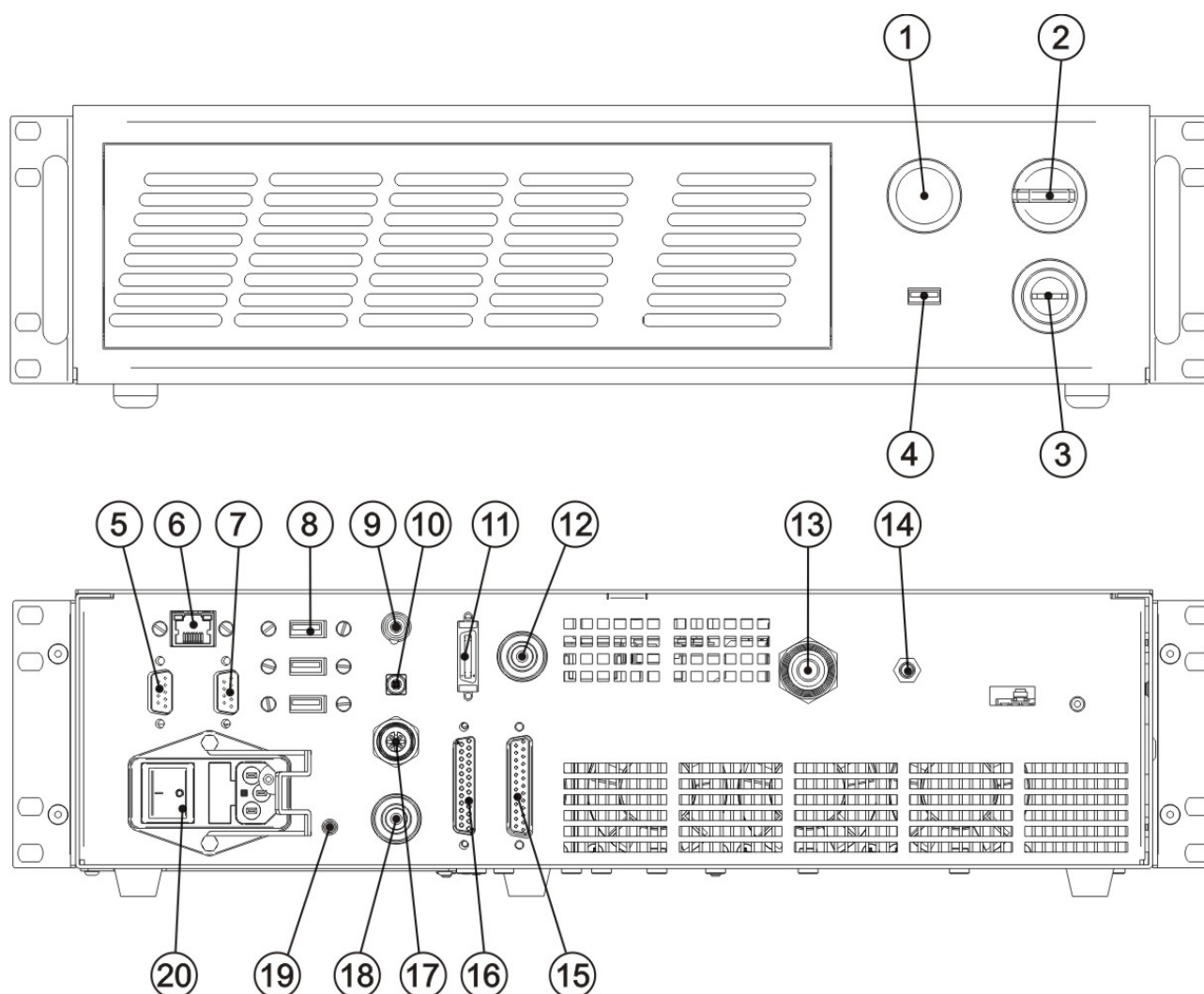

1) Status LED	11) MDR connector
2) Enable	12) Resonator signals connector
3) Key	13) Optic fiber outlet
4) USB port	14) RF connector
5) VGA port	15) Command Box connector
6) LAN port	16) I/O connector (axis control)
7) RS232 port	17) Photocell connector
8) 3x USB ports	18) Encoder connector
9) Interlock connector	19) Earth ground
10) Interlock OUT connector	20) Mains power supply connection

Figure 12: Control rack front view.

2.3 MARKING AREA SPECIFICATION

Datalogic provides a wide range of F-Theta scan lenses to be attached to the scanning head to focus the laser beam in flat Marking Field, in order to achieve high-resolution marking results.

These F-Theta scan lenses are available to best-match the object (i.e.: logo; string; 2D matrix; etc.) to be marked and fit the standard Datalogic Scanning Head; further solutions about different models of F-Theta scan lenses and scanning heads will be considered upon request.

The table below lists the standard F-Theta scan lenses currently available:

F-Theta Scan Lens diameter: M85			
F-Theta Scan Lens		<i>f</i> = 103L Telecentric	<i>f</i> = 160L
Working Distance	mm	135 ± 3	197 ± 3
Fixing Distance	mm	159 ± 4	187 ± 4
Marking Area	mm ²	60 x 60	110 x 110



NOTE:

Definition of Marking Area: *square marking field measured on black anodized aluminium plate.*



WARNING!

This product was designed to use only certain configurations of F-Theta lens and marking field. If your needs are not satisfied by current available F-Theta lens configurations please contact Datalogic for a solution. The use of other F-Theta lenses or operation outside the specified marking field for a certain F-Theta lens configuration can lead to damage of F-Theta lens, scanning head or laser source. Such damage is not covered by warranty!



WARNING!

For each F-Theta lens configuration Datalogic recommends the use of certain adapter. This adapter ensures that residual back reflections caused by F-Theta lens do not damage optics of the scanning head. The removal of such adapter or its incorrect use (for example incomplete threading, use of another F-Theta lens adapter, etc.) can lead to damage of the F-Theta lens, scanning head or laser source. Such damage is not covered by warranty!

**NOTE:**

Working Distance is defined as the distance between the center of the marking area (defined in the focal plane) and the last mechanical edge of the F-Theta Scan Lens. Refer to the following figure.

WD: Working Distance

MA: Marking Area

AB: Aiming beam

FD: Fixing Distance

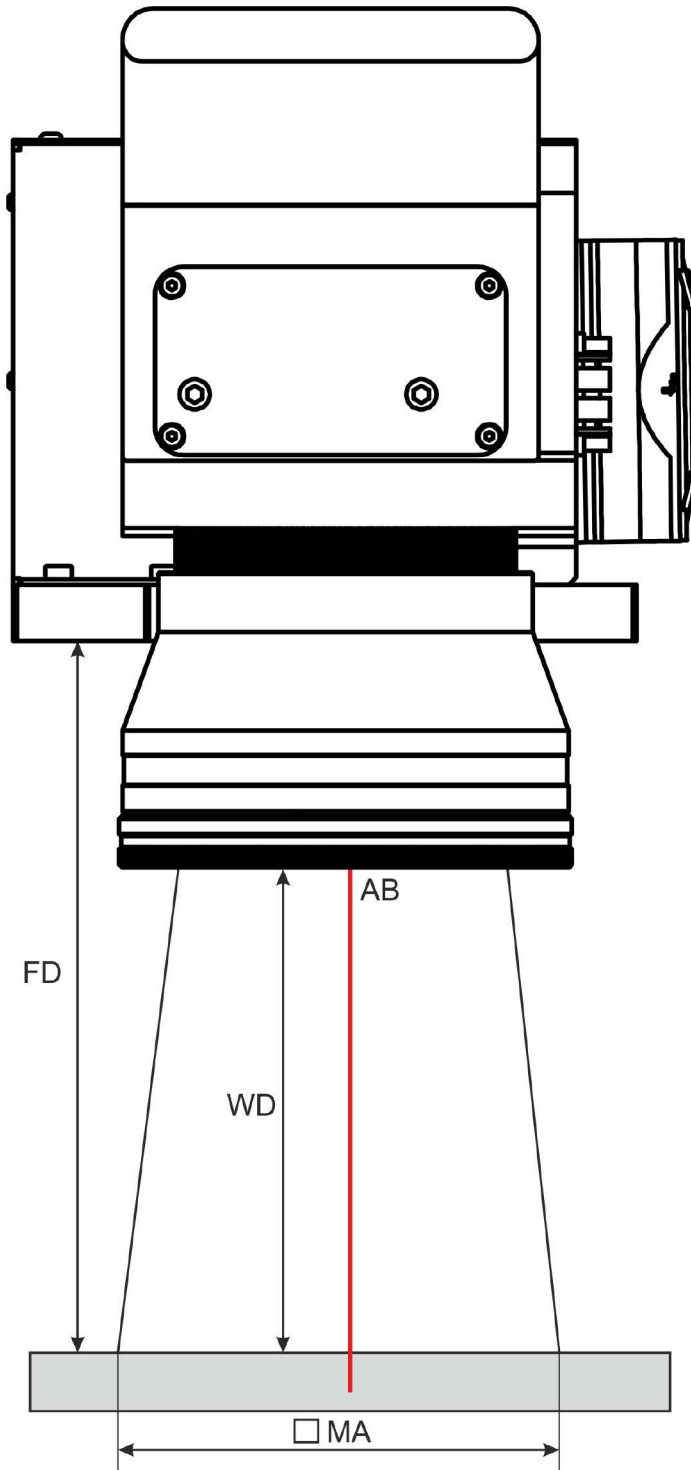

Figure 13: Marking area

2.4 EXTERNAL CONNECTORS SPECIFICATIONS

2.4.1 INTERLOCK CONNECTOR

Interlock **disables** the Class 4 laser source inside the marking system. Interlock internal circuit is designed to comply with the single fault condition.

PANEL CONNECTOR

Type SWITCHCRAFT TB Series male Tini Q-G (Mini XLR) panel mount connector, 4 positions.

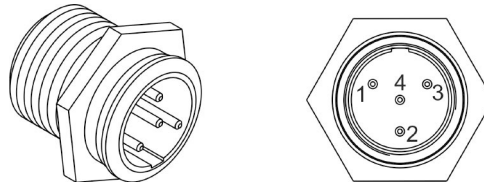

Figure 14: Male panel plug cod. TB4M (front view).

PIN	SIGNAL	TYPE	DESCRIPTION	FUNCTIONAL DIAGRAM
1	VCC_INT_IN_A	OUTPUT	24V DC reference for <i>INTERLOCK_A</i> signal	<div style="display: flex; justify-content: space-between;"> <div style="width: 45%;">USER SIDE</div> <div style="width: 45%;">SYSTEM SIDE</div> </div>
2	INTERLOCK_A	INPUT	<i>INTERLOCK_A</i> signal	
3	GND_INT_IN_B	GND	Ground reference for <i>INTERLOCK_B</i> signal	
4	INTERLOCK_B	INPUT	<i>INTERLOCK_B</i> signal	

PIN 1- PIN 2	PIN 3- PIN 4	MARKING FUNCTIONALITY	CONDITION
CONTACT OPEN	CONTACT OPEN	NOT POSSIBLE	SAFE
CONTACT CLOSED	CONTACT OPEN	NOT POSSIBLE	DANGEROUS
CONTACT OPEN	CONTACT CLOSED	NOT POSSIBLE	DANGEROUS
CONTACT CLOSED	CONTACT CLOSED	POSSIBLE	DANGEROUS



WARNING!

In order to **NOT DAMAGE** the interlock circuitry, we recommended using “dry circuit” (zero voltage) switches or relay circuitry.

PLUG CONNECTOR

Connector type SWITCHCRAFT TA Series Tini Q-G (Mini XLR) female cable mount connectors, 4 positions.

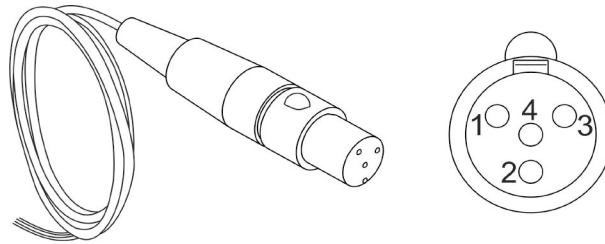

Figure 15: Female cable mount connector cod. TY4F (solder view).

**WARNING!**

If the interlock gold connector is used, the marking system is in **DANGEROUS** condition (MUTING DEVICE).

**NOTE:**

To restore the marking system it is necessary to repeat the “*Turning on sequence*” without shutting down the system. See chapter 4.1 for more details.

2.4.2 INTERLOCK OUT CONNECTOR

The interlock-out allows to monitoring of the operation of the interlock connector.

PANEL CONNECTOR

Panel socket BINDER, 4 positions female, 719 series.

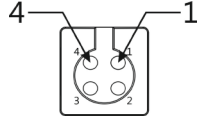
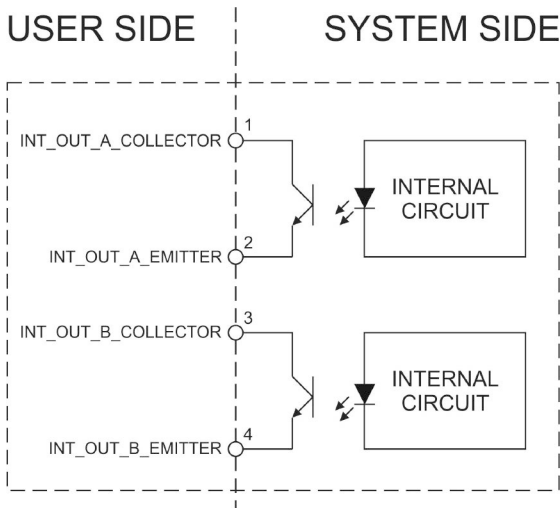

Figure 16: Female panel socket cod. 09-9766-30-04 (front view).

PIN	SIGNAL	TYPE	DESCRIPTION
1	INT_OUT_A_COLLECTOR	COLLECTOR	Interlock OUT signal A (INT_OUT_A)
2	INT_OUT_A_EMITTER	EMITTER	
3	INT_OUT_B_COLLECTOR	COLLECTOR	Interlock OUT signal B (INT_OUT_B)
4	INT_OUT_B_EMITTER	EMITTER	



INT_OUT_A	INT_OUT_B	CONDITION
Closed	Closed	SAFE
Closed	Open	DANGEROUS
Open	Closed	DANGEROUS
Open	Open	DANGEROUS

Type	NPN BJT transistor
V _{max}	300 V
I _{max}	60 mA
V _{saturation}	< 1,5 V
Leakage current	< 400 nA



NOTE:

The response time is 10 ms from the output's switching.

PLUG CONNECTOR

Binder male cable mount connectors, 719 series, 4 positions.

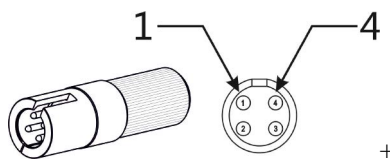

Figure 17: Male cable mount connector cod. 09-9767-00-04 (front view).

2.4.3 COMMAND BOX CONNECTOR (LASER CONTROL)

Panel socket Sub-D, 25 positions, female.

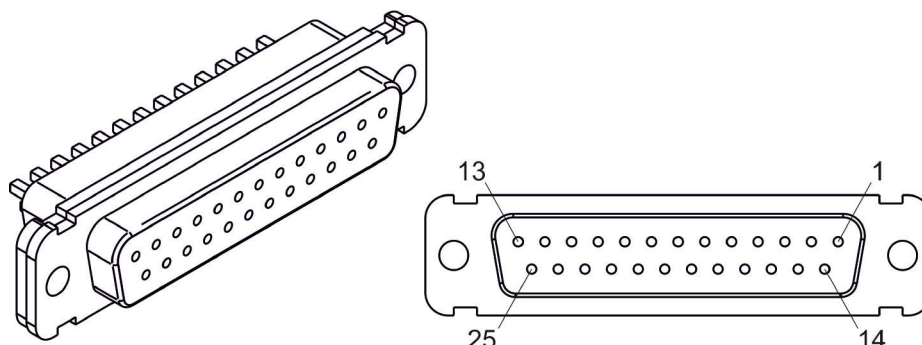

Figure 18: Female panel socket Sub-D 25 (front view).

PIN	SIGNAL	TYPE (***)	DESCRIPTION
1	12V_ENABLE_B	Output power supply	12V DC power supply available for <i>EXT_ENABLE_B</i> (max 250mA)
2	EXT_ENABLE_B	Digital Input	Secondary external <i>ENABLE</i> signal (see par. 2.4.3.1) - HIGH level: contact closed - LOW level or disconnected: contact opened
3	RESERVED	Digital Output	DO NOT CONNECT
4	EXT_12V	Output power supply	Auxiliary 12V DC power supply available for drive input logical HIGH (max 250mA)
5	EXT_12V	Output power supply	Auxiliary 12V Dc power supply available for drive input logical HIGH (max 250mA)
6	EXT_12V	Output power supply	Auxiliary 12V DC power supply available for drive input logical HIGH (max 250mA)
7	12V_ENABLE_A	Output power supply	12V DC power supply available for <i>EXT_ENABLE_A</i> (max 250mA)
8	EXT_ENABLE_A	Digital Input	Primary external <i>ENABLE</i> signal (see paragraph 2.4.3.1) - HIGH level: contact closed; - LOW level or disconnected: contact opened
9	BUSY (*)	Digital Output	This signal is used to know if the current spooler is executing (marking in progress) (see paragraph 2.4.3.4) - ON during marking process
10	CONNECTOR PRESENCE	Digital Input	This signal is used to check the presence of the command box connector (see paragraph 2.6) - HIGH level: normal operation; - LOW level or disconnected: laser source faulty
11	START MARKING (*)	Digital Input	This signal is used to start to the marking process when a document or a sequence is running in AUTO MODE (**) or WORK MODE (**): (see paragraph 2.4.3.4) - HIGH level pulsed signal start the marking process
12	EXT_KEY	Digital Input	External <i>KEY</i> signal (see paragraph 2.4.3.2) - HIGH level: contact closed; - LOW level or disconnected: contact opened
13	STOP MARKING (*)	Digital Input	This signal is used to stop the marking process (see paragraph 2.4.3.4) - HIGH level pulsed signal stop the marking process

14	RESERVED	Digital Input	DO NOT CONNECT
15	RESERVED	Digital Input	DO NOT CONNECT
16	RESERVED	Digital Input	DO NOT CONNECT
17	END	Digital Output	This signal is used to know if the marking process is finished (see paragraph 2.4.3.4): - ON at the end of marking process
18	POWER_ON	Digital Output	This signal is used to know if the system is already warmed up: (see 2.4.3.3) - ON when the laser is in <i>STAND_BY</i> or <i>READY</i> state
19	GND	Ground	Ground reference
20	SYSTEM_ALARM	Digital Output	This signal is used to know if the system is in booting up state or in error state: (see paragraph 2.4.3.3) - ON during BOOTING UP - ON in case of system error
21	GND	Ground	Ground reference
22	ENABLE_OUT	Digital Output	This signal is used to know if the system is ready to emit laser radiation: (see paragraph 2.4.3.3) - ON when the system is in <i>READY</i> state
23	SW_READY (*)	Digital Output	This signal is used to know if a document, sequence or script is loaded and ready to be executed: - ON when a document or a sequence is running in <i>AUTO MODE</i> (**) or <i>WORK MODE</i> (**) (SW_READY COMPATIBILITY (**) = true) - ON when a document or a sequence is running in <i>AUTO MODE</i> (**) and laser in <i>READY</i> state (SW_READY COMPATIBILITY (**) = false) - ON when a script is running in <i>AUTO MODE</i> (**) and "IoPort.setReady (true)" function is used
24	GND	Ground	Ground reference
25	GND	Ground	Ground reference

(*) refers to Lighter user's manual "Setting I/O parameters" paragraph to set the signal properties

(**) refers to Lighter user's manual

(***) refer to 2.5



NOTE:

Connection example in paragraph 2.6.

2.4.3.1 ENABLE SIGNAL'S SCHEME (COMMAND BOX CONNECTOR)







ENABLE		
EXT_ENABLE (A+B)*	FRONT PANEL ENABLE	
		ENABLE CONTACT IS OFF
		ENABLE CONTACT IS OFF
		ENABLE CONTACT IS OFF
		ENABLE CONTACT IS ON
* EXT_ENABLE_A	* EXT_ENABLE_B	DOUBLE ENABLE CONTACT (EN60825-1 COMPLIANT)
 PIN 8	 PIN 2	EXT_ENABLE CONTACT IS OFF
 PIN 8	 PIN 2	EXT_ENABLE CONTACT IS OFF
 PIN 8	 PIN 2	EXT_ENABLE CONTACT IS OFF
 PIN 8	 PIN 2	EXT_ENABLE CONTACT IS ON

Figure 19: ENABLE signal's scheme.

2.4.3.2 KEY SIGNAL'S SCHEME (COMMAND BOX CONNECTOR)

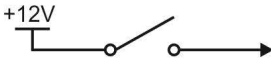
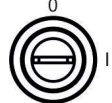
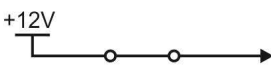
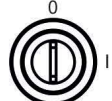
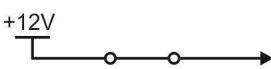
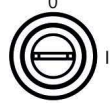
KEY		
EXT_KEY (PIN 12)	FRONT PANEL KEY	
		KEY CONTACT IS OFF
		KEY CONTACT IS OFF
		KEY CONTACT IS ON
		KEY CONTACT IS ON

Figure 20: KEY signal's scheme

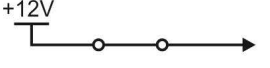
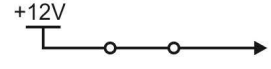
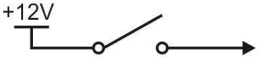
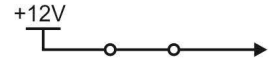
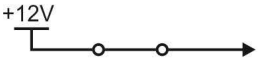
2.4.3.3 LASER CONTROL SIGNALS TIMING

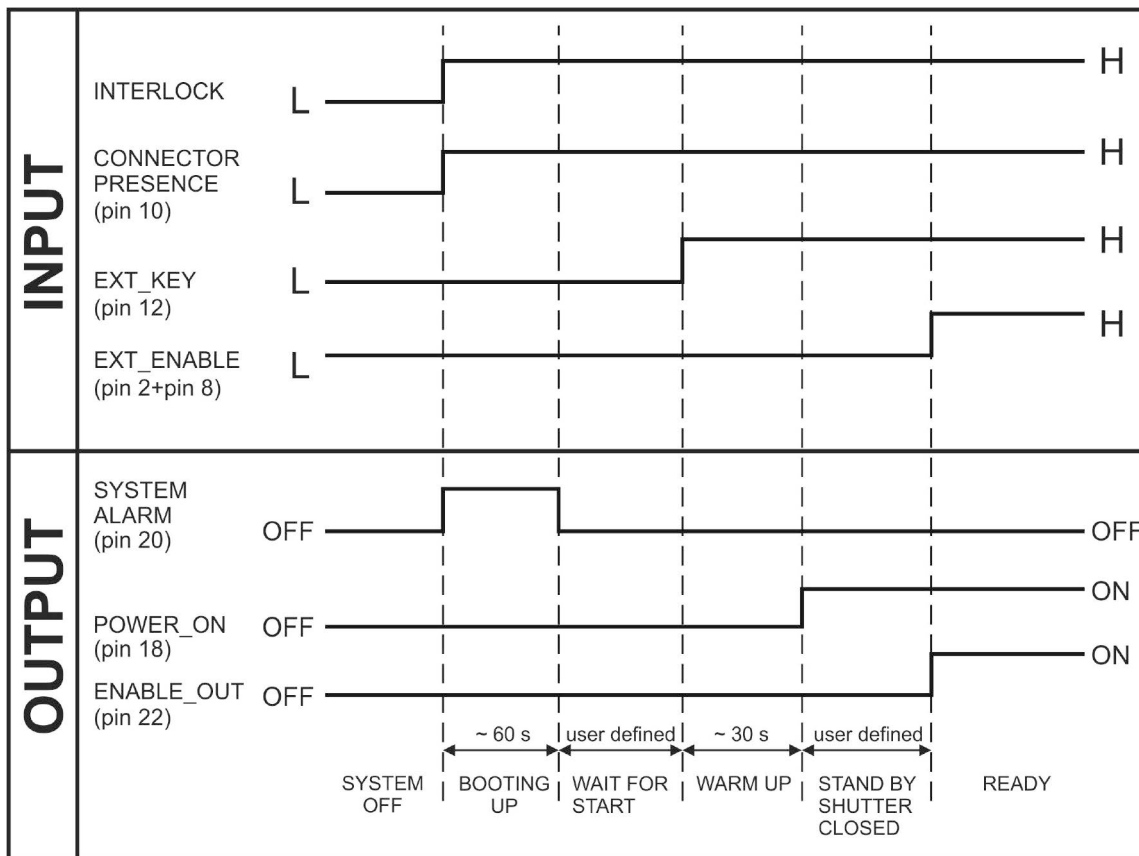

Figure 21: Timing control signals

2.4.3.4 TIMING MARKING PROCESS SIGNALS

The following diagram illustrates the possible timings and settings of these signals:

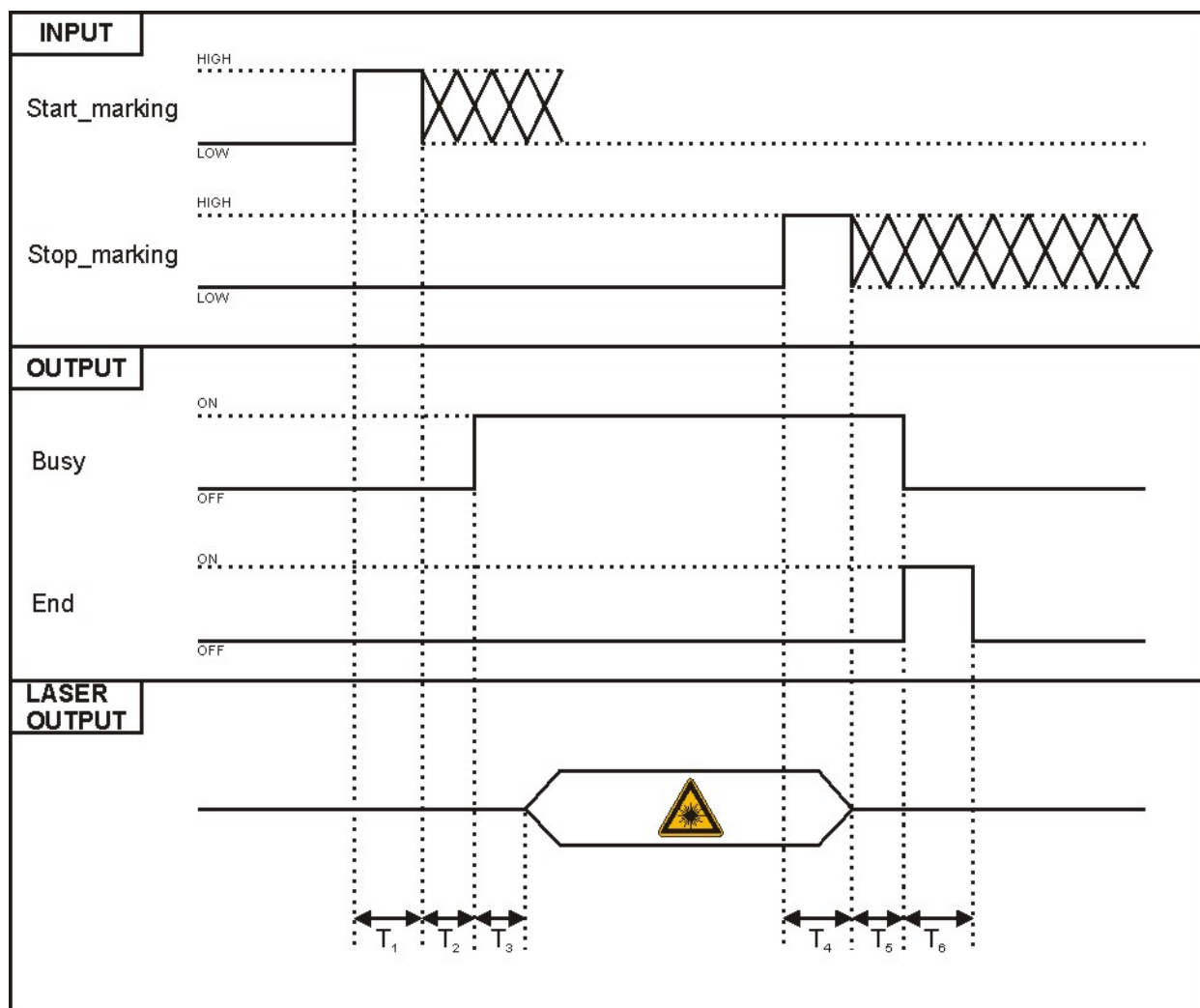

Figure 22: Timing signals

The time intervals in the diagram can all be programmed with a resolution of 1 ms (*).

T_1	Start Time	For setting the minimum acceptable time for the <i>START_MARKING</i> signal
T_2	Start Delay	For delaying the start of marking process
T_3	Busy Advance	<i>BUSY</i> signal corresponding to marking progress
T_4	Stop Time	The minimum time for <i>STOP_MARKING</i> signal to stop the marking process
T_5	Busy Delay	For delaying the Laser <i>END</i> signal with respect to laser emission
T_6	End Time	For setting the Laser End activation time

(*) Refer to Lighter user's manual "Setting I/O parameters" to set the signal's properties.

2.4.4 AXES CONNECTOR (I/O CONTROL)

Panel socket Sub-D, 25 positions, male.

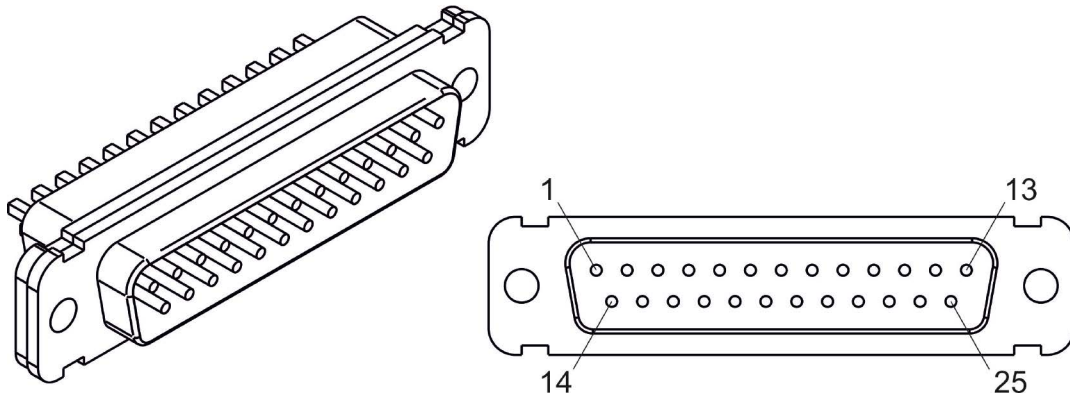

Figure 23: Male panel socket Sub-D 25 (front view).

PIN	SIGNAL	TYPE (**)	DESCRIPTION
1	EXT_12V	Output Power supply	Auxiliary 12V DC power supply available for drive input logical HIGH (max 250mA)
2	OUTPUT_0 (*) or STEP_Y	Digital Output	Generic output or Y-Axis drive step signal (Clock) for axis control
3	OUTPUT_2 (*) or STEP_Z	Digital Output	Generic output or Z-Axis drive step signal (Clock) for axis control
4	OUTPUT_4 (*) or BRAKE X	Digital Output	Generic output or X-Axis electromechanical brake release signal. ON during drive motion
5	OUTPUT_6 (*) or BRAKE Y	Digital Output	Generic output or Y-Axis electromechanical brake release signal. ON during drive motion
6	OUTPUT_8 (*) or BRAKE Z	Digital Output	Generic output or Z-Axis electromechanical brake release signal. ON during drive motion
7	INPUT_0 (*) or ZERO X	Digital Input	Generic input or X-Axis home sensor input. The home search is stopped when this signal goes HIGH
8	INPUT_1 (*) or ZERO Y	Digital Input	Generic input or Y-Axis home sensor input. The home search is stopped when this signal goes HIGH
9	INPUT_2 (*) or ZERO Z	Digital Input	Generic input or Z-Axis home sensor input. The home search is stopped when this signal goes HIGH
10	INPUT_3 (*) or DISABLE X	Digital Input	Generic input or X-Axis disable signal. When HIGH, the corresponding step signal remains in the status prior to activation
11	INPUT_4 (*) or DISABLE Y	Digital Input	Generic input or Y-Axis disable signal. When HIGH, the corresponding step signal remains in the status prior to activation
12	INPUT_5 (*) or DISABLE Z	Digital Input	Generic input or Z-Axis disable signal. When HIGH, the corresponding step signal remains in the status prior to activation
13	GND	Ground	Ground reference
14	OUTPUT_12 (*) or STEP R	Digital Output	Generic output or R-Axis drive step signal (Clock) for axis control

15	OUTPUT_1 (*) or STEP X	Digital Output	Generic output or X-Axis drive step signal (Clock) for axis control
16	OUTPUT_3 (*) or DIR Z	Digital Output	Generic output or Z-Axis drive direction signal
17	OUTPUT_5 (*) or DIR Y	Digital Output	Generic output or Y-Axis drive direction signal
18	OUTPUT_7 (*) or DIR X	Digital Output	Generic output or X-Axis drive direction signal
19	INPUT 9	Digital Input	Generic Input
20	INPUT 8	Digital Input	Generic Input
21	INPUT_7 (*) or ZERO R	Digital Input	Generic input or R-Axis home sensor input. The home search is stopped when this signal goes HIGH
22	INPUT_6 (*) or DISABLE R	Digital Input	Generic input or R-Axis disable signal. When HIGH, the corresponding step signal remains in the status prior to activation
23	OUTPUT_9 (*) or BRAKE R	Digital Output	Generic output or R-Axis electromechanical brake release signal. ON during drive motion
24	OUTPUT_11 (*) or DIR R	Digital Output	Generic output or R-Axis drive direction signal
25	GND	Ground	Ground reference

(*) enable an axis cause that the corresponding signals will no longer be available as generic inputs/output. Refers to Lighter user's manual, "Setting the X, Y, Z, and Rotor Axes parameters" to enable/disable Axes and set the Axes properties.

(**) see paragraph 2.5

2.4.5 RS232 CONNECTOR (COM2)

Panel socket Sub-D, 9 positions, male.

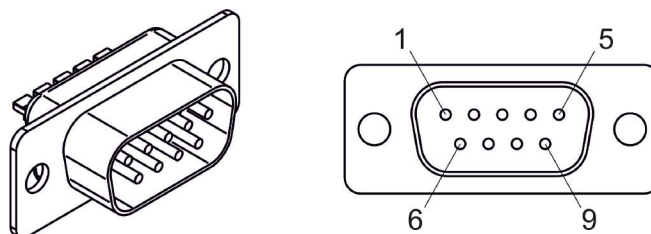

Figure 24: Male panel socket Sub-D 9 (front view).

PIN	SIGNAL	TYPE	DESCRIPTION
1	DCD	Input	Data Carrier Detect
2	RXD	Input	Receive Data
3	TXD	Output	Transmit Data
4	DTR	Output	Data Terminal Ready
5	GND	Ground	Ground reference
6	DSR	Input	Data Set Ready
7	RTS	Output	Request to Send
8	CTS	Input	Clear to Send
9	RI	Input	Ringing Indicator

2.4.6 ENCODER CONNECTOR

Panel socket BINDER, M12, 8 positions female, 763 series. Recommended encoder: Datalogic ENC58-S10-XXXX-M1 (ENC58-S10-5000-M12).

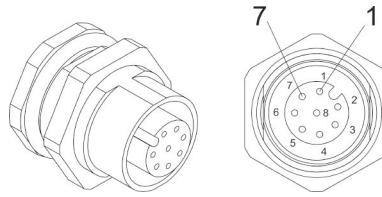

Figure 25: Female panel socket cod. 09-3482-87-08 (front view).

PIN	SIGNAL	TYPE	DESCRIPTION
1	GND	GND	Ground signal
2	VCC	POWER OUTPUT	12V DC power supply
3	ENC_A	DIGITAL INPUT	Encoder HTL A channel signal
4	GND	GND	Return signal for ENC_A
5	ENC_B	DIGITAL INPUT	Encoder HTL B channel signal
6	GND	GND	Return signal for ENC_B
7	NC	NC	NC
8	NC	NC	NC
BODY	SHIELD	SHIELD	SHIELD

2.4.7 PHOTOCELL CONNECTOR

Panel socket BINDER, M12, 4 positions female, 763 series. Recommended photocell: Datalogic S51-PA-5-B01-PK; Datalogic S15-PA-5-B01-PK or equivalent.

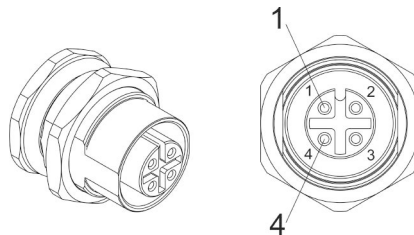

Figure 26: Female panel socket cod. 09-3482-87-04 (front view).

PIN	SIGNAL	TYPE	DESCRIPTION
1	VCC	POWER OUTPUT	12V DC power supply
2	NC	NC	NC
3	GND	GND	Ground signal
4	PHOTOCELL	DIGITAL INPUT	PNP photocell signal



WARNING!

For EMC compliance a RICHCO RRC-16-9-28-M2-K5B (or equivalent) must be used.

2.5 INPUT/OUTPUT SIGNAL SPECIFICATIONS

DIGITAL INPUT:

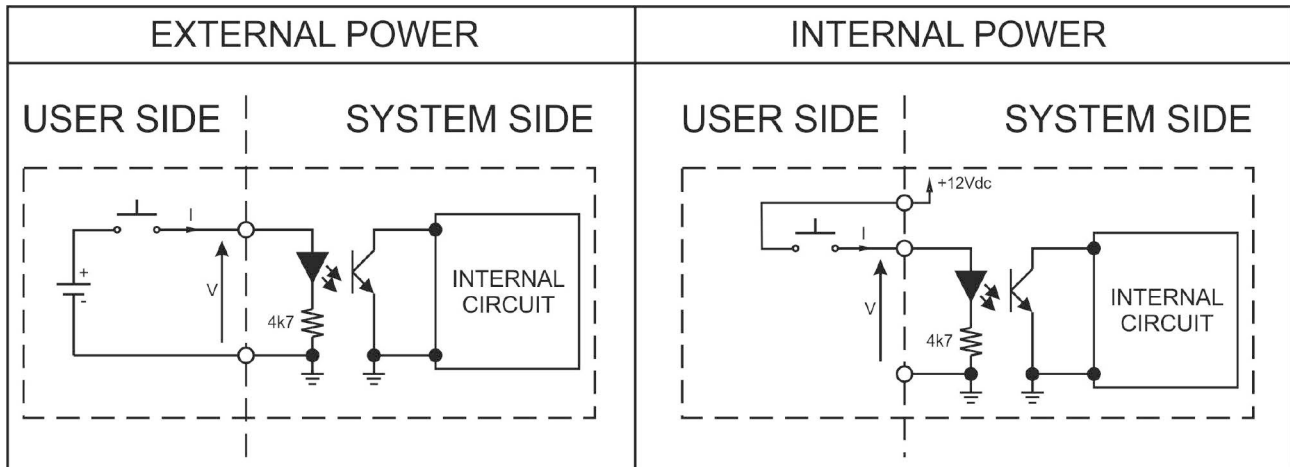

Type	Optocoupler		
V_{max}	24V DC		
I_{max}	5mA @ 24V DC		
Pulse Width	≥ 1 ms (debounce)		
	MIN	TYP	MAX
INPUT Logic LOW	0.0 V DC	0.0 V DC	2.0 V DC
INPUT Logic HIGH	5.0 V DC	12.0 V DC	24.0 V DC

DIGITAL OUTPUT:

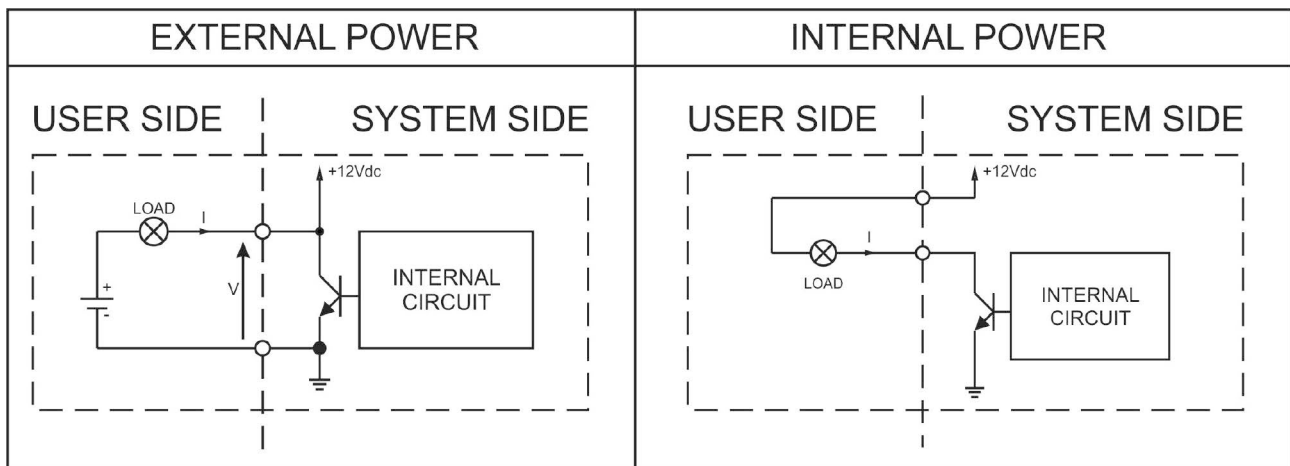

Type	Low side driver
V_{max}	24V DC
I_{max}	250mA
$V_{saturation}$	< 0.5 V DC
Leakage current	< 5 μ A
OUTPUT State ON	$V \leq 0.5$ V DC; $I \leq 250$ mA
OUTPUT State OFF	$V \leq 24$ V DC; $I \leq 5$ μ A

2.6 CONNECTION EXAMPLES

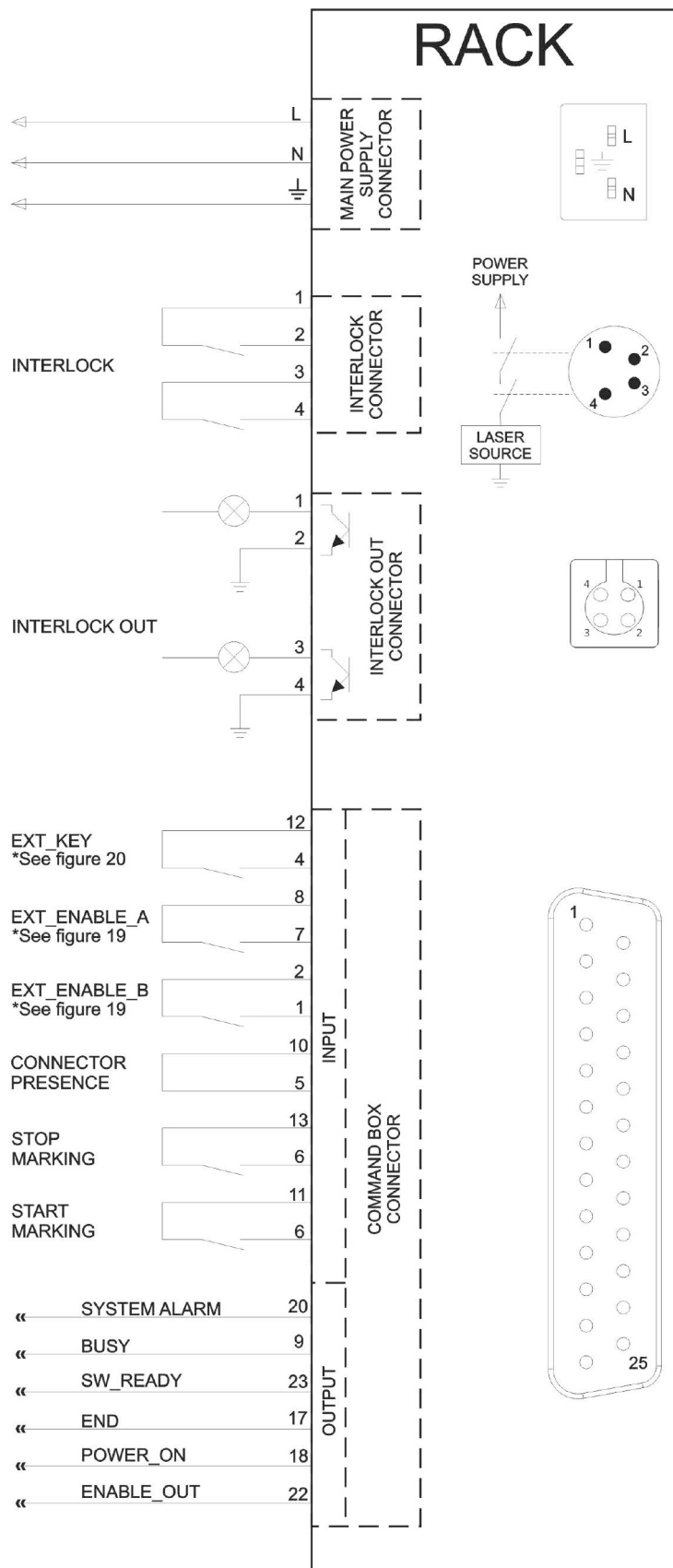

Figure 27: Connection examples.

3 INSTALLATION AND SET UP

3.1 CONNECTIONS

This section of the manual describes the marking system wiring. Carry out the connecting operations as described below.



WARNING!

Connect the marking system to others **WITHOUT** voltage in order to avoid risks for the operator and for the marking system.

3.1.1 CONNECTING COMMAND BOX CABLE

Connecting Command Box cable.

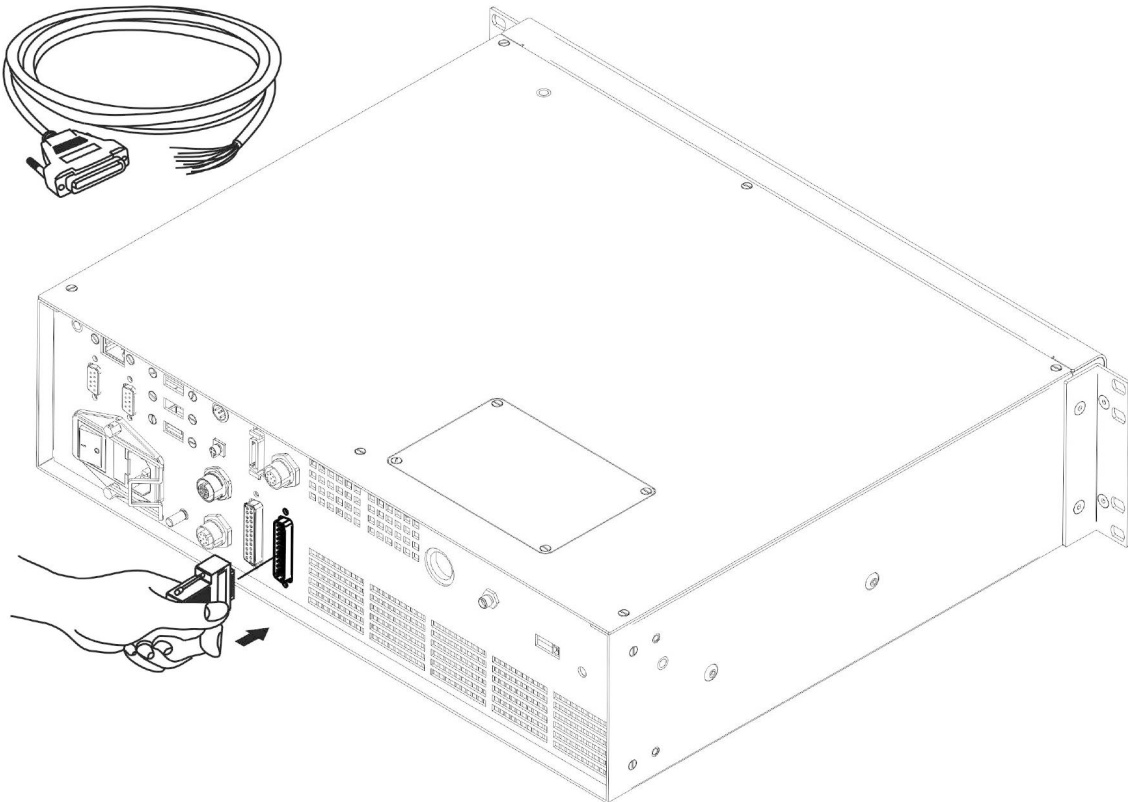

Figure 28: Connecting Command Box cable.



NOTE:

The Command Box cable must always be inserted in order to use Enable and Key on the front panel of the rack.

3.1.2 CONNECTING INTERLOCK CABLE

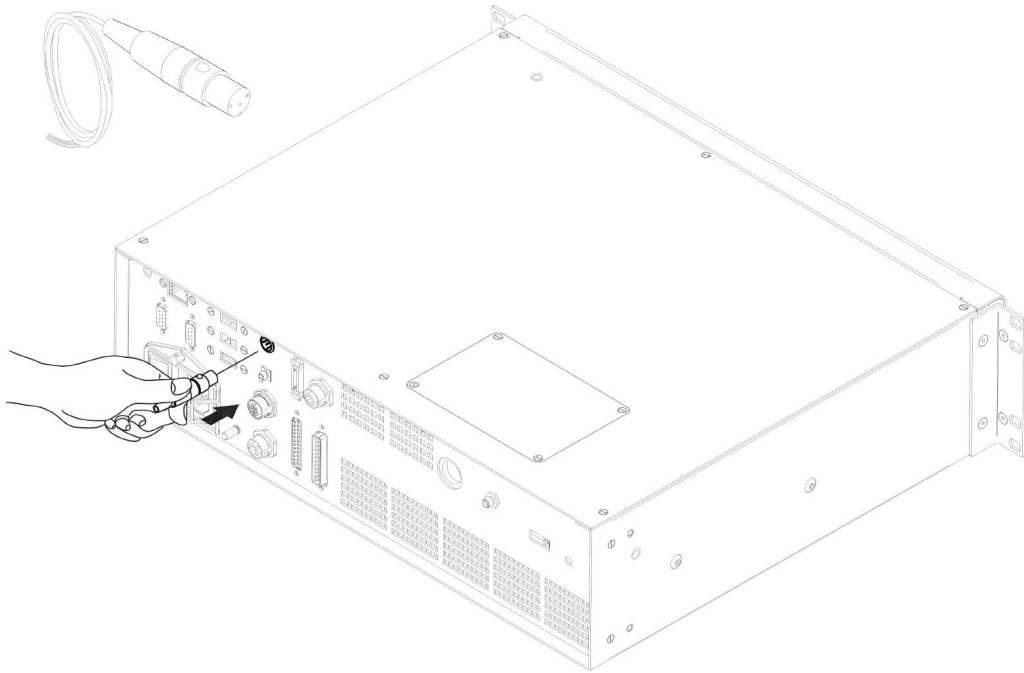

Figure 29: Connecting interlock cable.



NOTE:

The interlock cable must always be inserted in order to use the marking system. The absence of such connector locks the system.

3.1.3 CONNECTING INTERLOCK OUT CONNECTOR

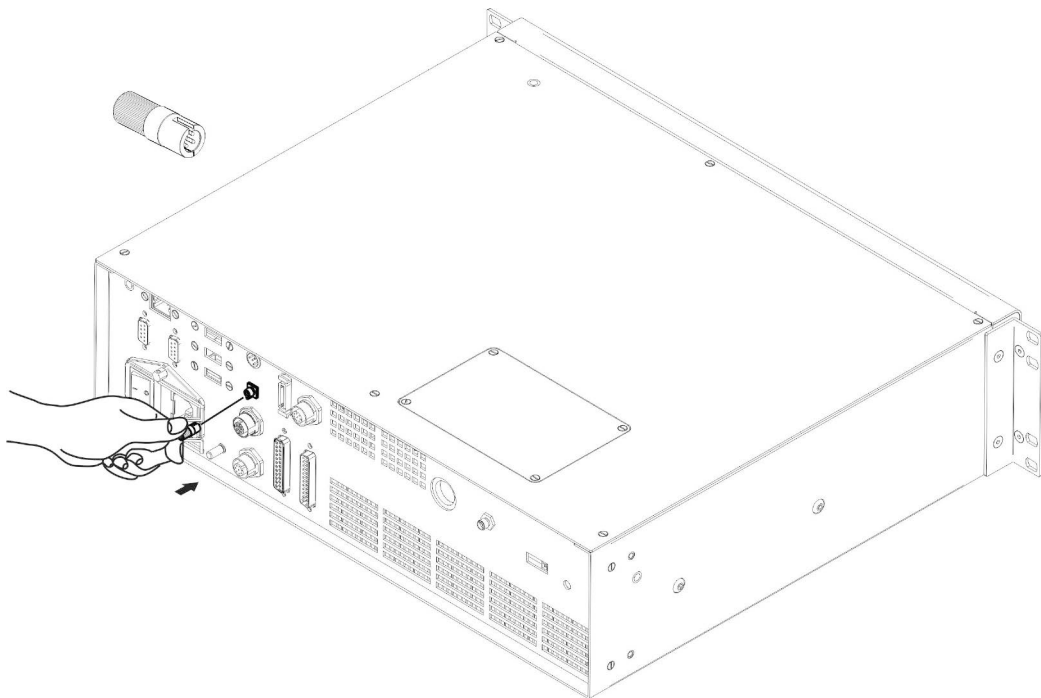

Figure 30: Connecting interlock OUT connector.

3.1.4 CONNECTING THE OPTICAL FIBER TO THE CONTROL RACK

Follow the steps listed here below to connect the optical fiber to the control rack:

- 1) unscrew the four screws holding the cover plate on the rack.

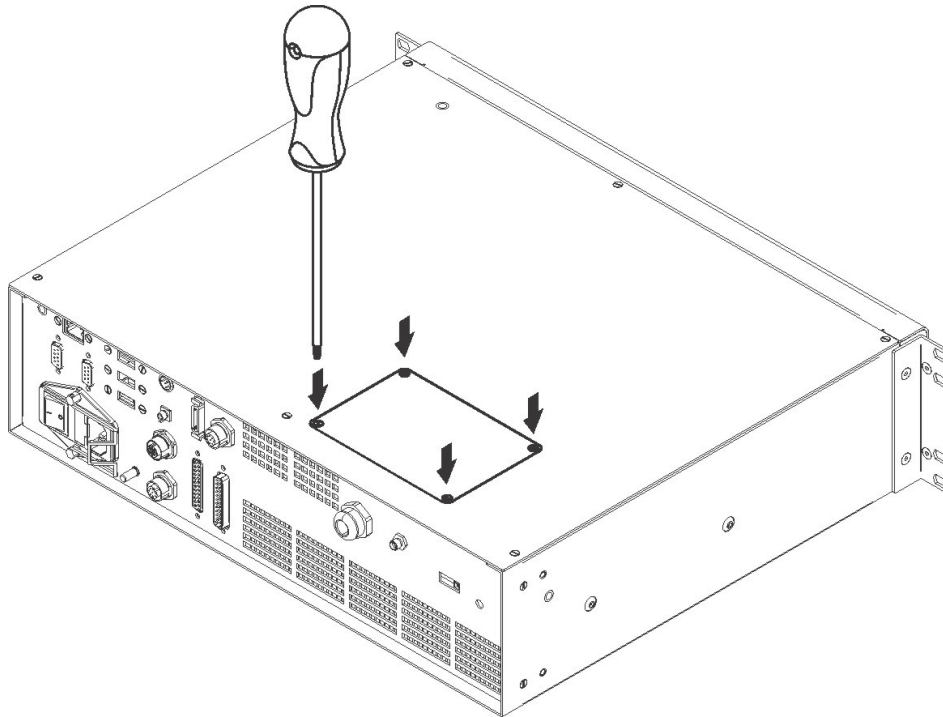

Figure 31: Removing the cover plate from the rack.

- 2) insert the optical fiber into the cable gland without removing its protection cap.



WARNING!

The insertion of the optical fiber is a delicate operation. You must make sure that the optical fiber is protected by his cap during insertion in the antenna cable to avoid damage or dirty it.

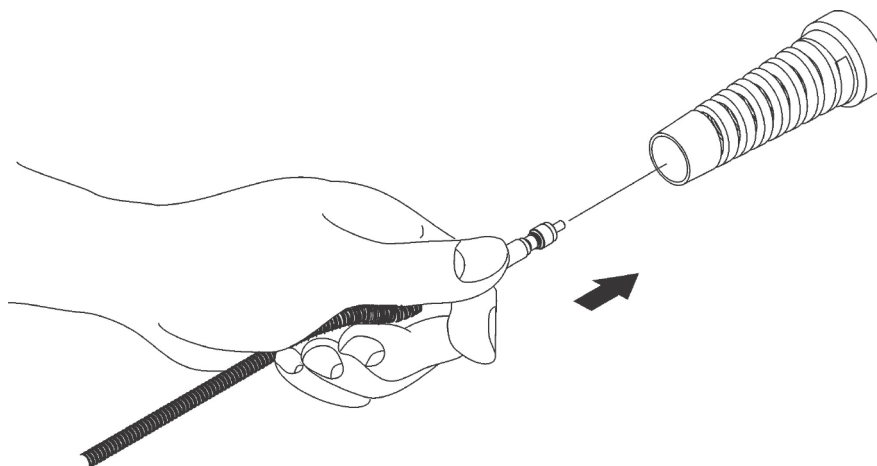

Figure 32: Passing the optical fiber through the cable gland.

3) insert the optical fiber into the PG cable gland mounted on the rear panel of the rack.

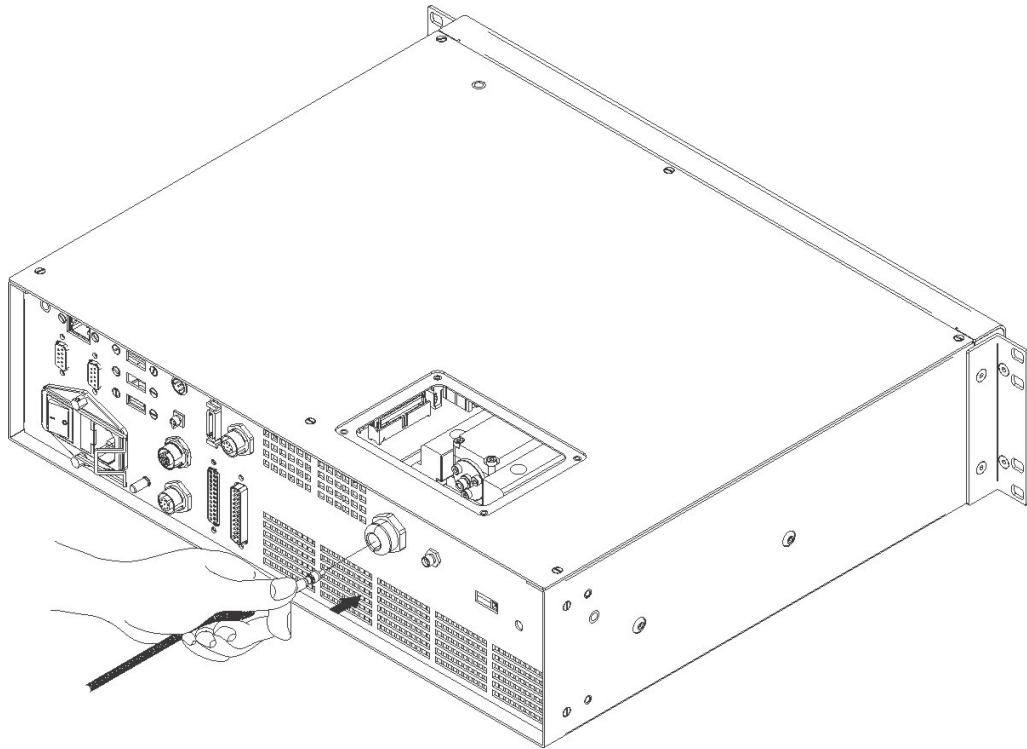

Figure 33: Passing the optical fiber through the PG cable gland.

4) remove the drain plug and tighten to form the fiber diode paying attention not to soil or scratch the fiber end.

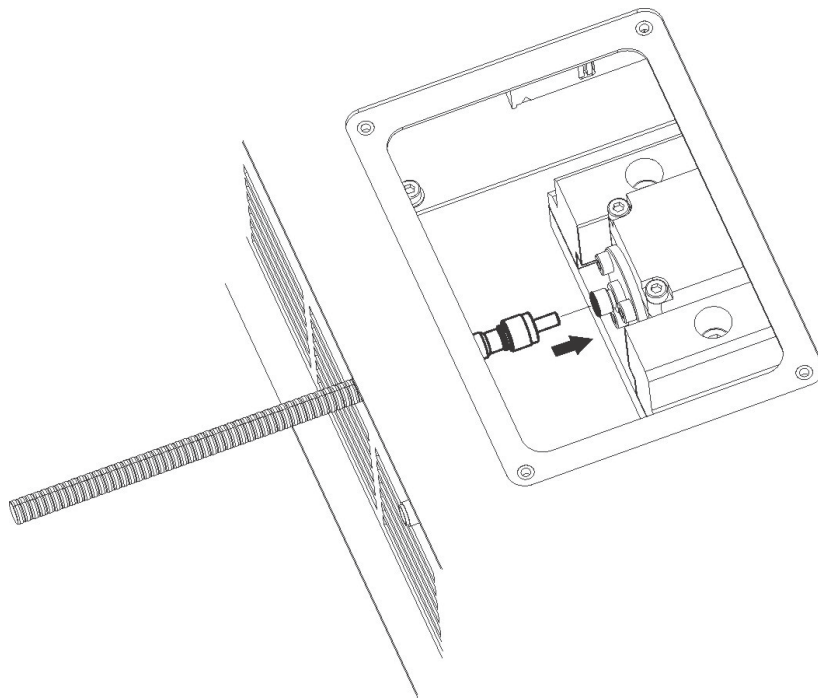

Figure 34: Connection of the optical fiber.

5) fixing the cable gland on the PG.

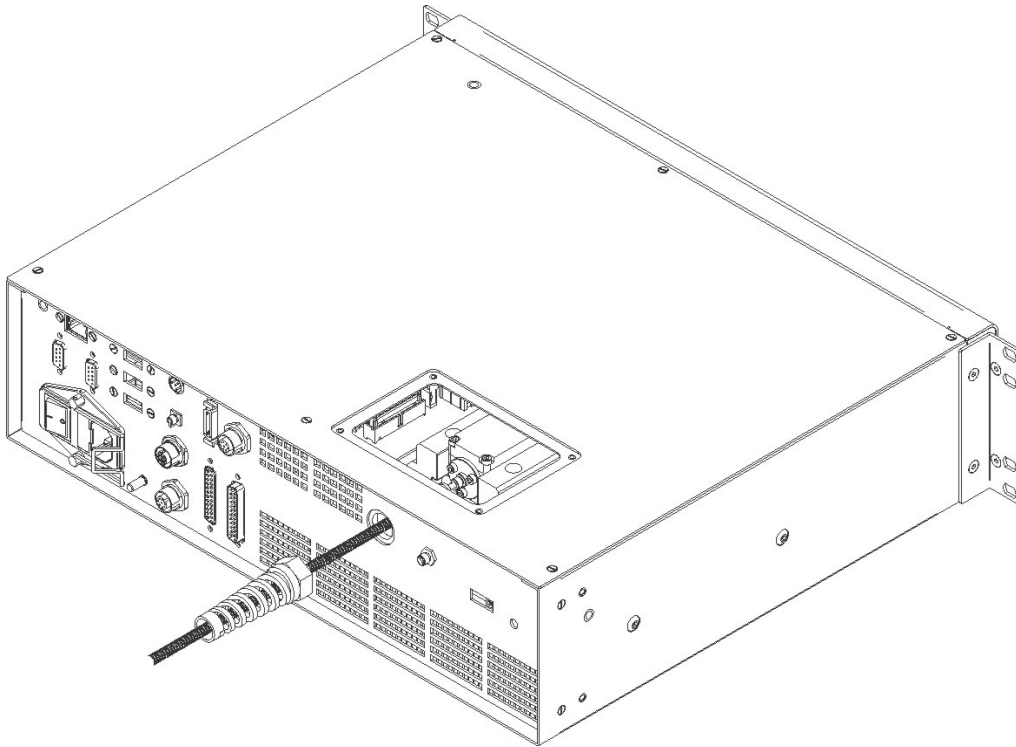

Figure 35: Fixing the cable gland.

6) closing rack top cover.

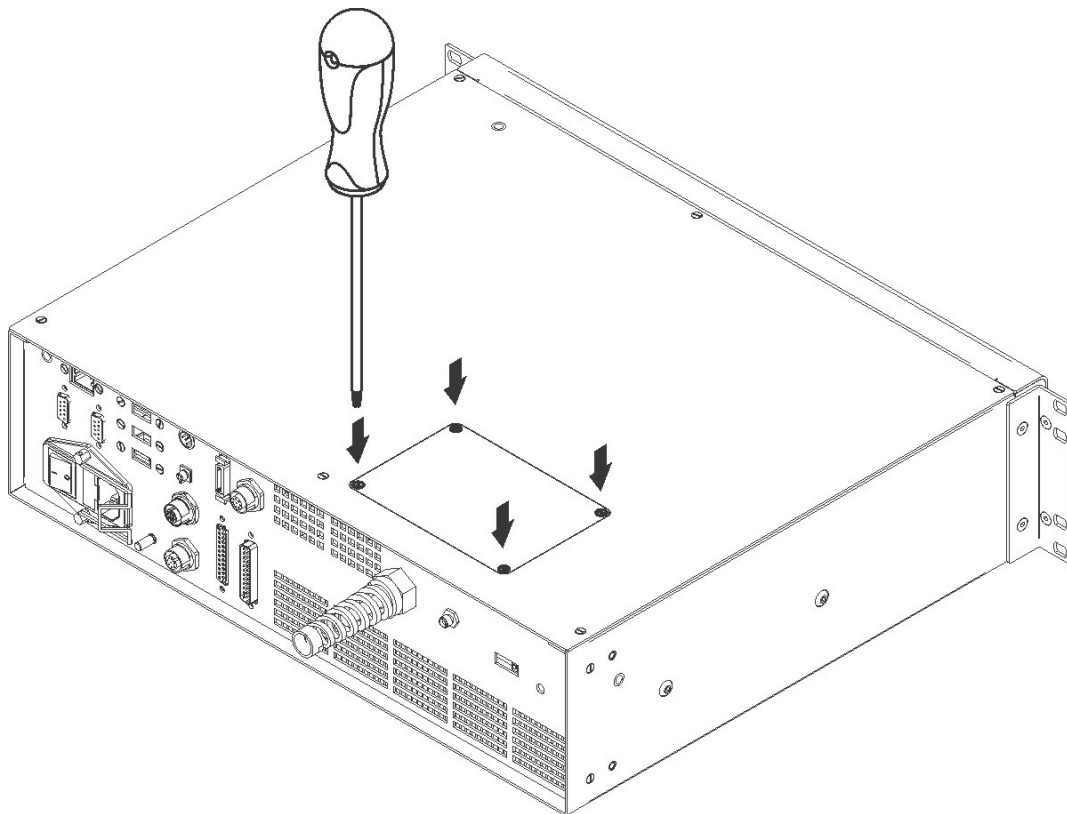

Figure 36: Closing cover.

3.1.5 CONNECTING THE OPTICAL FIBER ON THE RESONATOR

Follow the steps listed here below to wire the optical fiber to the resonator:

- 1) unscrew the three screws that secure the metallic cover and cable gland to the resonator.

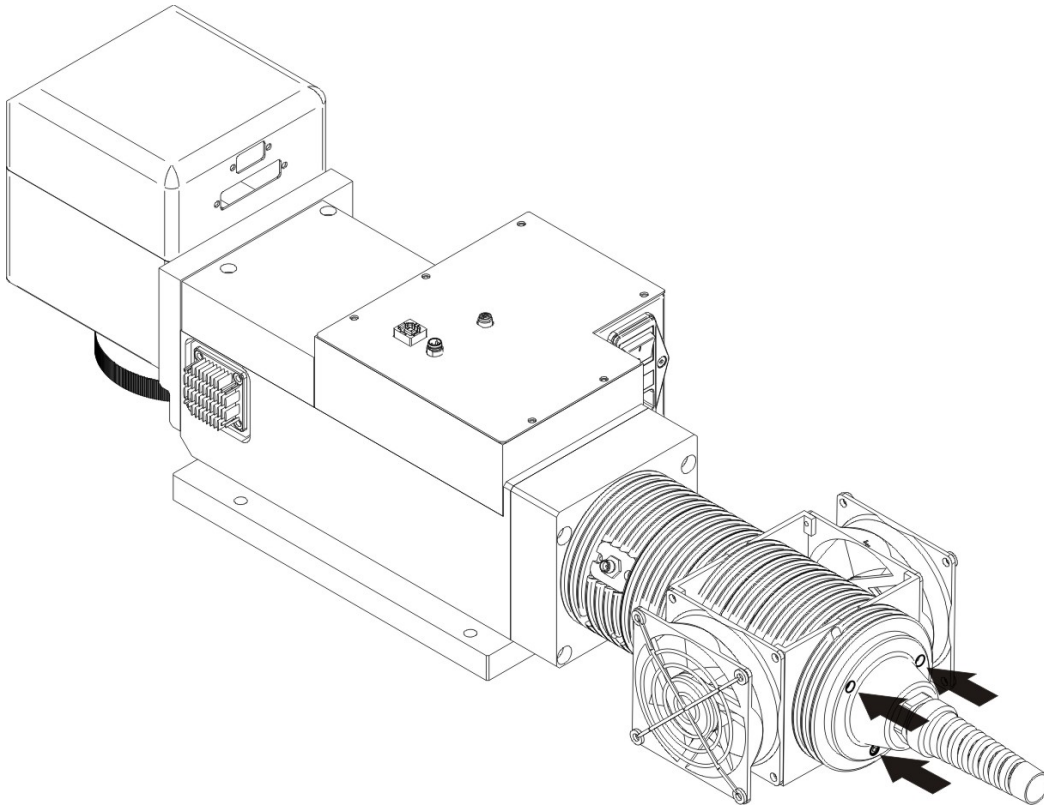

Figure 37: Disassembling the optical fiber cable gland from the resonator.

- 2) insert the optical fiber in the cable gland without removing the **protection cap**.



WARNING!

The insertion of the optical fiber is a delicate operation. You must make sure that the optical fiber is protected by his cap during insertion in the antenna cable to avoid damage or dirty it.

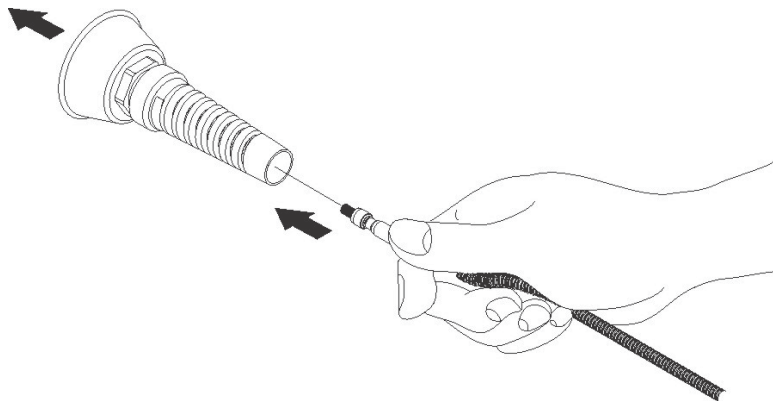

Figure 38: Passing the optical fiber through the cable gland.

- 3) remove the protection cap and insert the optical fiber in the resonator, being careful not to damage the end of the fiber or getting it dirty.

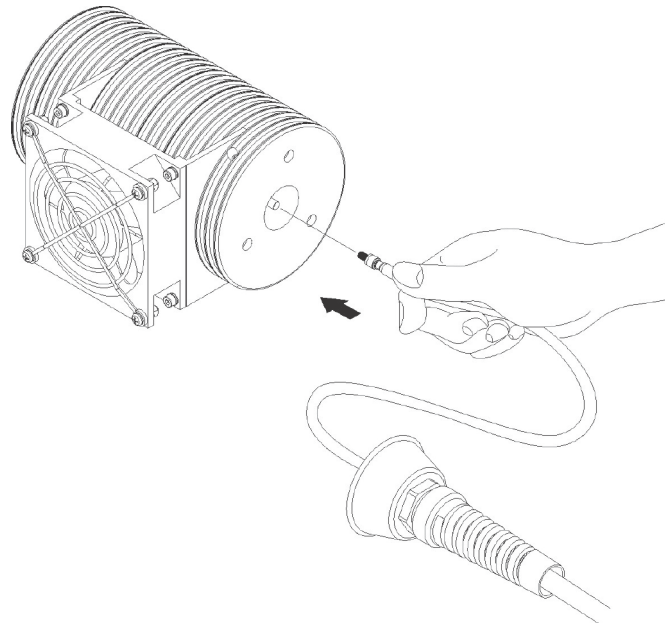

Figure 39: Connecting the optical fiber to resonator.

- 4) screw the protection cap back on the resonator.

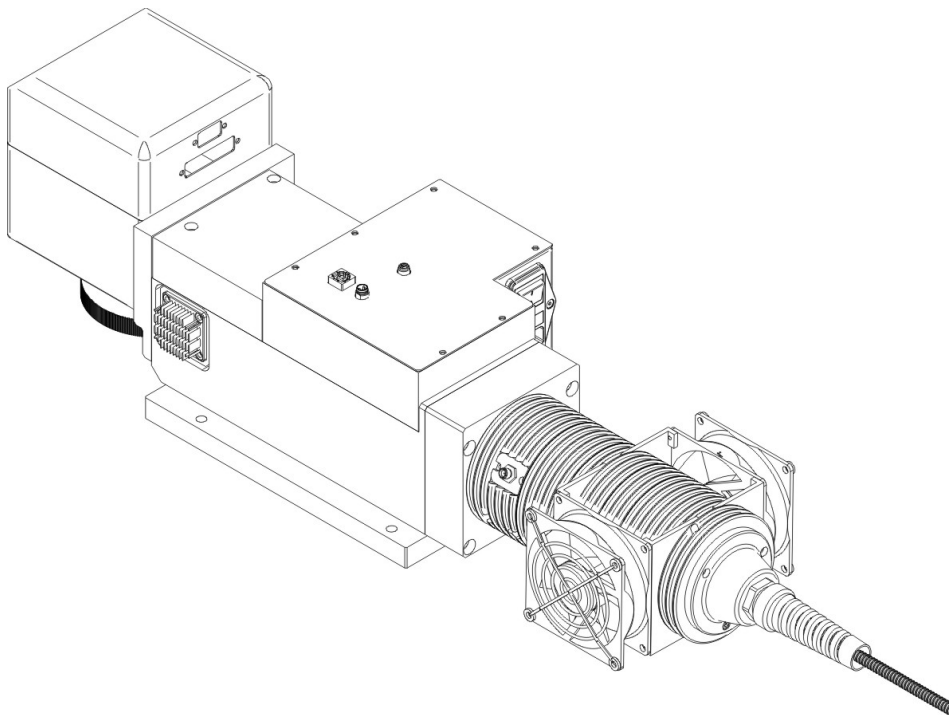

Figure 40: Final closing.



WARNING!

To avoid damaging or breaking the optical fiber, never subject it to rays with a curve under **20 cm**.

3.1.6 CONNECTING RADIOFREQUENCY CABLE

Screw in SMA connectors, starting at resonator side (90° end) then at the rack side.

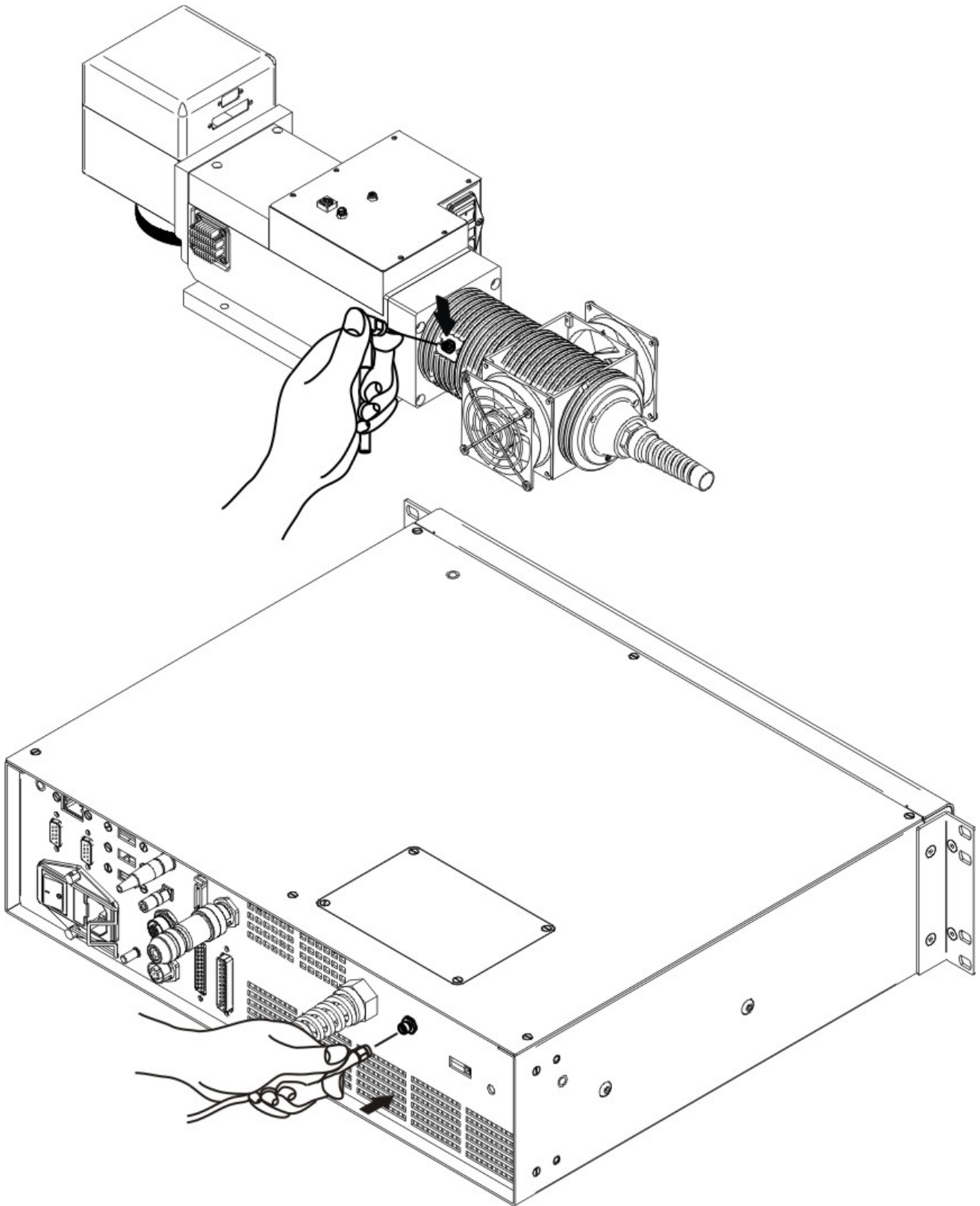

Figure 41: RF cable connection.

3.1.7 CONNECTING MDR CABLE

Connecting MDR cable to rack:

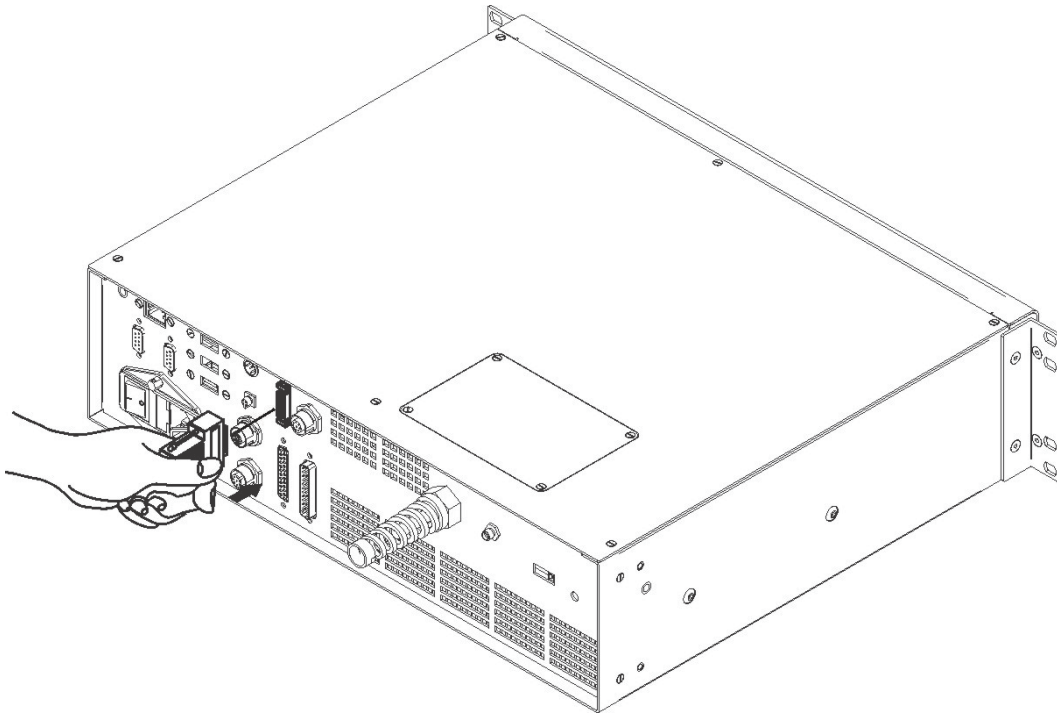

Figure 42: MDR connection side rack.

Connect the other end of the cable to the scanner head.

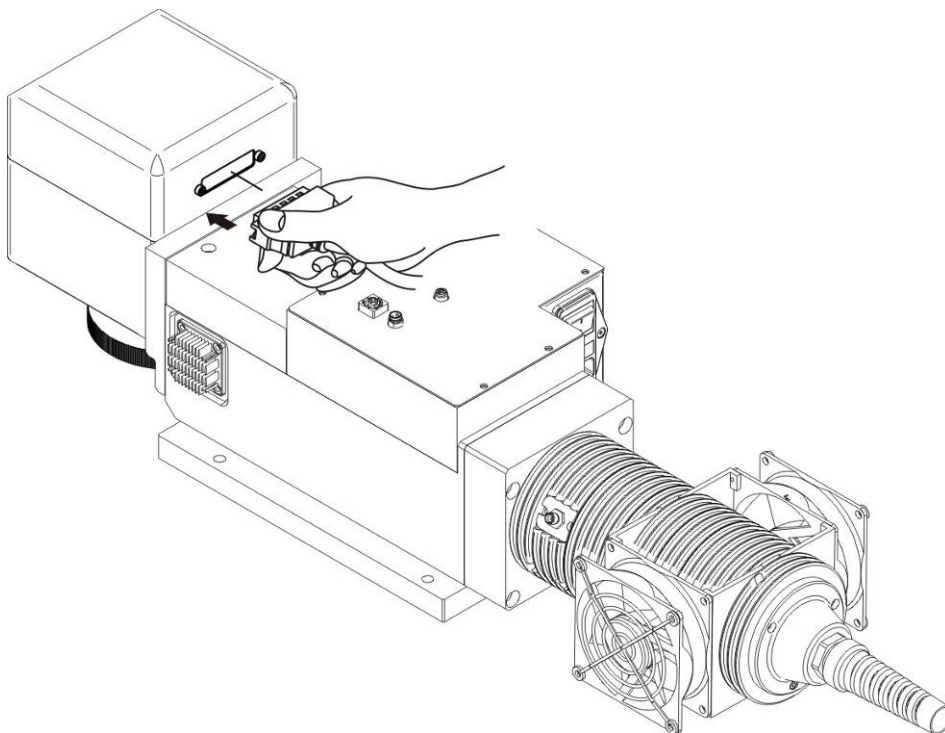

Figure 43: MDR connection side resonator.

3.1.8 CONNECTING RESONATOR CABLE

Connecting resonator cable to rack:

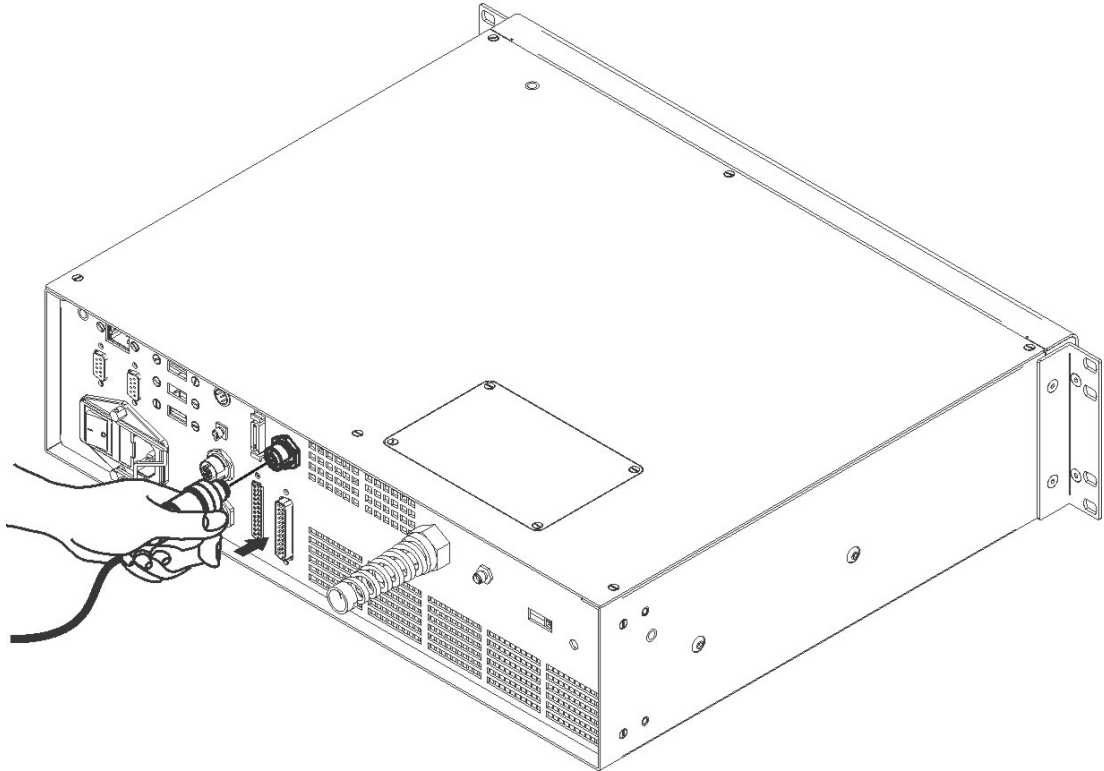

Figure 44: Resonator cable connection side rack.

Connect the other end of the cable to the resonator.

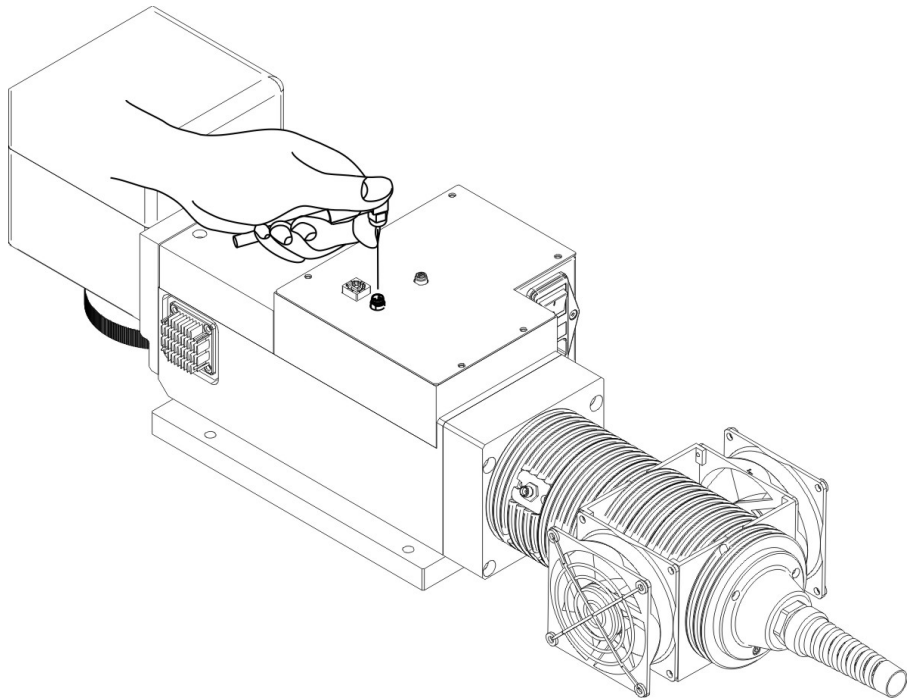

Figure 45: Resonator cable connection side resonator.

3.1.9 CONNECTING FAN CABLE

Connect fan cable to resonator.

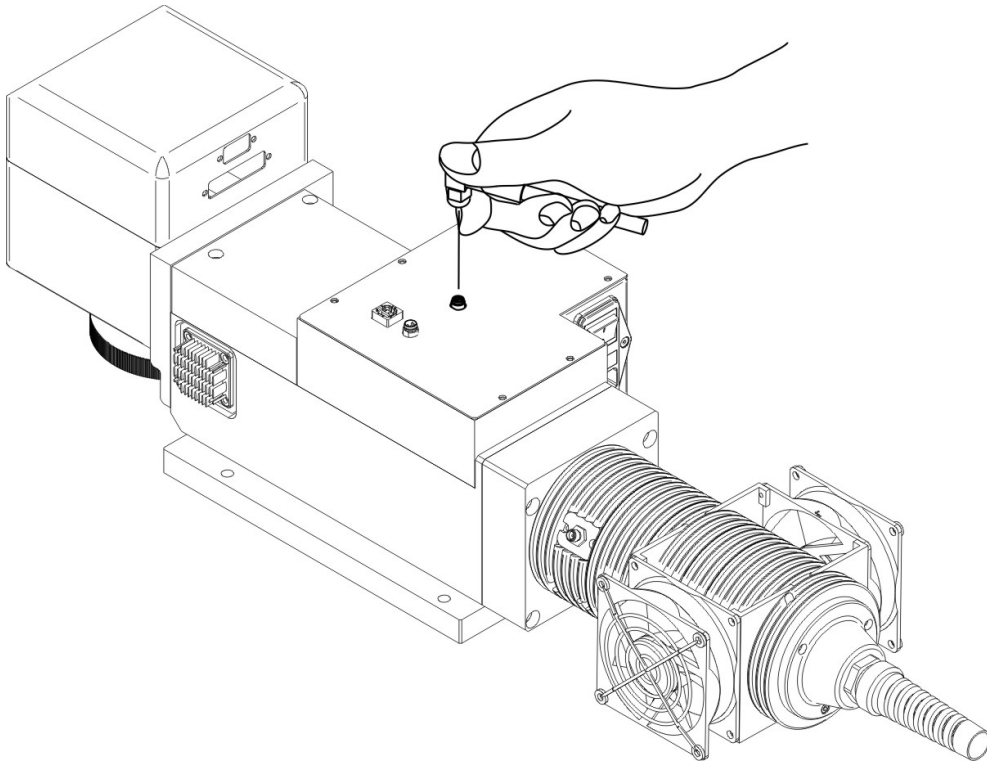

Figure 46: Resonator fan cable connection.

3.1.10 CONNECTING POWER SUPPLY CABLE

Connecting power supply cable.

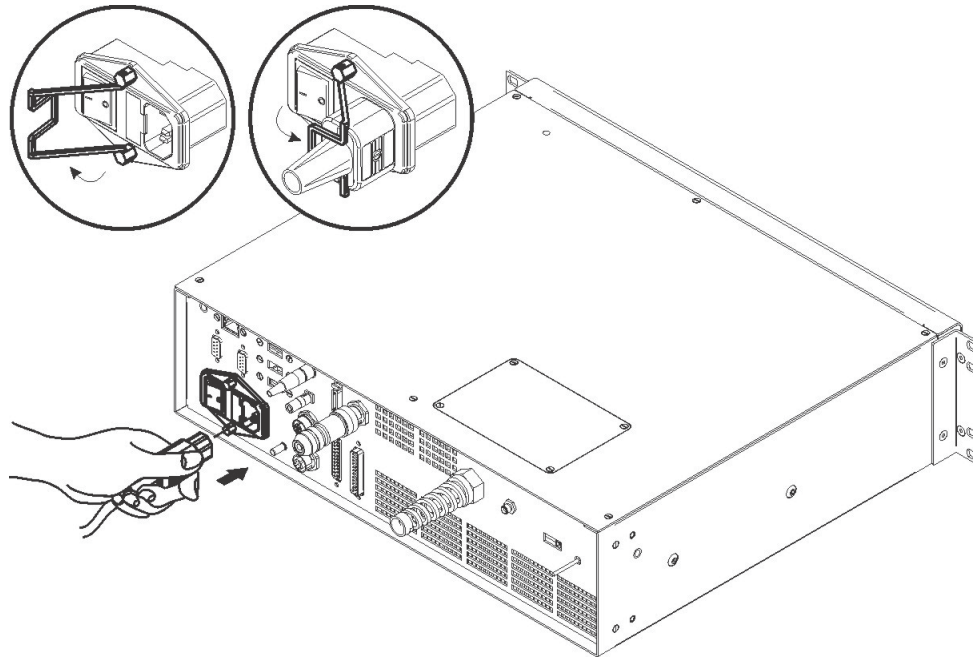

Figure 47: Power supply cable connection.



NOTE:

Lock the plug with the retaining clamp to avoid accidental disconnection.

3.1.11 GROUND CONNECTION

To ensure high electrical noise immunity it is strongly recommended to connect the chassis to earth plant.

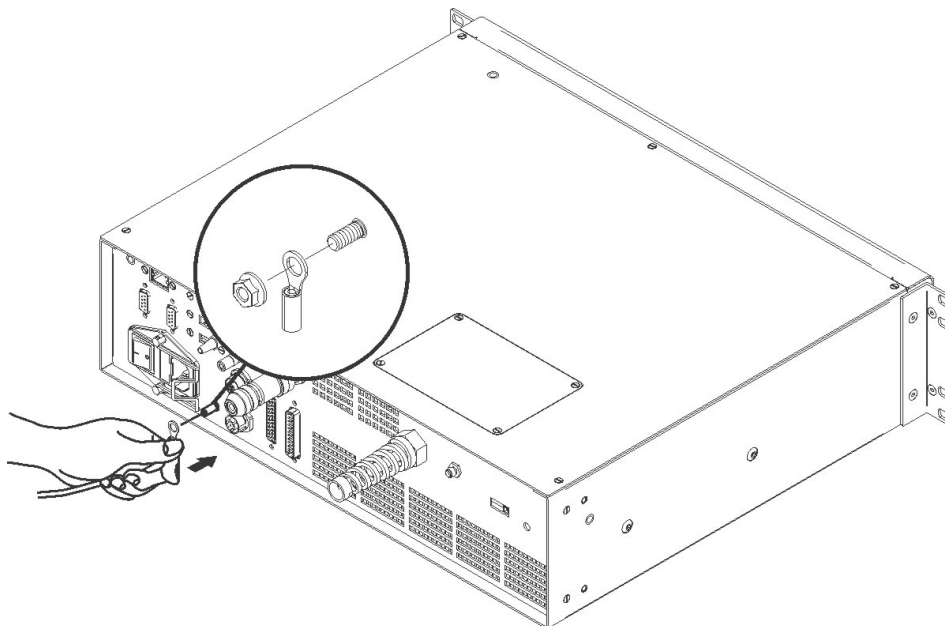

Figure 48: Ground connection.

3.1.12 CONNECTING RESONATOR POWER SUPPLY CABLE

Connection the AC power supply to the resonator.

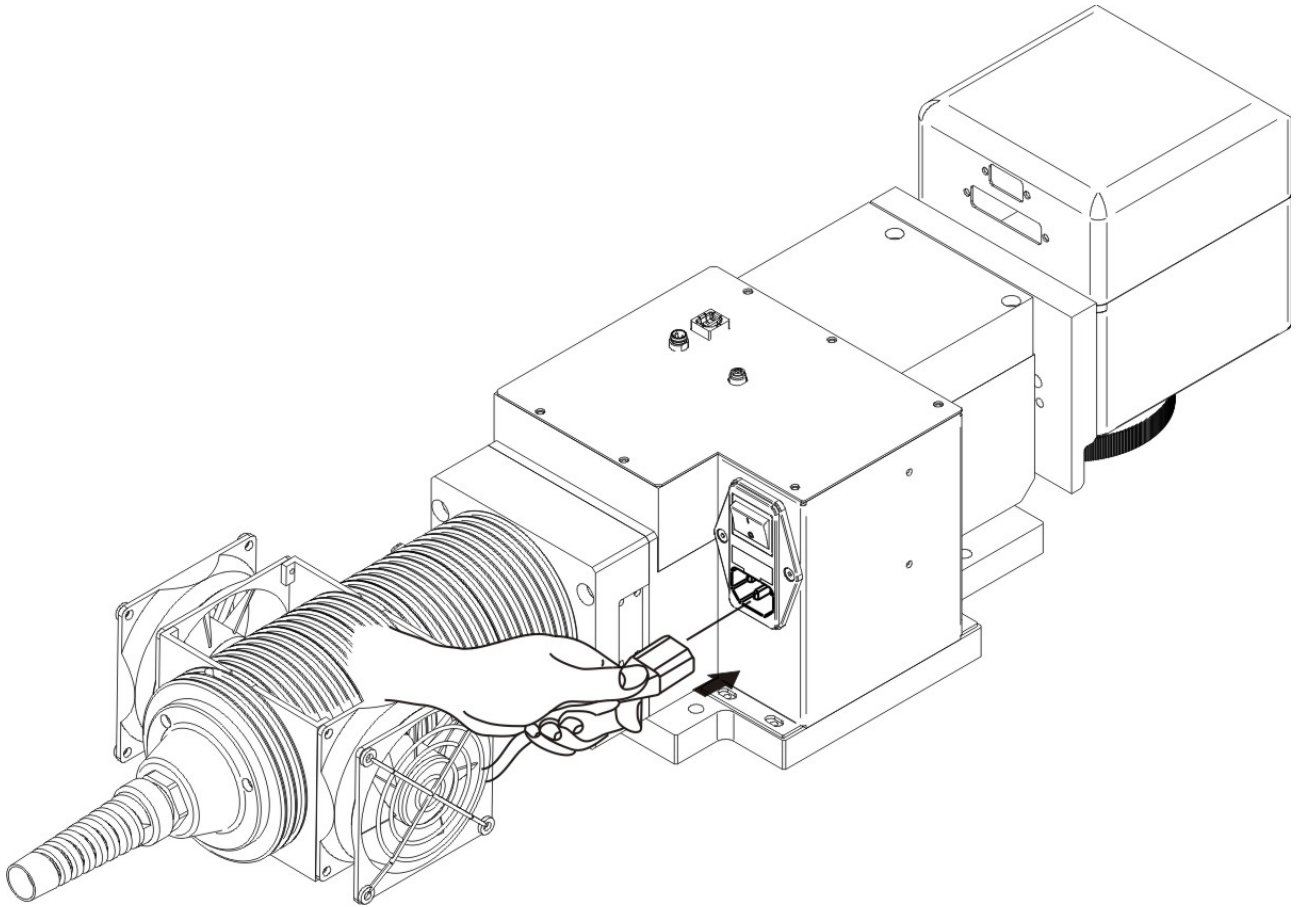

Figure 49: Connection the power supply.

3.1.13 LOCAL MODE CONNECTION

To use the marking system in “Local Control” mode it is necessary to install a mouse, keyboard and monitor to the system. Connect the monitor and input devices as shown below:

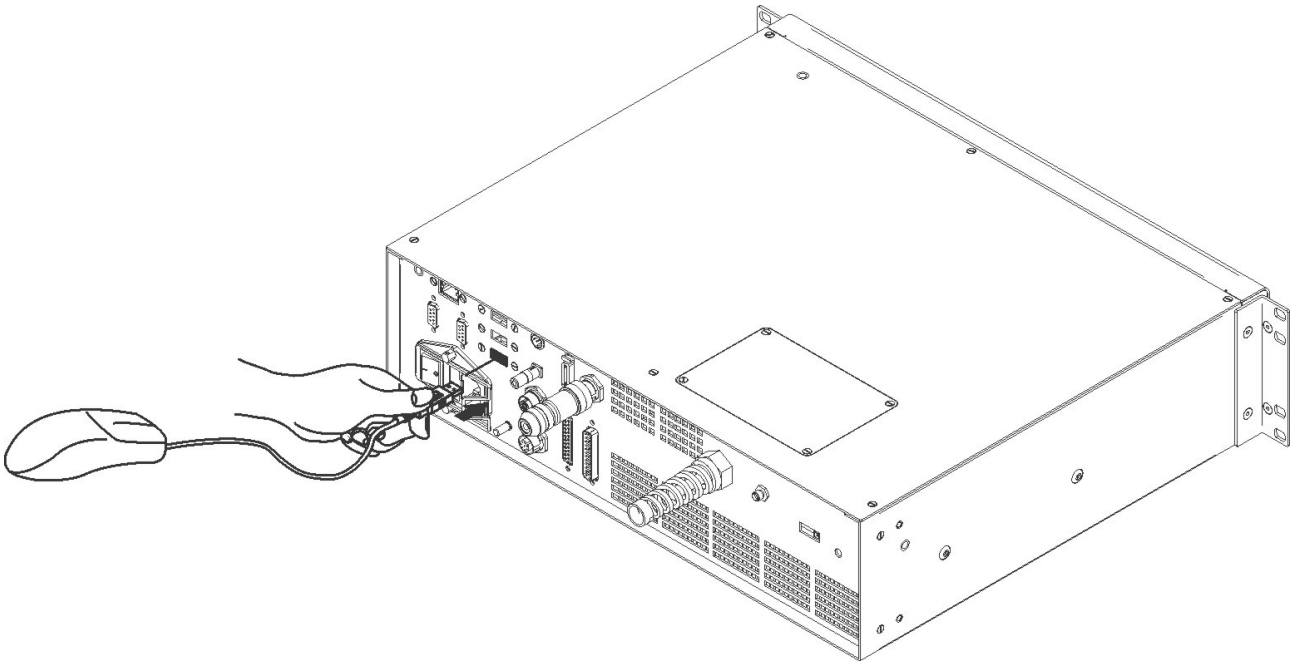

Figure 50: USB mouse connection.

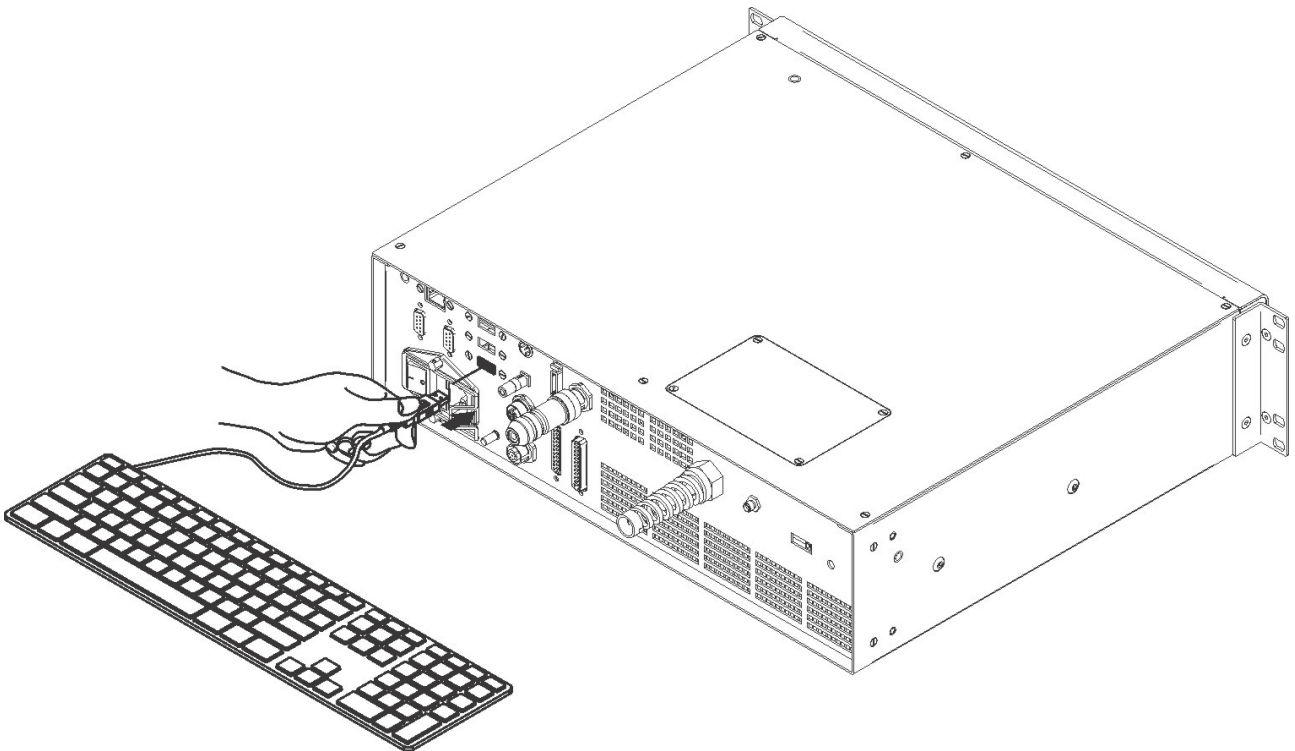

Figure 51: USB keyboard connection.

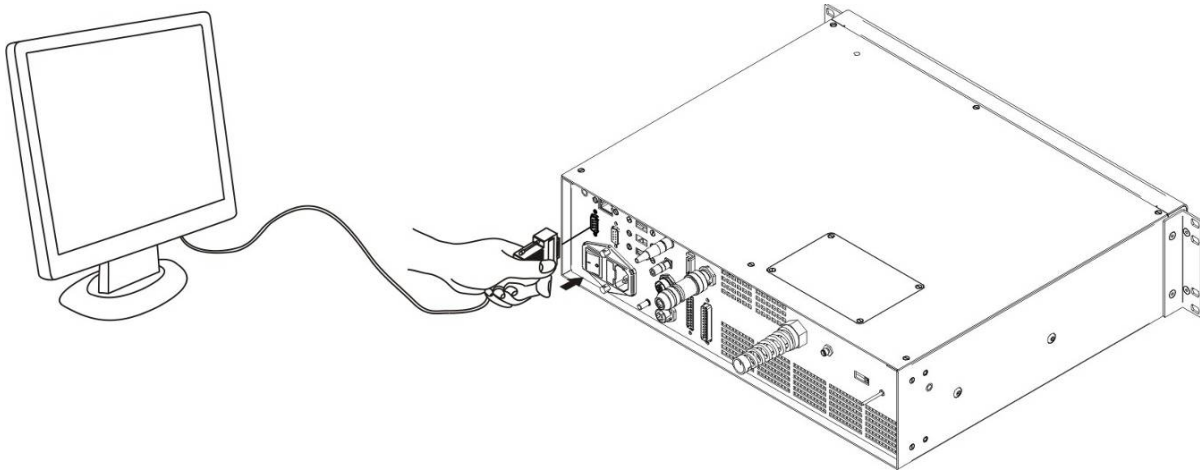

Figure 52: VGA monitor connection.



NOTE:

Minimum resolution 800 x 600.

3.1.14 REMOTE MODE CONNECTION

To use the marking system in “Remote Mode” it is necessary to connect a network cable:

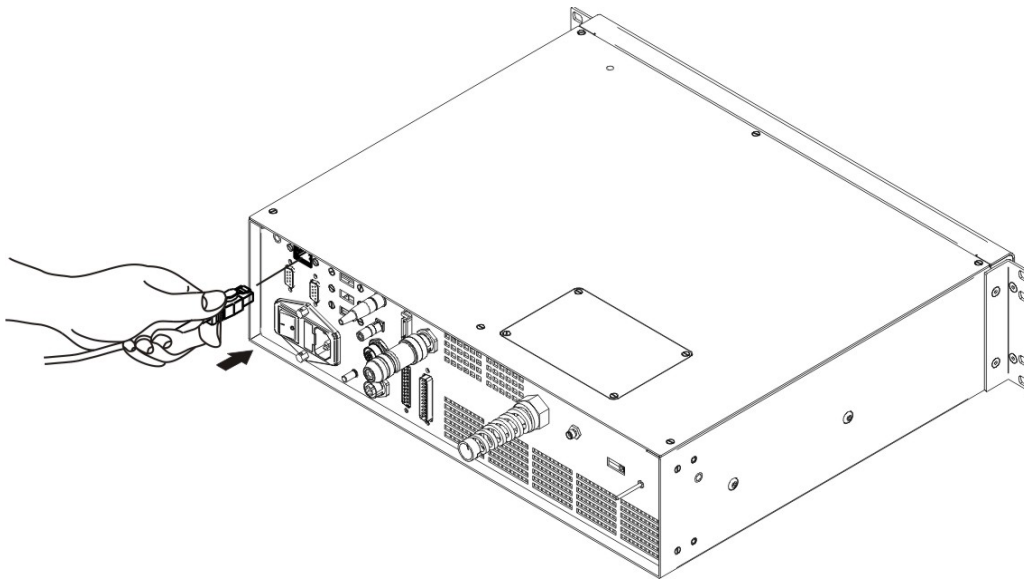

Figure 53: RJ45 Ethernet connection.



NOTE:

The system LAN is configured by default with a fixed IP Address and Subnet Mask:

- Default IP address: 192.168.0.10

- Default Subnet Mask: 255.255.255.0

See chapter 5.2 in order to change LAN configuration.



NOTE:

Ethernet TCP/IP 10, 100 Mbit.

3.1.15 F-THETA LENS PROTECTION CAP REMOVAL

Remove the F-Theta Lens protection cap before marking operation.

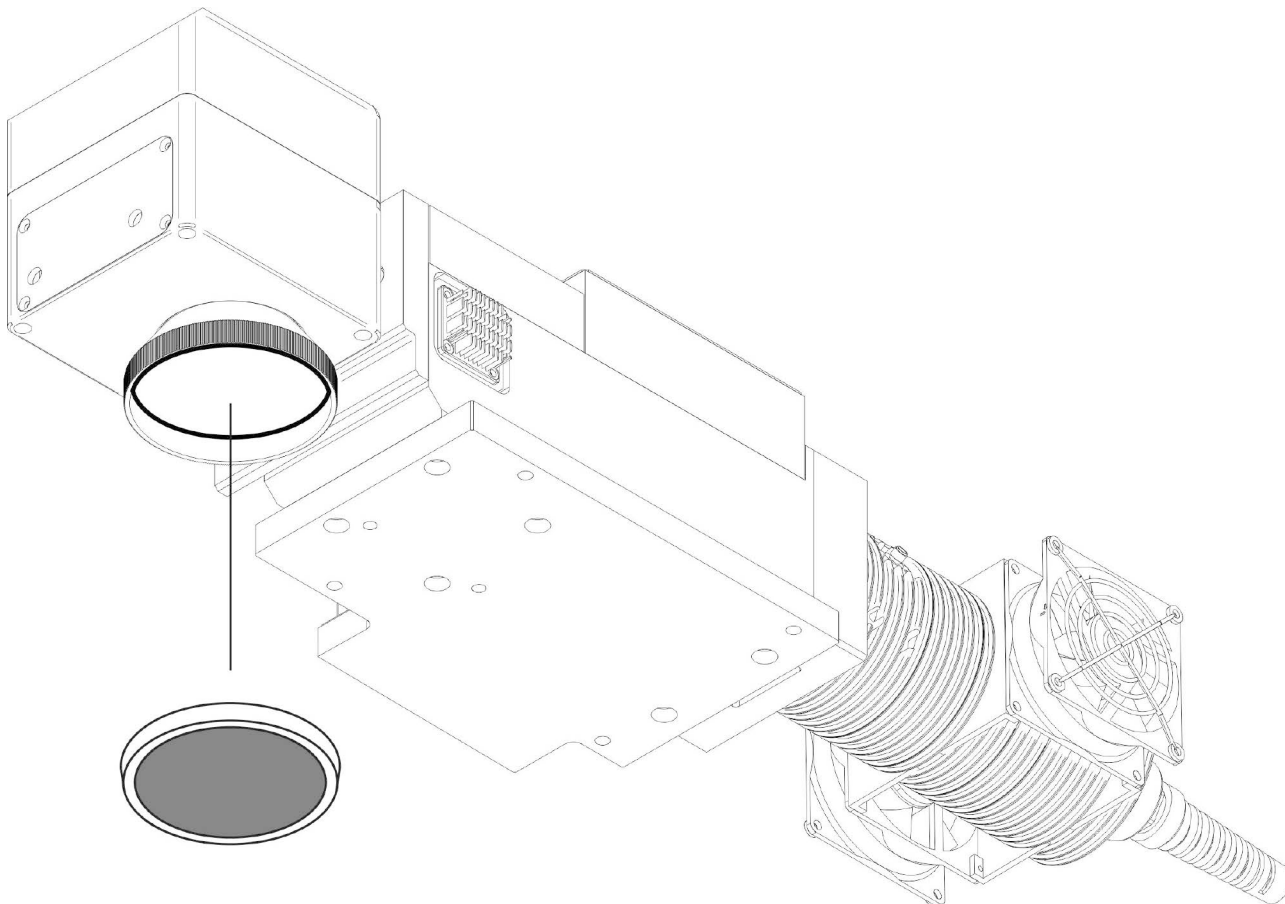

Figure 54: F-Theta Lens protection cap removal.



WARNING!

Marking with the lens protection cap could result in damage to the lens.

4 USE AND OPERATION

4.1 TURNING ON SEQUENCE

1ST: before turning on the marking system, be sure that the system is connected as previously described. Check presence of voltage power supply connection, interlock connector and Command Box connector. Check that Key and Enable commands on the rack front panel are disabled (see Figure 19 and Figure 20).

1ST: turn on the switch on resonator. Wait about 20 minutes before proceeding to the next step. This waiting time is necessary for the correct warm-up and performance stabilization of the resonator:

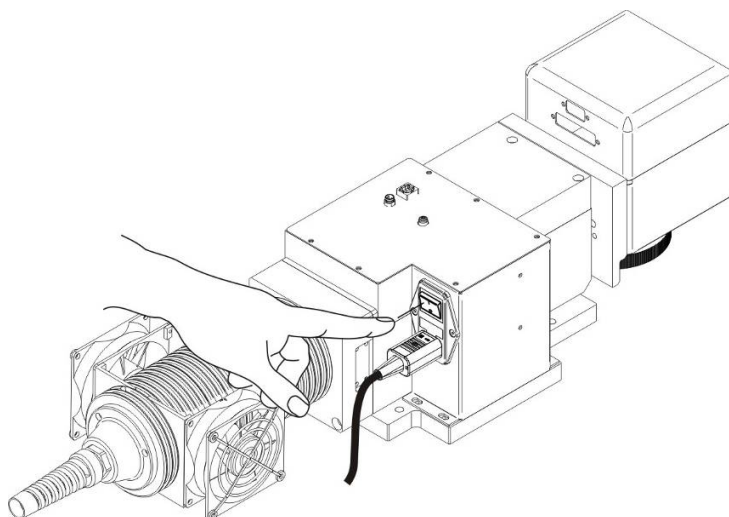

Figure 55: Power on resonator.



NOTE:

The warm up time is about 20 minutes with 220V AC power supply. For lower voltage (ie: 110V AC) one should expect a longer wait time.

2ND: turn on the main switch in the back of the control rack:

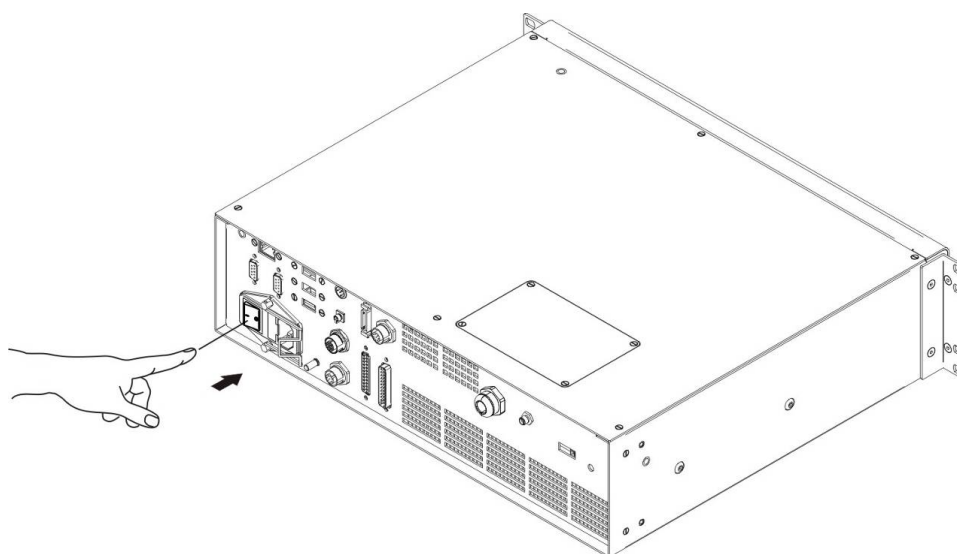

Figure 56: Power on control rack.

During booting-up, status LED on the rack front panel will be blinking green.

Wait the end of the booting-up. The status LED on the rack will be steady green.

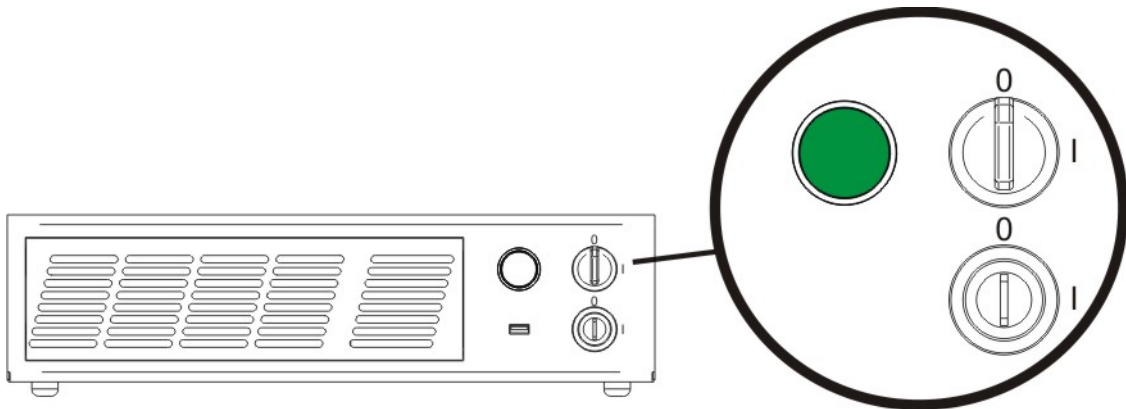

Figure 57: Status LED display.

3RD: activate the command key, by rotating it clockwise:

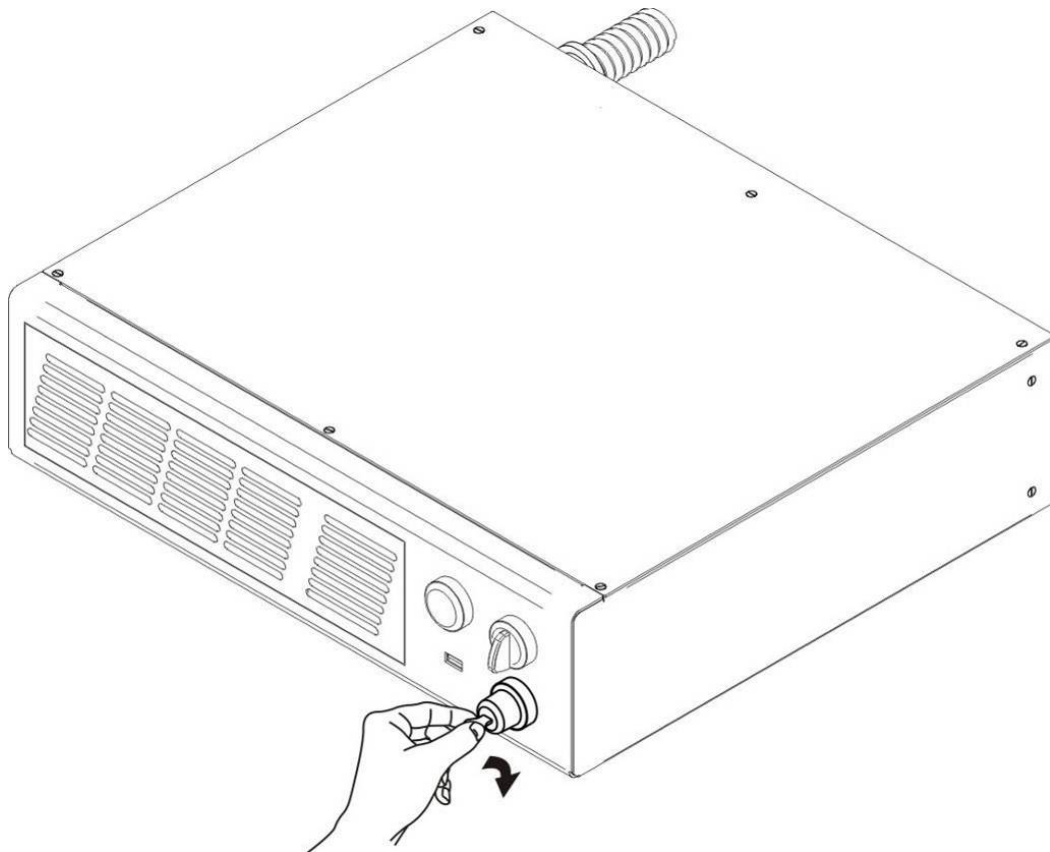

Figure 58: Enable signal KEY.

When the *KEY* signal is enabled, the status LED on the rack will be blinking orange for about 20 seconds (laser source warm-up).

Wait the end of the laser source warm-up. The status LED on the rack and the LED bar on the Scan Head will be steady orange.

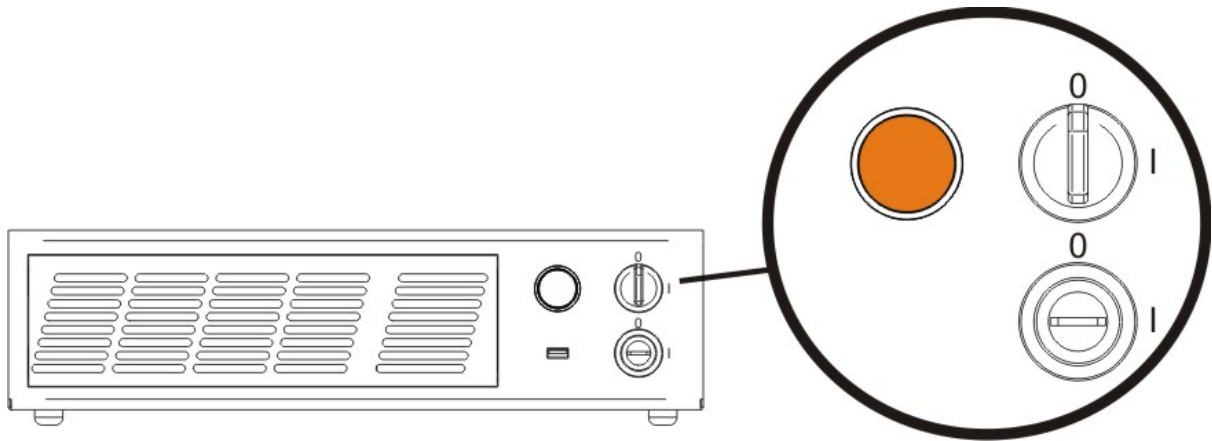

Figure 59: Status LED display.

4TH: activate the *ENABLE* command by rotating it clockwise:

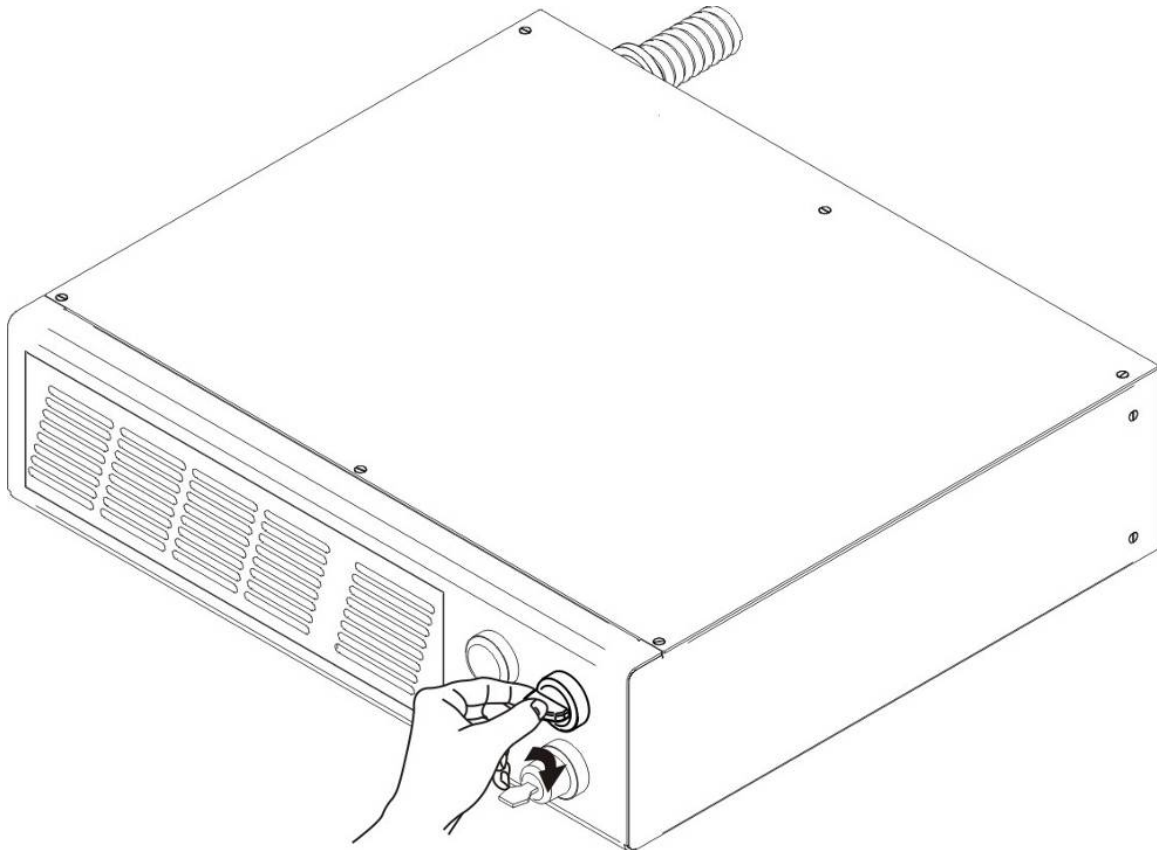

Figure 60: Enable command *ENABLE*.

The laser system is ready to mark. The status LED on the rack will turn red.

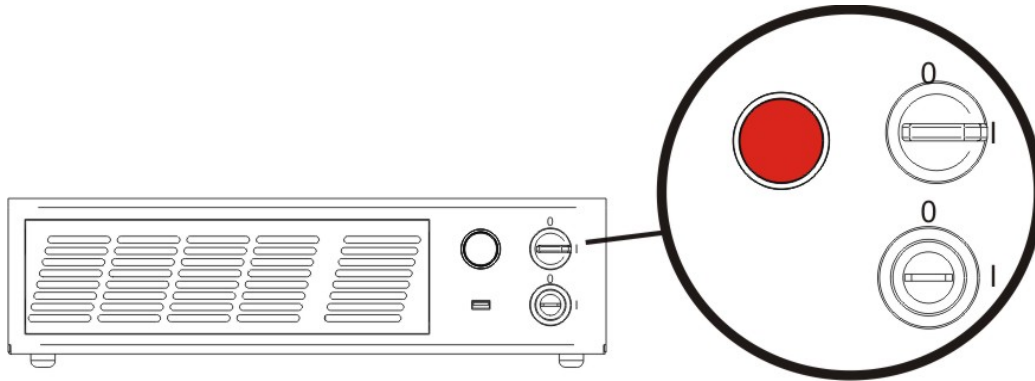

Figure 61: Status LED display.

RESUME TABLE

STATUS	STATUS LED	INPUT STATUS (*)	OUTPUT STATUS (*)
SYSTEM BOOTING UP	BLINKING GREEN (1Hz)	KEY LOW ENABLE LOW	SYSTEM_ALARM ON POWER_ON OFF ENABLE_OUT OFF
WAIT FOR START	STEADY GREEN	KEY LOW ENABLE LOW	SYSTEM_ALARM OFF POWER_ON OFF ENABLE_OUT OFF
WARMING UP	BLINKING ORANGE (1Hz)	KEY HIGH ENABLE LOW	SYSTEM_ALARM OFF POWER_ON OFF ENABLE_OUT OFF
STANDBY SHUTTER CLOSED	STEADY ORANGE	KEY HIGH ENABLE LOW	SYSTEM_ALARM OFF POWER_ON ON ENABLE_OUT OFF
READY	STEADY RED	KEY HIGH ENABLE HIGH	SYSTEM_ALARM OFF POWER_ON ON ENABLE_OUT ON

STATUS	STATUS LED	OUTPUT STATUS (*)
WARNING INVALID START SEQUENCE	BLINKING ORANGE (2Hz)	SYSTEM_ALARM OFF POWER_ON OFF ENABLE_OUT OFF
SYSTEM ERROR	BLINKING RED (2Hz)	SYSTEM_ALARM ON POWER_ON OFF ENABLE_OUT OFF

(*) See paragraph 2.4.3 for more information.

4.1.1 ADVICE ON USING THE SYSTEM

If the marking system is used in manual mode you need to connect Command Box connector as described before. In this way you are able to control the marking system directly on rack front panel.

If the marking system is used in automatic mode it is recommended to enable permanently Key and Enable commands positioned on rack front panel and to use remote signals (*EXT_KEY* and *EXT_ENABLE*) available on Command Box connector. This part is supplied with the product and you can connect external controls wiring connector contacts following pins description on chapter 2.6.

4.2 LOCAL MODE OPERATIONS

The local mode (with monitor, keyboard and mouse connected) is optimal to fully benefit of the ALL-IN-ONE Rack architecture characteristics.

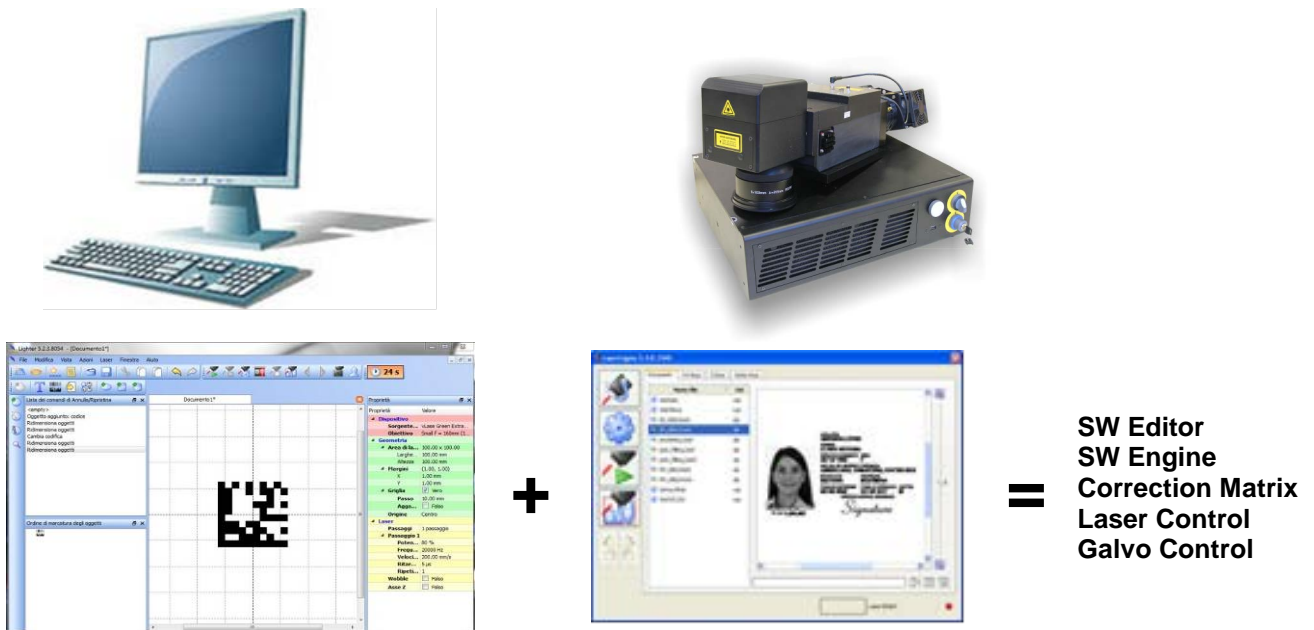

4.3 REMOTE MODE OPERATIONS

Keyboard, mouse and monitor are not necessary in this configuration.

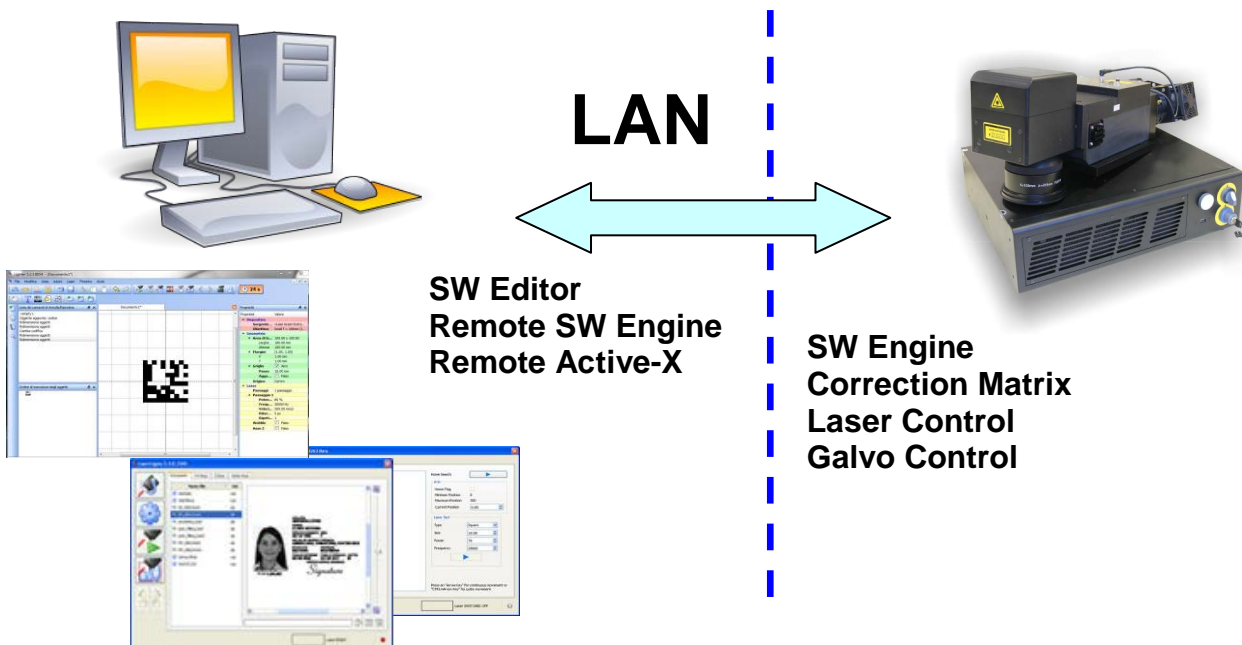

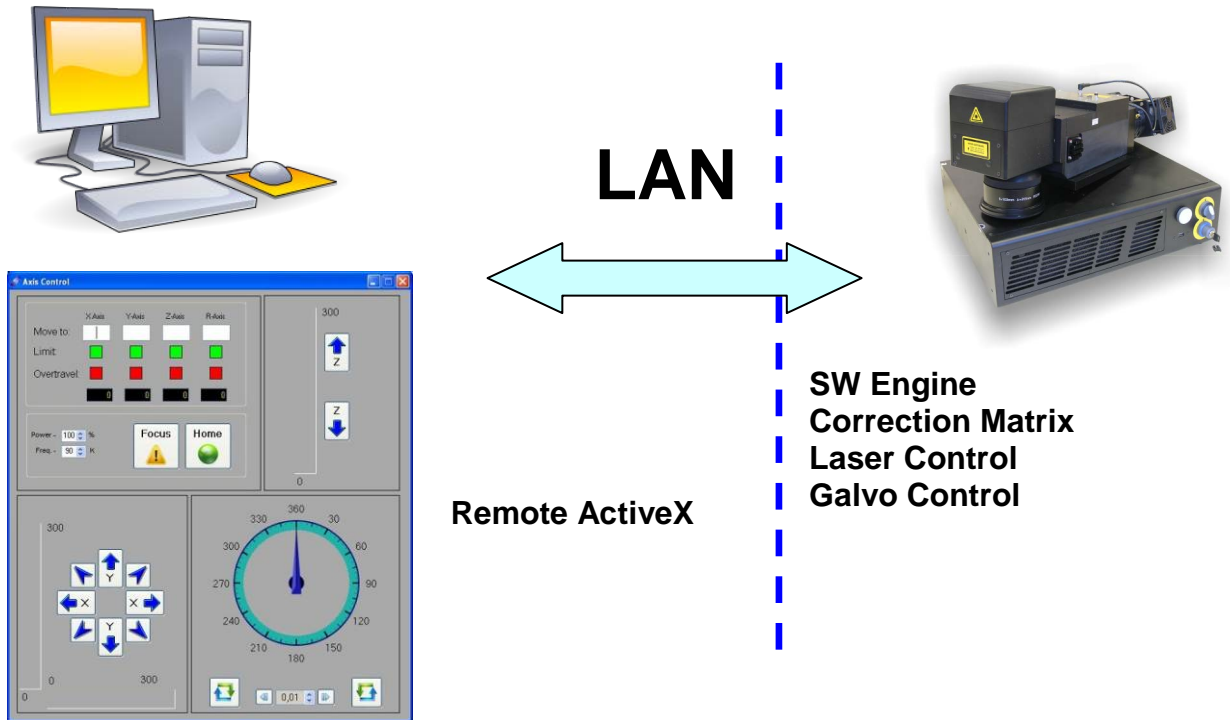

New IP ActiveX allows OEM integrators and end-users to create customized Applications and User Interfaces via Ethernet. Local or remote ActiveX control interface is available with the same commands to allow the use of the same application developed for both local and remote configurations.

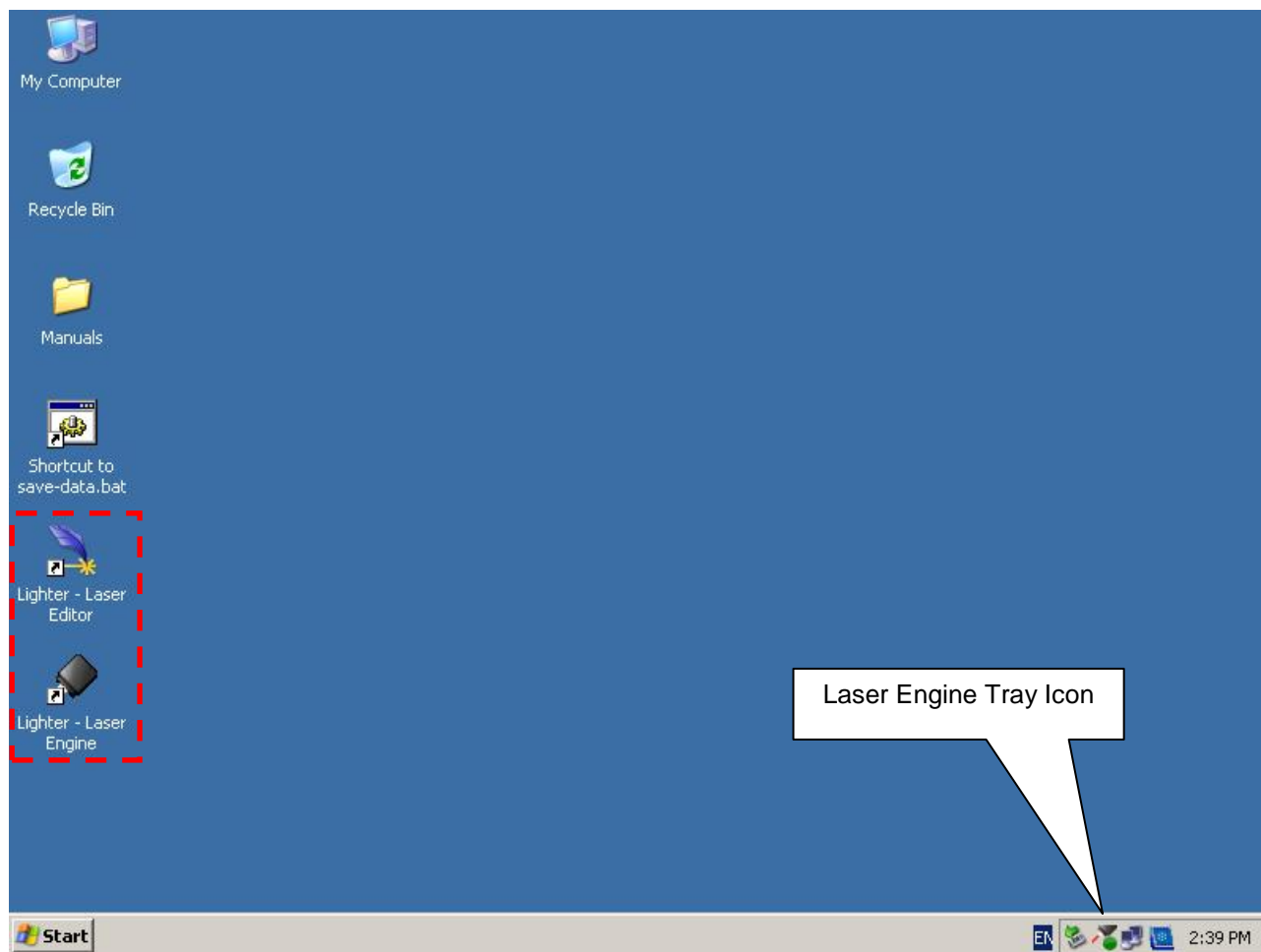

4.4 OPERATING IN LOCAL MODE

Connecting monitor, mouse and keyboard to the laser system (see paragraph 3.1.13) allows the operator to access the console which contains the instruments to operate with laser.



 <p>Lighter - Laser Editor</p>	<p>Lighter Editor is a software that allows to easily mark or engrave product identification information such as 2D matrix codes, barcodes, text, alpha-numeric serial numbers, date codes, part numbers, graphics and logos in any production environment.</p> <p>With Laser Editor you can:</p> <ul style="list-style-type: none"> ○ edit graphic layouts ○ set laser parameters ○ set system configuration ○ control the integrated I/O module for axis management ○ create automated procedures ○ create programs using Lighter programming language
 <p>Lighter - Laser Engine</p>	<p>Lighter Engine is an application automatically loaded at start-up that allows to operate the marking system. Lighter Engine is present in the tray icon.</p> <p>With Laser Engine you can:</p> <ul style="list-style-type: none"> ○ monitor the system status ○ select a saved document, display limits using a red laser pointer, watch the marking preview and do marking tests ○ switch between Manual/Auto mode (engraving operations controlled by operator or external signals)

4.4.1 HOW TO CREATE AND EDIT YOUR FIRST GRAPHIC DOCUMENT

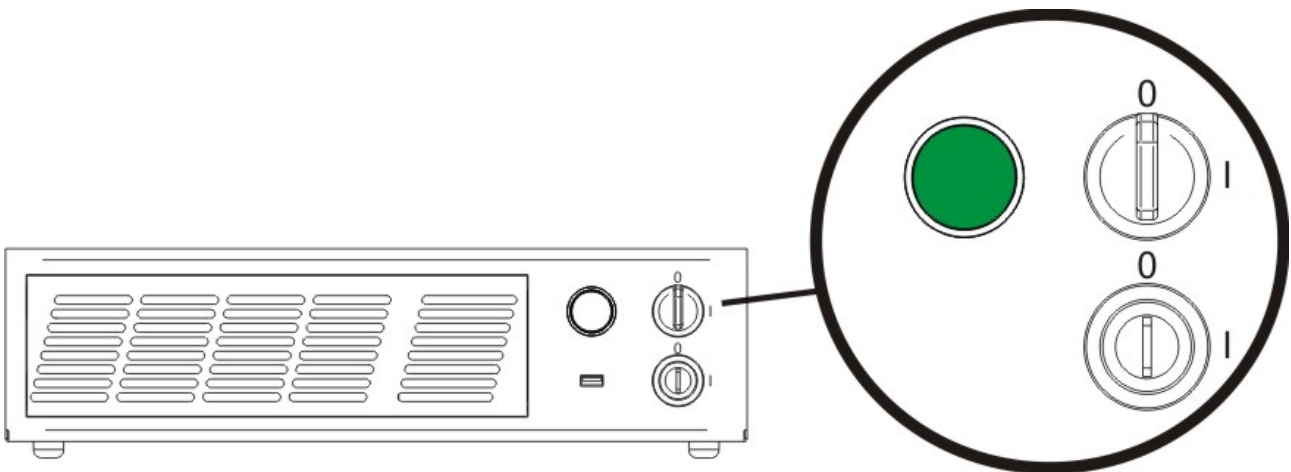

SIGNAL	STATUS
EXT_KEY	OFF
EXT_ENABLE_A	OFF
EXT_ENABLE_B	OFF

In “*WAIT FOR START*” status, double click on **Laser Editor** icon to start the layout editor application



Click on the document type selector and choose **Layer**:

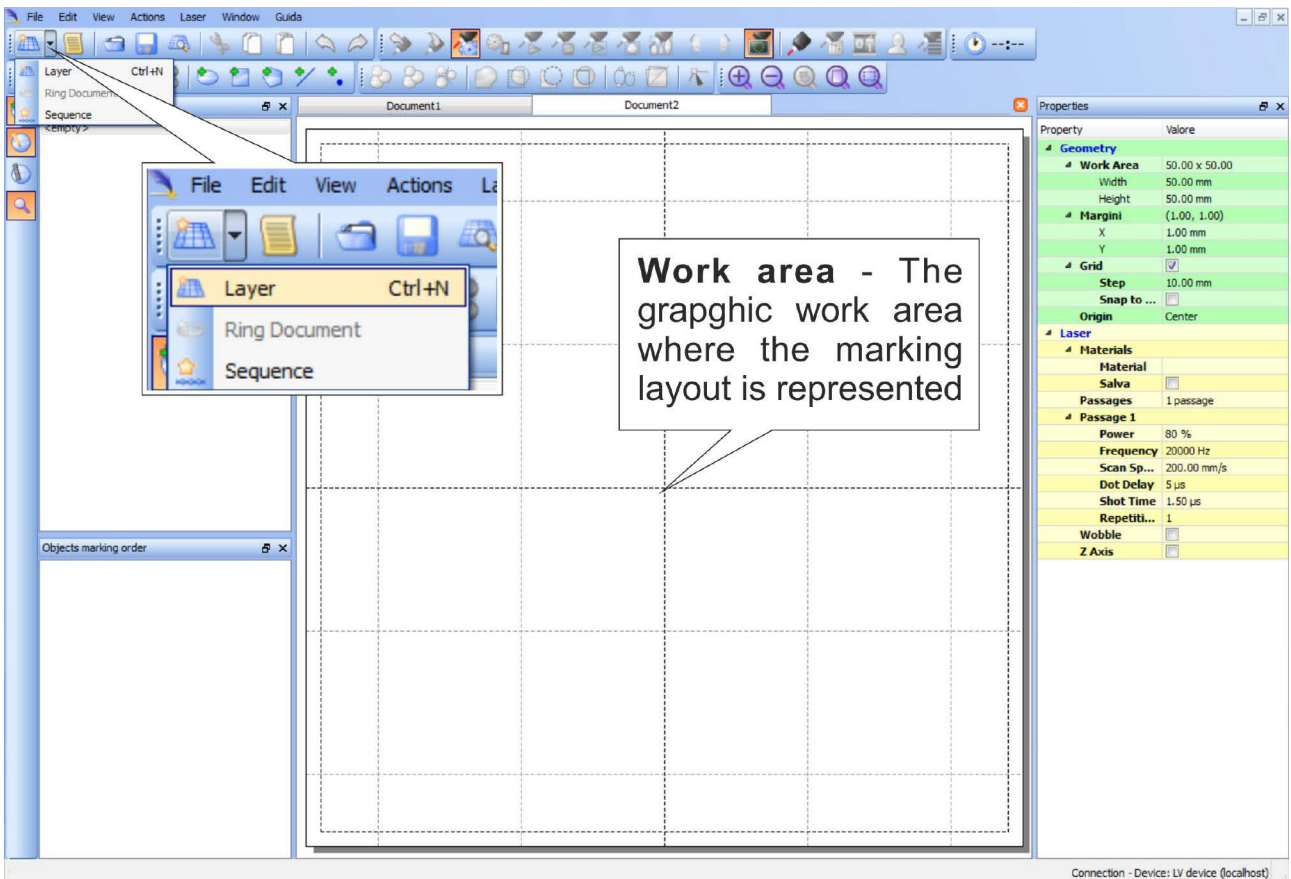

Click on the **Text String** icon in the **Object toolbar** to add a string object to the layer:

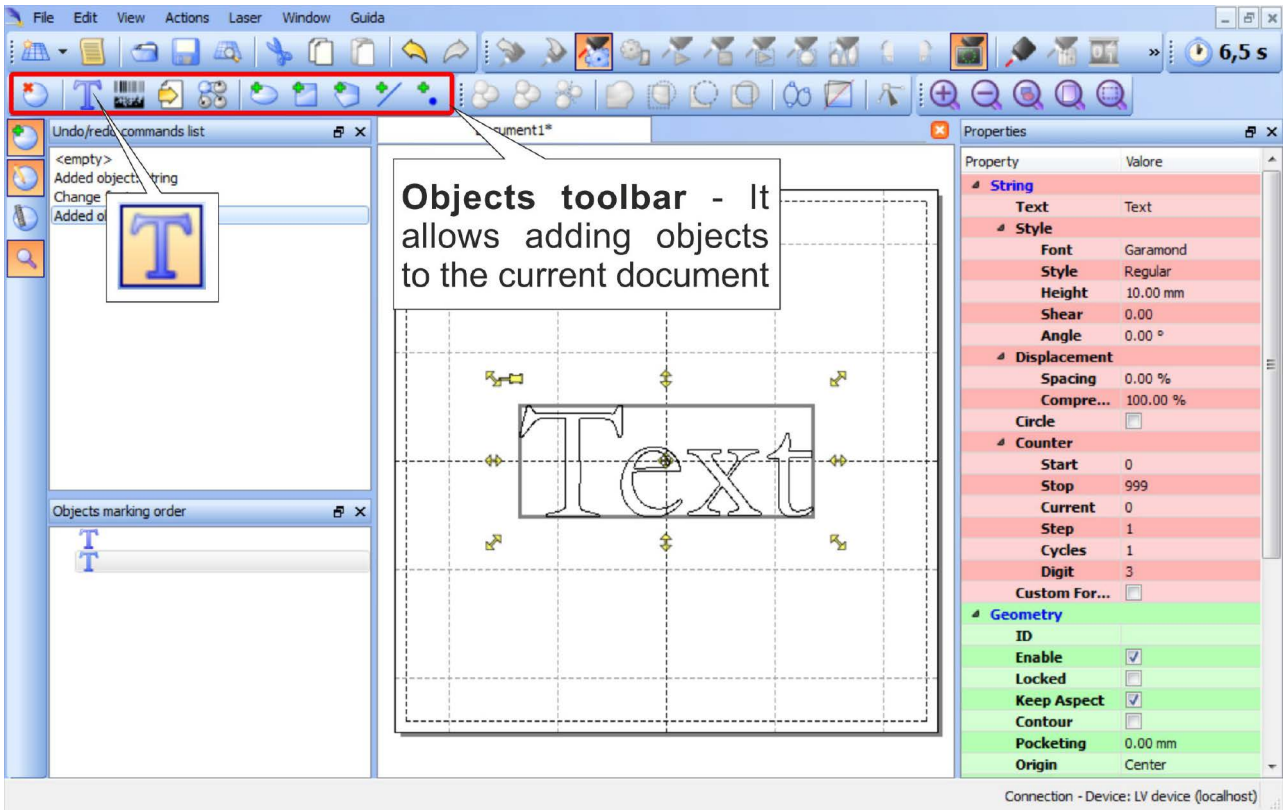

Edit String properties such as value, font, style, etc. using the **Properties browser**:

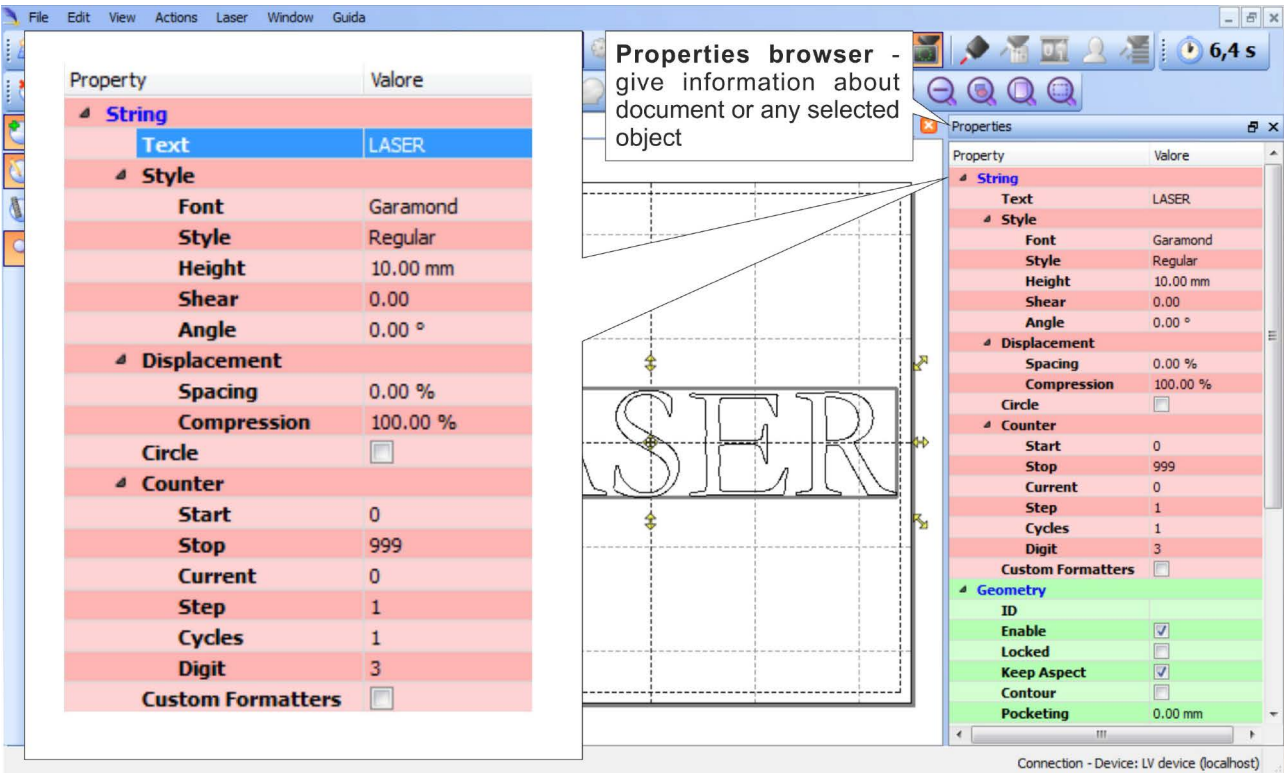

Edit Filling properties such as filling type, interline, etc. using the **Properties browser**:

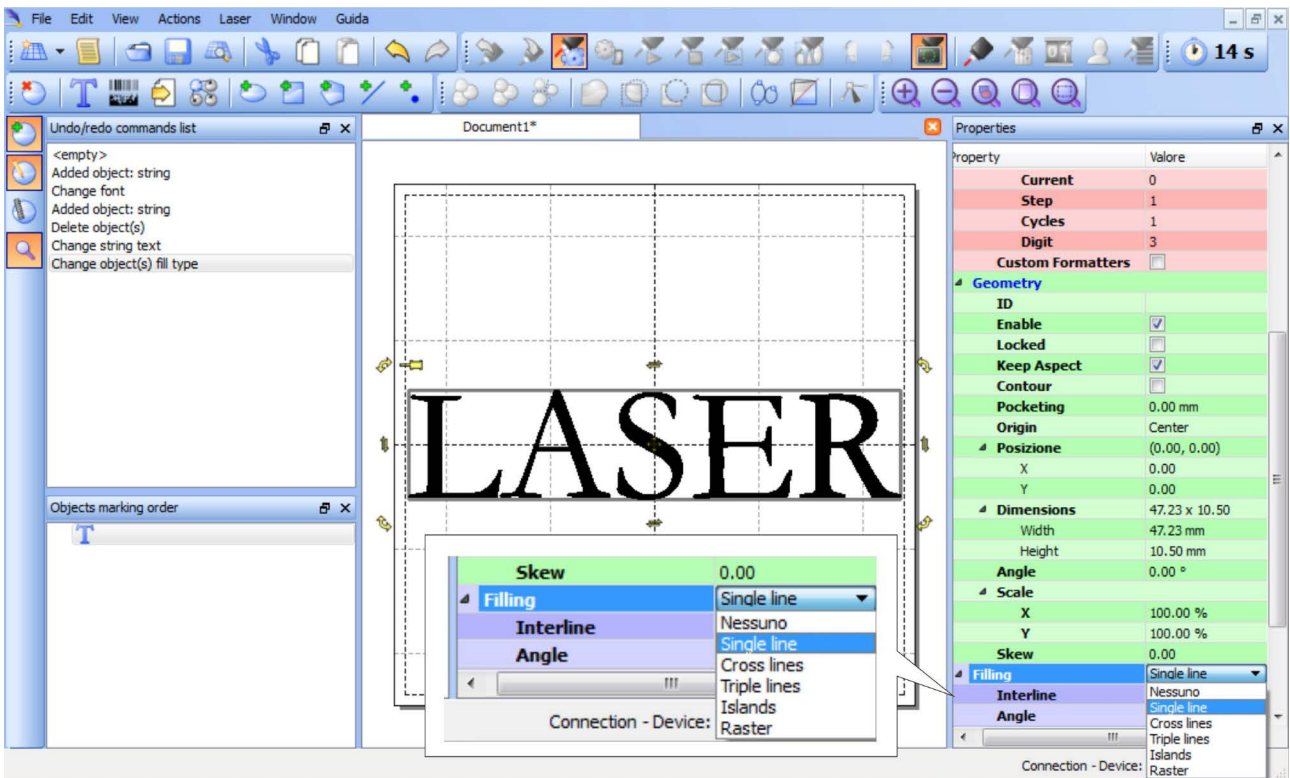

4.4.2 HOW TO TEST AND ENGRAVE YOUR DOCUMENT

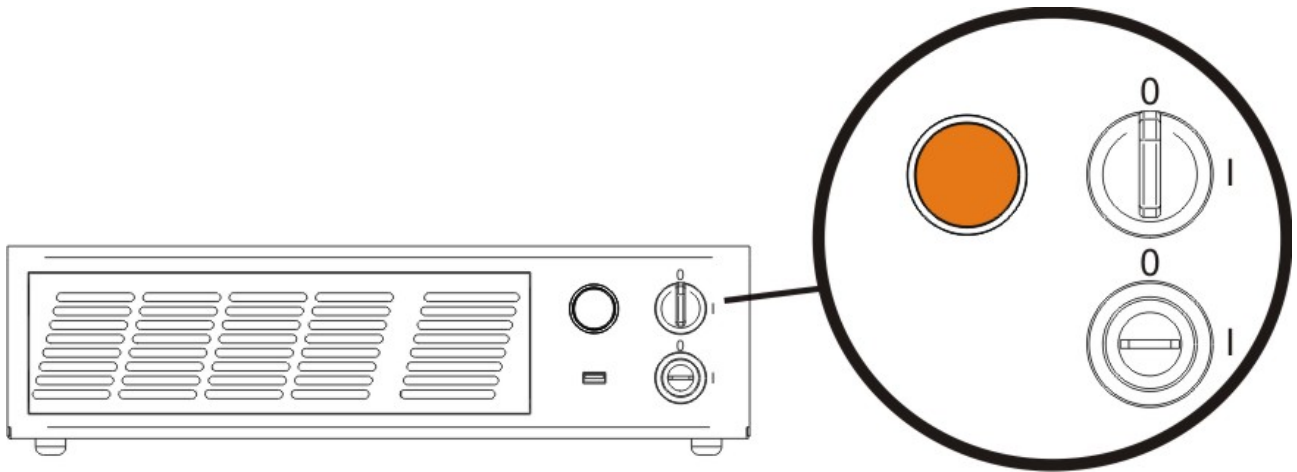

SIGNAL	STATUS
EXT_KEY	ON
EXT_ENABLE_A	OFF
EXT_ENABLE_B	OFF

In “*STANDBY SHUTTER CLOSED*” status, press **Limits All** button in the **Laser Toolbar** to adjust the object position in the marking field:

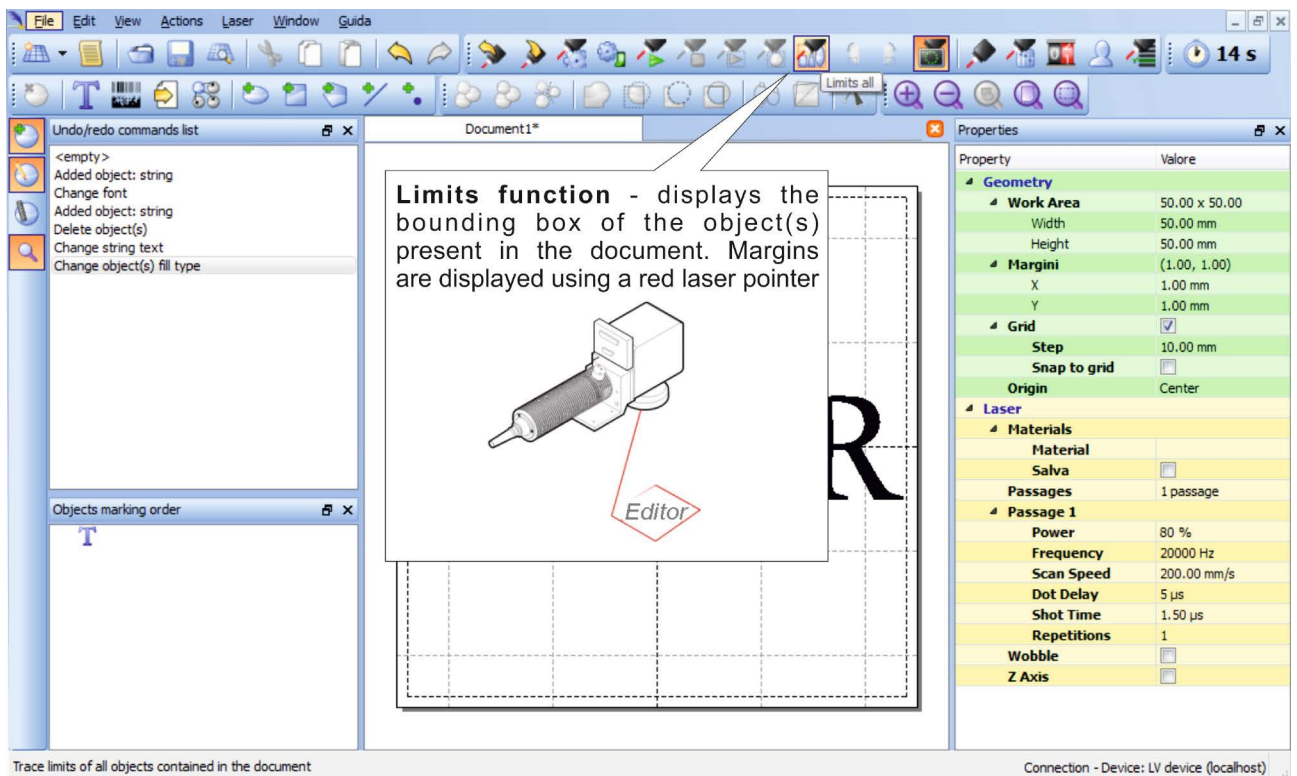

In “READY” status, adjust the Laser parameters using the **Properties browser**:

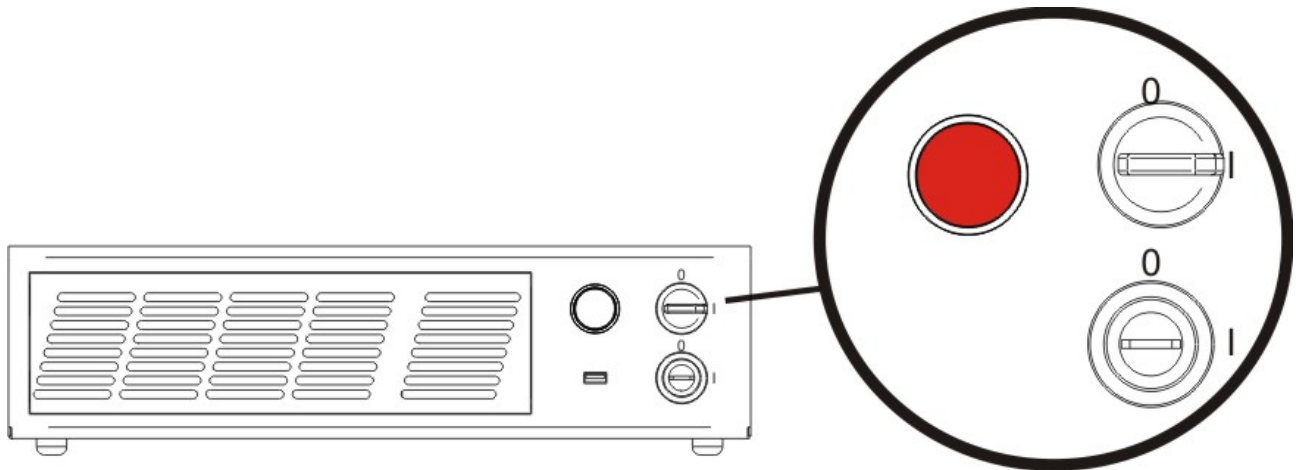

SIGNAL	STATUS
EXT_KEY	ON
EXT_ENABLE_A	ON
EXT_ENABLE_B	ON

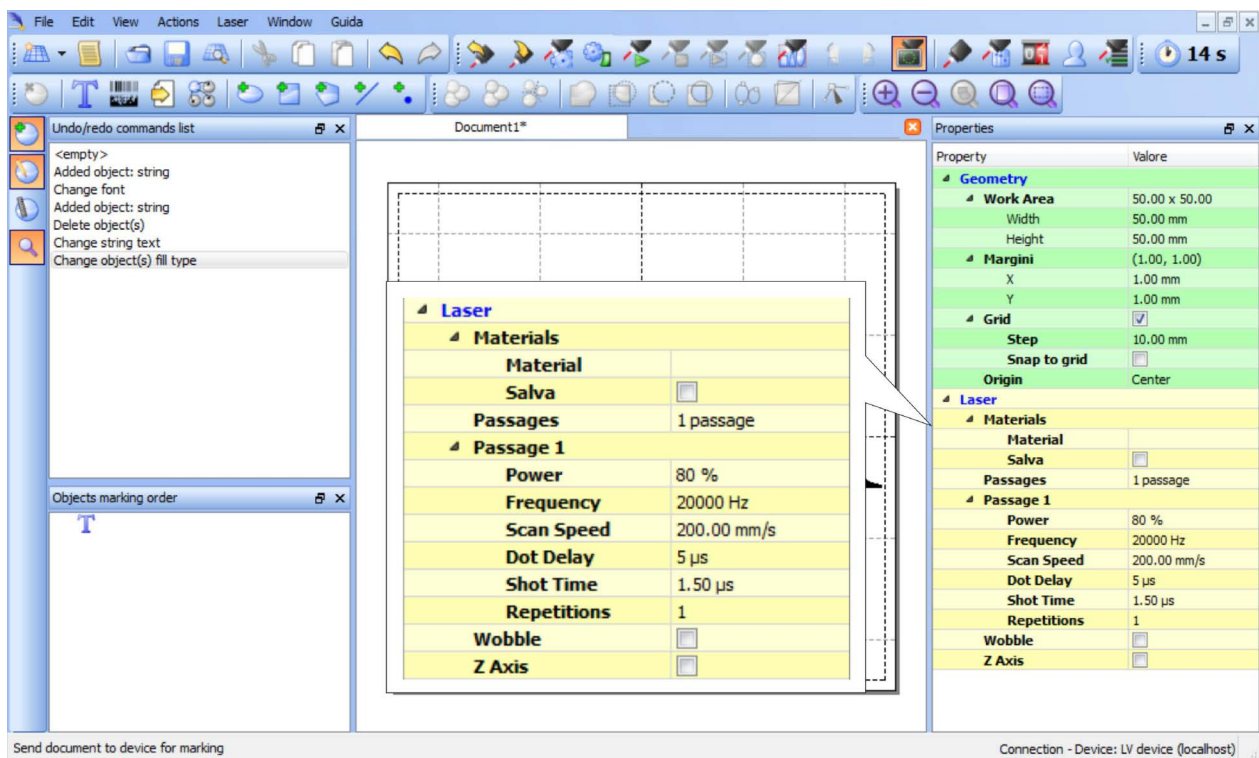

Press **Send Marking** button in the **Laser Toolbar** to start the marking process:



4.4.3 HOW TO USE EXTERNAL SIGNALS TO ENGRAVE YOUR DOCUMENT

Automate the marking process allowing documents to be marked using external *START_MARKING* and *STOP_MARKING* signals, that can be generated by PLC or other external devices.

Click on **Save to Device** button to save the layout in the marking system memory:

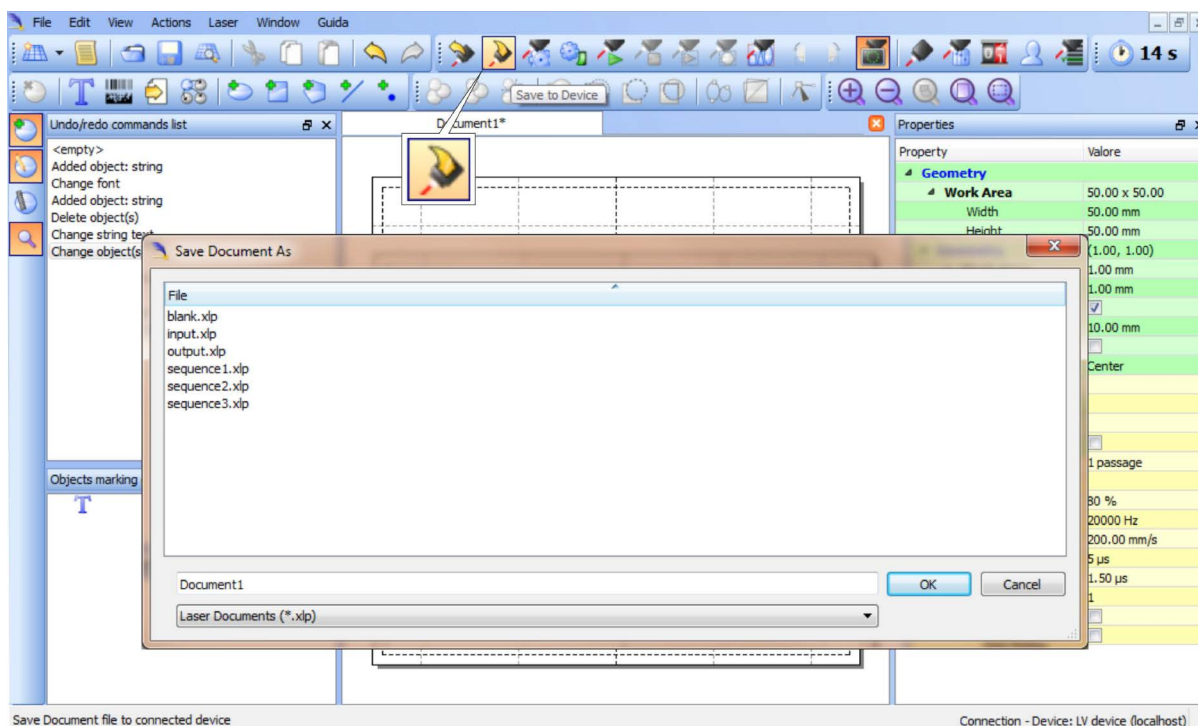

Click on **Show Laser Engine** button to display Laser Engine window:

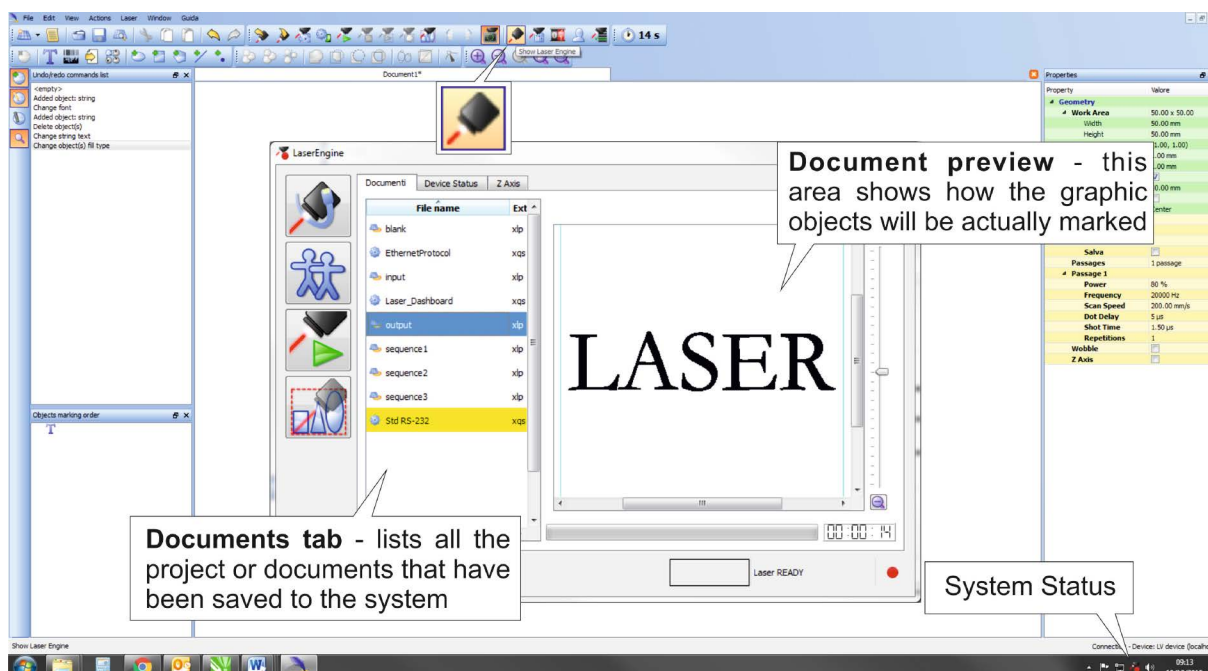

AUTO/MANUAL Mode button allows switching between the two available working modes:

- Auto mode: the engraving operations are executed automatically using external signals.
- Manual mode: used for displaying the margins of the graphic objects to be marked and testing layouts.

Select the document from the list and click on **To Auto Mode** button:

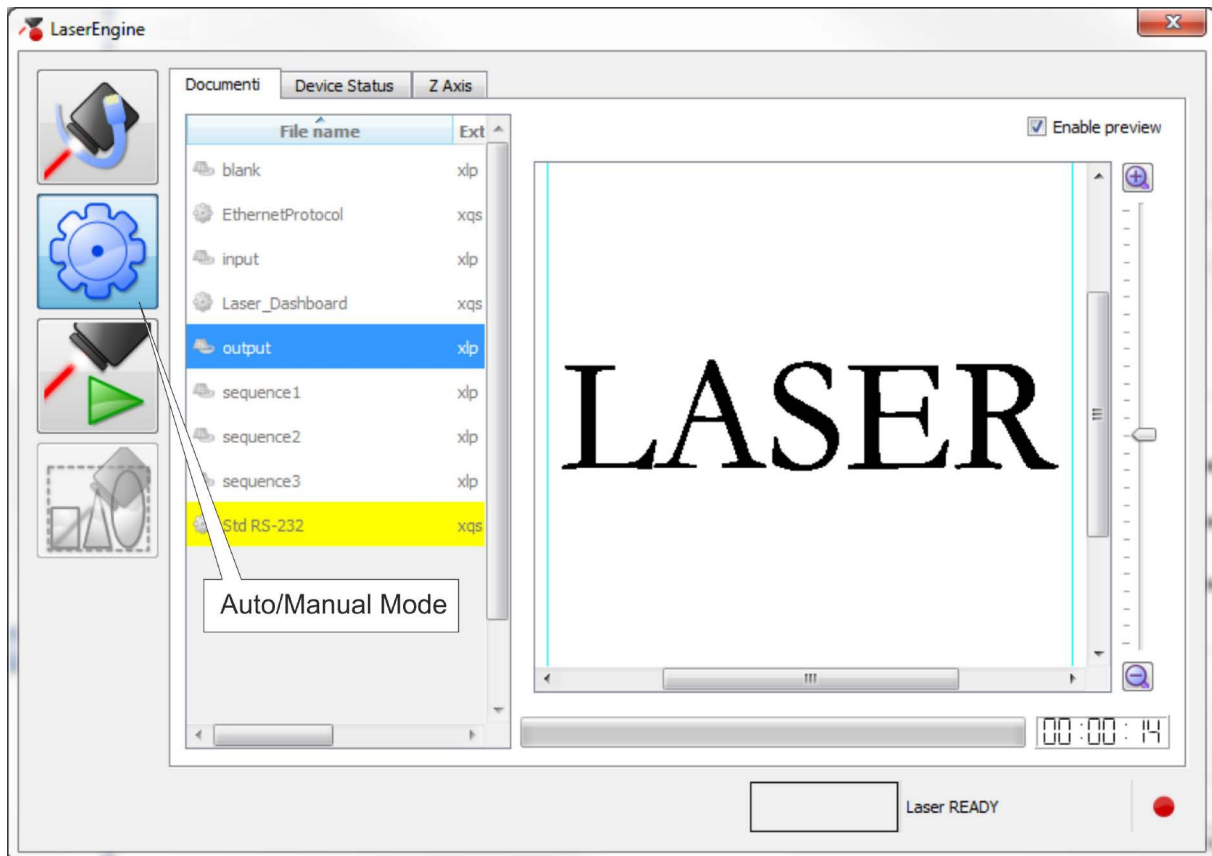

The laser system is ready to mark document using external *START_MARKING* and *STOP_MARKING* signals:



4.5 THERMALIZATION AND SUPPRESSION OF GIANT PULSES

Thermalization is useful in order to obtain a good marking quality.

To obtain uniform markings and work processes is important to keep Nd:YVO4 crystal constantly pumped. This operation is called thermalization and is implemented supplying the laser diode with a suitable level of current. In this way a certain amount of pumping radiation at 808nm excites the crystal “but being the Q-switch closed” no laser radiation is emitted by the system.

With the Vlase™ source, this procedure can be implemented using Software Thermalization.

Software thermalization

Software thermalization is implemented automatically by the Lighter marking software and consists in defining, within the marking project, a certain thermalization level at which the crystal is maintained during the non-emission intervals. It is generally recommended to keep the level of thermalization similar to the power level used for the marking or slightly lower.

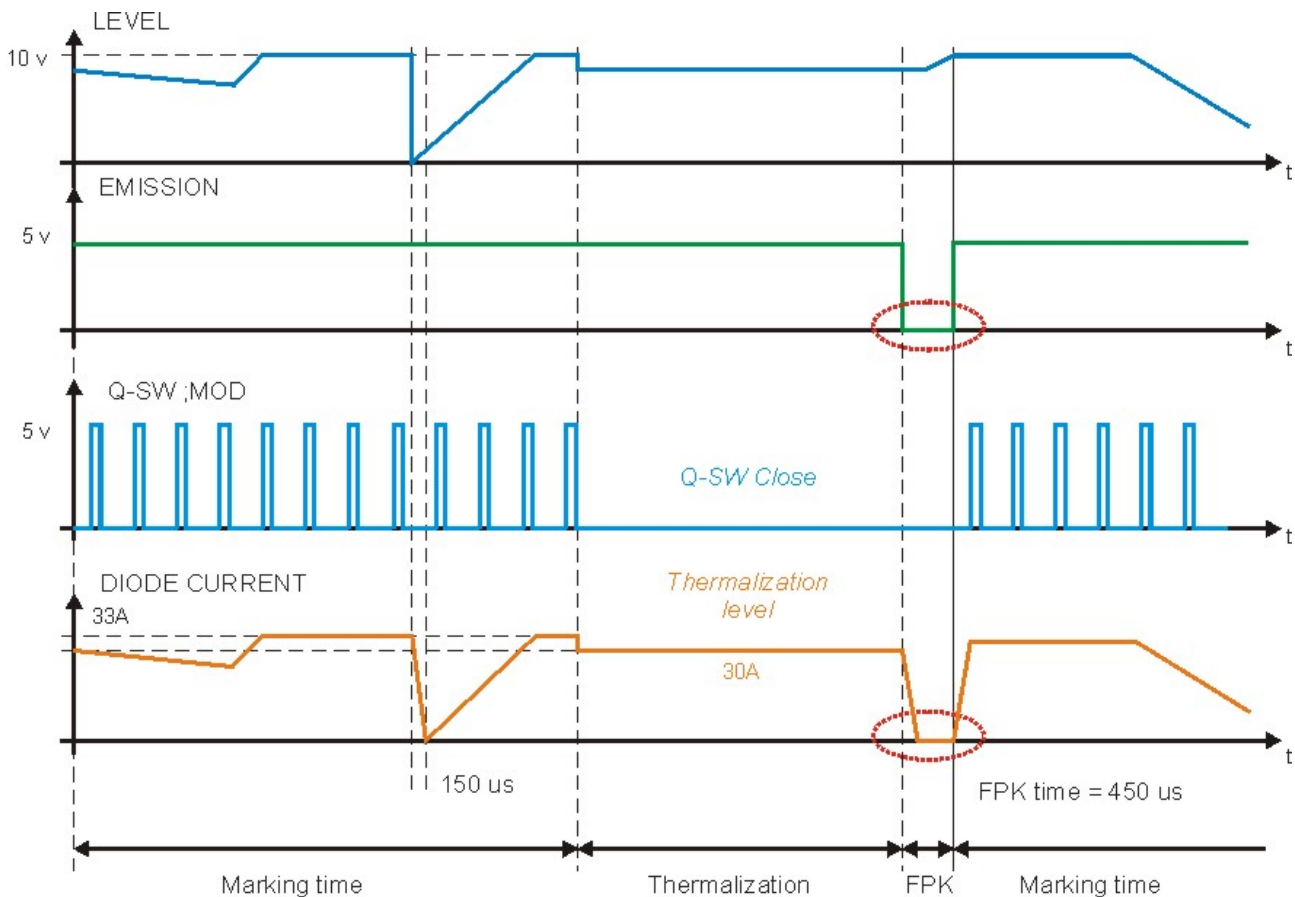

Figure 62: Temporal diagram of Software Thermalization.

As you can see in the graph shown in the Figure, during the marking phase the Q-Switch Modulation signal determines the frequency with which the laser pulses are generated, the effect of the LEVEL signal is a corresponding change in the laser diode current.

Please note that, in order for this to occur, the EMISSION signal has to be active.

NOTE:



Please also note that the current supplied to the laser diode is intentionally forced to have rising and falling times in the range of 150us. This protection from fast commutations (generated either from fast changes of LEVEL signal or from EMISSION signal front) is intended to reduce damage risk and extend lifetime of the diode itself.

During the thermalization phase, the EMISSION signal stays active, while the LEVEL signal goes into a pre-set thermalization level (i.e. 90%) and the Q SW MOD signal stays fixed at 0 V.

At the end of the thermalization phase, before starting another marking phase, the FPK (First Pulse Killing) procedure needs to be implemented in order to discharge the crystal, thus avoiding the generation of "giant" pulses which may cause marking defects as well as damages to the internal optics of the resonator.

To discharge the crystal, the Q-Switch is kept closed (Q SW MOD signal at 0 V) and the EMISSION signal is brought to a 0V level for at least 450 microseconds, so as to cut off the current in the laser diode and consequently the pumping of the crystal (FPK delay).

Laser source	Frequency interval	Operation in Continuous Wave (CW)	Q-switch opening time (Shot Time)	Optimal FPK delay
Vlase™ UV 3 W	20 kHz ÷ 80 kHz	NO	1,5 µs	450µs

WARNING!



It is strongly recommended **NOT** to change FPK Shot time delay and set, because they have been optimized to ensure the safety of the marking system and the performance marking linked to the high stability of the laser pulses.

5 CUSTOMIZE THE SYSTEM'S SOFTWARE

5.1 CHANGE O.S. LANGUAGE AND KEYBOARD LAYOUT

The marking system allows you to personalize the operating system changing the language used in menus and dialogs, languages you can use to enter text and keyboard layout.



NOTE:

In order to perform this setting it is necessary to connect mouse, keyboard and monitor to the system (see paragraph 3.1.13).

- Turn OFF and ON the system and wait the end of the booting-up (the status LED on the rack must be steady green)
- From the main screen click on **Start > Control Panel**

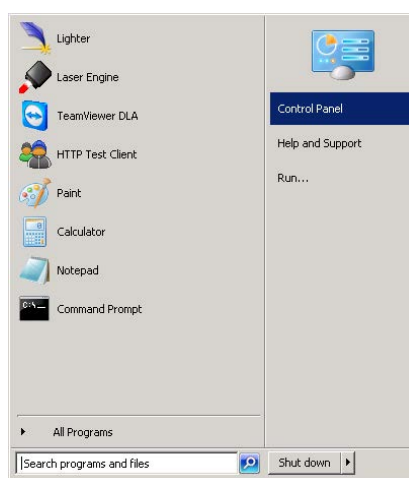

- Select **Change display language**:

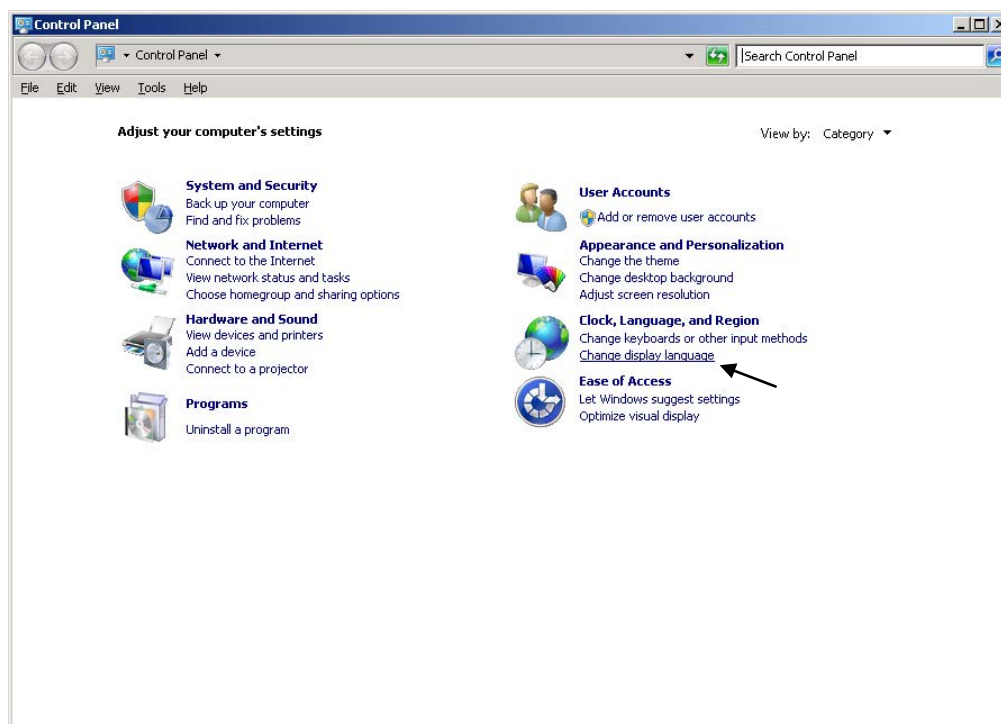

- In **Keyboards and Languages** select and choose the desired language.

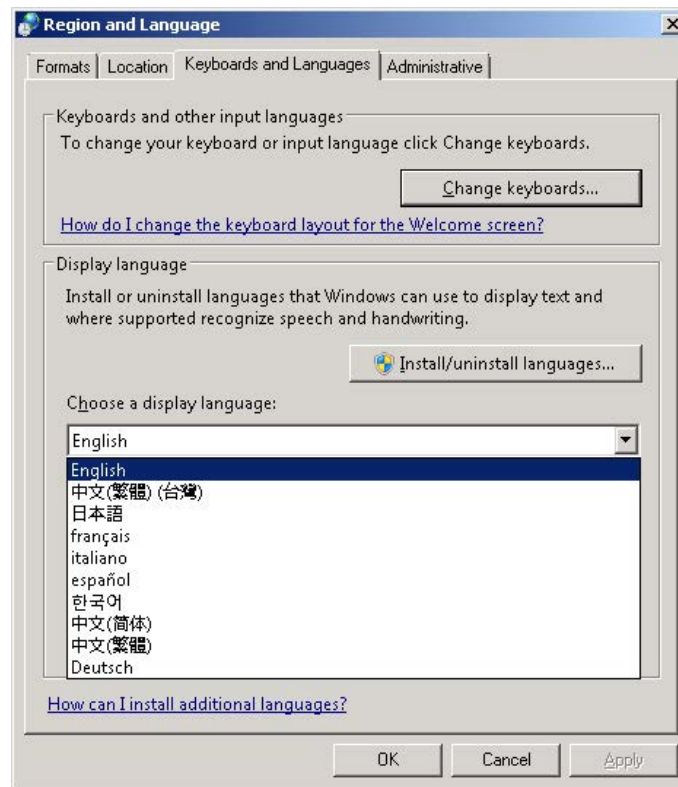

- Select **Change keyboards** to change your keyboard or input language:

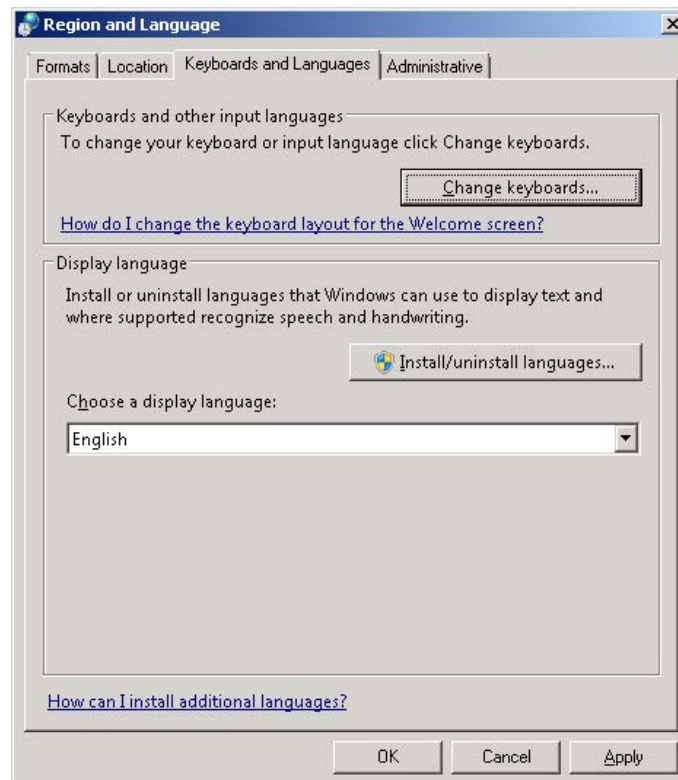

- o Select now input languages and press **OK**:

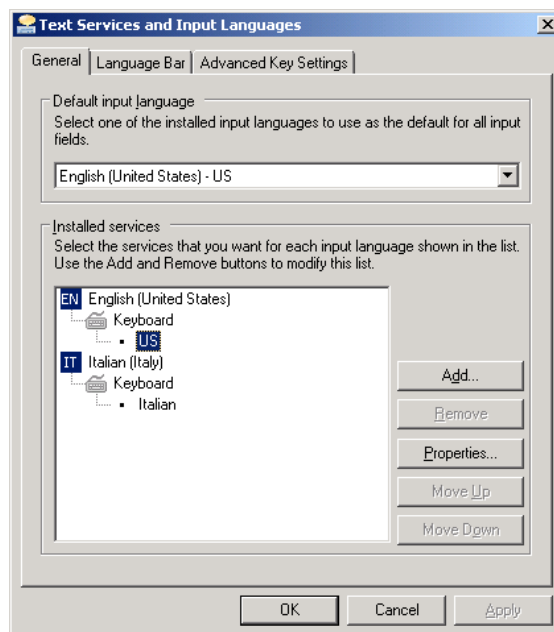

- o Close all the open screens and double click on shortcut to `save-data.bat` icon in the Desktop screen.
- o A message advise you to restart or shutdown the system in order to permanently save data. Press **OK**:

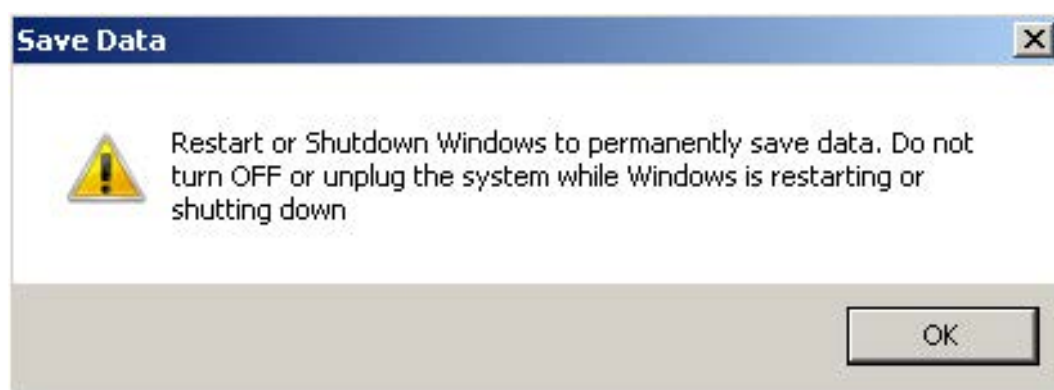

- o **Shut down** the system in order to save the new settings:



WARNING!

DO NOT turn **OFF** or **UNPLUG** the system while Windows® is shutting down.

- o **WAIT** until system shuts down automatically (black screen)
- o Power off the system to complete installation

5.2 CHANGE LAN CONFIGURATION AND IP ADDRESS

The system allows you to change the LAN configuration and IP address.



NOTE:

In order to perform this setting it is necessary to connect mouse, keyboard and monitor to the system (see paragraph 3.1.13).

- o Turn OFF and ON the system and wait the end of the booting-up (the status LED on the rack must be steady green)
- o From the main screen click on **Start > Control Panel**

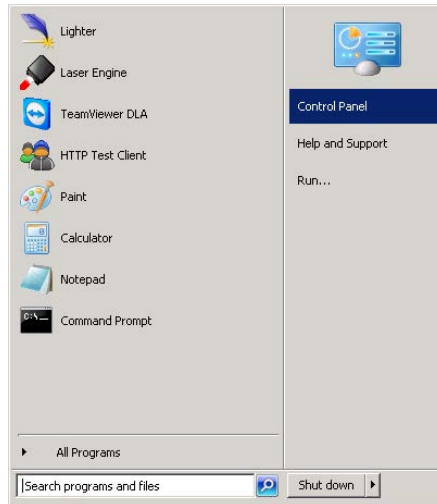

- o Select **View network status and tasks:**

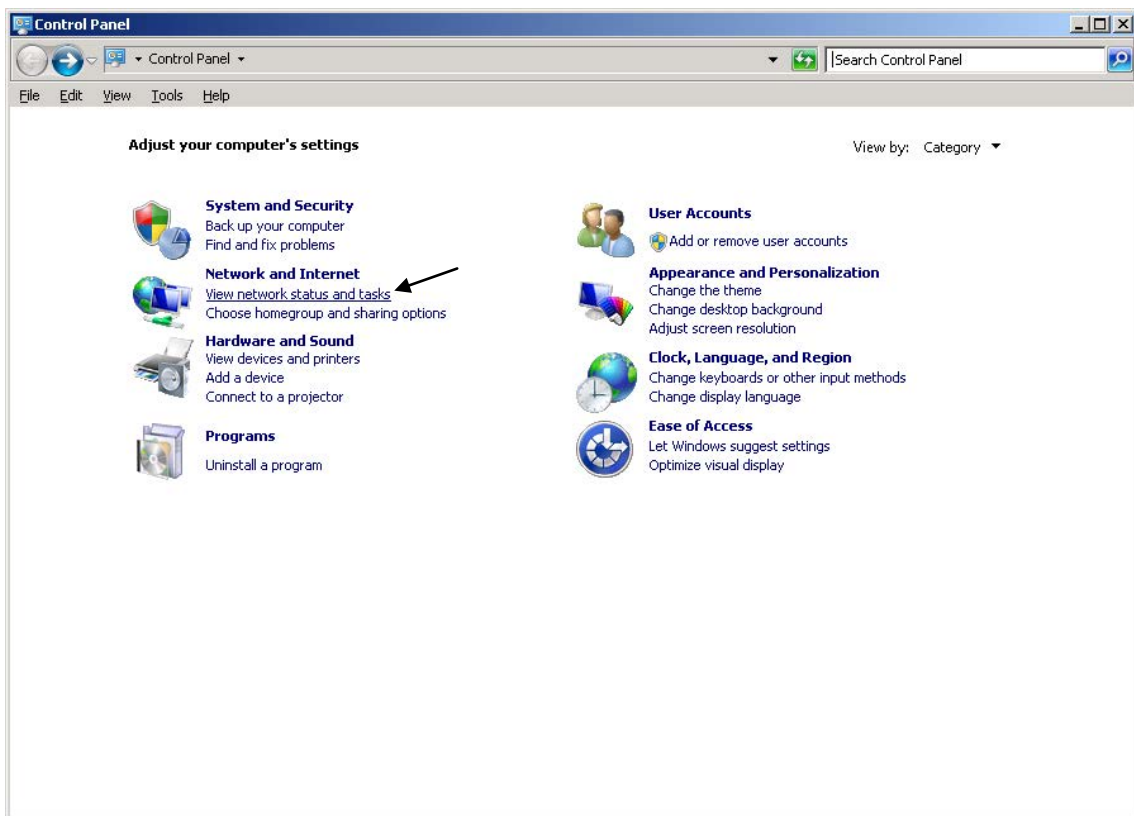

- In the **Network and Sharing Center** screen select **Change adapter settings**:

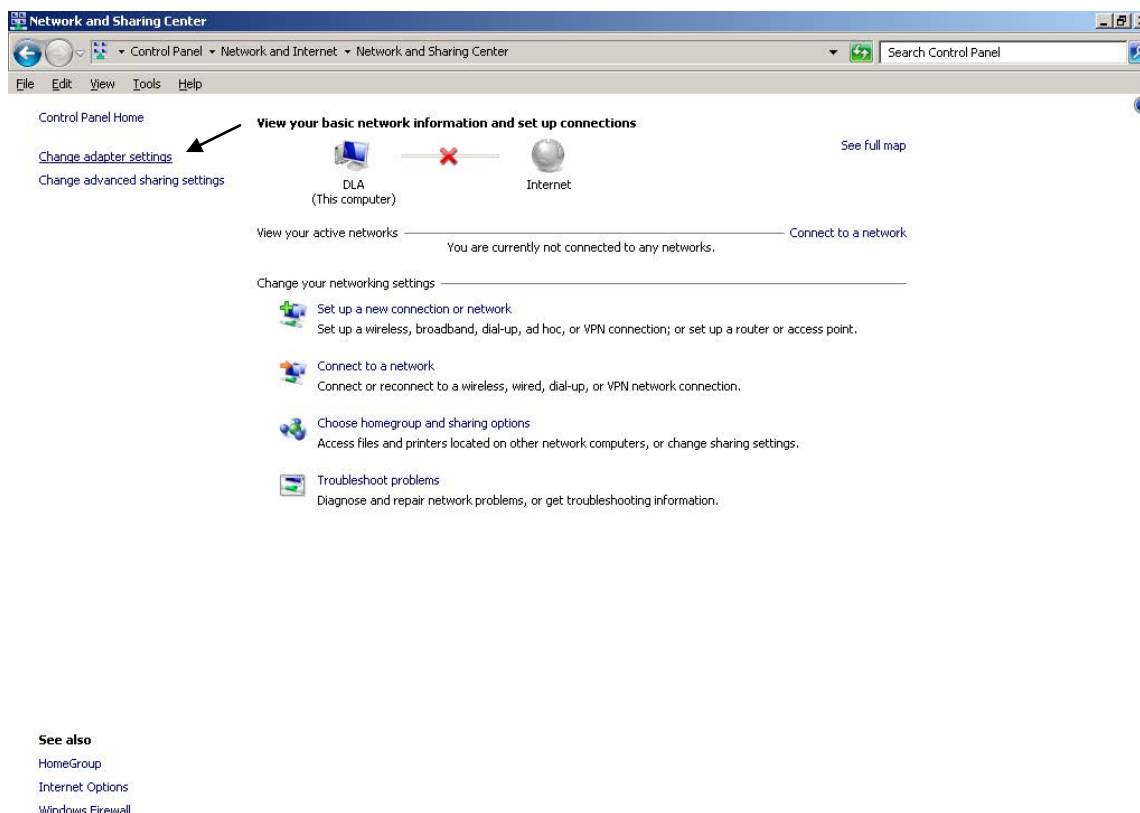

- In the **Network Connections** screen double click on **Local Area Connection**

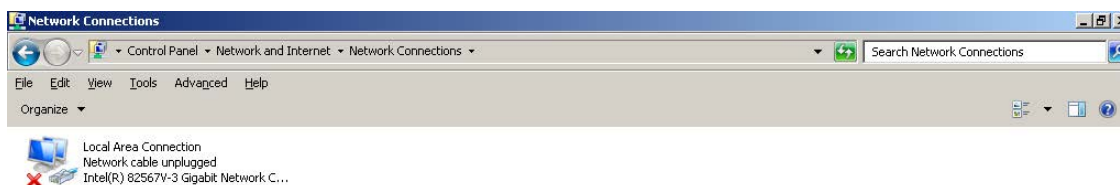

- In the **Local Area Connection Properties** screen double click on **Internet Protocol Version 4 (TCP/IPv4)**
- In the **Internet Protocol Version 4 (TCP/IPv4) Properties** you can change the IP address and configuration

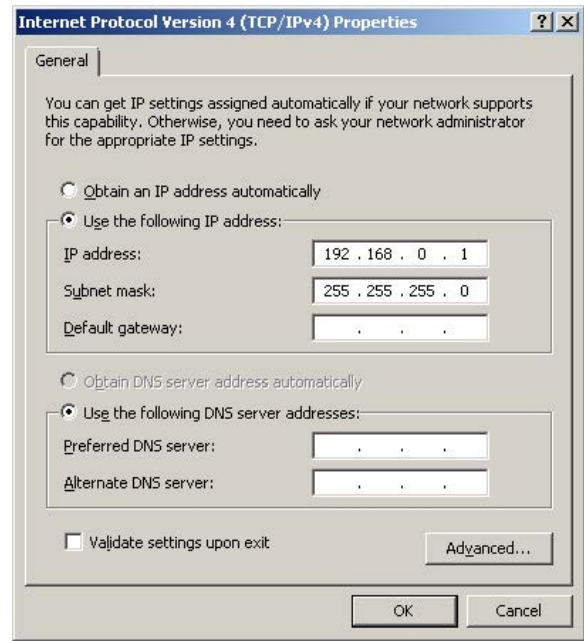
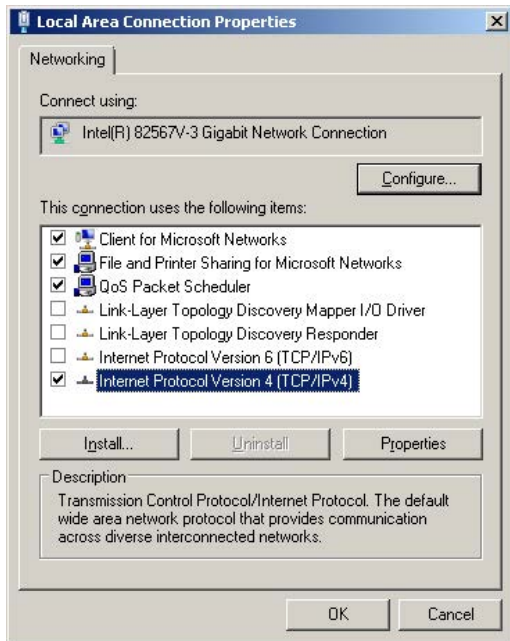

- Close all the open screens and double click on shortcut to `save-data.bat` icon in the Desktop screen.
- A message advise you to restart or shutdown the system in order to permanently save data. Press **OK**:

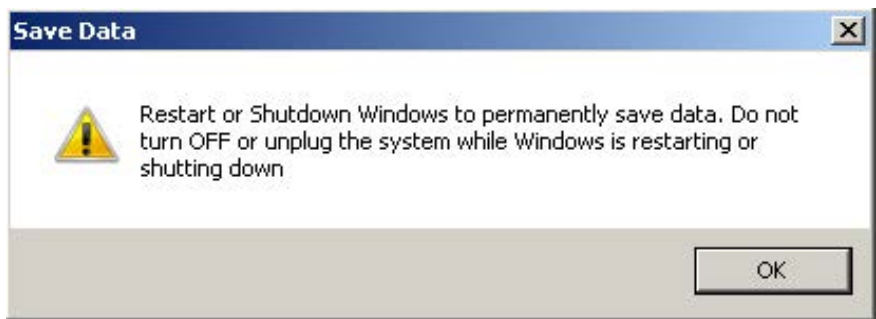

- **Shut down** the system in order to save the new settings:



WARNING!
DO NOT turn **OFF** or **UNPLUG** the system while Windows® is shutting down.

- **WAIT** until system shuts down automatically (black screen)
- Power off the system to complete installation

5.3 CHANGE VIDEO SETTING

The system allows you to change the Video setting.



NOTE:

In order to perform this setting it is necessary to connect mouse, keyboard and monitor to the system (see paragraph 3.1.13).

- Turn OFF and ON the system and wait the end of the booting-up (the status LED on the rack must be steady green)
- From the main screen click on **Start > Control Panel**

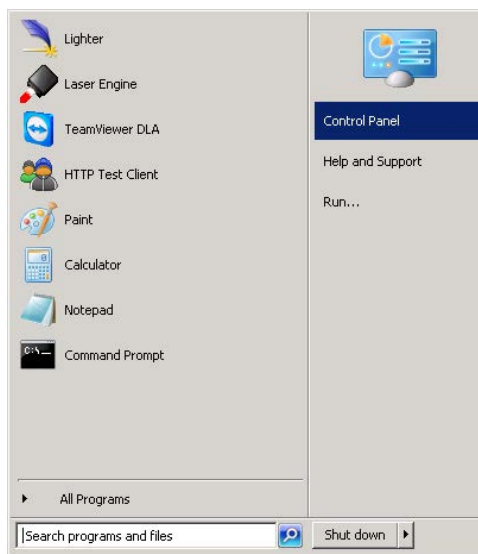

- Select **Adjust screen resolution**:

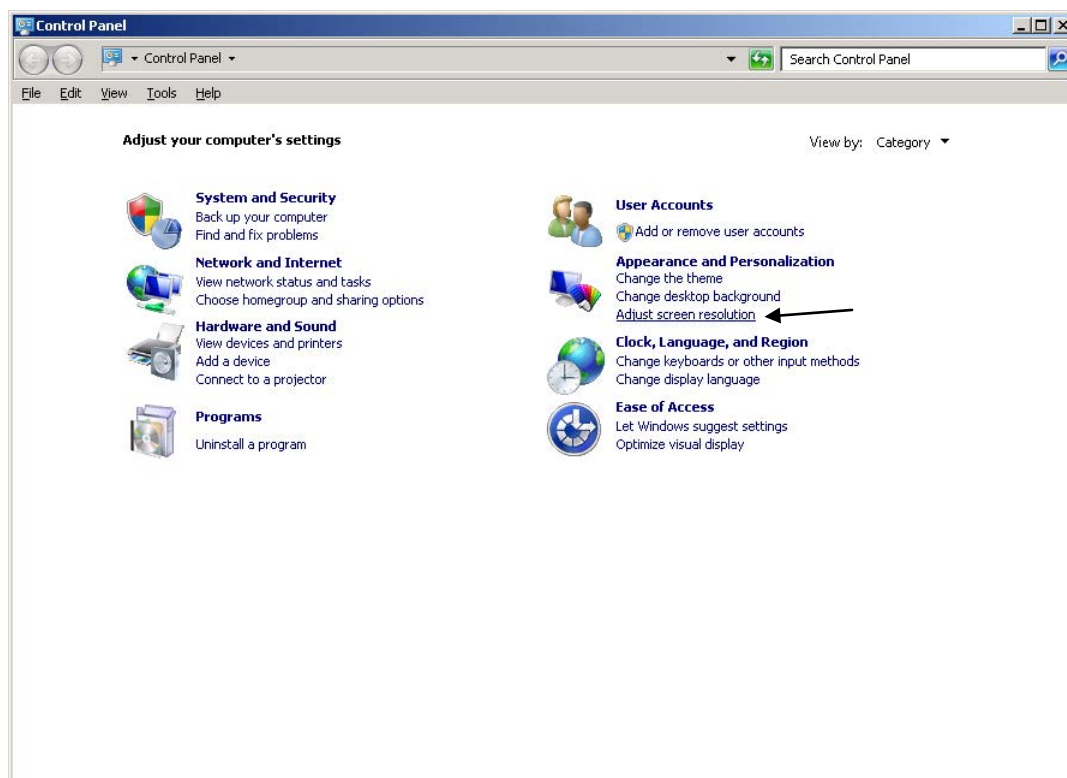

- o In the **Screen Resolution** window select the desired Screen resolution and Colour quality:

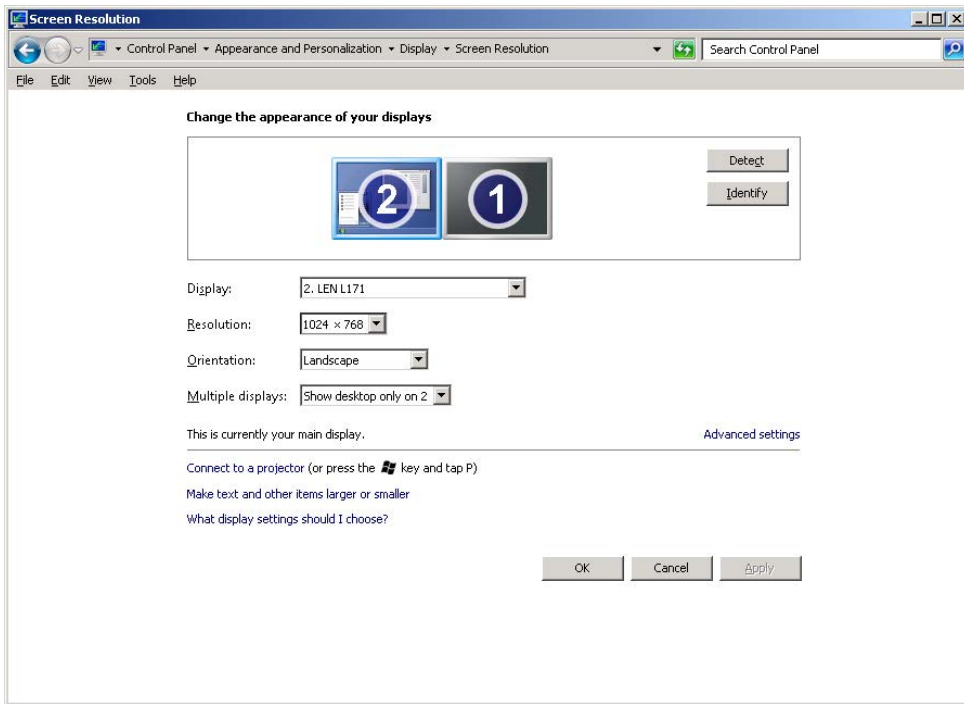

- o Close all the open screens and double click on shortcut to `save-data.bat` icon in the Desktop screen.
- o A message advise you to restart or shutdown the system in order to permanently save data. Press **OK**:



- o **Shut down** the system in order to save the new settings:



WARNING!
DO NOT turn **OFF** or **UNPLUG** the system while Windows® is shutting down.

- o **WAIT** until system shuts down automatically (black screen)
- o Power off the system to complete installation

5.4 REMOTE DESKTOP CONNECTION

To connect the laser system to a remote Windows® based computer, follow these steps:

- Turn on the marking system
- Make sure that both the marking system and remote computer are connected to the LAN
- Click **Start > All Programs > Accessories**, and then click **Remote Desktop Connection**
- Click **Options**
- In the Computer list, type the host name or the IP address of the computer to which you want to connect
- Type the user name, password, and domain (if applicable) of an account to which you have allowed remote access into the corresponding boxes, and then click **Connect**

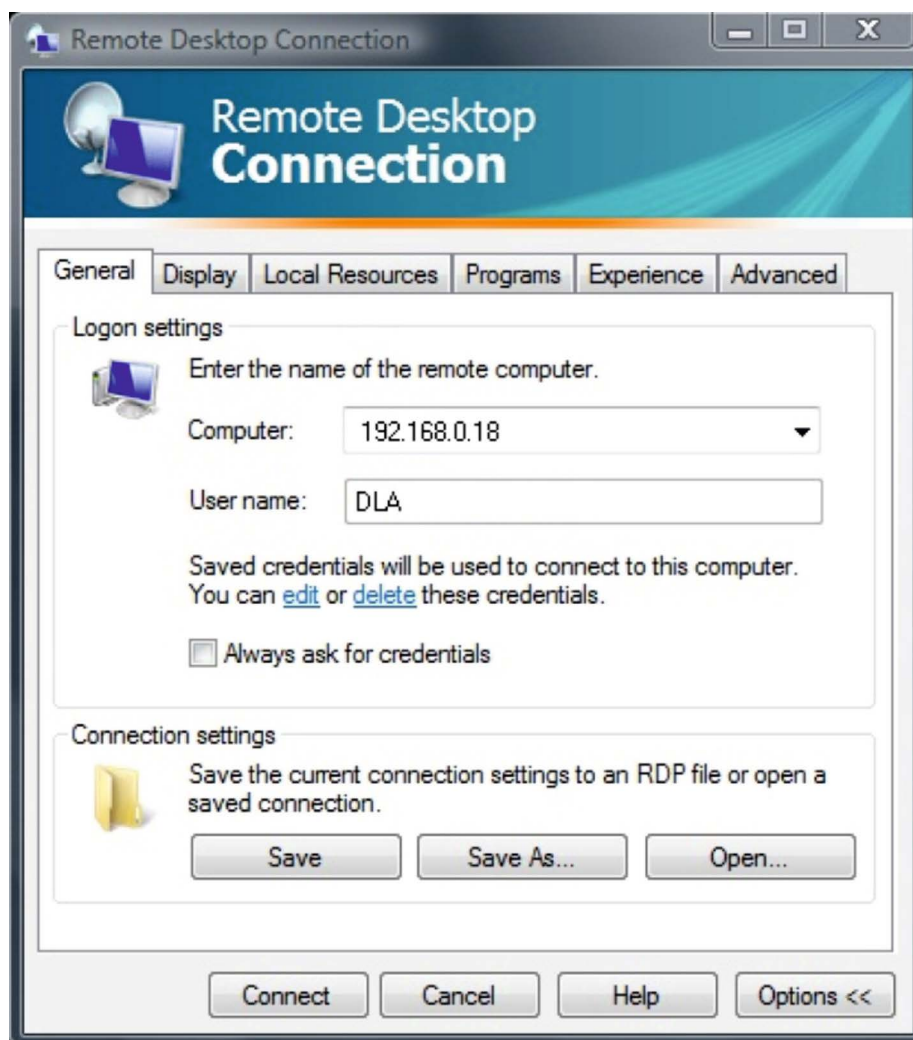

- In the **Log On to Windows**[®] dialog box that appears, type the password of the account with remote access privileges into the Password box:

User name: **DLA**
Password: **dla**

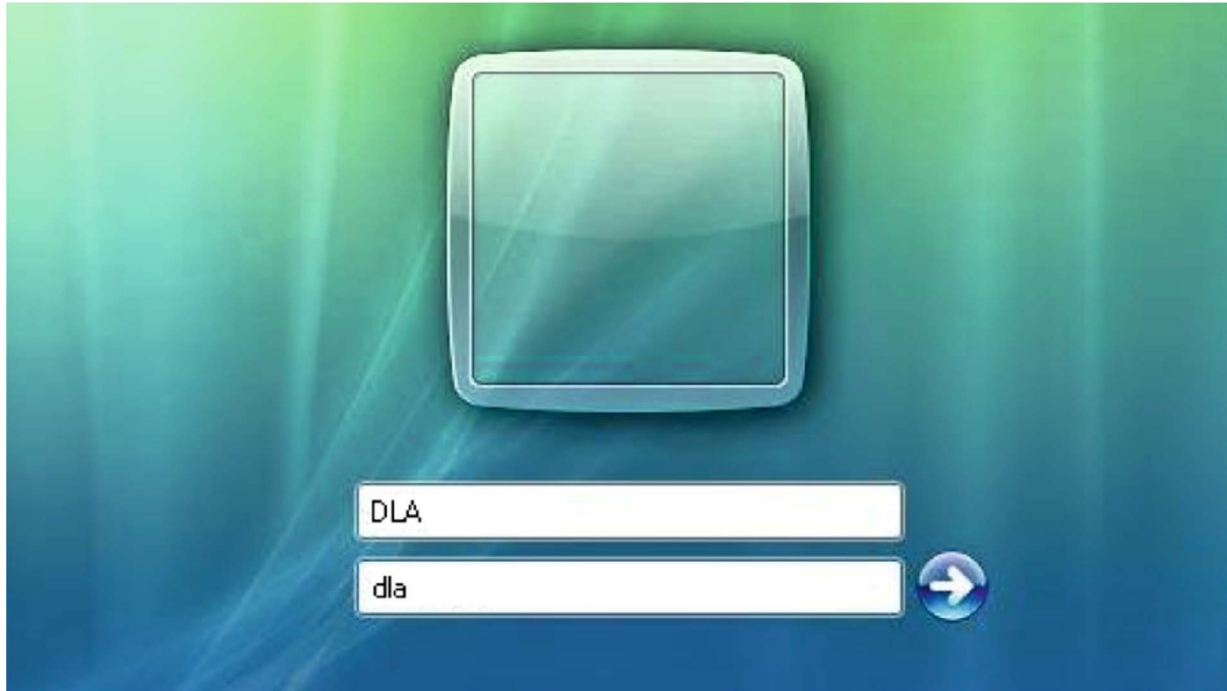

- In the **Log on to** list, if applicable, select the domain or remote computer that you want, and then click **OK**

The remote desktop is displayed in a window on the desktop. The remote computer is locked during this session

- To disconnect the session, click the **Close** button in the session window, and then click **OK** when you are prompted to disconnect the Windows[®] session.

6 ACCESSORIES

The accessories listed here below are described for information purposes only, and are not necessarily included in the packaging. The minimum contents of the packaging include the main hardware, cables and keys. For additional information, please refer to paragraph 1.2.

6.1 CONTROL BOX

Control and command device able to manage:

- Warmup the system
- Open the Shutter and enable laser emission
- Start and Stop the marking process
- Show the marking process status
- Show the system error status

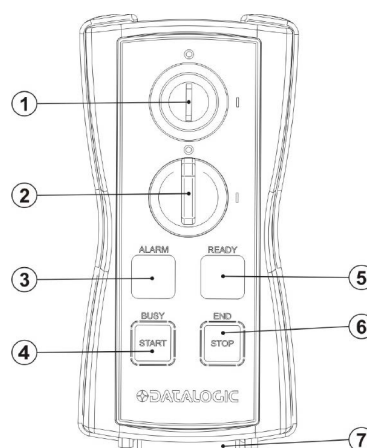
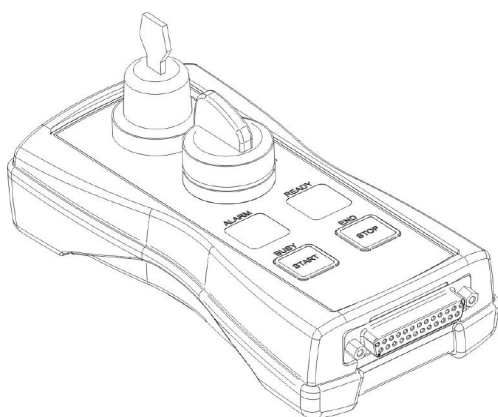

Figure 63: Control Box (Ordering no: 985330031).

1	Key selector
	Selector switch for <i>EXT_KEY</i> control signal
2	Enable selector / <i>ENABLE</i> indicator
	Selector switch for both <i>EXT_ENABLE_A</i> and <i>EXT_ENABLE_B</i> control signals with LED indicator for <i>ENABLE_OUT</i> control signal
3	Alarm indicator
	LED indicator for <i>SYSTEM_ALARM</i> control signal
4	Start button / <i>BUSY</i> indicator
	Pushbutton for <i>START_MARKING</i> control signal with LED indicator for <i>BUSY</i> control signal
5	Stop button / <i>END</i> indicator
	Pushbutton for <i>STOP_MARKING</i> control signal with LED indicator for <i>END</i> control signal
6	<i>READY</i> indicator
	LED indicator for <i>SW_READY</i> control signal
7	External connector
	Connection to Command Box connector

* Refer to Command Box connector (see paragraph 2.4.3) for detailed control signal's description.



WARNING!

If the Control Box is used, the marking system works in **DANGEROUS** condition.

6.2 MARKING ON FLY KIT

The marking on fly kit is available on request. Kit includes: encoder, photocell, cables and plastic reflectors.

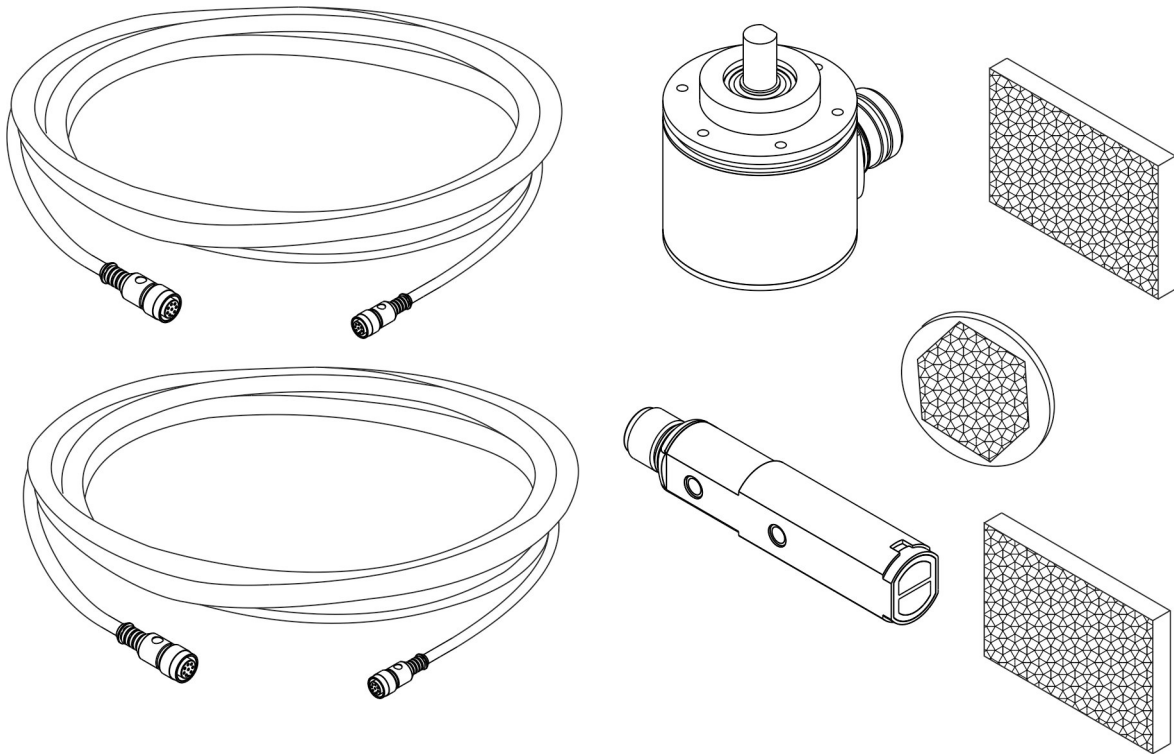

Figure 64: Kit MOF (Ordering no: 985330027).

6.3 CABLE KIT LENGTH PLUS

Cable Kit length plus are available on request.

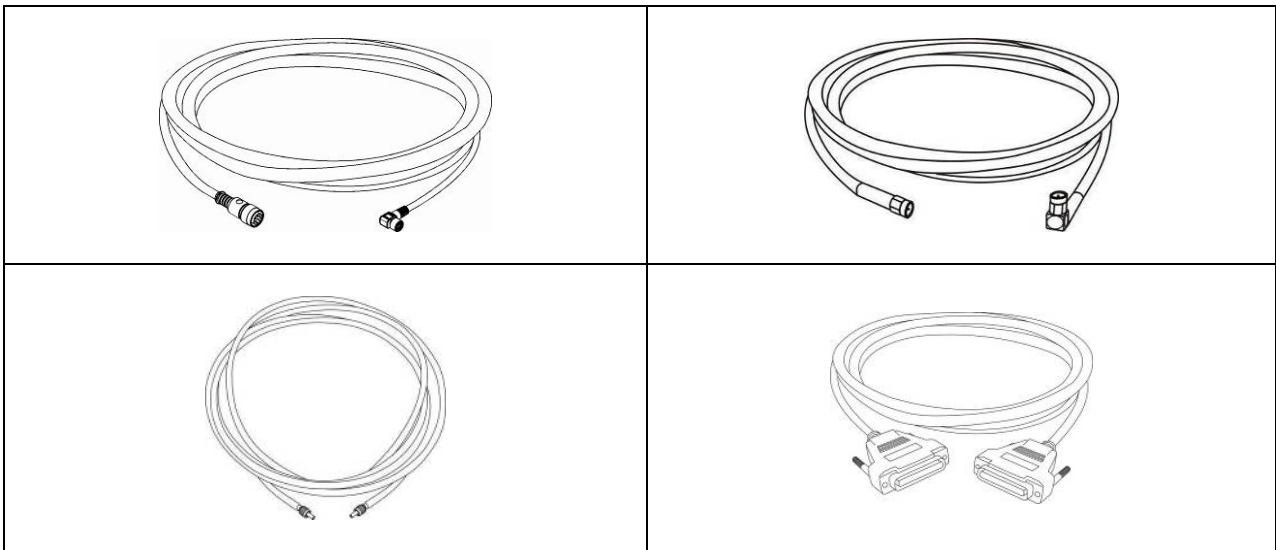

Figure 65: Cable Kit length plus.

6.4 RACK HANDLES

Handles for rack fastening are available on request.

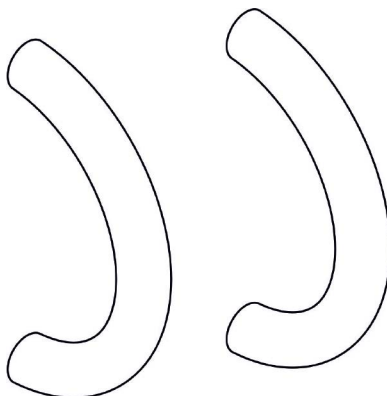

Figure 66: handles rack.

7 TECHNICAL SUPPORT

7.1 SEALS

The marking system has seals in some areas. The seals must not be broken or removed for any reason. The sealed parts may be opened only and exclusively by Datalogic. Breakage of these seals by a customer shall result in immediate cancellation of the warranty on the entire marking system.



WARNING!

If a customer **breaks or removes the seals placed** by the manufacturer on the marking system **the warranty** on the entire marking system will immediately become "***null and void***".



WARNING!

The manufacturer shall not be held liable for any **non-conforming use** of marking system of its manufacture.

It is **forbidden** to operate the marking system before the machine it is intended for, has been **declared in conformance** with statutory Directives.



WARNING!

Access to the internal parts of the control rack is only permitted for **authorized personnel**, who have been trained and instructed on the electrical risks.

Datalogic shall not be held liable for work on electrically charged parts by inadequately trained personnel!



WARNING!

Access to the internal parts of the scan head is only permitted for **authorized personnel**, who have been trained and instructed on the optical risks!

Datalogic shall not be held liable for work on parts by inadequately trained personnel!

7.2 MAINTENANCE

The ordinary maintenance program foresees only simple operations. Some operations consist in a mere “check” of the operating condition.

The maintenance activities must be done in compliance with the law prescriptions regarding the safety rules during the operations.

The following parts/functions have to be controlled:

MAINTENANCE PROGRAM

COMPONENT OR FUNCTION	TYPE OF OPERATION	INTERVALS
F-Theta Scan Lens	Check / Clean	Weekly: wipe gently with a dry cloth (or soaked in high purity isopropyl alcohol) or clean it with air blowing
Rack Air filters	Clean / Replace	Every 3 months (according to the environment and frequency of use)

7.2.1 F-THETA SCAN LENS CLEANING PROCEDURE

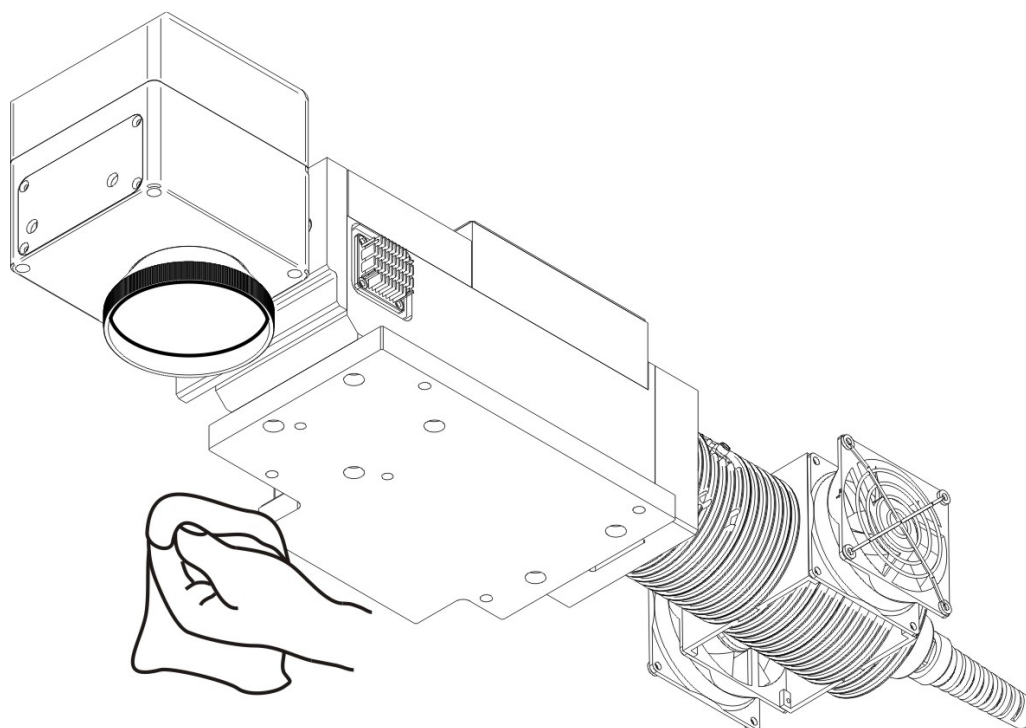

Figure 67: Cleaning F-Theta lens.

WARNING!

Before cleaning the F-Theta scan lens, the marking system **MUST** be in set **SAFE** mode:

- 1- Disable *EXT_ENABLE_A* and *EXT_ENABLE_B*.
- 2- Disable *INTERLOCK_A* and *INTERLOCK_B*.



7.2.2 AIR FILTER CLEANING PROCEDURE

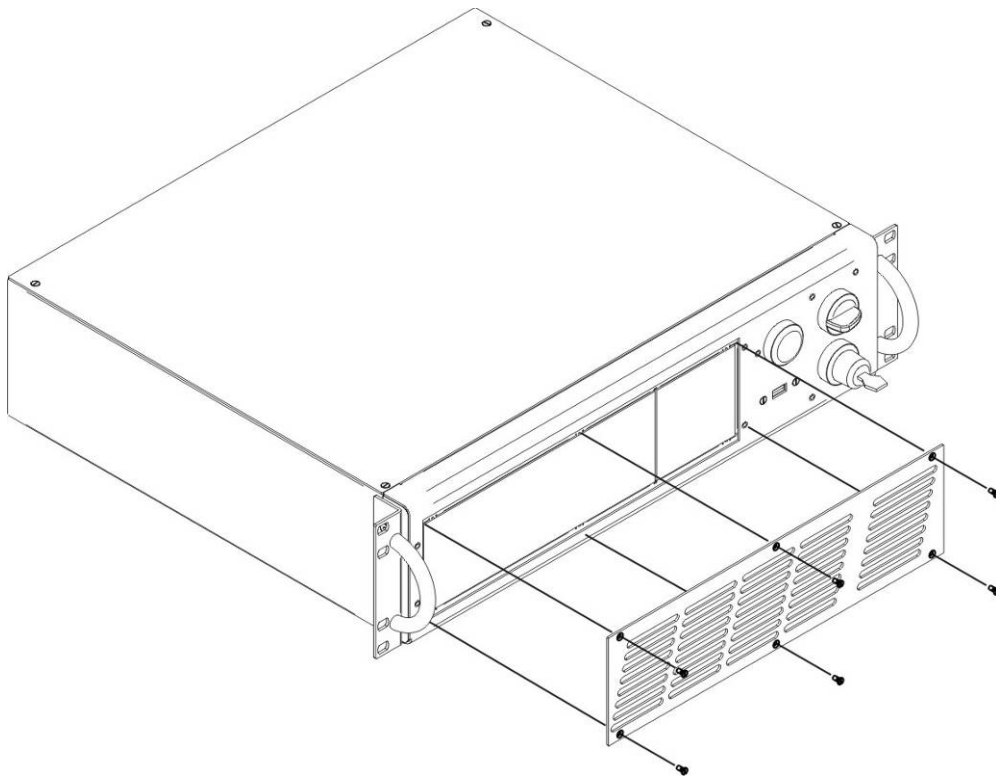

Figure 68: Remove of air filter.



WARNING!

In order to set the marking system in SAFE mode, disconnect AC power cable before starting this operation!

1. Turn off key switch on controller unit
2. Disconnect AC power cable
3. Loosen screws of front panel and remove them
4. Remove filter
5. Clean filter with air blow or with neutral detergent and air-dry it
6. Reinstall the filter and protective cover



WARNING!

DO NOT install wet filter!

7. If filter cannot be cleaned, replace the filter
8. Suitable filters are available as spare parts

7.3 PRODUCT SUPPORT AND CUSTOMER SERVICE

Warranty Information

Datalogic reserves the right to change the information and specification contained in this manual without prior notice.

Product Support

In the unlikely event that the marking system does not function normally and that it requires attention, contact Datalogic for advice on further on-site fault diagnosis and/or module return.

If the marking system is to be returned to Datalogic, ensure that all relevant return documentation is in place before shipment. Details of documentation requirements and copies can be obtained where required from Datalogic.

Pack the marking system in the original packing and include all original accessories and documentation as detailed in the original inventory. It is advised that the correct and original packaging is used to prevent transit damage to the marking system. If part or all of the original packaging is unavailable, please contact Datalogic for replacement items. Please take time to complete all return documentation. This can be obtained from Datalogic and accurate details, diagnosis and comments in the documentation can help reduce turnaround time for module repair at Datalogic.

Customer Service Contacts

Product Support

support-dla-lasermarking@datalogic.com

Tel: +39 051-3147011

Customer Services

service-dla-lasermarking@datalogic.com







Tel: +39 0331-918001

Company Web Site



www.datalogic.com

For further contact information see the Contact Us link at www.datalogic.com or contact your local distributor.

APPENDIX A: LABELS IDENTIFICATION

LABEL	DESCRIPTION									
	Identification label									
	Warning logotype (Laser)									
<p>This device complies with 21 CFR 1040.10 except for deviations pursuant to Laser Notice n°50 date June 24 2007</p> <p>VISIBLE AND INVISIBLE LASER RADIATION AVOID EYE OR SKIN EXPOSURE TO DIRECT OR SCATTERED RADIATION</p> <table border="1"> <thead> <tr> <th>Wavelength</th> <th>Max Power</th> <th>Max Pulse</th> </tr> </thead> <tbody> <tr> <td>350-360nm</td> <td>5 W</td> <td>1mJ / 5ns</td> </tr> <tr> <td>630-670nm</td> <td>1 mW</td> <td>-</td> </tr> </tbody> </table> <p>CLASS 4 LASER PRODUCT IEC60825-1:2014</p>	Wavelength	Max Power	Max Pulse	350-360nm	5 W	1mJ / 5ns	630-670nm	1 mW	-	Laser Label (resonator) ⁵
Wavelength	Max Power	Max Pulse								
350-360nm	5 W	1mJ / 5ns								
630-670nm	1 mW	-								
<p>This device complies with 21 CFR 1040.10 except for deviations pursuant to Laser Notice n°50 date June 24 2007</p> <p>INVISIBLE LASER RADIATION AVOID EYE OR SKIN EXPOSURE TO DIRECT OR SCATTERED RADIATION</p> <table border="1"> <thead> <tr> <th>Wavelength</th> <th>808 nm</th> </tr> </thead> <tbody> <tr> <td>Max Output Power</td> <td>70 W</td> </tr> </tbody> </table> <p>CLASS 4 LASER PRODUCT IEC60825-1:2014</p>	Wavelength	808 nm	Max Output Power	70 W	Laser Label (control rack) ⁵					
Wavelength	808 nm									
Max Output Power	70 W									
<p>AVOID EXPOSURE</p> <p>VISIBLE AND INVISIBLE LASER RADIATION IS EMITTED FROM THIS APERTURE</p>	Aperture Label									
<p>CAUTION</p> <p>VISIBLE AND INVISIBLE CLASS 4 LASER RADIATION WHEN OPEN AVOID EYE OR SKIN EXPOSURE TO DIRECT OR SCATTERED RADIATION</p>	Label for non-interlock protective housing									
	Caution, possibility of electric shock									
	General Warning									
	USB plug									
<p>MAC Address</p> <p>00:07:BE:00:7C:44</p> 	MAC Address									

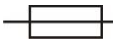
⁵ Maximum output of laser radiation as per definition 3.55 of IEC60825-1 considering single fault conditions.

 2xT10A	Rack Fuses
 2xF2A	Resonator Fuses
0 - I	KEY/ENABLE Positions
COMMAND BOX	Command Box connector
AXES (I/O)	Control Axes connector
INTERLOCK	Interlock Connector
INTERLOCK OUT	Interlock OUT Connector
LAN	LAN connector
RS232	RS232 connector
VGA	VGA connector
PHOT	Photocell connector
ENC	Encoder connector
RES	Resonator connector
MDR	Scan Head connector
RF	Radio frequency connector
FAN	Fan connector

POSITIONING OF EXTERNAL LABELS

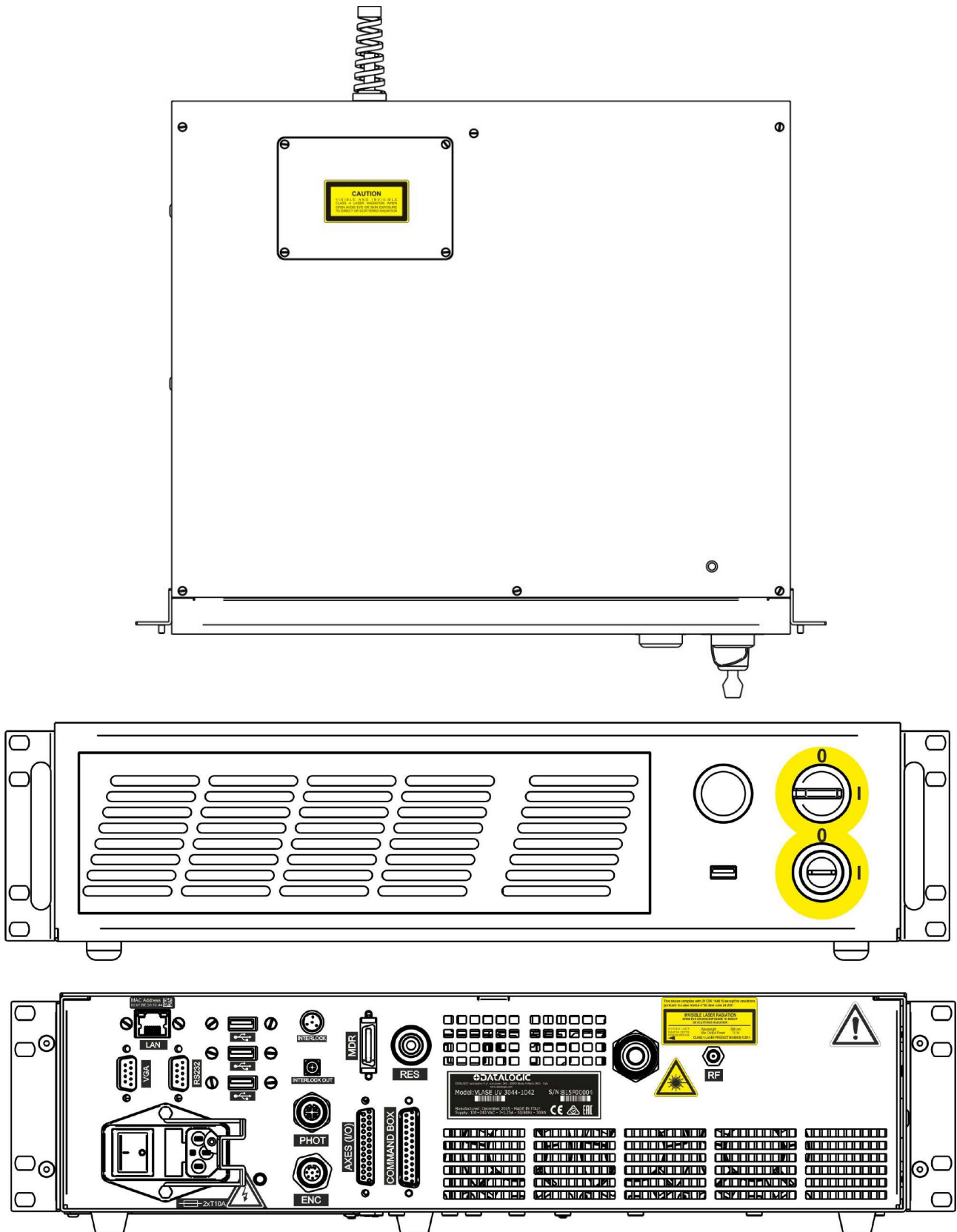

Figure 69: Positioning of external labels.

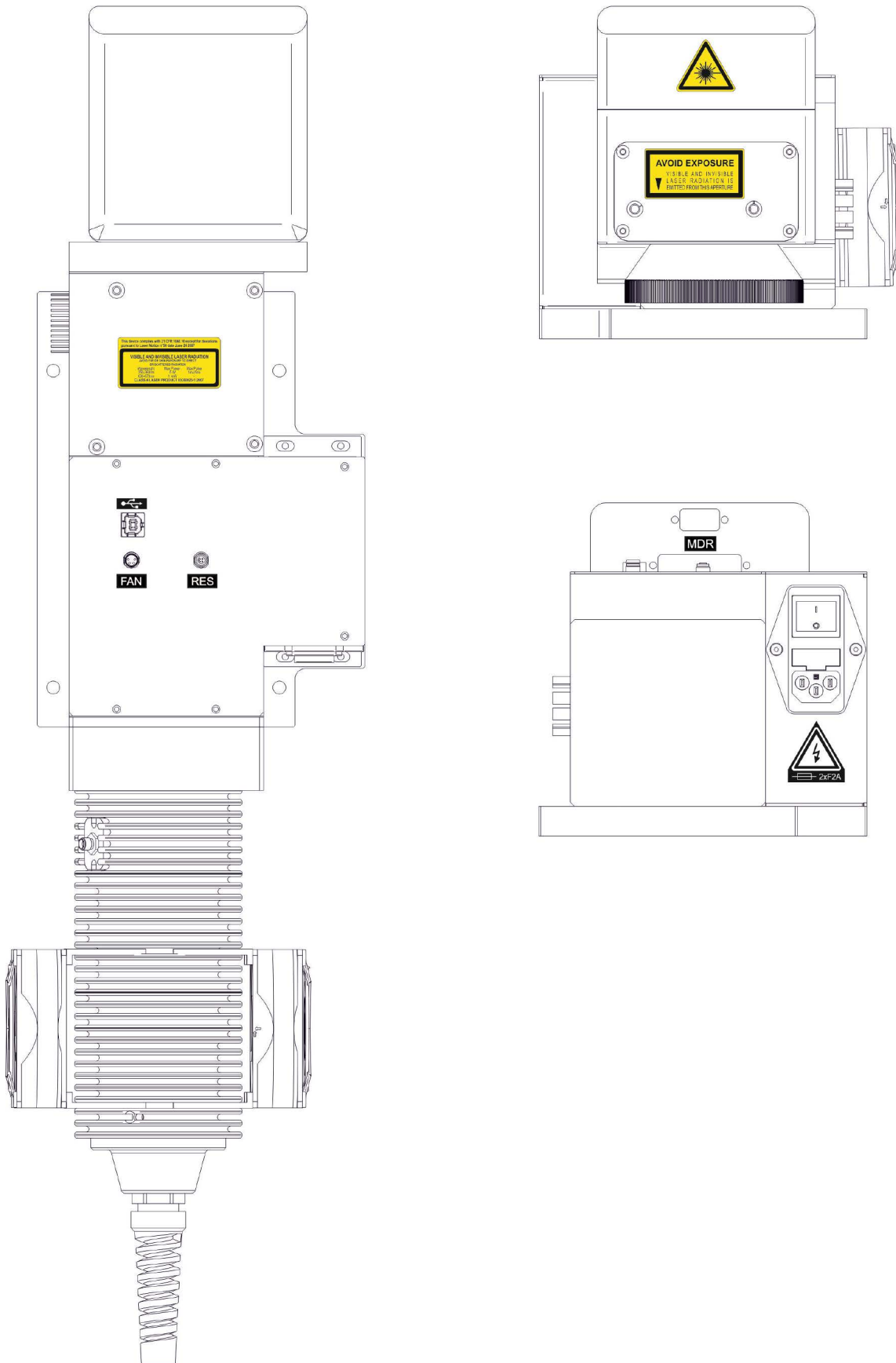

Figure 70: Positioning of external labels (resonator).

APPENDIX B: STANDARDS

LASER STANDARDS

The marking system is designed to comply with the applicable sections of these laser standards:

EU : EN60825-1

USA : 21 CFR 1040.10

The marking system is classified as Class 4 Laser Product.

Datalogic, as manufacturer of marking system, provides a laser which is NOT intended for immediate use, but it must be connected, by others, to other devices which have the final aim of creating a laser processing system.

The final system manufacturer MUST ensure the safety of the laser processing machine according to its standards including the risk-analysis, implementation of safety measures, certification and testing of safety measures and the production of adequate information for use of the machine.

Datalogic is available for providing to the system integrator/OEM all the information in its possession to help in complying with applicable standards.

CE COMPLIANCE

CE marking states the compliance of the product with essential requirements listed in the applicable European directive.

Since the directives and applicable standards are subject to continuous updates, and since Datalogic promptly adopts these updates, therefore the EU declaration of conformity is a living document.

The EU declaration of conformity is available for competent authorities and customers by Datalogic commercial reference contacts.

Since 20th April 2016 the main European directives applicable to Datalogic products require to include an adequate analysis and assessment of the risk(s). This evaluation was carried out in relation to the applicable points of the standards listed in the Declaration of Conformity.

Datalogic products are mainly designed for integration purposes, into more complex systems. For this reason it is under the responsibility of the system integrator to do a new risk assessment regarding the final installation.



WARNING!

This is a Class A, Group 2 product according EN55011. In a Class B environment this product may cause radio interference in which case the user may be required to take adequate measures.

FCC COMPLIANCE

Modifications or changes to this marking system without the expressed written approval of Datalogic could void the authority to use the system.

This system complies with PART 15 of the FCC Rules. Operation is subject to the following two conditions: (1) This system may not cause harmful interference, and (2) this system must accept any interference received, including interference which may cause undesired operation.

This marking system has been tested and found to comply with the limits for a Class A digital device, pursuant to part 15 of the FCC Rules. These limits are designed to provide reasonable protection against harmful interference when the system is operated in a commercial environment. This marking system generates, uses, and can radiate radio frequency energy and, if not installed and used in accordance with the instruction manual, may cause harmful interference to radio communications. Operation of this marking system in a residential area is likely to cause harmful interference in which case the user will be required to correct the interference at his own expense.

APPENDIX C: SAFETY CONSIDERATION ACCORDING TO EN ISO 13489-1:2008

PERFORMANCE LEVEL (PL)

The PL is specified in EN-ISO13849-1. The risk analysis will lead to a PLr (Performance Level required) for a safety function based on the following graph:

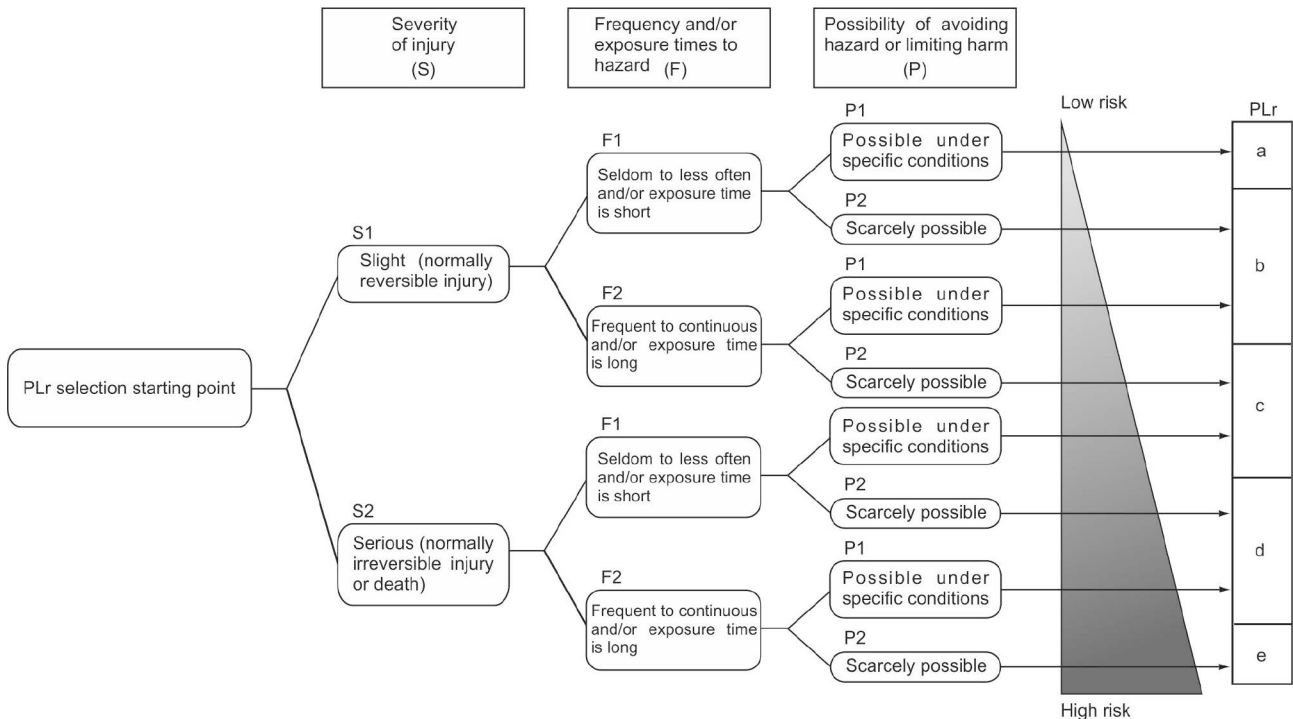

Figure 71: Determining the required Performance Level (PLr).

APPLICATION EXAMPLE

WARNING!

This example relate only to the features introduced in Vlase™ to assist in the risk reduction from the laser radiation. Any other risks (mechanical, electrical, etc.) must always be evaluated and must be taken appropriate risk reduction measures where necessary.

The Machinery Directive and EN 13849-1 are NOT applicable to the product Vlase™.

The target safety integrity or performance level (e.g. PLd according to ISO13849-1) shall be determined by the machine integrator, taking into account the machinery directive, the harmonized standards and any sector-specific standard that may apply.



WARNING!

This example is based on the parameters indicated on paragraph "Safety functions of Vlase™".



EXAMPLE AUTOMATIC PRODUCTION LINE

In this case the Protective Housing may have a guard capable of being opened or removed typically only for service operation (frequency: seldom or occasional):

- Guard opening should only be possible with the aid of a tool.
- Guard safety switch is connected as input of a safety logic and Vlase™ interlock system as output/input of that safety logic.
- Warning label for access panel according EN60825-1 is provided.



Since the frequency is LOW (F1) and the removal of the guard is intentional, the MINIMUM REQUIREMENT as per IEC13849-1 is PLc.

Target: PLr = c

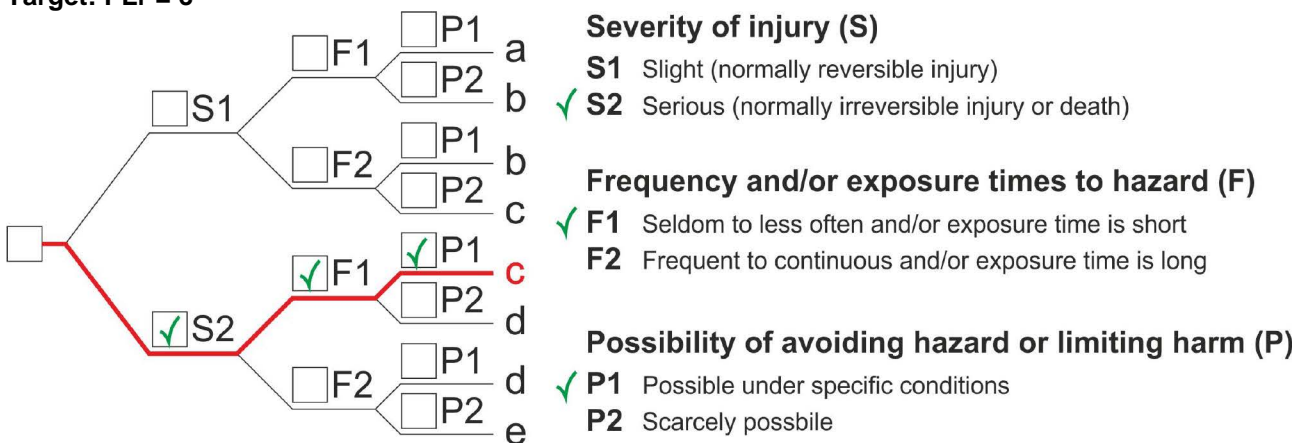

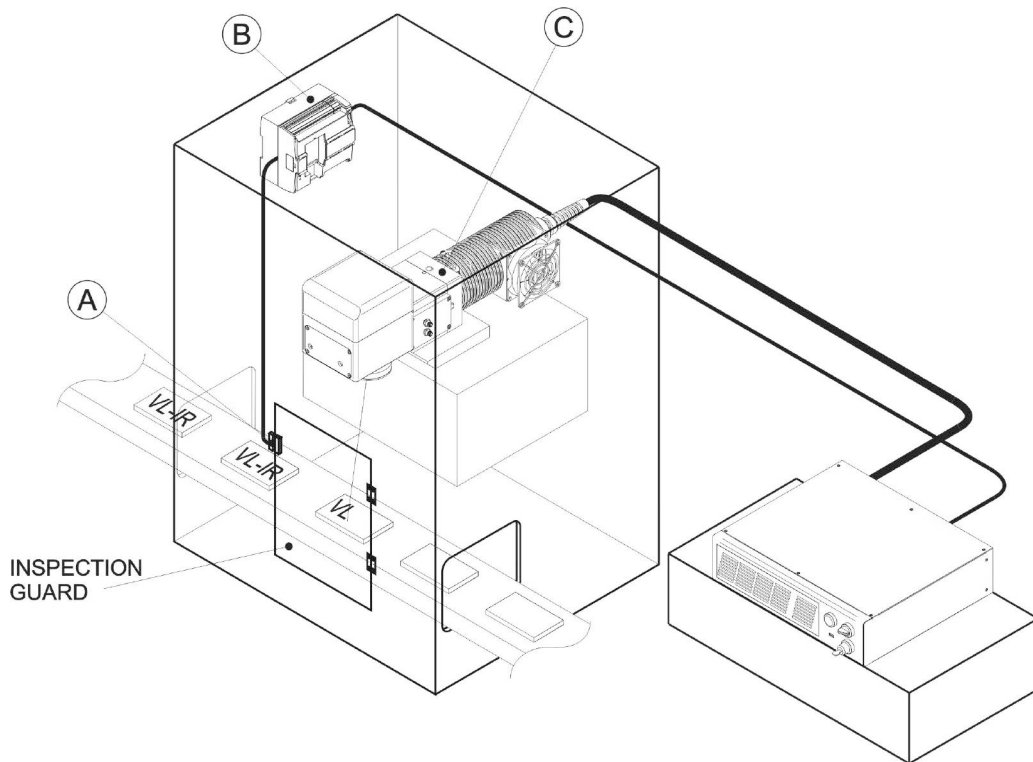

BLOCK DIAGRAM

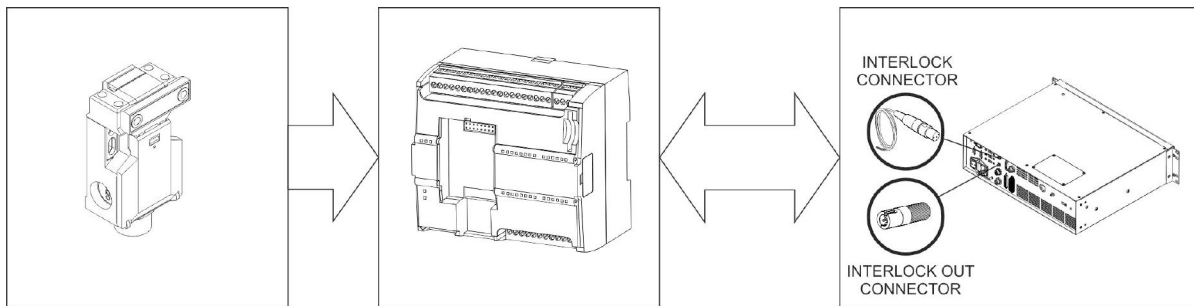

A: SAFETY SWITCH

B: SAFETY LOGIC

C: VLASE

SAFETY LOGIC TO VLASE™ DETAILS FOR AUTOMATIC PRODUCTION LINE

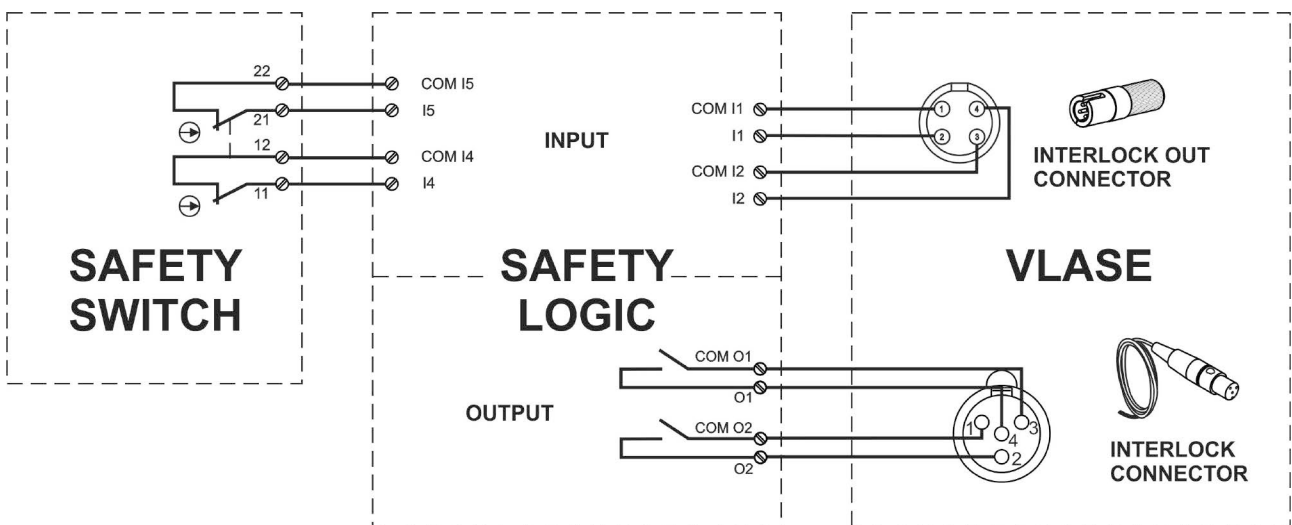

PLC SAFETY DIAGRAM

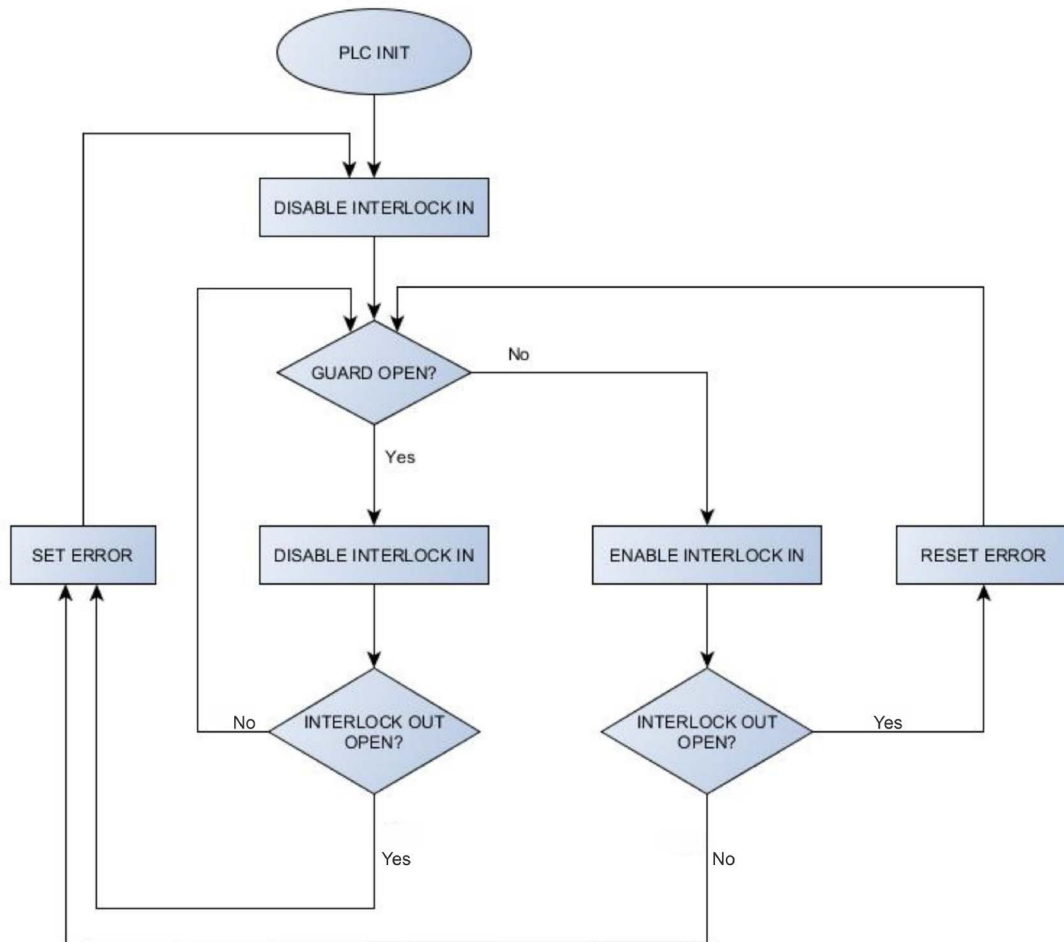

INTERLOCK_A	INTERLOCK_B	INT_OUT_A	INT_OUT_B	CONDITION
OPEN	OPEN	CLOSED	CLOSED	SAFE
CLOSED	OPEN	CLOSED	OPEN	DANGEROUS
OPEN	CLOSED	OPEN	CLOSED	DANGEROUS
CLOSED	CLOSED	OPEN	OPEN	DANGEROUS

True table in normal condition.

CHARACTERISTICS OF COMPONENTS

DOOR SWITCH: SAFETY SWITCH, designed in compliance with the standard currently in effect IEC60947, EN292, EN60204, EN1088. Two redundant contacts. IP67. B10d=2000000.

SAFETY LOGIC: main component SAFETY PLC min. PLd according EN13849-1. Output type relays, min 10mA. To be installed in an IP54 enclosure.

CONCLUSIONS

Because MTTFd is greater than 100 years, Category is 3, DC max achievable is 99% then the PLr=c is satisfied.

SAFETY FUNCTIONS OF VLASE™

Vlase™ provides inputs, outputs and actuators to implement the following safety functions:

- SF.1 ENABLE (e.g. no IR laser output if "EXT_ENABLE_A" or "EXT_ENABLE_B" are disabled, where "disabled" means contacts open)
- SF.2 INTERLOCK (e.g. no IR laser output if "INTERLOCK_A" or "INTERLOCK_B" are disabled, where "disabled" means contacts open)

These functions has been evaluated according to UNI EN ISO 13849-1. The results are:

- SF.1:
 - Category: B
 - MTTFd <10 years
 - DC: none according category
- SF.2:
 - Category: 3
 - MTTFd = 4496 years
 - DC: feedbacks are provided. The determination of the diagnostic coverage (DC%) is then assigned to the integrator of the system depending on realized supervision system.
 - Response time: 10ms

APPENDIX D: NOTE ABOUT LASER

LASER SAFETY

The following information is provided in compliance with regulations set by International Authorities, and it refers to the correct use of marking system.

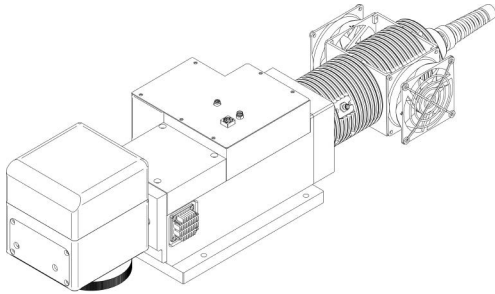

WARNING!

It is crucial that you protect yourself against beams of reflected or direct light as they cause permanent damage to your skin.

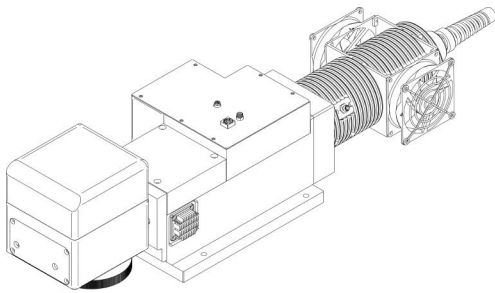

WARNING!

Staring directly at a laser beam may cause irreversible damage to your eyes.

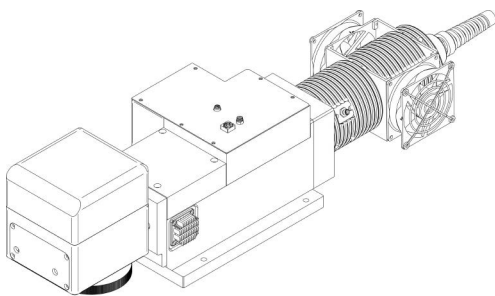

WARNING!

Wear safety goggles while using the system!



NOTE:

BEFORE INSTALLING AND USING THE LASER, READ CAREFULLY THE APPENDIX CONCERNING LASER SAFETY.

LASER RADIATION

Laser radiation is an electromagnetic emission with a micrometric wavelength which ranges from the long infrared (CO₂ Laser), close infrared (Nd Laser: Yag, Nd: YVO₄), visible (He Laser: Ne or Argon) and ultraviolet (excimer laser).

It should be considered non-ionizing Radiation. In Vlase™ marking system, the emission of a crystal bar is stimulated by “optical pumping” generated by a Diode Laser. The continuous reflection of Photons, between a front mirror and rear mirror, creates a positive reaction so that their number continues to increase, until reaching the concentration necessary to produce a beam which projects from the semi-reflecting front mirror. The radiation (which we can imagine as a “Beam of invisible light”) is then Collimated and Focalized with Lenses at a point where the intensity becomes high enough to be able to react with various materials producing an alteration in them due to thermal effect.

The radiations of Vlase™ marking system are visible and invisible and the Eye receives it almost in its entirety without using the natural defense provided by pupil reflex! Added to this is the fact that it is generally very intense, with the result that it can be very harmful to the eye and present vision problems.



WARNING!

Directly viewing a laser beam **can cause irreversible damage** to vision.

To prevent permanent damage to vision, a few precautions must be taken.

All individuals who may be exposed to dangerous levels of laser radiation, must know that the laser is active and wear protective goggles if necessary.

Due to its high power, the laser integrated in the Datalogic system provokes reflected laser light from flat surfaces. Reflected light is potentially dangerous for the eyes and skin. Electromagnetic emission with a micrometric wave length is placed in long infrared, and is therefore invisible, thus it is not clear where reflected beams are aimed.



WARNING!

It is indispensable to protect yourself from reflected light beams, because they can be sufficiently intense to create permanent injury to the eyes or skin.

In addition to possible injury to the eyes or skin, direct laser emission can cause flammable materials to burn like organic solvents (alcohol, acetone) or gasoline and cause fabric and clothing to burn.



WARNING!

This marking system is classified as **Class 4**. Class 4 includes lasers which can produce risks, not only from **direct** or **reflected** radiation, but also from **scattered** radiation! The laser sources may be a significant risk for the skin and risk of burning flammable materials.

ABSORPTION OF LASER RADIATION

Human skin absorbs electromagnetic radiation in different ways depending on the wave length of the radiation. Both the eye and skin have a “predisposition” for accepting certain wave lengths, and are more unresponsive to absorbing others. In the specific case of the Eye, the Cornea and Crystalline lens let all the wave lengths from 400 to 1400 nm pass and reach the Retina, even with various attenuations. They include the range from visible light to IRA infrared. Thus Nd:YVO₄ laser radiation (355 nm wavelength) is included in this range and **leads to direct Retina exposure!**

In terms of the Skin, the “biological window” has different absorption percentages but is not dissimilar in terms of wave length. The maximum exposure values for Skin are much different compared to those tolerated by the Eye.

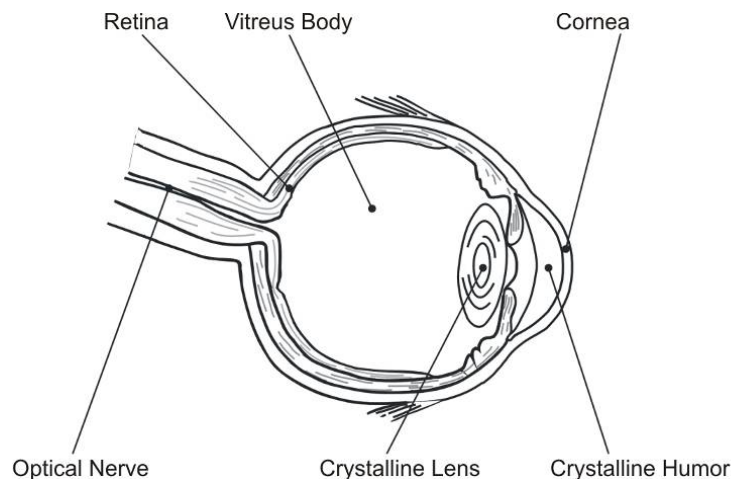

Figure 72: Eyeball section.

In terms of the damage mechanism that absorbed radiation can cause, it also depends on the wave length. Short lengths (ultraviolet: UV-C 180-280nm; UV-B 280-315 nm, UV-A 315-400 nm) generally cause photo-chemical effects:

- cataract, or opacification of the crystalline lens
- melanic coloring, or reddening of the skin

Greater wavelengths (infrared: IR-A 780-1400 nm; IR-B 1400 3000 nm; IR-C 3000-10^{E6} nm) generally cause thermal effects:

- detachment or photocoagulation of the retina
- burning of the skin

The degree of injury obviously depends on the **amount of absorbed radiation** and the **instantaneous power** of the radiation source.

CLASSIFICATION AND DANGER LEVEL

Regulations have established different classes of Laser danger based on the ability to injure people, from Laser Class 1 (basically safe in all conditions) to Laser Class 4 dangerous in various conditions.

Lasers which can produce risks, not only for direct or reflected radiation, but also for scattered radiation belong to Class 4. These Laser sources can also have a significant risk for the Skin and fire risk for flammable material. For these reasons, the User must put into effect all measures aimed at containing the radiation to make sure that it is terminated at the end of its useful path. The operator must also be informed of the risks from exposure to Laser radiation and must wear specific I.P.D. (individual protection devices) including goggles that protect against radiation and are certified as suitable for this use.



WARNING!

The Vlase™ marking system contains a **Class 4 invisible** laser source.

RADIATION VIEWING CONDITIONS

The laser output by the resonator is to be considered as a highly collimated and intense monochromatic light source. Due to these characteristics it can be seen as a “point source” of high luminosity. This means that its image is then focalized on the Retina in a very small spot with a dangerously high power density! If the beam becomes divergent and scatters to a non-reflecting screen, then there is an “extended vision” of the image, with a decisively less dangerous power density. So there are different types of radiation viewing based on the access to the radiation and consequently different degrees of dangerousness.

DIRECT VIEWING OF THE LASER BEAM

This type of viewing is the most dangerous and can occur at the outlet of the laser aperture after having removed the lens. It is to be avoided at all costs! No protective goggles represent a valid means against direct viewing of the beam.

DIRECT VIEWING OF THE BEAM AFTER MIRROR REFLECTION

This may occur by directing the beam on a reflecting surface.
Viewing of a mirror reflected beam from a flat surface is very dangerous and equal to direct viewing.

DIRECT VIEWING OF THE BEAM OUTPUT BY AN OPTICAL FIBER

This happens if an Optical Fiber disconnects from the resonator. Viewing of the beam is dangerous up to a significant distance. Filters and Goggles do not ensure safety.

DIRECT VIEWING OF THE BEAM AFTER FOCUSING

This occurs if the laser beam is not extinguished with an opportune absorber at the end of its useful path. Looking at the beam is dangerous up to a considerable distance. Filters and goggles can ensure safety for brief exposure, as long as they are the right size and certified.

SCATTERED VIEWING OF THE BEAM AFTER FOCUSING

This is the most frequent viewing, but opportune Filters and Goggles can ensure safety, even for prolonged exposure.
The Nominal Ocular Hazard Distance (N.O.H.D.) for Vlase™ are showed in the next paragraph.



WARNING!

Always use goggles with conformity certificate.

Remember that **no goggles can provide prolonged protection from direct or mirror-reflected radiation!**

N.O.H.D. DETERMINATION AND O.D. OF PROTECTION GOGGLES

In order to determinate the characteristics of the protection goggles, it is essential to determine the characteristics of the radiation, knowing its optical path, the dimensions of the beam and its divergence.

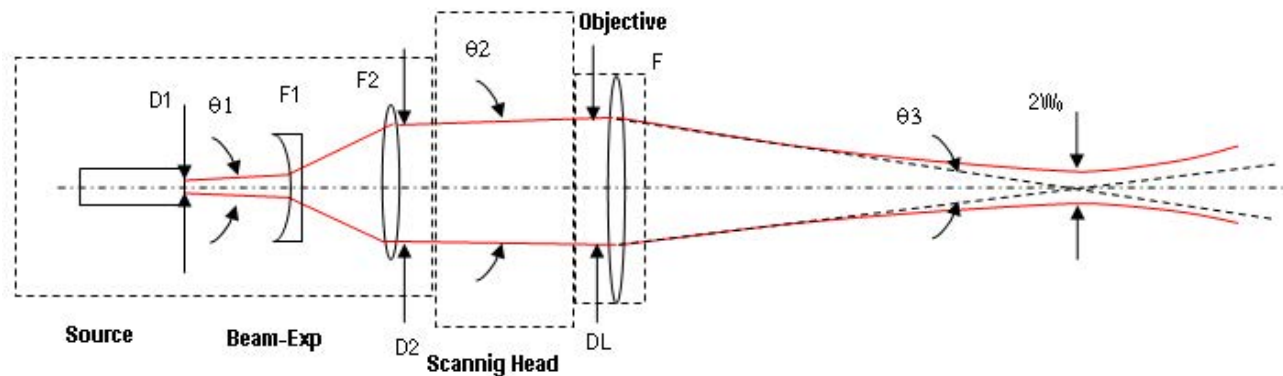

In particular, it is very important to know the real divergence of the beam in output from the objective (F-Theta).

With all these optical data it is possible to calculations of the Nominal Ocular Hazard Distance (N.O.H.D.) and of the optical density (O.D.) requested to the protection filters of the laser radiation.

Calculations have been done following the CEI EN 60825-1 (2014) Normative regarding nominal distance and optical risk in the worst condition and in case of accident exposure of 10 seconds for direct radiation and 100 seconds for diffused radiation.

Wavelength	355 nm
Application type	Marking
Emission type	Q-Switched
Observation type	Direct radiation
Pulse energy	Vlase™ UV 3039-TFS2: 100 μ J @ 30 kHz
Pulse duration	Vlase™ UV 3039-TFS2: 8 ns
Beam Diameter at 9X Beam Expander Output (1/e ²)	Vlase™ UV 3039-TFS2: 6.0 mm
Beam divergence on the lens	Vlase™ UV 3039-TFS2: 0.6 mrad
Focal of the F-Theta lens	160 mm
Real divergence after the lens	Vlase™ UV 3039-TFS2: 37,5 mrad
Exposure time	10 s

ACCIDENTAL CONDITION OF VISION OF THE DIRECT REFLECTED RADIATION

Assuming a direct exposition of 10 seconds at a nominal distance of 0,5 m (worst case) is possible to calculate the suitable optical density for safety goggles.

The O.D. (Optical Density) in last column assure to reduce laser radiation below max acceptable level:

O.D.= $\log (H/EMP)$ where EMP is the Maximum Permissible Exposure and H is the radiant exposure.

Source	N.O.H.D. (Nominal Ocular Hazard Distance)	O.D. (Optical Density)
Vlase™ UV	21 m	> 2.1

SCALE INDEX OF THE PROTECTION GOGGLES FILTER

The scale index L of the filters indicates the stability to the radiation, that means the ability of the filter to maintain its characteristics unchanged. This stability is certified by the producer according to the EN 207 with tests conducted for 10 seconds or 100 pulses.

It is then necessary to verify that the scale index of the adopted filter is stable for this period and foreseen an adequate over dimensioned in order to make sure that it could last longer than the accidental exposure period.

In case of exposure at 0,5 m for 10 seconds the suggested optical density for safety goggles is CLASS L4.

EYES AND SKIN RISKS

If exposed to intense Laser radiation, even of a short duration, or a less intense but longer lasting duration, both the Cornea and the Retina can burn and be damaged irreparably forever. This consequence is completely realistic in the event of direct viewing of a Class 4 Laser beam.

If subject to direct focalized radiation, even the skin can burn.

In addition, it is necessary to bear in mind that a collateral ultraviolet radiation may exist with the main radiation: long exposure may cause skin cancer.

GENERAL SAFETY REGULATIONS

The User must comply with the regulations and work in the best possible safety conditions to prevent decreasing the degree of marking system safety. Therefore it is necessary to develop a Standard Operating Procedure (S.O.P.) related to maneuvers to effect for turning on and off the marking system. This procedure, which shall be prepared around the time of installation, shall serve as a reference for the Operator and shall be written in his/her language.

Training is essential and must include:

- Familiarization with system operating procedures.
- Knowledge of the biological effects of radiation on the Eyes and Skin.
- Understanding of the necessity for Individual Protection Devices (I.P.D.)

COLLATERAL RISKS

If the intended use of the marking system changed, for example for material processing applications, collateral risks may arise represented by the production of fumes and vapors which may be irritating or toxic, if not removed and adequately filtered before being released into the air again.



WARNING!

It is advisable **not to change the intended use** without previously contacting the Manufacturer.

An additional risk may be represented by fire caused by processing materials other than those the marking system is designed for.



WARNING!

When processing **flammable material**, since there is a **fire danger**, it is indispensable to follow the instructions provided by the manufacturer when the system is commissioned.



WARNING!

Do not subject **materials other** than those the system was designed for to radiation.

The most serious collateral risk associated with laser marking system, which may be fatal, is electricity. This may occur when the manufacturer's warning and procedures are not followed. Unauthorized and untrained personnel must never do any work on the electrical part. The safety devices must never be removed and their operation must be periodically checked.



WARNING!

Do not work on the electrical part if you are not trained to do so. **Do not remove protection devices.**

For example, during the intended use of the marking system, if a material being processed undergoes alterations and produces irritating and/or toxic fumes, it may be necessary to remove the fumes from processing before releasing them into the air.

An additional risk may be represented by fire caused by processing materials other than those the system was designed for.



WARNING!

Do not subject **materials other** than those the system was designed for to radiation.

APPENDIX E: SOFTWARE UPGRADE

This document describes how to update software version:

1. Close the Lighter and Laser Engine (Click on **QUIT**)

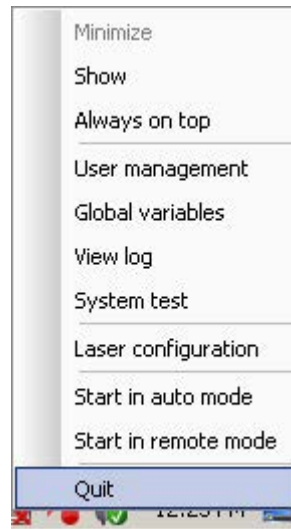

2. Do Lighter **UNINSTALL**: you cannot run the new installer before having removed the old software version

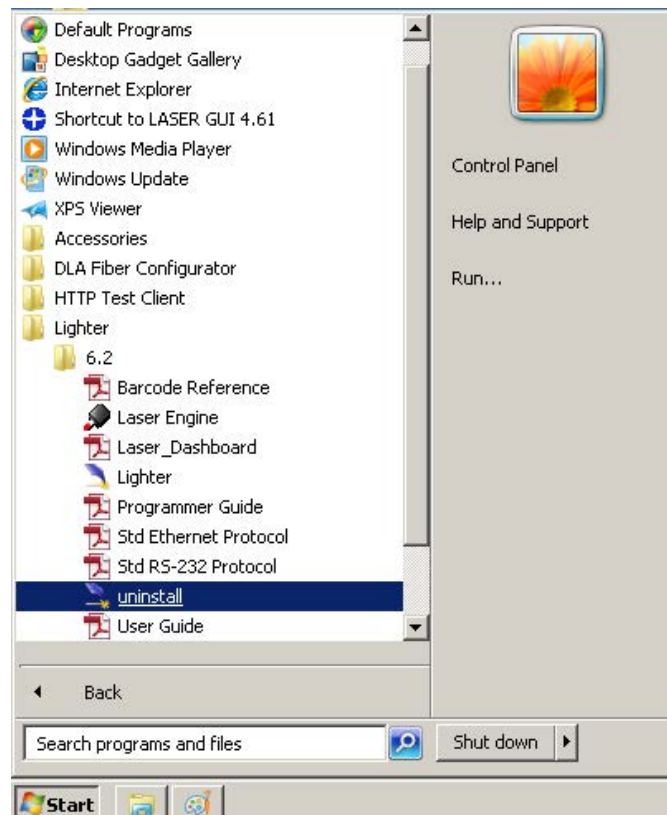

3. Wait the end of uninstall procedure.
4. Run new Lighter installer from an external device (USB dongle).
5. Wait until installation procedure is completed.
6. Depending on whether the Lighter update includes any control board updates, the following screen may appear:

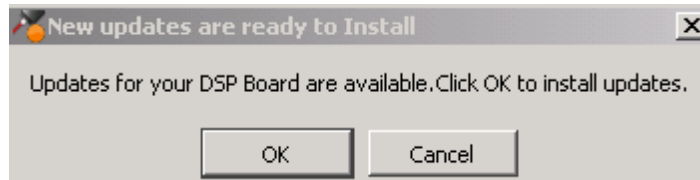

- Procedure with control board update:
 - press **OK** to execute control board update
 - upon completion, a window informs user that data is automatically saved in the system

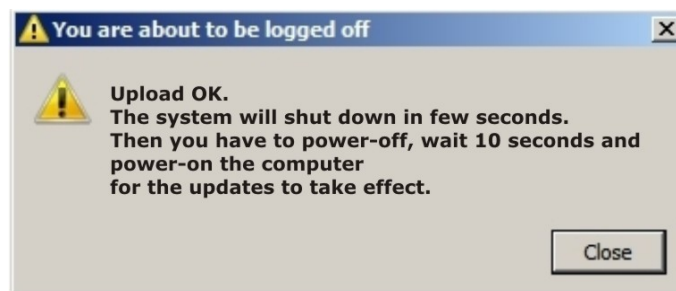

- system will be shut down automatically within the next 10 seconds



WARNING!

DO NOT restart the system or turn off the system!

- wait until system shuts down automatically (black screen)
- power off the system to complete installation

- Procedure without control board update:
 - a window informs user that data is automatically saved in the system



- system will be restarted automatically within the next 10 seconds



WARNING!

DO NOT restart the system or turn off the system!

- wait until system is restarted automatically

APPENDIX F: RECOVER THE SYSTEM USING USB RECOVERY DISK

The marking system is provided with a **USB recovery disk** able to restore the system to the factory settings. The **USB recovery disk** should be used if the *Operating System is corrupted* or disks are *corrupted*.



WARNING!

All the existing data in the system will be overwritten. All existing data will be lost!

The recovery procedure requires the **USB recovery disk** which is included in the standard equipment.

Procedure:

- Turn OFF the system
- Insert the USB recovery disk provided with the system in the USB port
- Turn ON the system and press **ESC** key to enter BIOS menu
- Go to BOOT menu, select **Hard Drive BBS Priorities** and press **ENTER** key
- Select **Boot Option #1** and press **ENTER** key
- Select the USB disk from the list and press **ENTER** key
- Press **F4** key
- Select **YES** and press **ENTER**
- The system will restart and Clonezilla live will boot from the USB disk

- o Select Datalogic Recovery Disk procedure

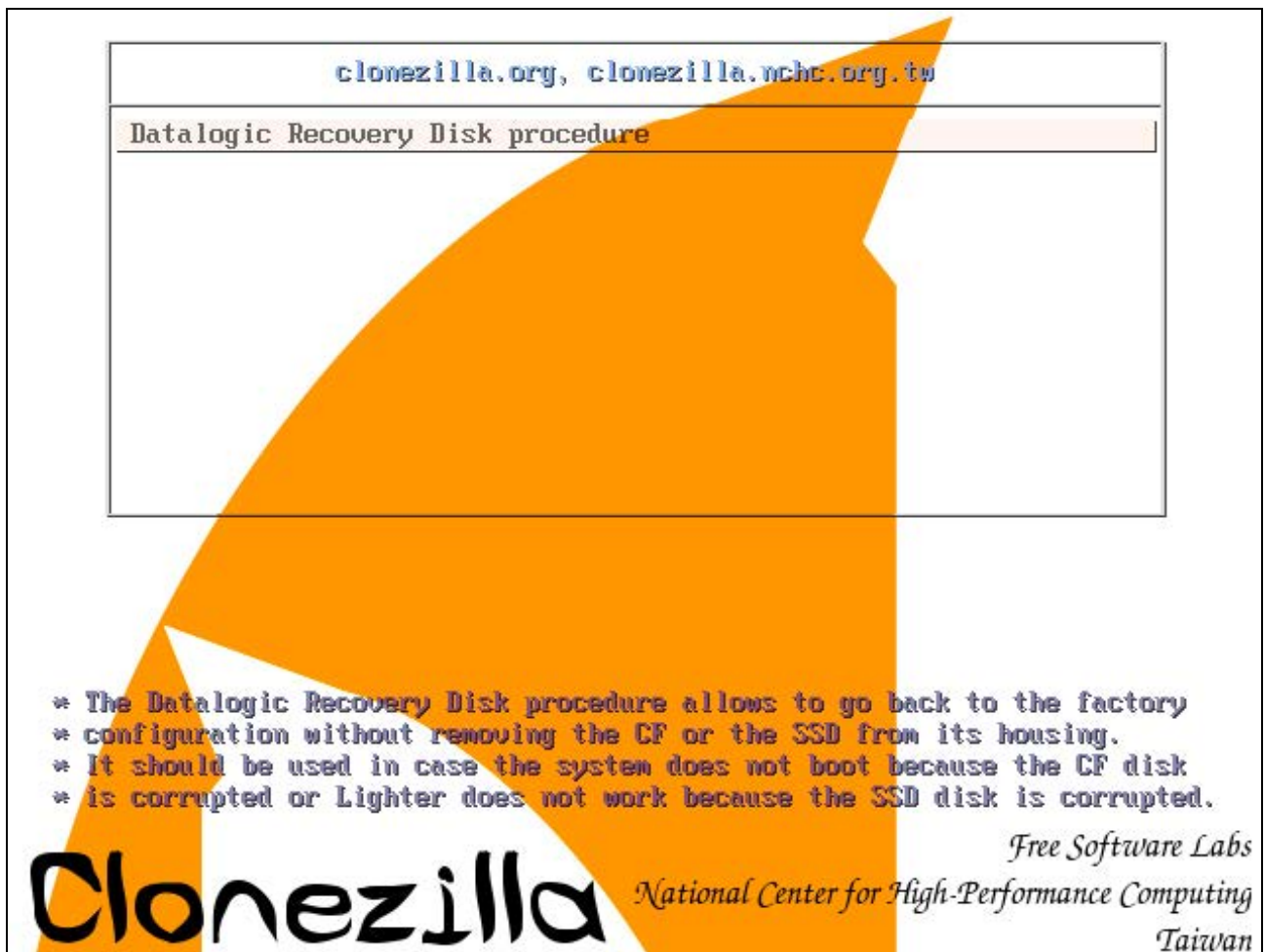

- o Press **ENTER** key to continue
- o Choose **RESTORE_DISK_C_PCM3365** to restore *disk C:* and press **ENTER** key

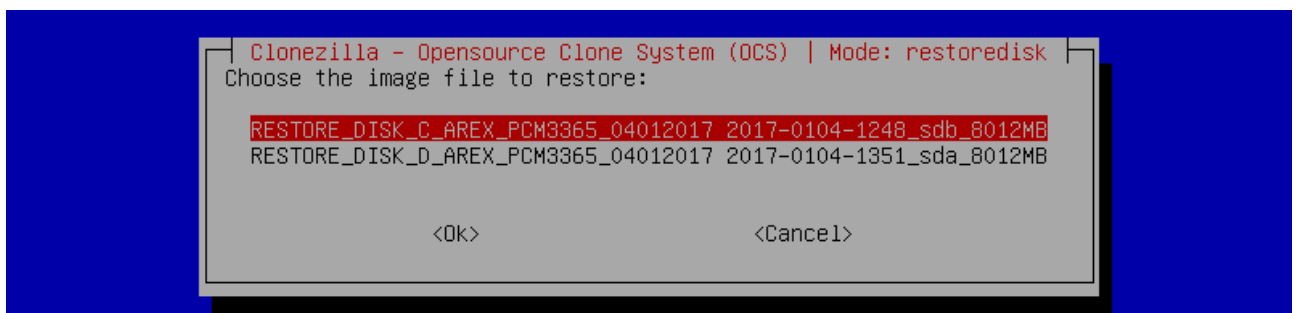

- o In the next screen, choose **sdb** as target disk and press **ENTER** key

- Wait for the end of the procedure (about 10 minutes):

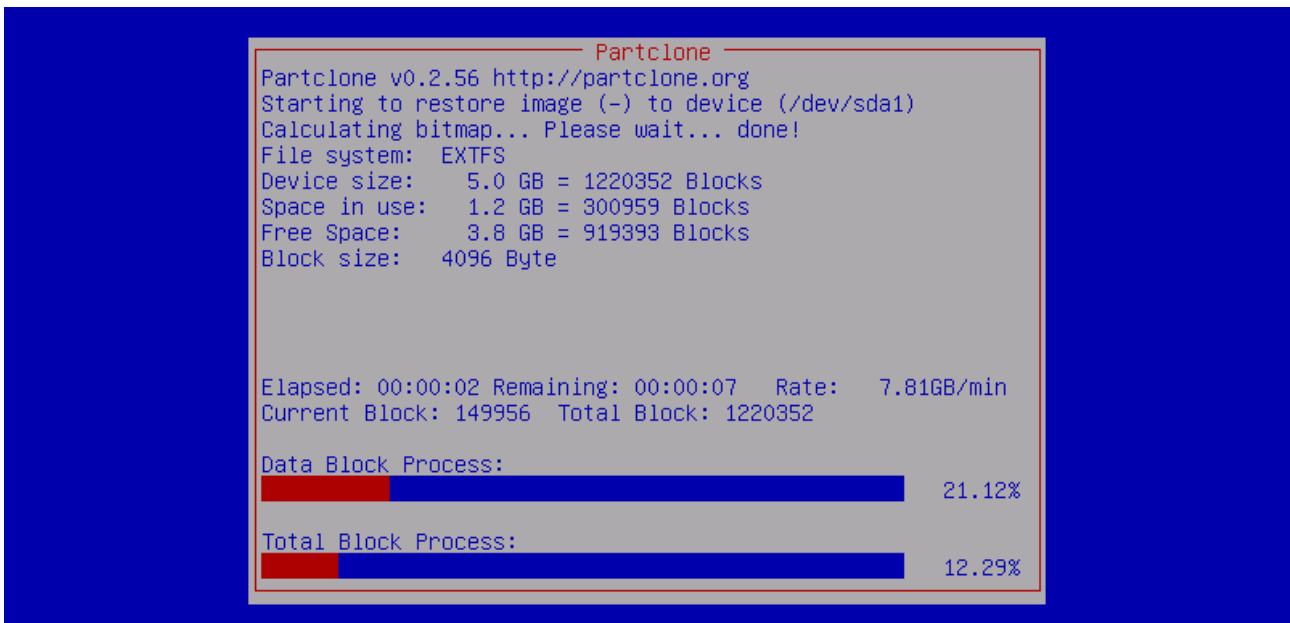

- Select **Enter command line prompt** and press **ENTER** key

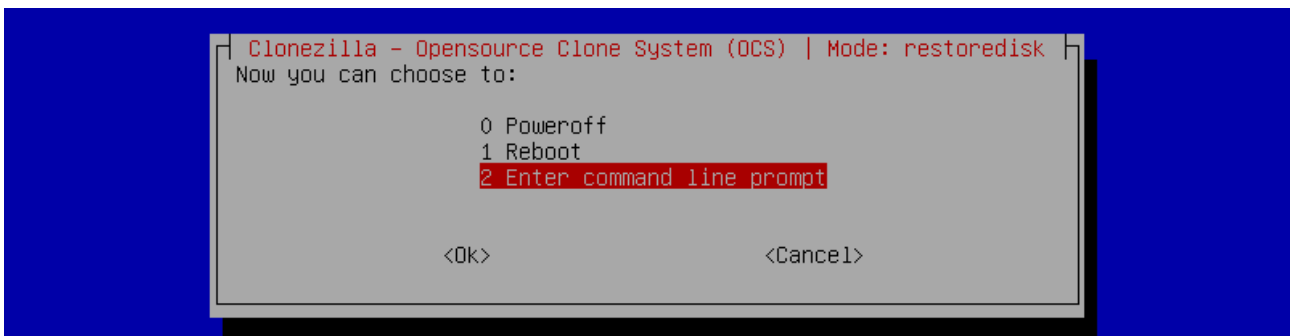

- Select **Start over** and press **ENTER** key

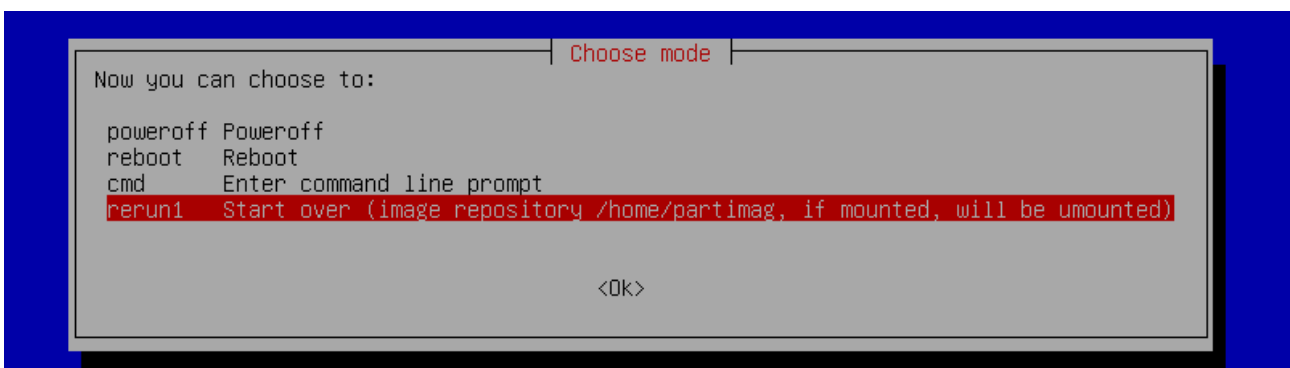

- Choose **RESTORE_DISK_D_PCM3365** to restore *disk D:* and press **ENTER** key

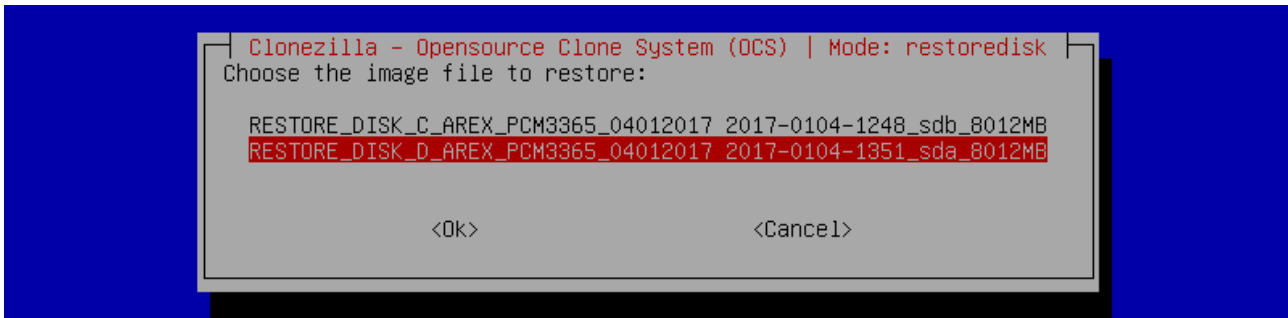

- In the next screen, choose **sda** as target disk and press **ENTER** key
- Wait for the end of the procedure (about 2 minutes):

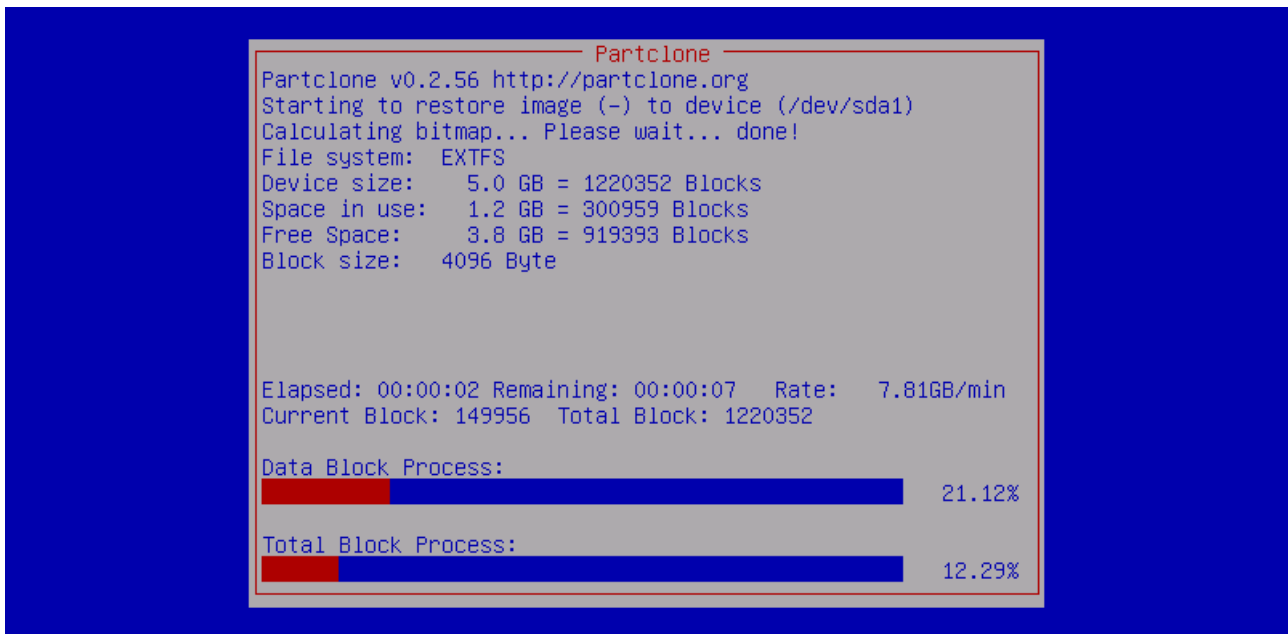

- Select **Poweroff** and press **ENTER** key

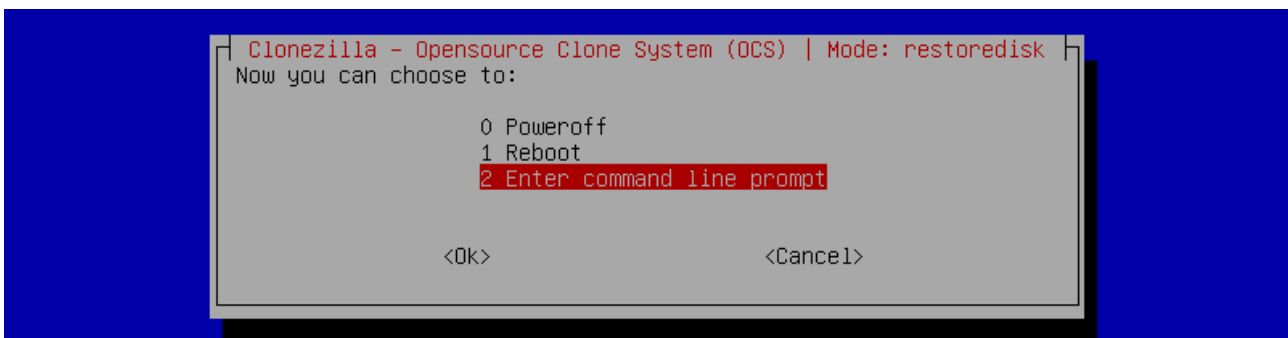

- Wait some seconds until the shutdown process is done
- Turn OFF the system using the main switch
- Remove the USB recovery disk from the USB port

Customize the system



NOTE:

In order to work, the system must be customized with the correct configuration file.

- Turn ON the system
- An error message will advise you that Lighter configuration file is not present:



- Press **OK** to continue
- After all drivers are installed click “Restart Later” button in restart window
- Insert the USB recovery disk provided with the system in the USB port
- Navigate to **Fileinz and report** folder on the USB recovery disk
- Copy customized Laser.inz file in D:\DATA\CONFIG folder on the system

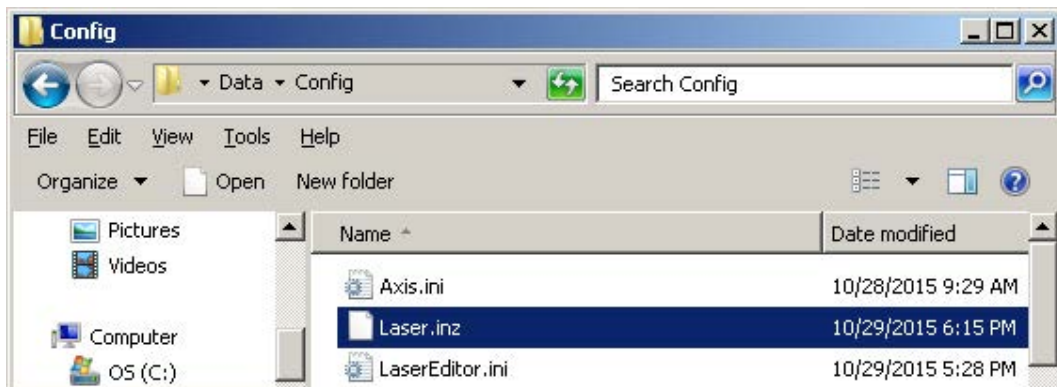

- Select **Test Layouts** folder on the USB recovery disk
- Select the right **test layouts files** based on the laser system model
- Copy the selected **test layouts files** file in D:\DOCS\LAYOUTS folder on the system

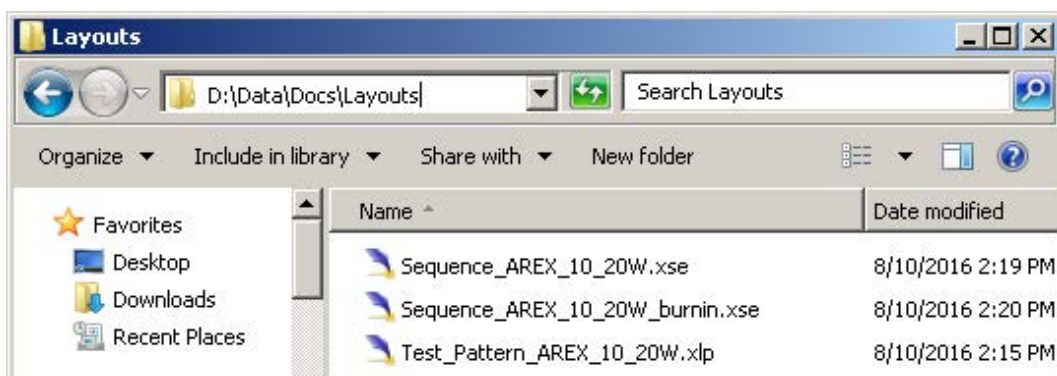

- Double click on shortcut to `save-data.bat` icon in the Desktop
- A message advise you to restart or shutdown the system in order to permanently save data. Press **OK**:

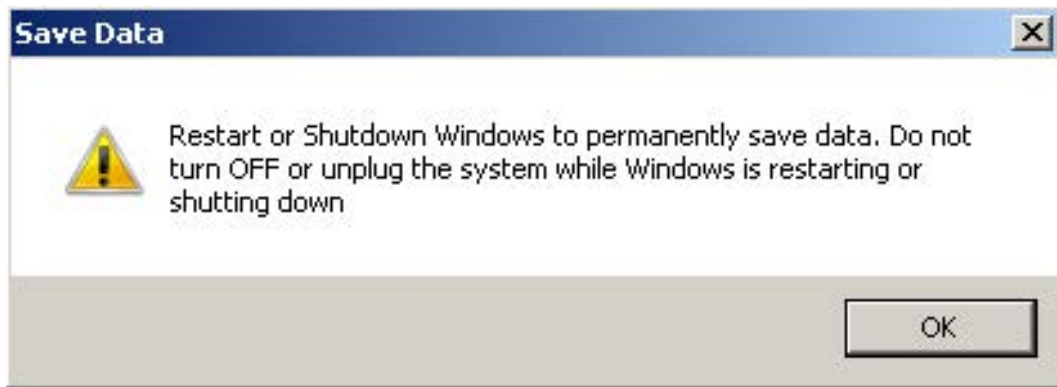

- **Shut down** the system in order to save the new settings:



WARNING!

DO NOT turn **OFF** or **UNPLUG** the system while Windows® is shutting down.

- **WAIT** until system shuts down automatically (black screen)
- Remove the USB recovery disk from the USB port
- Power off the system to complete installation

APPENDIX G: MECHANICAL DRAWINGS

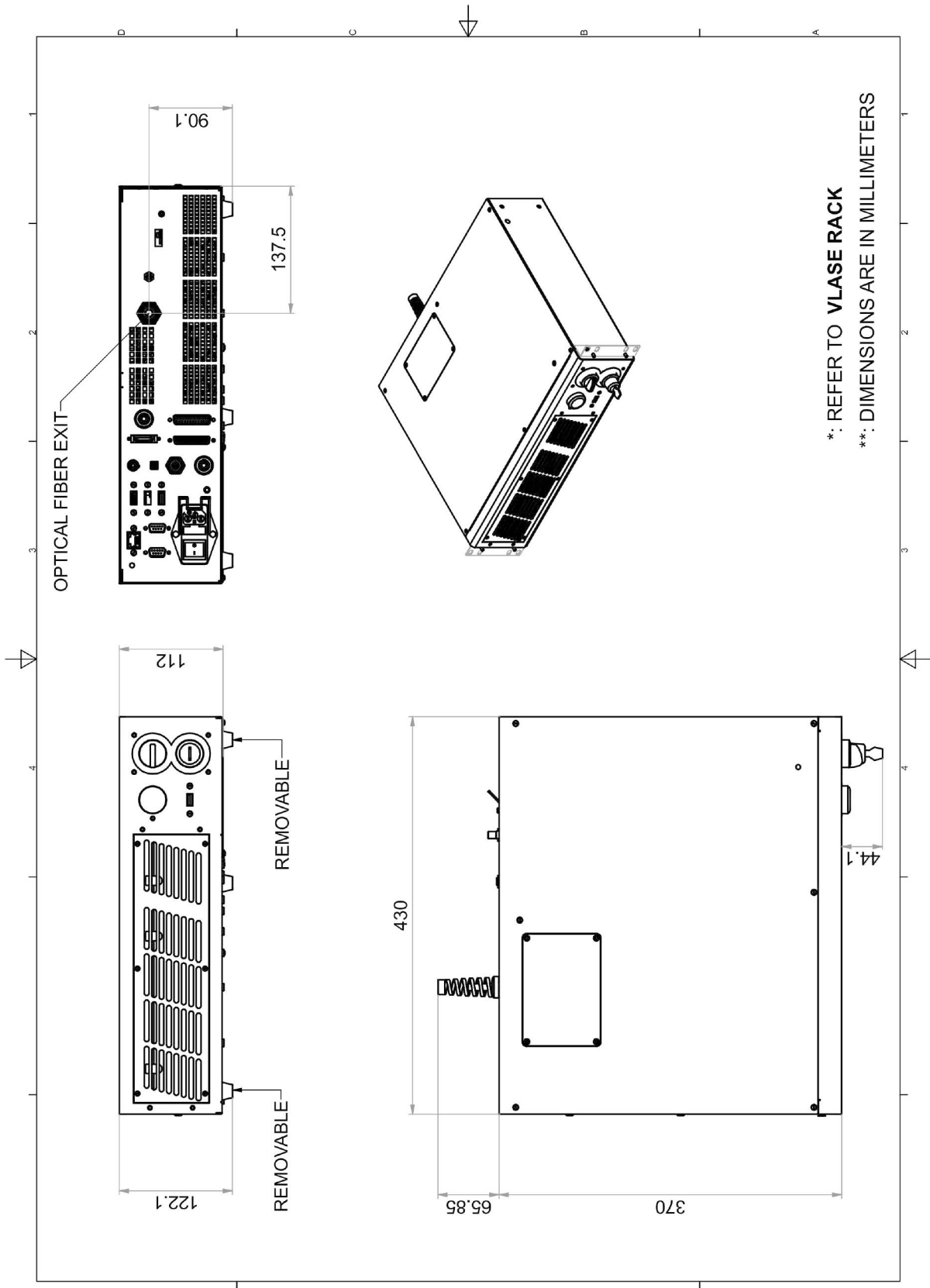

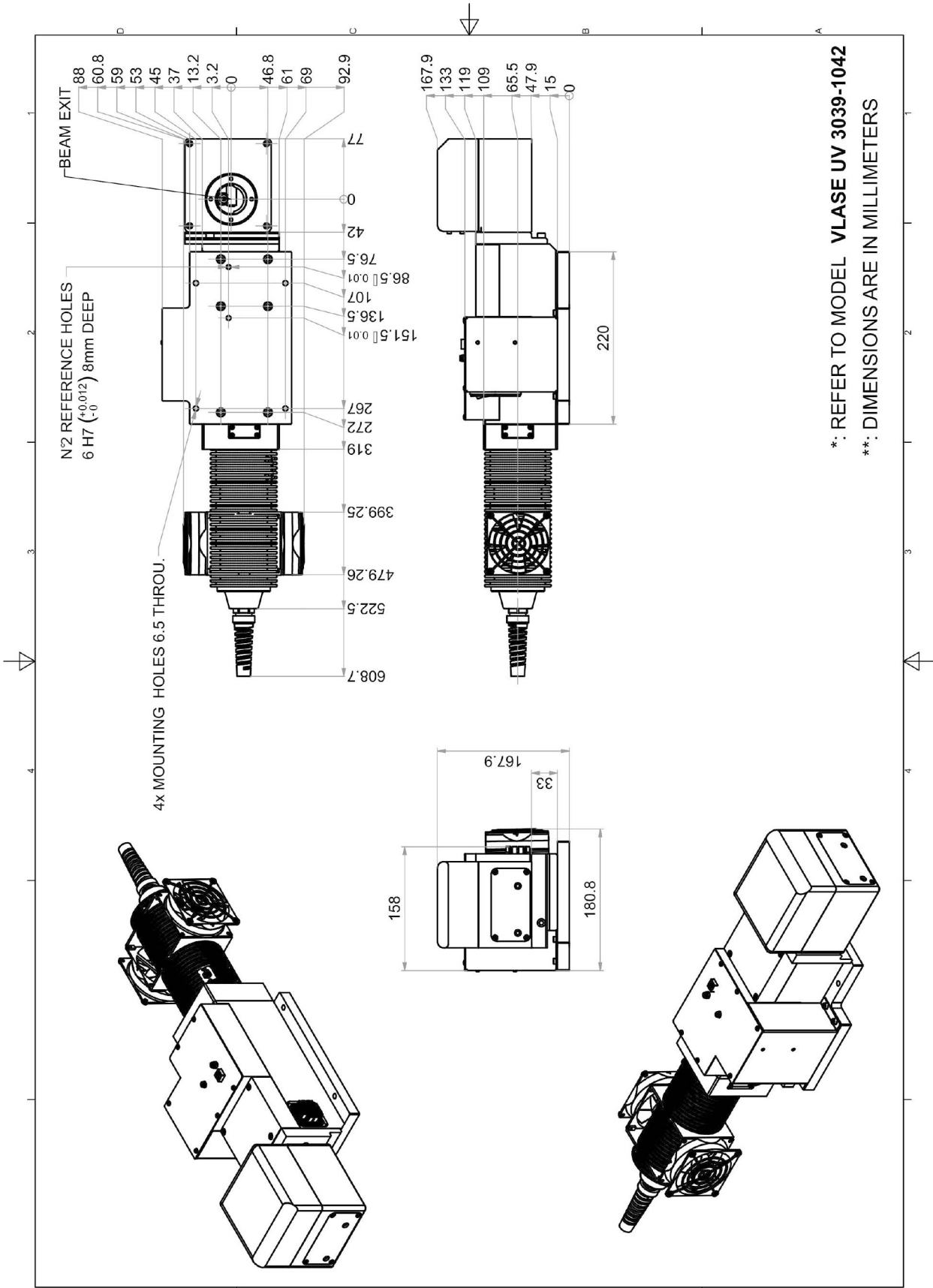

*: REFER TO MODEL VLASE UV 3039-1042
 **: DIMENSIONS ARE IN MILLIMETERS



NOTE:
 Please refer to Datalogic website for detailed drawings.

FIGURES

Figure 1: Control rack and resonator with scan head.....	vii
Figure 2: Unpacking.....	10
Figure 3: Transport.	12
Figure 4: Positioning rack.	13
Figure 5: Vertical positioning (need additional fixing).....	13
Figure 6: Fixing points on rack handles (cabinet assembly).	14
Figure 7: Resonator fixing points.....	14
Figure 8: Rack installation environment.	15
Figure 9: Safety mode example.....	15
Figure 10: Fan installation.	16
Figure 11: Resonator view.....	19
Figure 12: Control rack front view.....	20
Figure 13: Marking area.....	22
Figure 14: Male panel plug cod. TB4M (front view).....	23
Figure 15: Female cable mount connector cod. TY4F (solder view).....	24
Figure 16: Female panel socket cod. 09-9766-30-04 (front view).....	25
Figure 17: Male cable mount connector cod. 09-9767-00-04 (front view).....	25
Figure 18: Female panel socket Sub-D 25 (front view).....	26
Figure 19: <i>ENABLE</i> signal's scheme.....	28
Figure 20: <i>KEY</i> signal's scheme.....	29
Figure 21: Timing control signals.....	29
Figure 22: Timing signals.....	30
Figure 23: Male panel socket Sub-D 25 (front view).	31
Figure 24: Male panel socket Sub-D 9 (front view).	32
Figure 25: Female panel socket cod. 09-3482-87-08 (front view).....	33
Figure 26: Female panel socket cod. 09-3482-87-04 (front view).....	33
Figure 27: Connection examples.....	35
Figure 28: Connecting Command Box cable.....	36
Figure 29: Connecting interlock cable.	37
Figure 30: Connecting interlock OUT connector.	37
Figure 31: Removing the cover plate from the rack.	38
Figure 32: Passing the optical fiber through the cable gland.	38
Figure 33: Passing the optical fiber through the PG cable gland.	39
Figure 34: Connection of the optical fiber.....	39
Figure 35: Fixing the cable gland.	40
Figure 36: Closing cover.....	40
Figure 37: Disassembling the optical fiber cable gland from the resonator.	41

Figure 38: Passing the optical fiber through the cable gland.	41
Figure 39: Connecting the optical fiber to resonator.	42
Figure 40: Final closing.	42
Figure 41: RF cable connection.	43
Figure 42: MDR connection side rack.	44
Figure 43: MDR connection side resonator.	44
Figure 44: Resonator cable connection side rack.	45
Figure 45: Resonator cable connection side resonator.	45
Figure 46: Resonator fan cable connection.	46
Figure 47: Power supply cable connection.	47
Figure 48: Ground connection.	47
Figure 49: Connection the power supply.	48
Figure 50: USB mouse connection.	49
Figure 51: USB keyboard connection.	49
Figure 52: VGA monitor connection.	50
Figure 53: RJ45 Ethernet connection.	50
Figure 54: F-Theta Lens protection cap removal.	51
Figure 55: Power on resonator.	52
Figure 56: Power on control rack.	52
Figure 57: Status LED display.	53
Figure 58: Enable signal <i>KEY</i>	53
Figure 59: Status LED display.	54
Figure 60: Enable command <i>ENABLE</i>	54
Figure 61: Status LED display.	55
Figure 62: Temporal diagram of Software Thermalization.	66
Figure 63: Control Box (Ordering no: 985330031).	78
Figure 64: Kit MOF (Ordering no: 985330027).	79
Figure 65: Cable Kit length plus.	79
Figure 66: handles rack.	80
Figure 67: Cleaning F-Theta lens.	82
Figure 68: Remove of air filter.	83
Figure 69: Positioning of external labels.	87
Figure 70: Positioning of external labels (resonator).	88
Figure 71: Determining the required Performance Level (PLr).	90
Figure 72: Eyeball section.	97



 **DATALOGIC**

www.datalogic.com