

AC Type Controller Integrated 2-Phase-Loop Stepper Motor Driver

■ Configuration Diagram

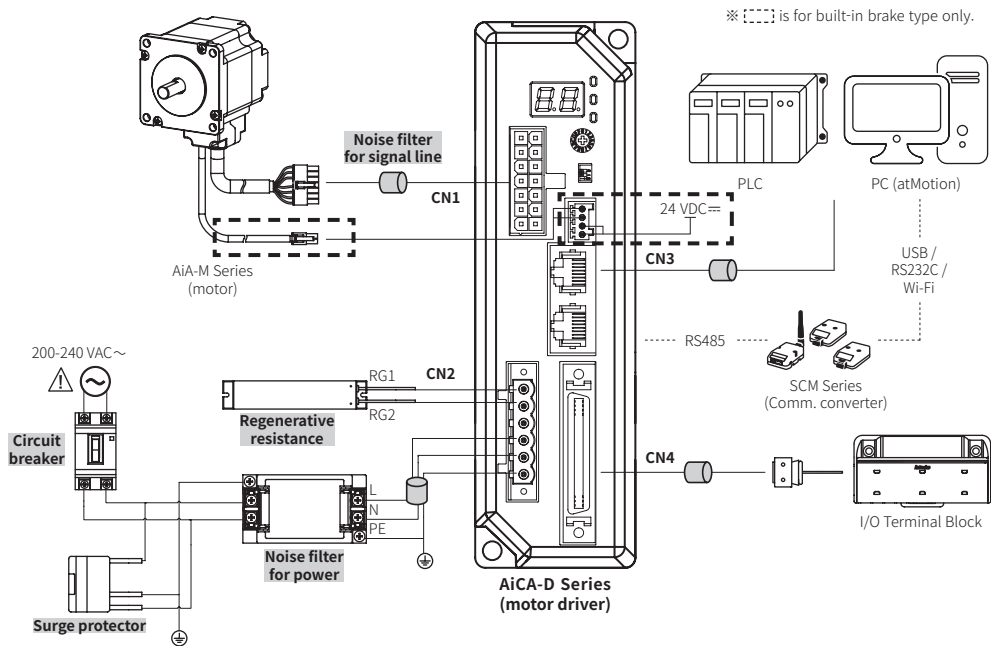

※ The thickness of cable should be same or thicker than the below specifications when connecting the cable for connector.

- ① CN1(motor+encoder connector): AWG22, AWG24
- ② CN2(power connector): AWG18
- ③ CN3(communication connector): AWG28
- ④ CN4(I/O connector): AWG28
- ⑤ CN5(brake connector): AWG22

※ In case of unstable communication due to noise from peripherals and power, use ferrite core in the wiring.

※ is sold separately.

○ Noise filter for signal line

- Connect to wiring to suppress external noise.
- Depending on frequency, filtered noise may different.

Model	Specification	Manufacture
Motor line, I/O signal line	28A5776-0A2	Lairdtech
Comm. line	28A2025-0A2	
Power line	28A5131-0A2	

○ Regenerative resistance

- Connect Pin no. 1, 2 on power connector (CN2).
- Use in condition of the high inertia load or the short deceleration time.
- Forced cooling is required in condition of high surface temperature of regenerative resistance.

Model	Specification	Manufacture
IRC100	<ul style="list-style-type: none"> • Resistance: 100Ω ±5%, • Rated Power: 60W(standby), 100W(heatsink attached) 	Rara Electronics Corp.

○ Noise filter for power

- Connect the power to suppress external noise.
- The wires should be connected as short as possible and grounded.

Model	Specification	Manufacture
RNS-2006	<ul style="list-style-type: none"> • Rated voltage: 250V • Rated current: 6A • Max. leakage current: 1mA 	Orient Electronics

○ Surge protector

- Protect the product from external noise and surge by connecting power.
- ※ Be sure to disconnect the surge protector when testing internal pressure.
- It may result in product damage.

Model	Specification	Manufacture
LT-C12G801W	<ul style="list-style-type: none"> • Nomial discharge current: 2500A • Max. discharge current: 5000A • Voltage protection level: 1.5kV 	OTOWA Electric Co. Ltd

SENSORS
FIELD INSTRUMENTS
CONTROLLERS
MOTION DEVICES
SOFTWARE
(A) Closed Loop Stepper System
(B) Stepper Motors
(C) Stepper Motor Drivers
(D) Motion Controllers

AiCA-D Series

■ Specifications

Model ^{※1}		AiCA-D-60MA(-B)	AiCA-D-60LA(-B)	AiCA-D-86MA(-B)	AiCA-D-86LA(-B)
Power consumption	Power supply	200-240 VAC~ 50/60 Hz			
	STOP ^{※2}	Max. 60 W		Max. 65 W	
	Max. during operation	Max. 160 W	Max. 220 W	Max. 250 W	Max. 300 W
	Max. Run current ^{※3}	2.0 A/Phase			
Auxiliary power ^{※4}	Power supply	24 VDC=			
	Input current	0.3 A		0.5 A	
STOP current		20 to 100 % of max. RUN current			
Rotation speed ^{※5}		0 to 3000 rpm			
Resolution ^{※5}		500 (factory default), 1000, 1600, 2000, 3200, 3600, 5000, 6400, 7200, 10000 PPR			
Speed filter		0 (disable) (factory default), 2, 4, 6, 8, 10, 20, 40, 60, 80, 100, 120, 140, 160, 180, 200 ms			
Motor GAIN		0 (factory default) to 30, Fine Gain			
Positioning range		-2,147,483,648 to +2,147,483,647			
In-Position		Fast Response: 0 (factory default) to 7, Accurate Response: 0 to 7			
Motor rotation direction ^{※5}		CW, CCW			
Status indicator		<ul style="list-style-type: none"> Alarm/Status display part: orange LED 7seg. In-Position indicator: orange LED 		<ul style="list-style-type: none"> Power/Alarm indicator: green/red LED Servo On/Off indicator: blue LED 	
I/O	Input ^{※6}	Exclusive input: 20, general input: 9			
	Output	Exclusive output: 4, general output: 10			
External power supply		VEX (24 VDC= Fixed): 2, GEX (GND): 2			
Operation mode		Jog / Continuous / Index / Program / Position / Torque mode			
Index step		64 steps			
Program function	Step	256 steps			
	Control command	ABS (move absolute position), INC (move incremental position), HOM (home search), ICJ (jump input condition), IRD (waiting input), OPC (ON/OFF of output port), OPT (on pulse from output port), JMP (jump), REP (start repetition), RPE (end repetition), END (end program), POS (position set), TIM (timer), CMP (compare output), TOQ (torque control)			
	Start	Power ON program auto-start function			
	Home start	Power ON home search auto-start function			
RS485 Comm.	Comm. Speed ^{※5}	9600, 19200, 38400, 57600, 115200 (factory default) bps			
Multiaxial control		31-axis			
ID setting switch		16-bit rotary switch (0 to F), 1-bit DIP switch (ON/OFF)			
Alarm		Overcurrent, overspeed, position tracking, overload, overheat, motor connection, encoder connection, overvoltage, undervoltage, motor misalignment, command speed, in-position, memory, emergency stop, program mode, index mode, home search mode, brake			
Warning		±Software limit, ±hardware limit, overload			
Input resistance		4.7 kΩ (Anode Pull-up)			
Insulation resistance		Over 200 MΩ (at 500 VDC= megger)			
Dielectric strength		1,500 VAC~ 60 Hz for 1 min			
Vibration		1.5 mm amplitude at frequency of 10 to 55 Hz (for 1 min) in each X, Y, Z direction for 2 hours			
Shock		300 m/s ² (approx. 30 G) in each X, Y, Z direction for 3 times			
Environment	Ambient temp.	0 to 50 °C, storage: -10 to 60 °C			
	Ambient humi.	35 to 85 %RH, storage: 10 to 90 %RH			
Protection structure		IP20 (IEC standard)			
Approval		CE			
Weight ^{※7}		<ul style="list-style-type: none"> Standard type: Approx. 1,080 g (approx. 800 g) Built-in brake type: Approx. 1050 g (approx. 780 g) 			

※1: The model name indicates driver type. (none: standard type, B: built-in brake type)
E.g.) AiCA-D-60MA-B: built-in brake type stepping motor driver.

※2: Based on the ambient temperature 25 °C, ambient humidity 55 %RH and STOP current 20 %.

※3: RUN current varies depending on the input RUN frequency and max. RUN current at the moment varies also.

※4: Auxiliary power is only available in built-in brake type. Corresponding specification is not available in standard type.

※5: Settable with the dedicated program (atMotion).

※6: Brake ON/OFF function can be changed in general input IN8 in case of built-in brake type only.

※7: The weight includes packaging. The weight in parenthesis is for unit only.

※ Environment resistance is rated at no freezing or condensation.

AC Type Controller Integrated 2-Phase-Loop Stepper Motor Driver

■ Dimensions

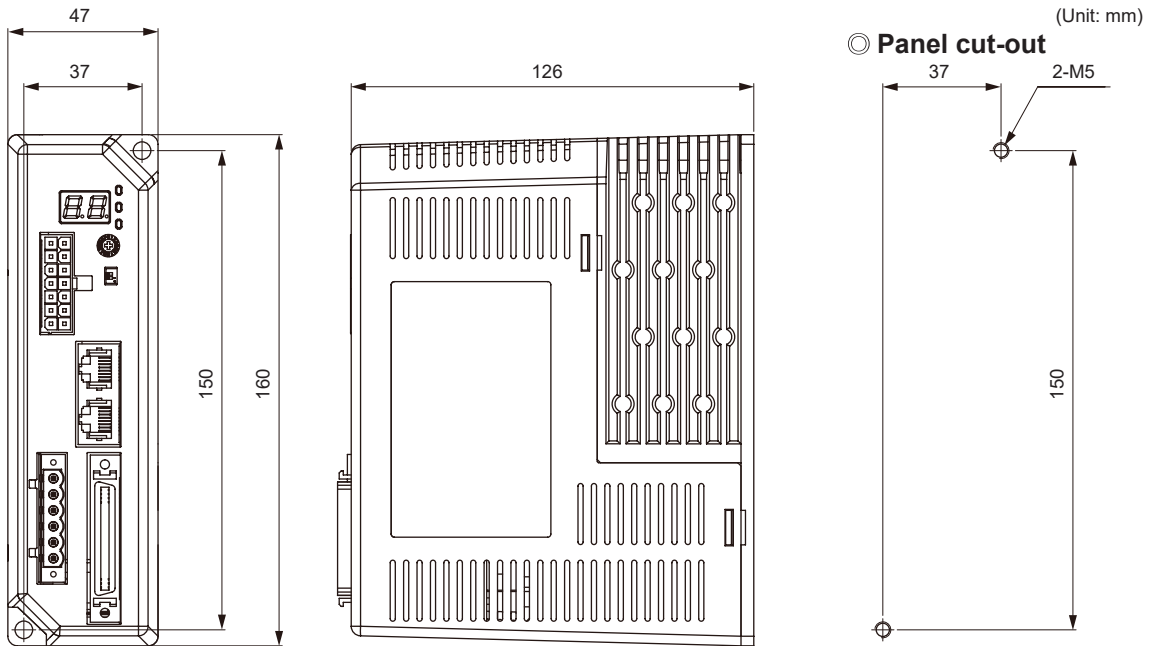

SENSORS
FIELD INSTRUMENTS
CONTROLLERS
MOTION DEVICES
SOFTWARE
(A) Closed Loop Stepper System
(B) Stepper Motors
(C) Stepper Motor Drivers
(D) Motion Controllers

■ Installation

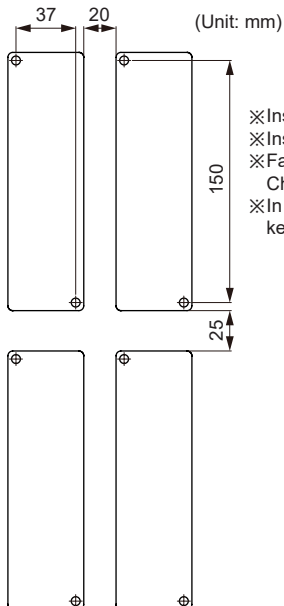

- ※ Install on the metal plate with high thermal conductivity for heat dissipation of the driver.
- ※ Install in the well-ventilated area and install the cooling fan in the unventilated environment.
- ※ Failure to heat dissipation may result in damage or malfunction due to the stress on the product. Check the environment of use within the rated specifications and install on the well-heat dissipated area.
- ※ In case of installing the drivers more than two, keep distance at least 20mm in the horizontal direction and at least 25mm in the vertical direction.

AiCA-D Series

■ Unit Descriptions

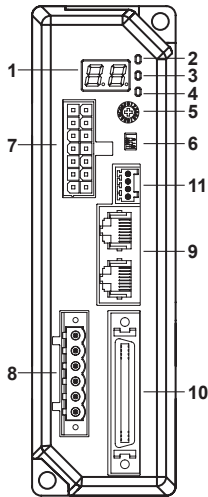

1. Alarm/Status display part (orange)
2. Power/Alarm indicator (PWR/ALM) (green/red)
3. In-Position indicator (INP) (orange)
4. Servo On/Off indicator (SERVO) (blue)
5. Communication ID setting rotary switch (ID Sel setting: 0 to F)
6. Communication ID setting/Terminating resistance DIP switch (ID, TERM)
7. Motor+Encoder connector (CN1)
8. Power connector (CN2)
9. Communication cable connector (CN3)
10. I/O connector (CN4)
11. Brake connector (CN5)^{※1}

※1: Corresponding connector is for built-in brake type only.

■ Driver Status Indicators

Indicator & Display part	LED color	Function	Descriptions
PWR/ALM	Green	Power indicator	Turns ON when the unit operates normally after supplying power.
	Red	Alarm indicator	When alarm occurs, it flashes in various ways depending on the situation. Refer to '■ Control Input/Output → ○ Output → 3. Alarm/Warning'.
INP.	Orange	In-Position indicator	Turns ON when motor is placed at command position after positioning input.
SERVO	Blue	Servo On/Off indicator	Turns ON when Servo is operating, turns OFF when servo is not operating.
Alarm/Status display part	Red	Alarm, status indicator	Displays the corresponding number, status, model, etc. when Alarm occurs.
RxD IN ^{※1}	Yellow	RS485 Data I/O display	Flashes when receiving data.
TxD OUT ^{※1}	Green	RS485 Data I/O display	Flashes when sending data.

※1: Although RS485 OUT is disconnected, RXD IN/TXD OUT operates normally, if RS485 IN is communicating.

■ Driver Setting

○ ID Sel: Communication ID setting switch

※Set Node ID of the driver.

※Depending on the ID setting of the ID/Term switch, it is possible to connect max. 31-axis.

Setting switch	Setting	ID		Setting	ID	
		ID OFF	ID ON		ID OFF	ID ON
 ID Sel	0	Disable	16	8	8	24
	1	1 (factory default)	17	9	9	25
	2	2	18	A	10	26
	3	3	19	B	11	27
	4	4	20	C	12	28
	5	5	21	D	13	29
	6	6	22	E	14	30
	7	23	F	15	31	

○ ID, TERM: Communication ID setting/Terminating resistance DIP switch

※Set Node ID of the driver.

※Set to use terminating resistance.

	No.	Function	Switch position	
			ON	OFF(factory default)
	1	ID setting	ID: 16~31	ID: 1~15
	2	Terminating resistance	Use terminating resistance (120Ω)	Do not use terminating resistance

AC Type Controller Integrated 2-Phase-Loop Stepper Motor Driver

■ Driver Connectors

○ Connector function

● CN1: Motor+Encoder connector

Pin arrangement	Pin no.	Fuction	Pin no.	Function
	1	GND	8	+5VDC≡
	2	Encoder A	9	Encoder \bar{A}
	3	Encoder B	10	Encoder \bar{B}
	4	Encoder Z	11	Encoder \bar{Z}
	5	PE	12	N-C
	6	Motor A	13	Motor B
	7	Motor \bar{A}	14	Motor \bar{B}

● CN2: Power connector

Pin arrangement	Pin no.	Function
	1	Connect regenerative resistance
	2	Connect regenerative resistance
	3	N-C
	4	AC power input
	5	
	6	PE

● CN3: RS485 Communication cable connector

Pin arrangement	Pin no.	Function	Pin no.	Function
	1	N-C	5	N-C
	2	N-C	6	RS485 DATA-
	3	RS485 DATA+	7	N-C
	4	N-C	8	N-C

● CN4: I/O connector

Pin arrangement	Pin	I/O	Function	Pin	I/O	Function	Pin	I/O	Function	Pin	I/O	Function
	1	—	N-C	14	Input	MD1/HMD1	27	Input	IN1	40	Output	Compare2 (Trigger)
	2	—	N-C	15	Input	Pause	28	Input	IN2	41	Output	OUT0
	3	Input	Reset	16	Input	Servo On/Off	29	—	N-C	42	Output	OUT1
	4	Input	Start	17	Input	Home	30	Input	IN3	43	Output	OUT2
	5	Input	Stop	18	Input	Alarm Reset	31	Input	IN4	44	Output	OUT3
	6	Input	EMG	19	Input	+Limit	32	Input	IN5	45	Output	OUT4
	7	Input	Step0/+Run/+Jog	20	Input	-Limit	33	Input	IN6	46	Output	OUT5
	8	Input	Step1/-Run/-Jog	21	Input	ORG	34	Input	IN7	47	Output	OUT6
	9	Input	Step2/SSP0	22	Input	SD	35	Input	IN8/ Brake ON/OFF*	48	Output	OUT7
	10	Input	Step3/SSP1	23	Output	In-Position	36	Input	VEX	49	Output	OUT8
	11	Input	Step4/MSP0	24	Input	VEX	37	Input	GEX	50	Output	OUT9
	12	Input	Step5/MSP1	25	Input	GEX	38	Output	Alarm	—	—	—
	13	Input	MD0/HMD0	26	Input	IN0	39	Output	Compare1 (Trigger)	—	—	—

※Brake ON/OFF function is added for built-in brake type.

● CN4: Brake connector

Pin arrangement	Pin no.	Function
	1	24 VDC≡
	2	GND
	3	Brake+
	4	Brake-

※Corresponding connector is for built-in brake type only.

○ Connector Specifications

Type	Specifications			Manufacture
	Connector	Connector terminal	Housing	
CN1 Motor+Encoder	5557-14R	5556T	—	Molex
CN2 Power	5ESDVM-06P-OR	—	—	Dinkle
CN3 Communication	LS-CV-J45BBKZ	—	—	EPN.
CN4 I/O connector	10150-3000PE	—	10350-52F0-008	3M
CN5 Brake connector	ESC250V-S2330704P	—	—	Dinkle

※Above connectors are suitable for AiCA-D Series

SENSORS
FIELD INSTRUMENTS
CONTROLLERS
MOTION DEVICES
SOFTWARE

(A) Closed Loop Stepper System
(B) Stepper Motors
(C) Stepper Motor Drivers
(D) Motion Controllers

AiCA-D Series

■ Sold Separately

※Recommended to use ferrite core at both ends of the I/O cable and Motor+Encoder cable.

○ I/O Cable

- CO50-MP□-R
(Standard: AiC TAG)

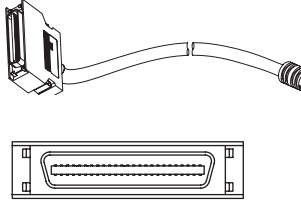

Pin no.	Function (Name TAG)	Cable color	Dot line color-numbers	Pin no.	Function (Name TAG)	Cable color	Dot line color-numbers
1	Brake+	Orange	Black-1	26	IN0	White	Red-3
2	Brake-		Red-1	27	IN1		Black-4
3	Reset		Black-2	28	IN2		Red-4
4	Start		Red-2	29	N-C		Black-5
5	Stop		Black-3	30	IN3		Red-5
6	EMG		Red-3	31	IN4	Black-1	
7	Step0/+Run/+Jog	Yellow	Black-4	32	IN5	Gray	Red-1
8	Step1/-Run/-Jog		Red-4	33	IN6		Black-2
9	Step2/SSP0		Black-5	34	IN7		Red-2
10	Step3/SSP1		Red-5	35	IN8/Brake ON/OFF		Black-3
11	Step4/MSP0		Black-1	36	VEX		Red-3
12	Step5/MSP1		Red-1	37	GEX		Black-4
13	MD0/HMD0		Black-2	38	Alarm		Red-4
14	MD1/HMD1		Red-2	39	Compare1		Black-5
15	Pause		Black-3	40	Compare2		Red-5
16	Servo On/Off		Red-3	41	OUT0		Black-1
17	Home	Black-4	42	OUT1	Red-1		
18	Alarm Reset	Red-4	43	OUT2	Black-2		
19	+Limit	Black-5	44	OUT3	Red-2		
20	-Limit	Red-5	45	OUT4	Black-3		
21	ORG	White	Black-1	46	OUT5	Pink	Red-3
22	SD		Red-1	47	OUT6		Black-4
23	In-Position		Black-2	48	OUT7		Red-4
24	VEX		Red-2	49	OUT8		Black-5
25	GEX		Black-3	50	OUT9		Red-5

※□ of model name indicates cable length (010, 020, 030, 050, 070, 100, 150, 200).
E.g.)CJ-MP50-HP070: 7m I/O cable

○ Motor+Encoder cable

- Normal: C1D14M-□, Moving: C1DF14M-□

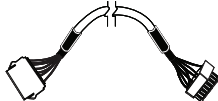

※□ of model name indicates cable length (1, 2, 3, 5, 7, 10, 15, 20).
E.g.) C1DF14M-10: 10m moving type motor+encoder cable

○ Communication converter

- SCM-WF48
(Wi-Fi to RS485-USB wireless communication converter)



- SCM-US48I
(USB to RS485 converter)



- SCM-38I
(RS232C to RS485 converter)



AC Type Controller Integrated 2-Phase-Loop Stepper Motor Driver

Control Input/Output

Inner signal of all input/output consists of photocoupler.
 ON [H]: photocoupler power ON
 OFF [L]: photocoupler power OFF

Input

1. Exclusive input (20)

Signal name	Descriptions	Pin no.	Signal name	Descriptions	Pin no.
Reset	Reset command	3	Pause	Pause	15
Start	Drive start command	4	Servo On/Off	Servo On/Off	16
Stop	Drive stop command	5	Home	Home search	17
EMG	Drive emergency stop command	6	Alarm Reset	Alarm reset command	18
Step0/+Run/+Jog	Step designate 0 / +Run / +Jog	7	+Limit	+direction limit sensor	19
Step1/-Run/-Jog	Step designate 1 / +Run / +Jog	8	-Limit	-direction limit sensor	20
Step2/SSP0	Step designate 2 / Start speed designate 0	9	ORG	Home sensor	21
Step3/SSP1	Step designate 3 / Start speed designate 1	10	SD	Dceleration (deceleration stop) signal	22
Step4/MSP0	Step designate 4 / Max. Speed designate 0	11	Brake ON/OFF	Brake ON/OFF	35
Step5/MSP1	Step designate 5 / Max. Speed designate 1	12			
MD0/HMD0	Operation mode designate 0 / Home search mode designate 0	13			
MD1/HMD1	Operation mode designate 1 / Home search mode designate 1	14			

2. General input (9)

Signal name	Descriptions	Pin no.
IN0-IN2	General input 0 to 2	26 to 28
IN3-IN8	General input 3 to 8	30 to 35

3. Example of input circuit connection

-In case of input, use external power (VEX) 24VDC...

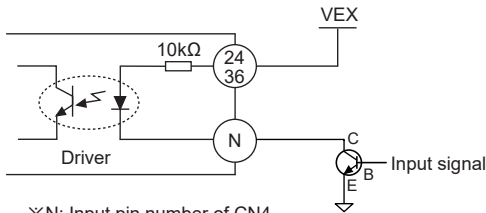

Output

1. Exclusive output (4)

Signal name	Descriptions	Pin no.	Signal name	Descriptions	Pin no.
In-Position	Drive ending pulse	23	Compare1(Trigger)	Comparison output 1	39
Alarm	Alarm output	38	Compare2(Trigger)	Comparison output 2	40

2. In-Position

-In-Position output represents output is output of positioning completion signal.

-If the gap between target position and real position is under In-Position setting value after position command pulse has finished, In-Position output turns ON and In-Position indicator turns ON.

-In reverse, when the gap is over In-Position setting value, In-Position output turns OFF and the In-Position indicator turns OFF.

※For accurate drive, check the In-Position output again and execute the next drive.

※Refer to '6. example of output circuit connection'.

Fast Response		Accurate Response	
Setting	Value	Setting	Value
0 (factory default)	0	8	0
1	±1	9	±1
2	±2	10	±2
3	±3	11	±3
4	±4	12	±4
5	±5	13	±5
6	±6	14	±6
7	±7	15	±7

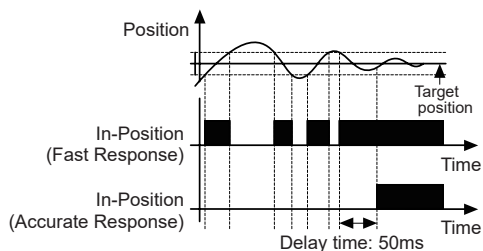

SENSORS
FIELD INSTRUMENTS
CONTROLLERS
MOTION DEVICES
SOFTWARE
(A) Closed Loop Stepper System
(B) Stepper Motors
(C) Stepper Motor Drivers
(D) Motion Controllers

■ Control Input/Output

3. Alarm/Warning

● Alarm

- This function stops motor to protect driver, depending on the error status such as overcurrent or overspeed.
- In case of normal status, output turns ON, and in case of alarming status, output turns OFF.
- When supplying alarm reset, driver returns to the normal status.
- ※Refer to '6. example of output circuit connection'.

● Warning

- This function notices dangers with the alarm indicator prior to motor stop with limit signal or overload alarm.
- When turning out from the alarming condition, driver returns to the normal status automatically.

● Alarm/Warning indicator

- When alarm occurs, the alarm indicator (ALM, red) flashes as the times of corresponding alarm type.
- The alarm/status display part displays the number of the corresponding alarm type.

Alarm/Status	Alarm type	Descriptions	Motor status	Torque status	Brake status ^{※1}
E1	Overcurrent error	When overcurrent flows at motor RUN element	Stop	Release	Lock
E2	Overspeed error	When motor speed is over 4,000rpm			
E3	Position tracking error	When the gap between position command value and current position value is over 90°			
E4	Overload error	When applying load over the rated load for over 1 sec			
E5	Overheat error	When heatsink temperature is over 80°C			
E6	Motor connection error	When motor cable connection error occurs at driver			
E7	Encoder connection error	When encoder cable connection error occurs at driver			
E8	Overvoltage error	When input voltage is over 240VAC~ +10%			
E9	Undervoltage error	When input voltage is under 200VAC~ -10%			
EA	Motor misalignment	When motor is in misalignment			
Eb	Command pulse error	When input pulse is over 3,500rpm	Stop	Remain	Release
		When pulse is input before initial alignment			
EC	In-Position error	When position error (over 1) is kept over 3 sec, after motor stopped.			
Ed	Memory error	When memory error is detected as power supplied			
EE	Emergency stop	When emergently stopped with emergency stop command			
EF	Program mode error	When 'END' command is not exist at the last step			
EG	Index mode error	When other instruction is used but 'INC', 'ABS'			
		When index command is not completed du to the stop command			
EH	Home search mode error	When failed to find home			
EJ	Brake error ^{※1}	When brake failed to operate			

※Depending on the alarm/warning type, it displays as a segment on the Alarm/Status display part.

Warning/Status	Warning type	Descriptions	Motor status	Torque status	Brake status ^{※1}
W1	+Software limit	When normal direction (CW) software limit is ON.	Stop	Remain	Release
	-Software limit	When reverse direction (CCW) software limit is ON.			
W3	+Hardware limit	When normal direction (CW) hardware limit is ON.			
	-Hardware limit	When reverse direction (CCW) hardware limit is ON.			
W5	Overload warning	When maximum load is kept connected over 10 sec. (may cause overheat on motor and driver)	Remain	Remain	Release
W6	Position override warning	When it is impossible to operate position override.	Stop	Remain	Release

※1: Corresponding information is for built-in brake type only.

※ Even though warning occurs, it drives as normal status and it may cause damage by fire. It is recommended not to use the unit during warning status.

※ When alarm/warning occurs, indicators flash with interval of 0.4 sec until the alarm/warning is cleared.

<E.g. when alarm no. 3 occurs>

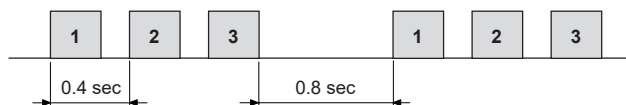

AC Type Controller Integrated 2-Phase-Loop Stepper Motor Driver

Control Input/Output

4. Comparison output (Compare1, Compare2)

It outputs trigger pulse at the designated cycle.

Mode	Description
0	Not use comparison output.
1	Comparison output turns ON when the present absolute position value is same or bigger than the set position value.
2	Comparison output turns ON when the present absolute position value is same or smaller than the set position value.
3	Trigger pulses output with the set interval and width.

※Please refer to the user manual to learn how to set.

5. General output (10)

Signal name	Descriptions	Pin no.
OUT0 to OUT9	General output 0 to 9	41 to 50

6. Example of output circuit connection

-In case of output, use external power (VEX) max. 12 to 24 VDC, 100mA.

When current exceeds 10mA, use an external resistor R_L to adjust the current value.

$$\times R_L = \frac{VEX - 0.7V - V_F}{0.01A}$$

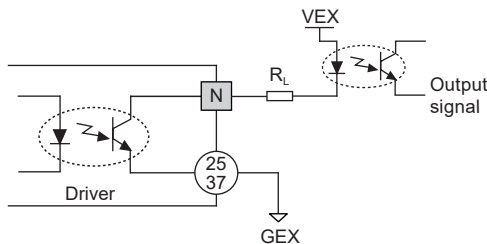

※N: Output pin number of CN4

Communication Output

It is for parameter setting and monitoring via external devices (PC, PLC, etc.).

Interface

Comm. protocol	Modbus RTU	Comm. speed	9600, 19200, 38400, 57600, 115200 bps
Connection type	RS485	Comm. response wait time	5 to 99ms
Application standard	Compliance with EIA RS485	Start bit	1bit (fixed)
Max. connections	31 units (address: 01 to 31)	Data bit	8bit (fixed)
Synchronous method	Asynchronous	Parity bit	None, Even, Odd
Comm. method	Two-wire half duplex	Stop bit	1-bit, 2-bit
Comm. distance	Max. 800m		

※It is not allowed to set overlapping communication address at the same communication line.

Use twisted pair wire for RS485 communication.

Application of system organization

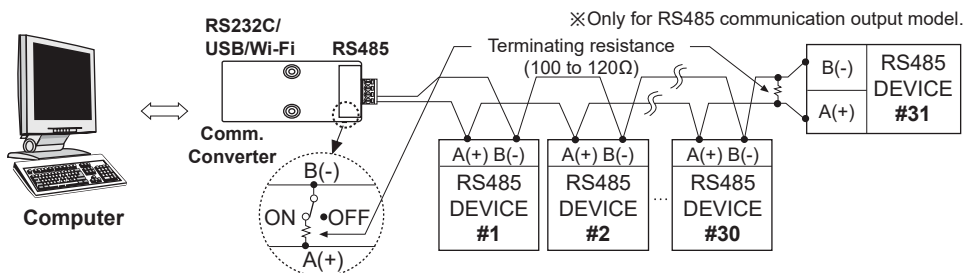

※It is recommended to use Autonics communication converter;

SCM-WF48 (Wi-Fi to RS485-USB wireless communication converter, sold separately),

SCM-US481 (USB to RS485 converter, sold separately), SCM-381 (RS232C to RS485 converter, sold separately).

Please use twisted pair wire, which is suitable for RS485 communication, for SCM-WF48, SCM-US481 and SCM-381.

SENSORS

FIELD INSTRUMENTS

CONTROLLERS

MOTION DEVICES

SOFTWARE

(A) Closed Loop Stepper System

(B) Stepper Motors

(C) Stepper Motor Drivers

(D) Motion Controllers

AiCA-D Series

■ Connection of Motor and Driver

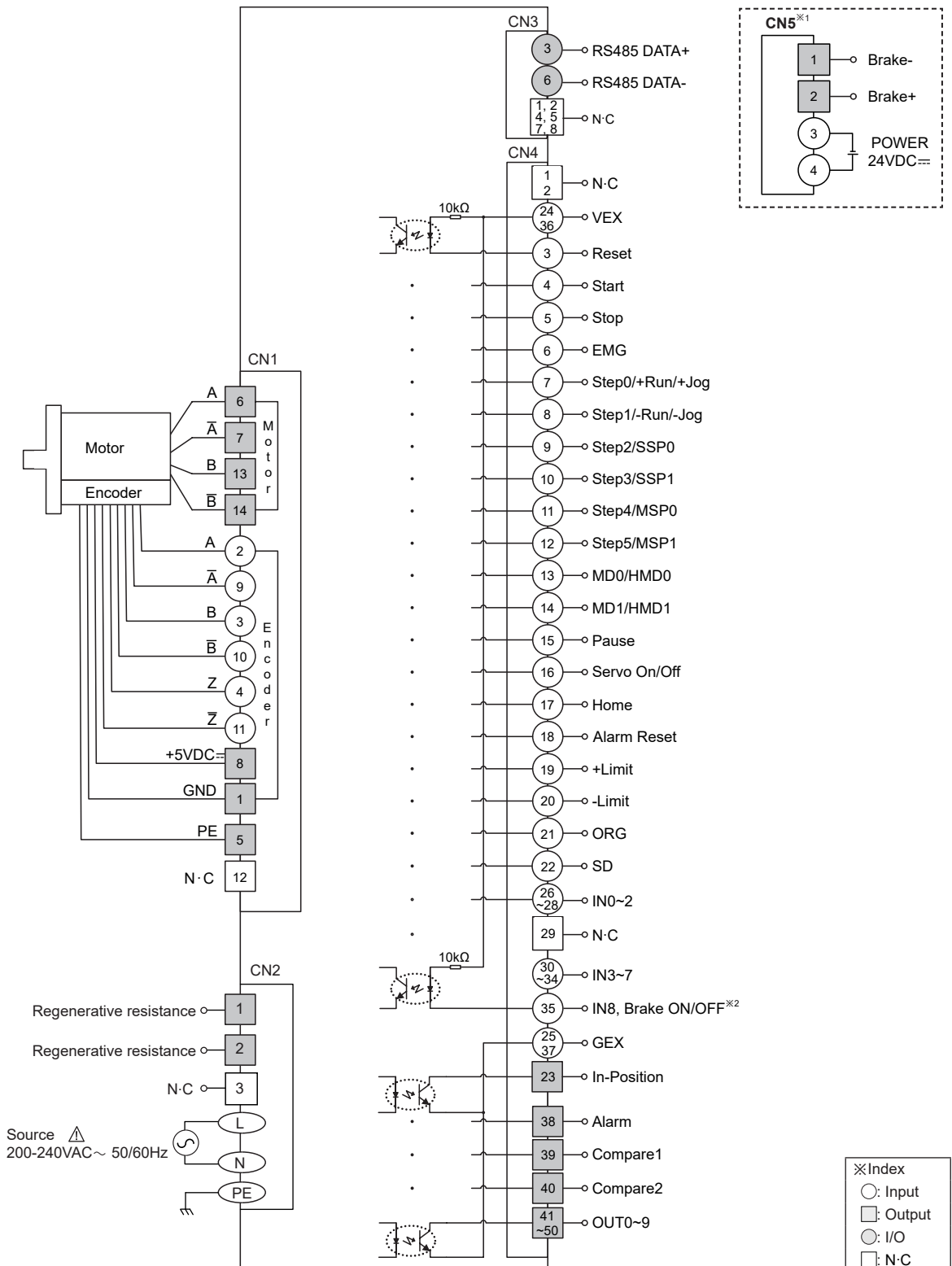

※1: Corresponding connector is for built-in brake type only.

※2: In built-in brake type, the corresponding pin can be switched as Brake ON/OFF.

AC Type Controller Integrated 2-Phase-Loop Stepper Motor Driver

■ Troubleshooting

Malfunction	Causes	Troubleshooting
When communication is not connected	The communication cable is not connected.	Check communication cable wiring. Check communication cable connection correctly.
	The communication port or speed settings are not correct.	Check communication port and speed settings are correct.
When motor does not excite	Servo is not ON.	Check that servo On/Off input signal is [L]. In case of [H], servo is off and excitation of motor is released.
	Alarm occurs.	Check the alarm type and remove the cause of alarm.
When motor rotates to the opposite direction of the designated direction	MotorDir parameter setting is not correct.	Check the MotorDir parameter settings.
When motor drive is unstable	Connection between motor and encoder is unstable.	Check the Motor+Encoder connection cable.
	Motor gain value is not correct.	Change the Motor Gain parameter as the certain value.

■ Proper Usage

- Follow instructions in 'Proper Usage'.
Otherwise, It may cause unexpected accidents.
- It is recommended to use 485 converter with the separate power.
(Autonics product, SCM-38I, recommended)
- Install vertically so that the Alarm/Status display part located on top.
- Keep the distance between power cable and signal cable more than 10cm.
- Do not input external signal until the driver is initialized (In-Position LED ON) after power is applied.
- Motor vibration and noise can occur in specific frequency period
 - ① Change motor installation method or attach the damper.
 - ② Use the unit out of the dedicated frequency range when vibration and noise occurs due to changing motor RUN speed.
- For using motor, it is recommended to maintenance and inspection regularly.
 - ① Unwinding bolts and connection parts for the unit installation and load connection
 - ② Strange sound from ball bearing of the unit
 - ③ Damage and stress of lead cable of the unit
 - ④ Connection error with motor
 - ⑤ Inconsistency between the axis of motor output and the center, concentric (eccentric, declination) of the load, etc.
- This product does not prepare protection function for a motor.
- This unit may be used in the following environments.
 - ① Indoors (in the environment condition rated in 'Specifications')
 - ② Altitude max. 2,000m
 - ③ Pollution degree 2
 - ④ Installation category II

SENSORS
FIELD INSTRUMENTS
CONTROLLERS
MOTION DEVICES
SOFTWARE
(A) Closed Loop Stepper System
(B) Stepper Motors
(C) Stepper Motor Drivers
(D) Motion Controllers