

Motor Controller

AC Semiconductor Motor Controller

Types RSB..15-B

CARLO GAVAZZI

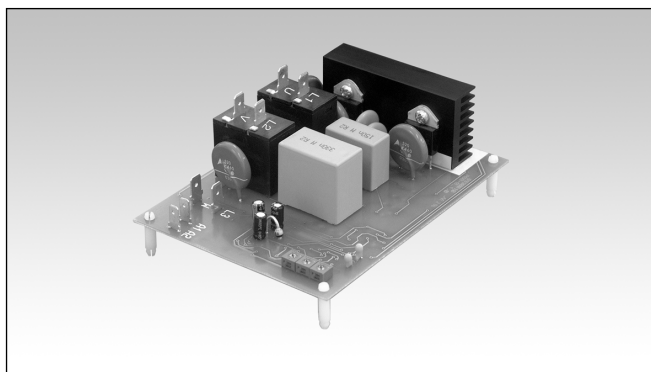

- Soft starting and stopping of 3-phase squirrel cage motors
- Board-level solution
- Rated operational voltage: up to 480 VACrms, 50/60 Hz
- Rated operational current: 15 AAC 53 b
- Transient overvoltage protection built-in
- Integral bypassing of semiconductors

Product Description

Easy-to-use AC semiconductor motor controller. With this controller 3-phase motors with nominal load currents up to 15 A can be soft-started and/or soft-stopped. Starting and stopping time as well as initial torque can be independently adjusted by built-in potentiometers.

Ordering Code

RSB 40 15 - B

Board level Motor Controller
 Rated operational voltage
 Rated operational current
 Control voltage

Type Selection

Type	Rated operational voltage U_e	Rated operational Current I_e	Control voltage U_c
RSB: Board level Motor Controller	22: 127/220 VACrms, 50/60Hz 40: 230/400 VACrms, 50/60Hz 48: 277/480 VACrms, 50/60Hz	15: 15AAC	-B: 200...300VAC, 5 mA

Input Specifications (Control Input)

Control voltage U_c A1-A2:	200...300VAC, 5 mA
Rated AC frequency	50/60 Hz -5/+5Hz
Rated insulation voltage	630 V rms Overvoltage cat. III (IEC 60664)
Dielectric strength Dielectric voltage Rated impulse withstand volt.	2 kVAC (rms) 4 kV (1.2/50 μ s)

Supply Specifications

Power supply Rated operational volt. (U_e) through terminals L1-L2-L3	Overvoltage cat. III (IEC 60664) (IEC 60038)
22	127/220 VACrms \pm 15%
40	230/400 VACrms \pm 15%
48	227/480 VACrms \pm 15%
Rated AC frequency	50/60 Hz -5/+5 Hz
Voltage interruption	\leq 40 ms
Dielectric strength Dielectric voltage Rated impulse withstand volt.	2 kVAC (rms) 4 kV (1.2/50 μ s)

Output Specifications

Utilization category	AC-53b Integral bypassing of semiconductors
Overload current profile	15A: AC-53b:3-3:300
Min. load current	200 mAAC rms

General Specifications

Accuracy Ramp up Ramp down Initial torque	6.5 sec \pm 10% on max. 8 sec \pm 10% on max. 0 to 85% \pm 10%
Equipment class	A
EMC Immunity	Electromagnetic Compatibility acc. to EN 61000-6-2
Operating temperature	-20° to +50°C (-4° to +122°F)
Storage temperature	-50° to +85°C (-58° to +185°F)
Control FASTON terminals	4.8 x 0.5 mm
Power FASTON terminals	6.3 x 0.8 mm
Approvals	UL, cUL compliant
CE marking	Yes
Norms	IEC/EN 60947-4-2
Form designation	Form 1
Degree of protection	IP00
Pollution Degree	2

Operation Diagram 1

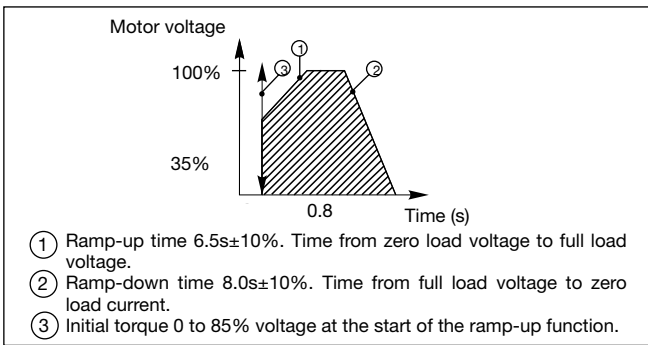

Operation Diagram 2

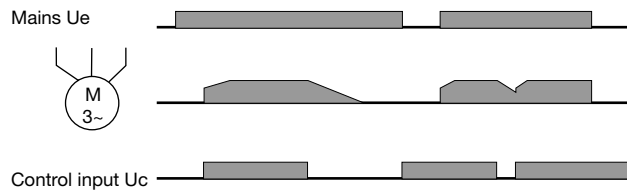

External Protection

1. Recommended semiconductor protection fuses

Type: 6.921 CP URQ 27x60 / 50, Ferraz Shawmut

2. Recommended motor protection circuit breakers

Motor full load current (AACrms)	2.5 - 4	4 - 6.3	6.3 - 9	9 - 12.5	12 - 15
Overload relay type Telemecanique: GV 2-	M 08	M 10	M 14	M 16	M16 M20
Overload relay type ABB:MS 325-	4	6.3	9	12.5	12.5 16
Motor protection circuit breaker type Allan-Bradley: KTA 3-25-	4	6.3	10	16	16

Dimensions

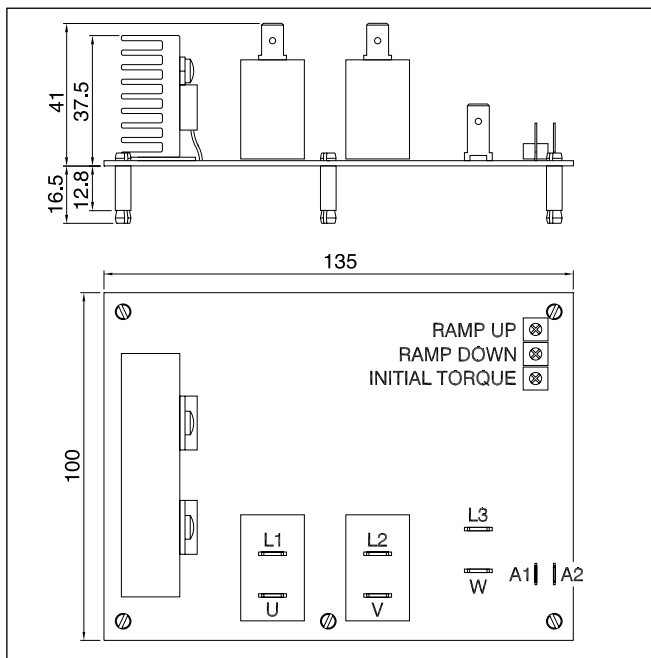

Connection Diagram

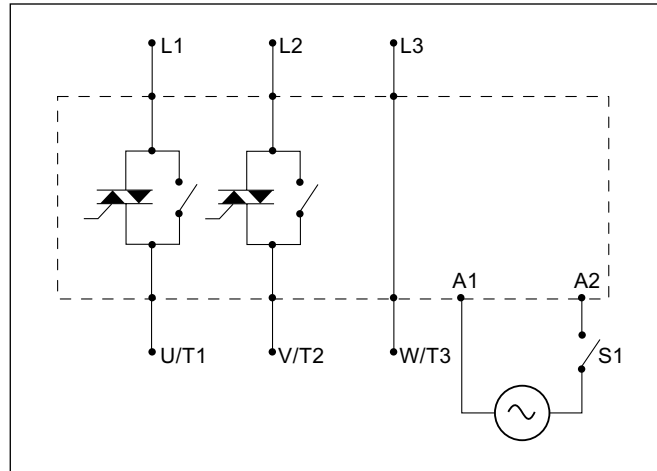

Mode of Operation

This motor controller is intended to be used to soft-start 3-phase compressor induction motors and can reduce the starting currents of the system by up to 40%. Soft-starting is achieved by controlling the motor voltage. During running operation the semiconductors are bypassed by electromechanical relays.

The device rating is based on 12 starts per hour but this can be higher depending on the application. The controller is switching 2 lines. The 3rd line is continuously connected to the load. Overload protection is not provided in this motor controller and must therefore be installed separately.

Wiring Diagrams

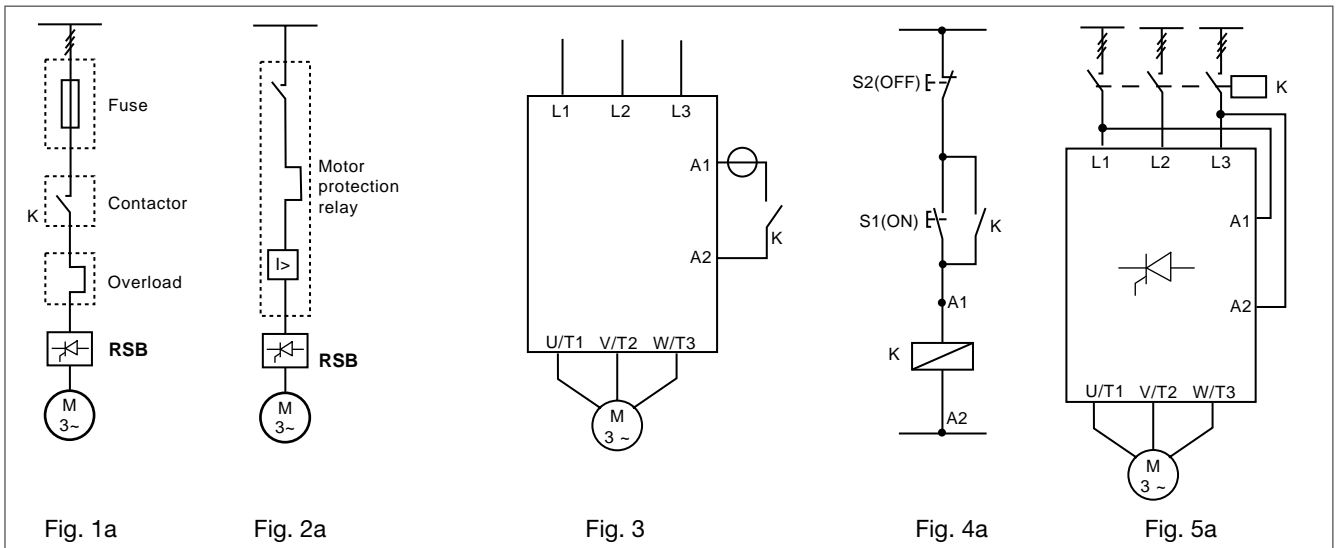

The motor controller provides by-passing of the semiconductors during running operation. Therefore the semiconductors can only be damaged by short-circuit currents during ramp-up and ramp-down. Please note that the motor controller does not insulate the motor from the mains.

Figure 1: Protection of the device when using fuses. Protection with semiconductor fuses is intended to protect the motor feeder and

motor controller from damage due to short-circuit.

Figure 2: Protection using a thermal-magnetic motor protection relay. The motor feeder is protected but damage to the motor controller is possible. When motor failure occurs, if part of the motor winding limits the fault current and the motor feeder is protected, this type of protection can be considered acceptable.

Figure 3: Control using a 2-position switch. When K is closed, the control input is supplied to A1, A2 and soft starting of the motor is performed. When K is opened, soft stopping is performed.

Figure 4: Control using ON and OFF push buttons Pushing S1 soft starts the RSB. Pushing S2 soft stops the RSB. K is an auxiliary contact of the mains contactor.

Figure 5: Control using 2 phases Connecting input A1, A2 to two of the incoming lines will soft start the motor when K is operated. When K is switched off, the motor will stop (no soft stop). This method of control is only valid for model RSB2215-B as max. Control voltage allowed across A1, A2 is 300VAC.

