

## SG-BWS SERIES

The SG-BWS series presents two models:

- **SG-BWS-T4**: control unit with plastic housing for DIN/OMEGA rail mounting equipped with 16 clamps that can connect from 1 to 4 photocell couples of the S5-ST, SL5-ST, S300 series **with OSSD safety outputs**;
- **SG-BWS-T4-MT**: control unit with plastic housing for DIN/OMEGA rail mounting equipped with 48 clamps that can connect from 1 to 4 photocell couples of the S5-ST, SL5-ST, S300 series and contemporaneously up to 2 safety light curtains equipped with safety outputs activated with two 230V relay.

The SG-BWS-T4 model is **WITHOUT MUTING FUNCTION** but presents EDM and selectable MANUAL/AUTOMATIC RESTART. The SG-BWS-T4-MT model is provided with **DOUBLE MUTING FUNCTION**. The control unit fits some safety outputs controlled depending on the status of the safety photocells connected to the device. A danger condition detected by a photocell or light curtain opens the outputs.

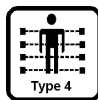

## HIGHLIGHTS

- Two models:
  - SG-BWS-T4 WITHOUT MUTING FUNCTION
  - SG-BWS-T4-MT WITH DOUBLE MUTING FUNCTION
- Factory automation standard housing with compact dimensions
- Possibility to connect 4 safety single-beam and 2 safety light curtains
- PLUS functions: Single/Double muting, Edged/triggered Override, Double Muting Lamp, External Muting Enable
- Configurable device through dip-switches
- Satisfies the requirements of key safety Standards, such as Category 4 of EN 954-1, SIL3 of IEC 61508, and performance levels PL e of EN ISO 13849-1.

## APPLICATIONS

Extreme reliability and simplicity make the SG-BWS control units the ideal solution for the following applications:

- Automatic warehouses
- Machines for food packaging
- Robots
- Automatic assembling lines
- Machines for PCB production

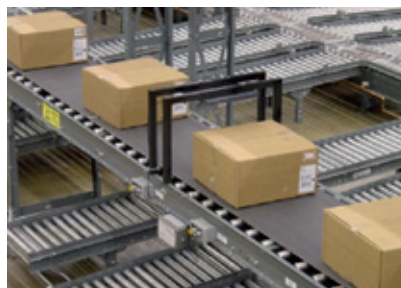

## SETTINGS

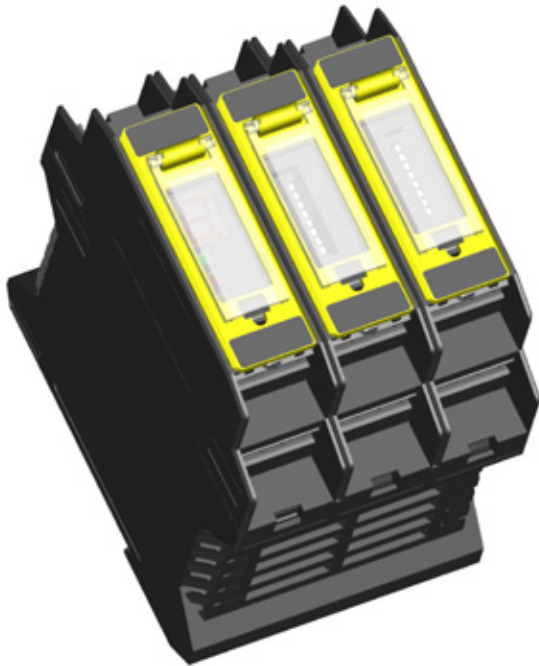

- User interface is present on the top of the SG-BWS-T4 for signalling and configuration.
- Two units made of 8 dip-switches are present on the top of the SG-BWS-T4-MT model. These switches activate/deactivate and configure additional functions integrated in the device.
- Signalling interface and dip-switches are protected from non-authorized access by transparent lids that can be opened using a specific tool.







DIP	PURPOSE	OFF (Default)	ON
1	ENABLE EDM	ENABLED	DISABLED
2	RESET MODE	AUTOMATIC	MANUAL
3	MUTING TIME-OUT	10 MINUTES	INFINITY
4	MUTING DIRECTION	T	L
2	OVERRIDE	EDGED	TRIGGERED
6	MUTING SELECTION	See specific table	
7	MUTING SELECTION		
8	MUTING SELECTION		

The EDM and MAN/AUTO Restart functions integrated in SG-BWS-T4 model can be selected through specific control unit lines (refer "CONNECTION" section of the present document).

## INDICATORS

An user interface is present for viewing warnings and setup is present on the top of both SG-BWS-T4 and SG-BWS-T4-MT control units. Besides the 7-segment display (for diagnostics purposes), the warning components include 3 LEDs:



LED	INDICATION
 POWER	Device is powered correctly
 NORMAL	No danger: safety outputs closed
 SAFE	Danger or fault: safety outputs open
	The 7-segment display shows detailed information on control unit current status

**DOUBLE MUTING FUNCTION SETTING**

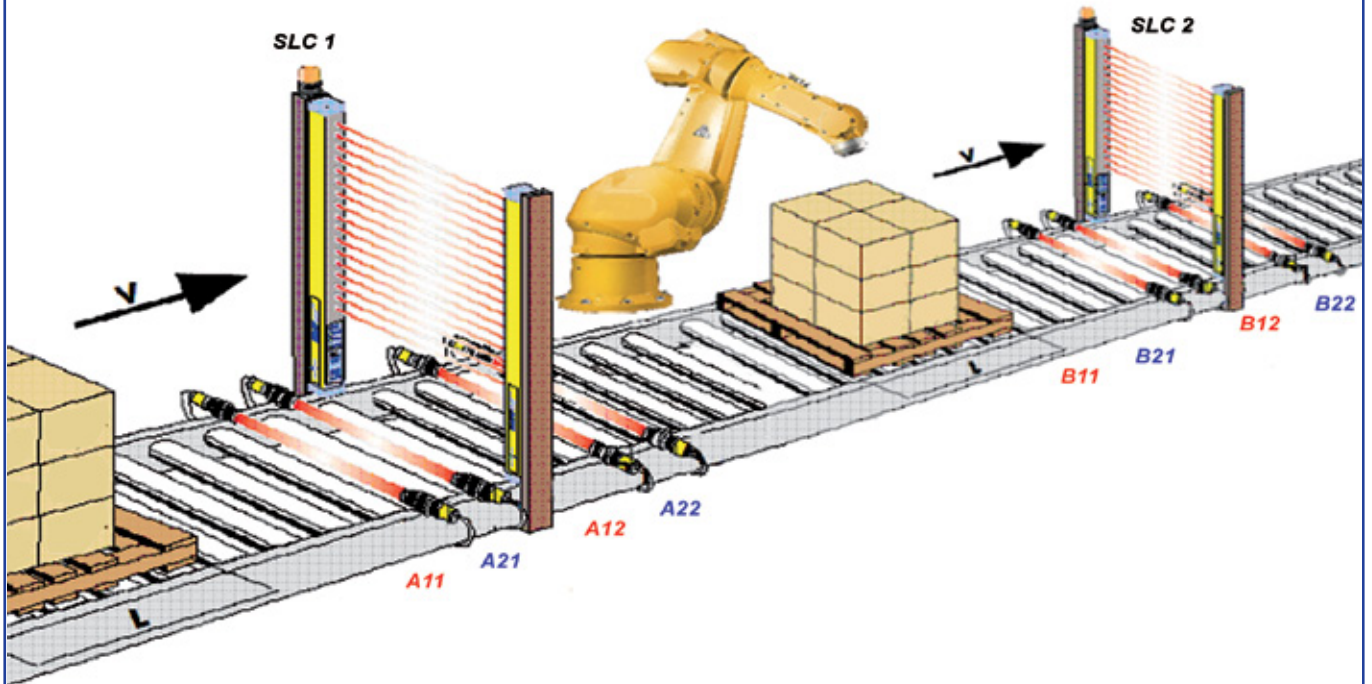

Thanks to its two separate muting channels, SG-BWS-T4-MT can accept the muting request output by sensors without interrupting the safety function on light curtain or safety sensors of both channels. The dip-switches 6-7-8 allow users to couple the single devices to the 2 muting channels available on the SG-BWS-T4-MT control unit. Following table reports all the available combinations.

DIP-SWITCH SETUP	PHOTOCELLS	LIGHT CURTAIN 1	LIGHT CURTAIN 2
000	A	A	A
001	A	A	B
010	A	B	B
011	-	A	B
100	A	B	-
101	-	A	A
110	A	-	-
111	-	-	-

0=OFF, 1=ON, A(B)=Device associated to channel A(B) Default setting: 000

**MUTING WARNING DEVICES**

To use the Muting function it is also required to connect the external Muting warning (lamp) since control unit would lock out if it is missing. One lamp shall be used per channel. If device is preset for use of just one channel, both warning devices are associated to it: in this way, failure of one of the lamps would not lock out system operation. SG-BWS-T4-MT allows installation of both incandescent lamps and LEDs. For the latter case, polarity shall be carefully complied with, as indicated aside.

**Note:** When only 1 muting lamp is used, please connect on the clamps of the other one a 150 ohm > 5W resistor!

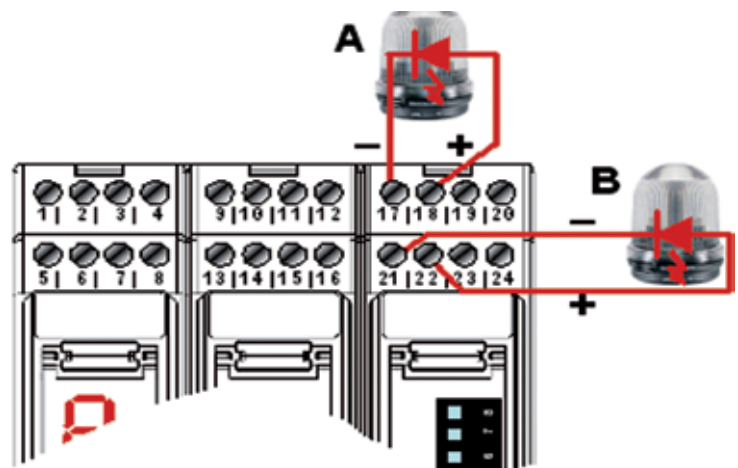

**Note:** the Muting lamp is not supplied with the device. Please refer to "Accessory selection and order information table."

## DIMENSIONS

### SG-BWS-T4

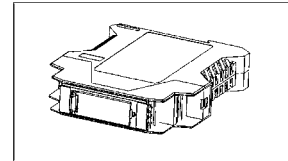
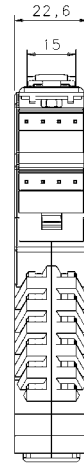
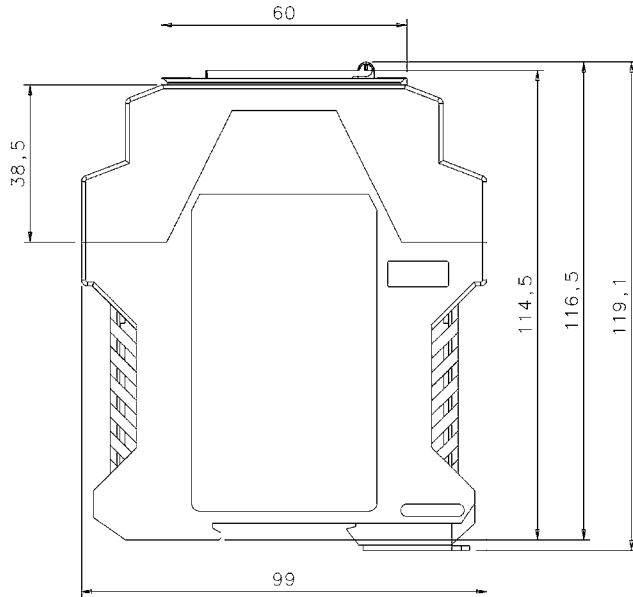

### SG-BWS-T4-MT

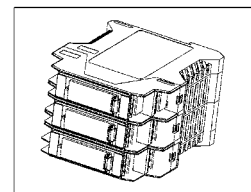
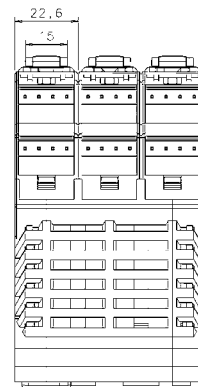
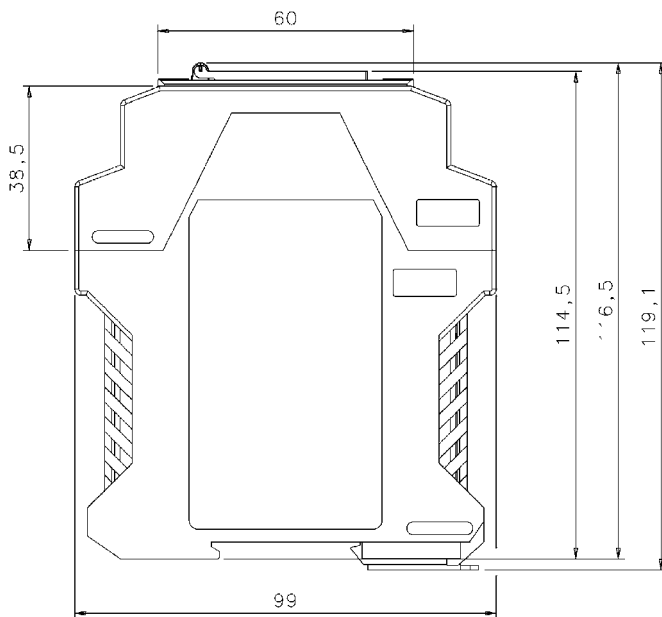

mm

## SG-BWS-T4 CONNECTIONS

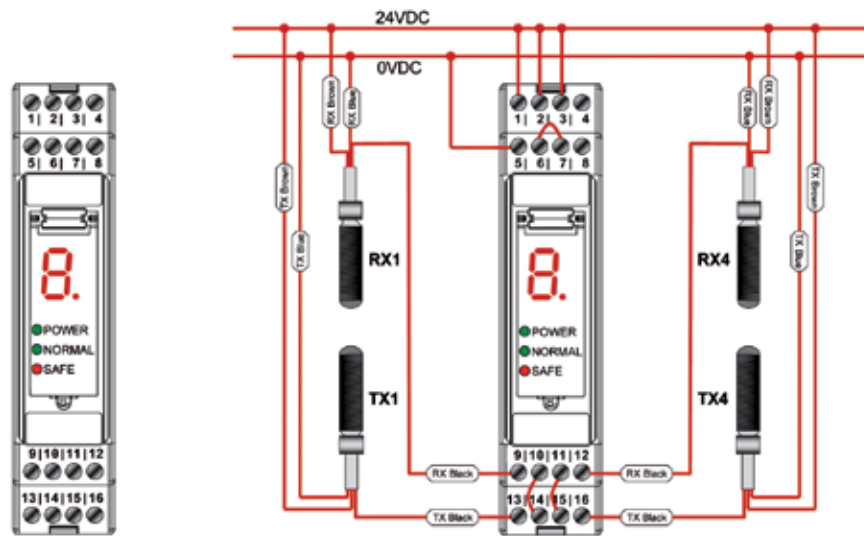

NOTE : As SG-BWS-T4 has OSSD Safety outputs in order to have relay outputs, the device must have EDM function connected to the CS-ME EDM relay box as represented below:

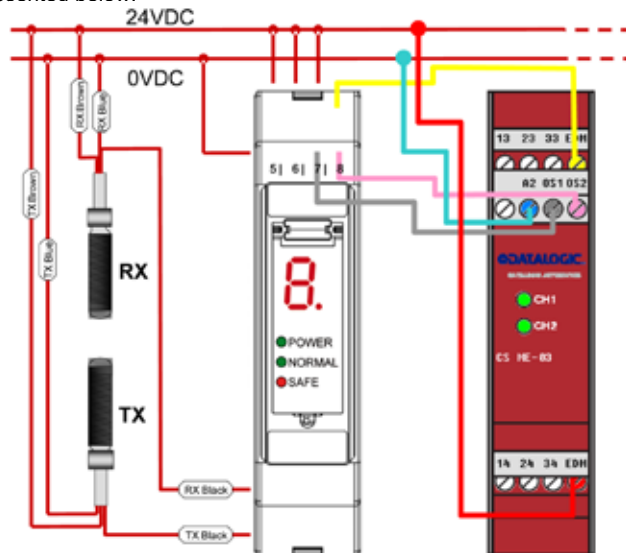

SIGNAL	CONTACT	CONNECTION
VCC	1	External 24Vdc
START/TEST/RESET	2	- Contact NC towards 24Vdc
EDM ENABLE	3	- 24Vdc > EDM DEACTIVATED - Not connected > EDM activated
EDM	4	- NC contact of external relays towards 24Vdc (with EDM activated) - Not connected > with EDM deactivated
0V	5	External 0Vdc
MAN/AUTO	6	- OSSD1 (7) > AUTOMATIC RESTART - OSSD2 (8) > MANUAL RESTART
OSSD1	7	Reel of external relay 1 (positive)
OSSD2	8	Reel of external relay 2 (positive)
RX1	9	PNP output of receiver photocell 1 (black)
RX2	10	PNP output of receiver photocell 2 (black)
RX3	11	PNP output of receiver photocell 3 (black)
RX4	12	PNP output of receiver photocell 4 (black)
TX1	13	TEST of emitter photocell 1 (black)
TX2	14	TEST of emitter photocell 2 (black)
TX3	15	TEST of emitter photocell 3 (black)
TX4	16	TEST of emitter photocell 4 (black)

# SG-BWS-T4-MT CONNECTIONS

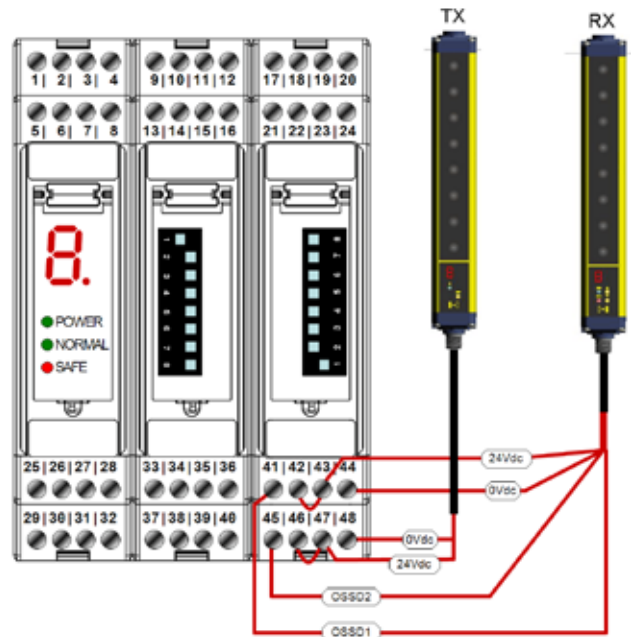
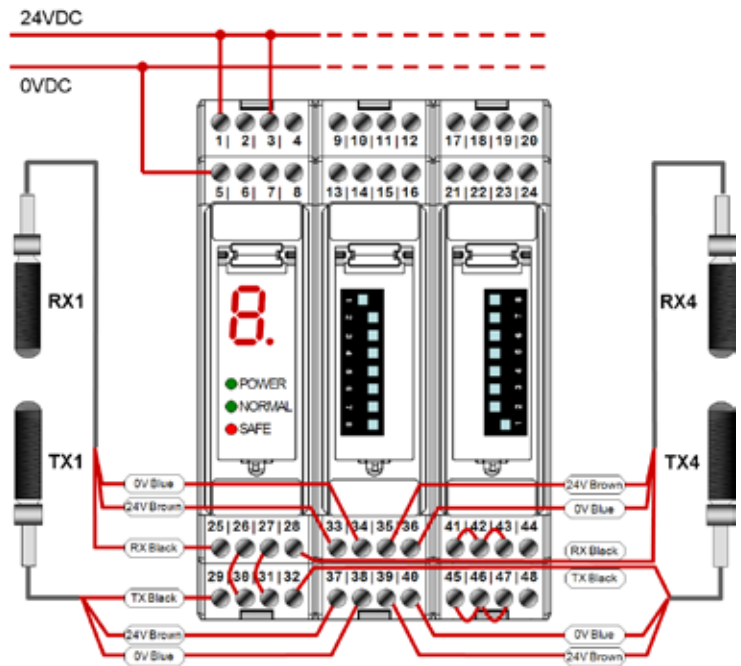
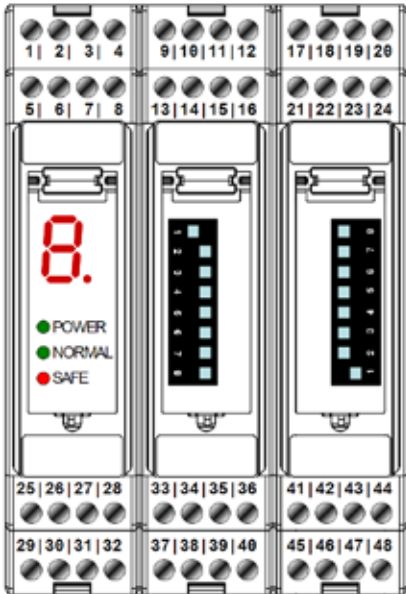

SIGNAL	CLAMP	CONNECTION	FUNCTION
VDC	1	External 24Vdc	Power supply
START	2	NO contact towards 24Vdc	Reset function
TEST/RESET	3	NC contact towards 24Vdc	Test/Reset function
EDM	4	- NC contact of external relays towards 24Vdc (with EDM activated) - NOT CONNECTED (with EDM deactivated)	Input EDM
0V	5	0Vdc external	Power supply
MUTEN A	6	NO contact towards 24Vdc	Muting activation
MUTEN B	7	NO contact towards 24Vdc	Muting activation
DEFLAMP	8	Positive terminal signaling device	Lamp fault signaling
MUTA1	9	PNP output of the A1 Muting sensor	Muting input
OVRA1	10	Contact of Override A1 NO towards 24Vdc	Override input
MUTB1	11	PNP output of the B1 Muting sensor	Muting input
OVRB1	12	Contact of Override B1 NO towards 24Vdc	Override input
MUTA2	13	PNP output of A2 Muting sensor	Muting input
OVRA2	14	Contact of Override A2 NO towards 24Vdc	Override input
MUTB2	15	PNP output of B2 Muting sensor	Muting input
OVRB2	16	Contact of Override B2 NO towards 24Vdc	Override input
LAMPA-	17	Negative terminal of the A Muting lamp	Muting lamp output
LAMPA+	18	Positive terminal of the A Muting lamp	Muting lamp output
SAFNC11	19	NO relay 230V 1 output	Safety contact
SAFNC21	20		Safety contact
LAMPB-	21	Negative terminal of the B Muting lamp	Muting lamp output
LAMPB+	22	Positive terminal of the B Muting lamp	Muting lamp output
SAFNC12	23	NO relay 230V 2 output	Safety contact
SAFNC22	24		Safety contact
RX1	25	PNP output of the photocell receiver 1 (black)	Photocell input
RX2	26	PNP output of the photocell receiver 2 (black)	Photocell input
RX3	27	PNP output of the photocell receiver 3 (black)	Photocell input
RX4	28	PNP output of the photocell receiver 4 (black)	Photocell input
TX1	29	TEST of the photocell emitter 1 (black)	Photocell output
TX2	30	TEST of the photocell emitter 2 (black)	Photocell output
TX3	31	TEST of the photocell emitter 1 3 (black)	Photocell output
TX4	32	TEST of the emitter photocell 4 (black)	Photocell output
24VRX12	33	24Vdc photocell receivers 1 and 2 (brown)	Power supply output
0VRX12	34	0 Vdc photocell receivers 1 and 2 (blue)	Power supply output
24VRX34	35	24 Vdc photocell receivers 3 and 4 (brown)	Power supply output
0VRX34	36	0Vdc photocell receivers 3 and 4 (blue)	Power supply output
24VTX12	37	24Vdc photocell emitters 1 and 2 (brown)	Power supply output
0VTX12	38	0Vdc photocell emitters 1 and 2 (blue)	Power supply output
24VTX34	39	24Vdc photocell emitters 3 and 4 (brown)	Power supply output
0VTX34	40	0Vdc photocell emitters 3 and 4 (blue)	Power supply output
OSSD11	41	OSSD 1 output of the light curtain 1 (grey)	Light curtain input
OSSD21	42	OSSD 1 output of the light curtain 2 (grey)	Light curtain input
24LRX12	43	24Vdc receivers of light curtain 1 and 2 (brown)	Power supply output
0LRX12	44	0Vdc receivers of light curtain 1 and 2 (brown)	Power supply output
OSSD12	45	OSSD 2 output of light curtain 1 (pink)	Light curtain input
OSSD22	46	OSSD 2 output of light curtain 2 (pink)	Light curtain input
24LTX12	47	24Vdc light curtain emitters 1 and 2 (brown)	Power supply output
0LTX12	48	0Vdc light curtain emitters 1 and 2 (brown)	Power supply output

NO: Normally open – NC: Normally closed

NOTE : Both SG-BWS-T4 and SG-BWS-T4-MT models are equipped with extractable screw clamps. It's possible to replace them with corresponding spring clamps provided as accessories, if necessary.

## TECHNICAL DATA

### ELECTRICAL DATA

	SG-BWS-T4	SG-BWS-T4-MT
Power supply:	24 Vdc ± 15%	24 Vdc ± 15%
Consumption:	2.1 W max	3.8 W max
Output contacts:	2 PNP	2 normally open relays, 250 Vac 5A - 24 Vdc 5A
Response time:	Short circuit protection: 1.4 A max	39ms (includes response time of photocells)
Safety category:	Type 4 (ref. EN 61496-1)	Type 4 (ref. EN 61496-1)
SIL:	SIL 3 (ref. IEC 61508 and IEC 62061)	SIL 3 (ref. IEC 61508 and IEC 62061)
PL:	PL e (ref. EN ISO 13849-1)	PL e (ref. EN ISO 13849-1)
PFHd min (1/h):	1,60E-09	1,74E-09
MTTFd (years):	545	428
Accessory functions:	Reset / EDM selection / auto-man selection	Reset / EDM selection / auto-man selection Single/Double Muting selection Edged/Triggered Override Selection
Overload protection:		Cat. II (250 Vac) – Cat. III (24Vdc) (ref. EN 50178)
Connections:	Clamps (*)	Clamps (*)
Cable lengths (power supply):	50 m. max	50 m. max
Pollution degree:	2	2

### MECHANICAL AND ENVIRONMENTAL DATA

Operating temperature:	0...55°C	0...55°C
Storage temperature:	-25...+ 70 °C	-25...+ 70 °C
Temperature class:	T6	T6
Humidity:	15...95 % (no condensation)	15...95 % (no condensation)
Mechanical protection:	IP 20 (EN 60529)	IP 20 (EN 60529)
Vibrations:	0.35 mm amplitude, 10 ... 55Hz frequency 20 sweeps for axis, 1octave/min (EN 60068-2-6)	0.35 mm amplitude, 10 ... 55Hz frequency 20 sweeps per axis, 1octave/min (EN 60068-2-6)
Shock resistance:	16 ms (10 G) 1.000 shocks for axis (EN 60068-2-29)	16 ms (10 G) 1.000 shocks for axis (EN 60068-2-29)
Housing material:	Nylon PA66	Nylon PA66
Weight:		

(\*) Spring clamps are available as accessories



## MODEL SELECTION TABLE

MODEL	DESCRIPTION	ORDER N°
SG-BWS-T4	cat. 4 safety control unit with edm and man/auto restart	957051000
SG-BWS-T4-MT	cat. 4 safety control unit with double muting	957051010

## ACCESSORY SELECTION AND ORDER INFORMATION

MODEL	DESCRIPTION	ORDER N°
SG-DM 150	deviating mirror h=150mm	95ASE1670
LMS	muting lamp	95ASE1830
LMS-1	modular muting lamp	95ACC1990
LMS-2	muting lamp – horizontal mounting	95ACC2000
LMS-3	muting lamp - vertical mounting	95ACC2010
SU-LMS-1A	base module for lms-1	95ACC2020
SU-LMS-1B	tower module for lms-1	95ACC2030



The company endeavours to continuously improve and renew its products; for this reason the technical data and contents of this catalogue may undergo variations without prior notice. For correct installation and use, the company can guarantee only the data indicated in the instruction manual supplied with the products.