



INSTRUCTION MANUAL

CONTROLS

OUTPUT LED (yellow)
The yellow LED ON indicates the output status.

READY LED (green)
The green LED ON indicates the powering status.

SET PUSH-BUTTON
A long pressure on the push-button activates the teach procedure. The REMOTE input allows the external control of the SET push-button.

DARK/LIGHT TRIMMER
The light/dark mode is selected by a monoturn trimmer.

Please refer to the "SETTING" paragraph to get the correct setting procedure.
WARNING: the maximum mechanical rotation range of the trimmer is 240°. Do not force over of the maximum and minimum positions.

INSTALLATION

S8-PR:
The sensor can be positioned by means of the two housing holes using two screws (M3x18 or longer, 0.8Nm maximum tightening torque) with washers.

S8-MR:
The sensor can be positioned by means of the two threaded holes using two screws (M3x14 or longer, 0.8Nm maximum tightening torque) with washers.

Various orientable fixing brackets to ease the sensor positioning are available (please refer to the accessories listed in the general catalogue). The operating distance is measured from the front surface of the sensor optics.

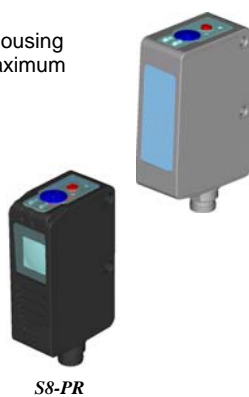

CONNECTIONS

M8 connector

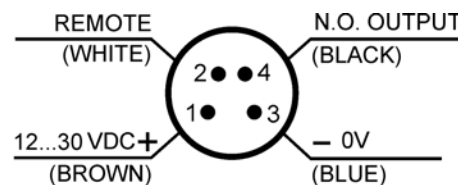

Pig-tail with M12 connector

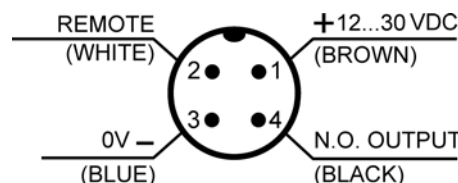

TECHNICAL DATA

Power supply:	12 ... 30 VDC Class 2 (Type 1 for S8-MR) UL508
Ripple:	2 Vpp max.
Current consumption (output current excluded):	30 mA max
Outputs:	PNP or NPN N.O.; 30 VDC max. (short-circuit protection) Pull-down/up resistance = 47 KΩ
Output current:	100 mA (overload protection)
Output saturation voltage:	≤ 2 V
Response time:	250 μs / 1 ms
Switching frequency:	500Hz / 2 kHz (according to sensitivity)
Emission type:	LED UV (375 nm)
Spot dimension:	∅ 2 mm a 15 mm
Operating distance (typical values):	10...30 mm
LIGHT/DARK selection:	Mono-turn trimmer
Indicators:	OUTPUT LED (YELLOW) / READY LED (GREEN)
Operating temperature:	-10 ... 55 °C
Storage temperature:	-20 ... 70 °C
Dielectric strength:	□: 1500 VAC 1 min. between electronics and housing
Insulating resistance:	>20 MΩ 500 Vdc between electronics and housing
Ambient light rejection:	according to EN 60947-5-2
Vibrations:	0.5 mm amplitude, 10 ... 55 Hz frequency, for each axis (EN60068-2-6)
Shock resistance:	11 ms (30 G) 6 shocks for each axis (EN60068-2-27)
Housing material:	ABS (S8-PR) / INOX AISI 316L (S8-MR)
Lens material:	Window in glass; lens in PC (S8-PR) / window in PMMA (S8-MR)
Mechanical protection:	IP67 (S8-PR) / IP67, IP69K (S8-MR)
Connections:	M8 4-pole connector / 150 mm ∅ 4 mm cable with M12 4-pole connector (S8-PR pig-tail vers.)
Weight:	12 g. max. (S8-PR connector vers.) / 50 g. max. pig-tail (S8-PR pig-tail vers.) 70 g. max (S8-MR connector vers.)

SETTINGS

LIGHT/DARK MODE SETTING

LIGHT mode setting
Rotate trimmer in an anti-clockwise direction to set the LIGHT mode (output ON on fluorescent mark).

DARK mode setting
Rotate trimmer in a clockwise direction to set the DARK mode (output ON on background).

EASY TOUCH ACQUISITION

Place mark in front of the sensor spot and press SET until the green READY LED turns off.

If the READY LED turns permanently ON the acquisition was successful.
If the LED blinks slowly the acquisition failed due to insufficient signal.

Press SET and the sensor returns to the previous setting.
If the Easy Touch acquisition fails due to insufficient signal, try using Mark-Background procedure described below.

MARK-BACKGROUND ACQUISITION

Mark acquisition
Place mark in front of the sensor spot and press SET until the green READY LED turns on again (3 sec).

Background acquisition
Place background in front of the sensor spot and press SET again.

If the READY LED turns permanently ON the acquisition was successful.
If the LED blinks slowly the acquisition failed due to insufficient contrast.
Press SET and the sensor returns to the previous setting.

During detection if the luminescence is very low, the sensor increase his sensitivity with a frequency of 500Hz (LED READY green blinks two times at the end of teach procedure).

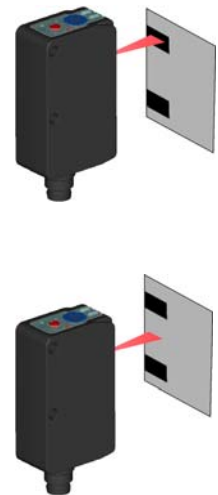
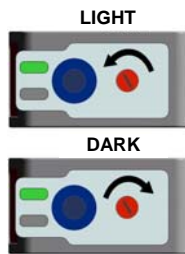

OTHER FUNCTIONS

MAXIMUM SENSITIVITY WITH MAXIMUM FREQUENCY SETTING

To set maximum sensitivity with maximum frequency, press SET push-button for 5 sec. with LED READY green turns off again.

REMOTE INPUT

The REMOTE signal carries-out acquisition functions without using the SET push-button.
The REMOTE wire connected to +VDC is equal to pressing the SET push-button, connected to GND or not connected is equal to not pressing the SET push-button.

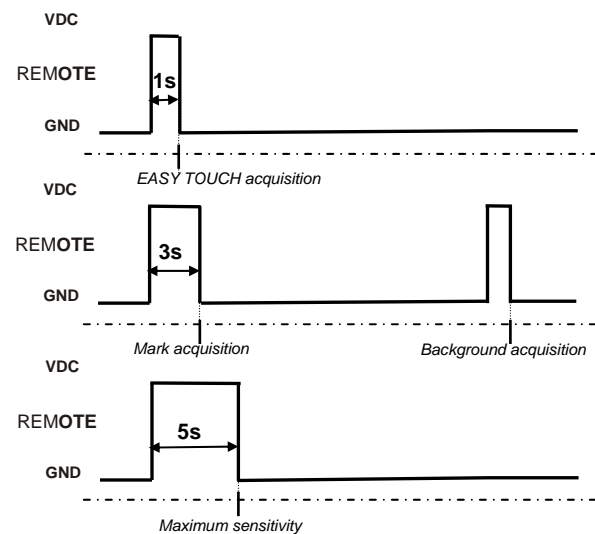

DIMENSIONS

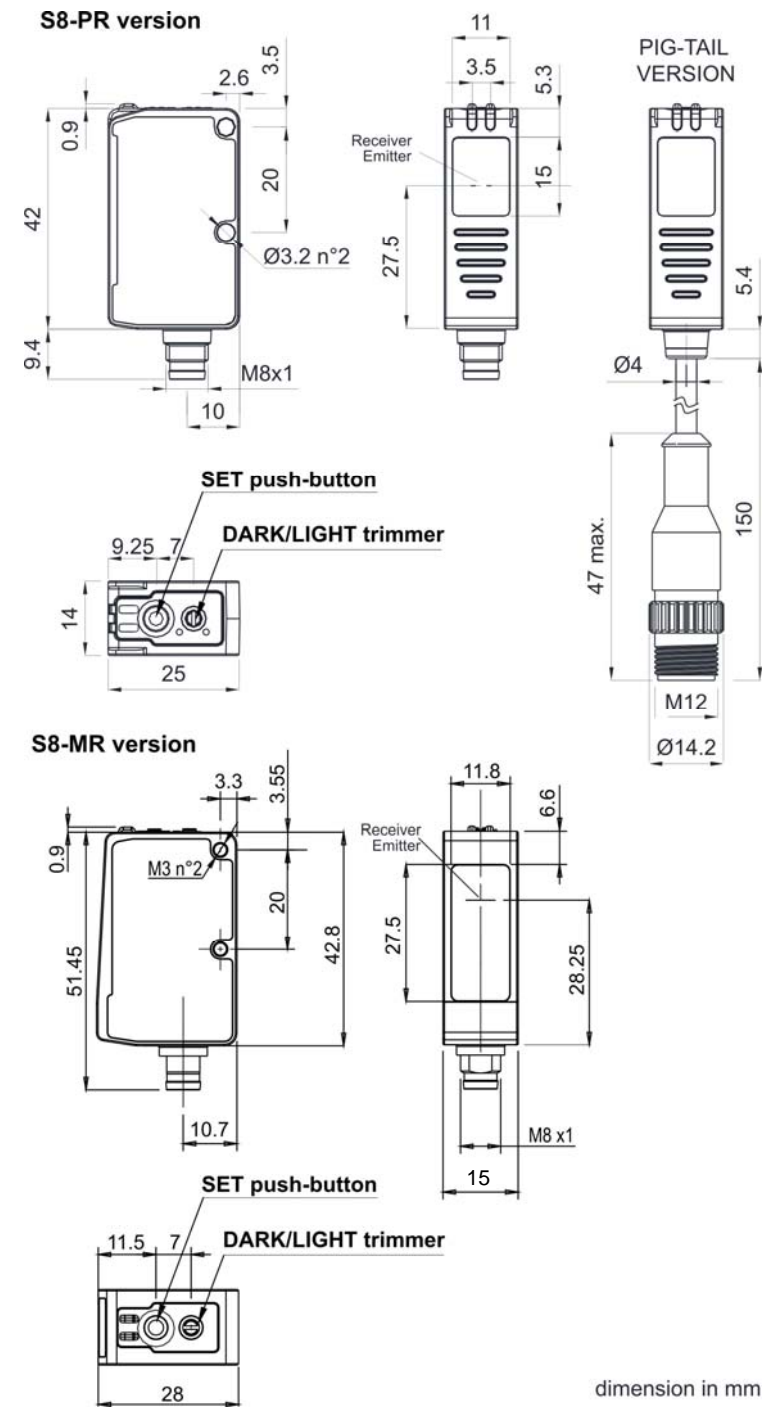

The sensors are NOT safety devices, and so MUST NOT be used in the safety control of the machines where installed.

DECLARATION OF CONFORMITY

We Datalogic Automation declare under our sole responsibility that these products are conform to the 2004/108/CE and successive amendments.

WARRANTY

Datalogic Automation warrants its products to be free from defects. Datalogic Automation will repair or replace, free of charge, any product found to be defective during the warranty period of 36 months from the manufacturing date. This warranty does not cover damage or liability deriving from the improper application of Datalogic Automation products.

DATALOGIC AUTOMATION srl

Via Lavino 265 - 40050 Monte S.Pietro - Bologna - Italy
Tel: +39 051 6765611 - Fax: +39 051 6759324 www.datalogic.com

DATALOGIC AUTOMATION cares for the environment: 100% recycled paper.
DATALOGIC AUTOMATION reserves the right to make modifications and improvements without prior notification.

© 2013 Datalogic Automation - ALL RIGHTS RESERVED - Protected to the fullest extent under U.S. and international laws. Copying, or altering of this document is prohibited without express written consent from Datalogic Automation. Datalogic and the Datalogic logo are registered trademarks of Datalogic S.p.A. in many countries, including the U.S.A. and the E.U.