

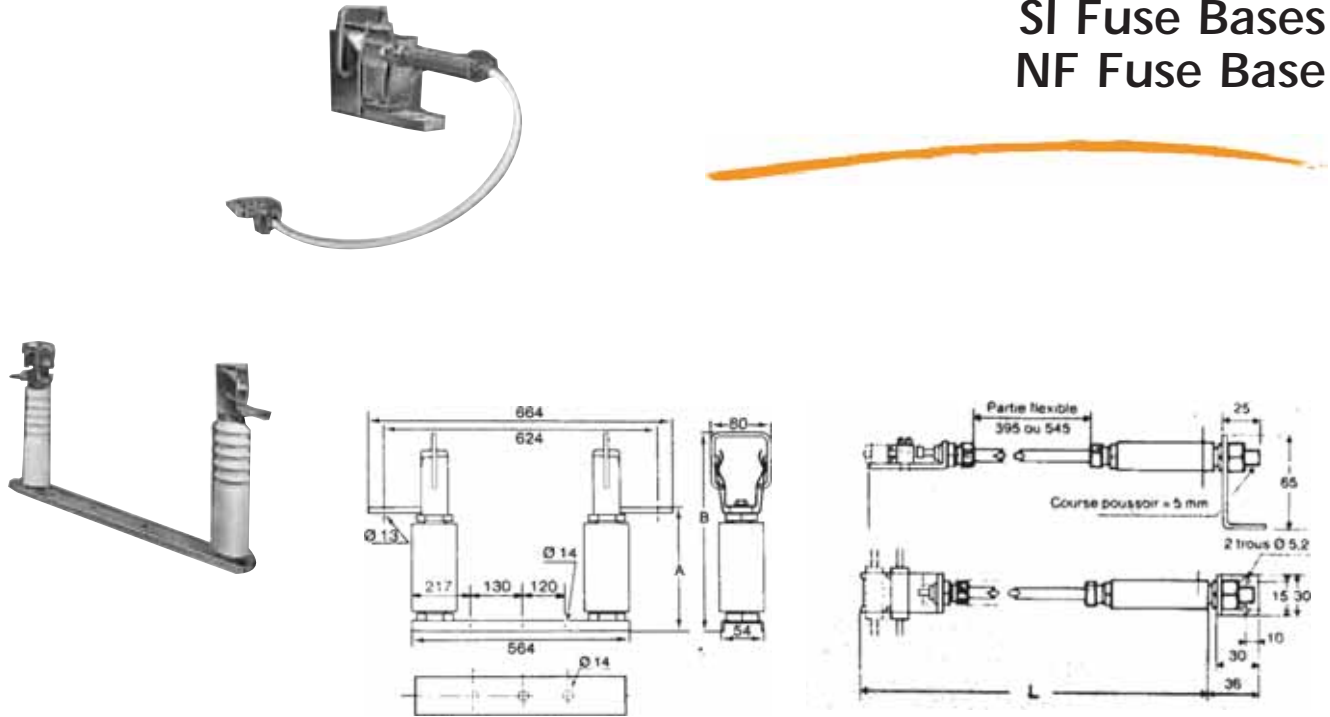

Medium Voltage Fuses SI Fuse Bases NF Fuse Base



Fuse-holder

Rated voltage (kV)	Designation	Reference Number	Ground voltage withstand		A (mm)	B (mm)	Weight (kg)	Catalog Number
			50 Hz - 1 mn (RMS)	1,2/50µS (peak)				
7,2	SI 120 55x520	K092354	27	60	161	260	2.8	SI130-55-520
12/17,5	SI 175 55x520	Q092934	45	95	216	315	3.6	SI175-55-520
24	SI 225 55x520	R092935	55	125	266	365	4.8	SI210-55-520
36	SI 310 55x520	L092355	75	170	351	450	6.8	SI300-55-520

Indicating device

Rated voltage of corresponding fuse-holder (kV)	Designation	Reference Number	Number of Microswitches	Length of flexible part	L (mm)	Weight (kg)	Catalog Number
7,2	MC 1-5 FlexQ	E092694	1	395	560	0,205	MC1-5NFLEXQ
7,2	MC 1-9 FlexQ	F092695	2	395	560	0,215	MC1-9NFLEXQ
12 to 36	MC 1-5 FlexQ640	T092615	1	545	710	0,220	MC1-5NFLEXQ640
12 to 36	MC 1-9 FlexQ640	K078945	2	545	710	0,230	MC1-9NFLEXQ640

The indicating device enables electrical actuating of the opening mechanism for a circuit or triggering of an indicator during the melting of a fuse equipped with a trip-indicator. This very robust and original device means freedom for any mechanical system and offers the advantage of being able to incorporate a microswitch unit or units according to the equipment configuration.