

Over Voltage Protector

CPS polarized
type PSPL,

CPS non-polarized
type PSNP.



OVER VOLTAGE PROTECTOR

For overvoltage protection LENOIR ELEC has developed a new device : the CPS.

This is a device whose original concept gives it very interesting characteristics i.e. :

- precision,
- speed,
- high energy transfer,
- firing on 1 polarity of the voltage or 2,
- firing voltage adjustable (pre-set in factory/low or high),
- visual indication of operation,
- remote signalling by microswitch (option),
- manual re-set after operation.

In certain countries, standards exist for the protection of personnel when voltages higher than 50 V or 100 V appear at accessible points.

The device can be used on both AC and DC circuits.

The object of the device is to short circuit 2 points in a network or apparatus when the voltage difference between these 2 points has reached a dangerous value.

Metal catenary structures

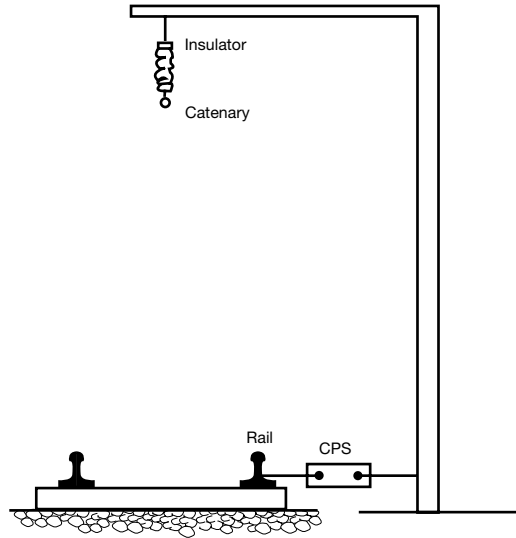

A dangerous voltage can appear on these structures if the insulator breaks down between the catenary wire and its support. In order to eliminate circumstances which could pose a threat to personnel, the device is connected between the support and rail. When the support point rises above a certain level, it is short circuited to the rail and provokes protection to operate.

IMPORTANT :

Often under normal conditions, the potential of the rail is higher than that of the support structures by an amount up to about 250 V.

The operation of the overvoltage device is not desirable under these circumstances, and a polarized type can be used which will only trigger when the potential of the structure is higher by 100 volts than that of the rail, and not when the reverse is the case e.g. if the cable falls to the rail.

Level crossing gates

It can happen under certain circumstances of insulation break down that a dangerous potential can appear at these gates. To avoid this danger it is sufficient to connect the device between the gate and the rail.

Protection of electrical installations providing cathodic protection

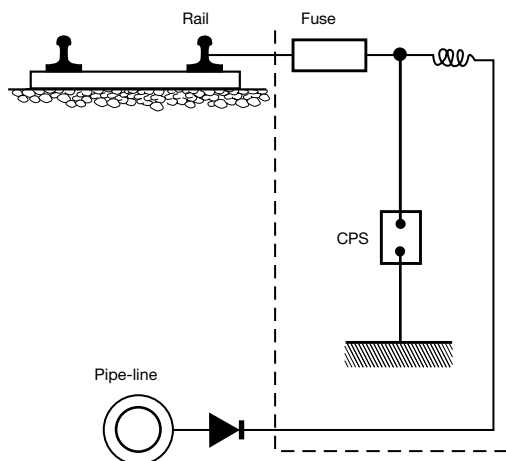

In some transit systems metal drain pipes are installed running along side the rail, and there are electrical installations to provided cathodic protection against electrolyse corrosion. This results in a difference of potential between the piping and ground.

The polarized electrical installation keeps the potential of the piping at a level lower than that of ground by connection to the negative (rail). If, however, a fault should raise the voltage of the rail to a dangerously high level, the cathodic protection system can be damaged, and the piping is no longer protected. This can be avoided by connecting the CPS device as shown and putting a fuse in the circuit. The firing of the CPS creates a short circuit which blows the fuse leaving the cathodic protection system isolated from the rail and protected until the fault is eliminated.

Negative rail and ground (D.C. traction)

To minimise the corrosive effects of stray currents, the negative rail is insulated from ground. This results in variations in potential between the negative rail and ground.

To protect against an excessive potential on the negative rail, the device can be placed between ground and the negative rail, and as in the application in para. : «metal catenary structures», a polarized model is preferred because it will direct the energy flow from the rail to ground.

Protection of electronic equipment

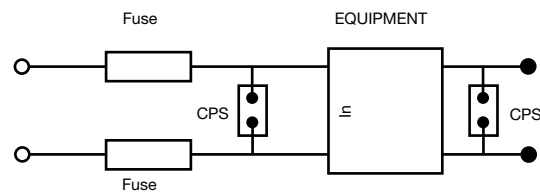

More and more electronic equipment is becoming exposed to less than usual environments (e.g. automatic control of trains and subways).

This equipment can become damaged by overvoltages. An example could be the accidental contact between a communication cable and a rail, or lightning which could damage a computer. Different examples are numerous.

To protect electronic equipment it is sufficient to install a CPS device between the input terminals (or output). If an overvoltage occurs, the device short circuits the terminals, and causes the fuse to blow and isolate the equipment.

Insulation failure

Where high voltages appear on low voltage windings this device can be connected between the neutral and ground. When the neutral point rises above certain level it is short circuited to ground and provokes protection to operate.

Over Voltage Protector Principle

The CPS device is made up of 2 parallel circuits :

- ① an electronic and electro-magnetic circuit
- ② a mechanical short circuiter circuit.

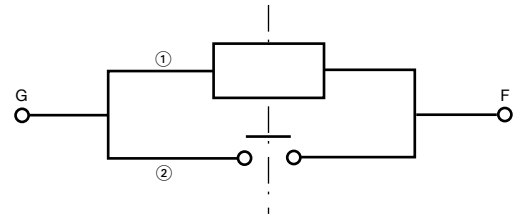

Roles of electronic and electro-magnetic circuit

- gives a rapid response time to connect G and F in 3 micro-seconds through the actuating circuit. The electro-mechanical energy required to establish the main short circuit is such that a longer time is required, and thus transients will not cause nuisance operation,
- is versatile in as much that either pole can be selected as the datum with respect to the other,
- when the fault has sufficient energy, the electro-magnetic circuit triggers the mechanical short circuiter to provoke clearance by the main circuit breaking apparatus.

Roles of the mechanical short-circuiter

- to establish a definite short-circuit between G and F when the fault has sufficient energy. When the fault has been cleared and rectified, the CPS device is re-armed manually to its initial open position,
- to provide high energy transfer.

NOTA : The last remark shows that a large enough current is going through the CPS to trigger a circuit breaker or to melt a fuse.

REMARKS :

It is mentioned above that the CPS device can create a short circuit when the voltage rises on either pole relative to the other, and for that reason there are actually 2 devices :

- Polarized type PSPL
- Non-polarized type PSNP

Over Voltage Protector Description and dimensions

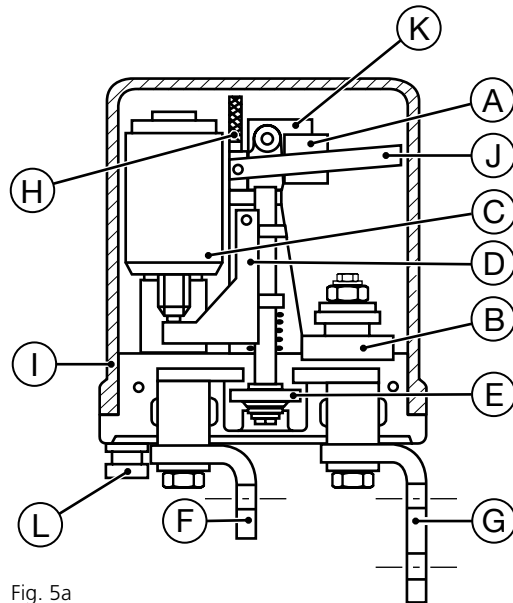

Fig. 5a

- A Electronic control
- B Thyristor
- C Electro magnet
- D Latch
- E Power contacts
- F Main pole
- G Main pole
- H Visual indicator
- I Cover
- J Reset lever
- K Micro switch
- L Micro switch connectors

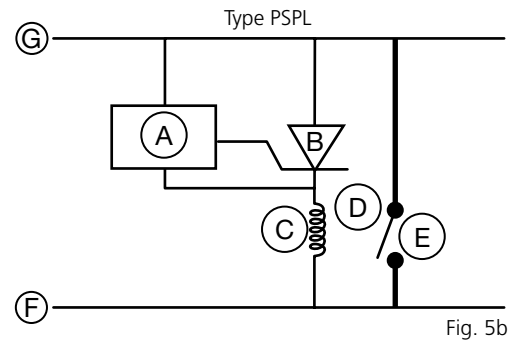

Fig. 5b

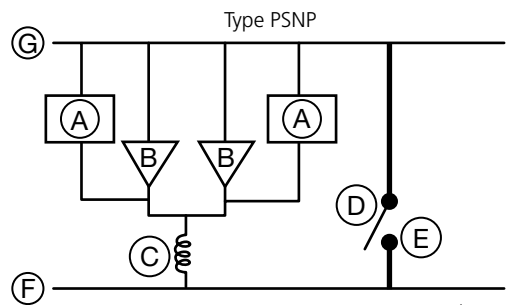
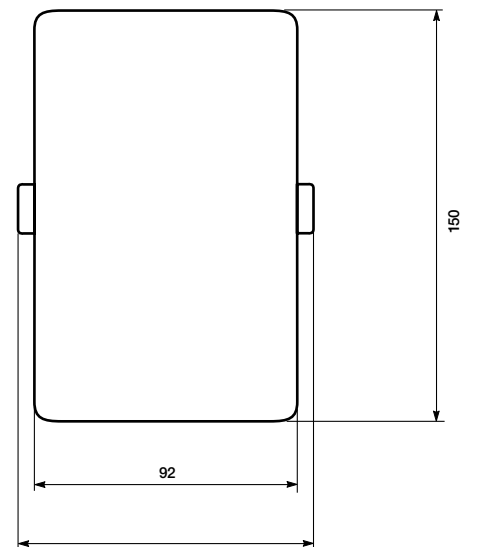
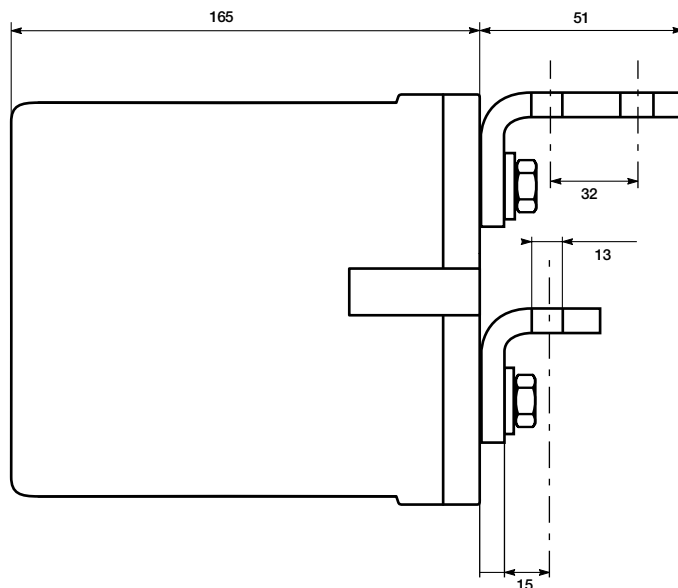

Fig. 5c

Devices PSPL and PSNP have the same dimensions as shown on fig. 5a.

Figures 5b and 5c give the electrical schematics, illustrating the main difference between the two devices. These show why PSPL triggers only if the potential at G is high with respect to F, whereas PSNP will trigger on preset overvoltages whatever they are with respect to each other.



This includes the operation of non-polarized type PSNP and polarized type PSPL as soon as the preset voltage is reached. When the voltage between G and F reaches that level V_d , the detection circuit sends the firing signal to the gates of thyristors B. At this instant the thyristor fires and the voltage limit is already assured.

There are 2 possibilities :

- CASE 1 : If the fault energy is too low only the electronic and electro-magnetic will be excited (fig. 6a, 6b, 6c) and when the current passing through the device comes back to zero, the device remains in its initial position with the thyristor(s) blocked.
- CASE 2 : If the fault energy is large enough, the short circuit is activated by electro magnet (C) via the mechanical latch (D). The short circuit contact (E) closes and establishes a definite short circuit between G and F (see fig. 7a, 7b and 7c). The short circuit current fault is then interrupted by a circuit breaker or a fuse. Visual indicator H shows that the device has operated and remote signalling is also possible by a micro switch system K giving an output L. To reset the device it is necessary to take off the cover I and pull on the re-arming lever J.

Figures 6a and 7a represent the voltage V between points G and F where an overvoltage protector is not installed. Curves 6b and 7b represent the voltage between points G and F when an overvoltage protector is installed. 6c and 7c represent the current I_P flow through the device.

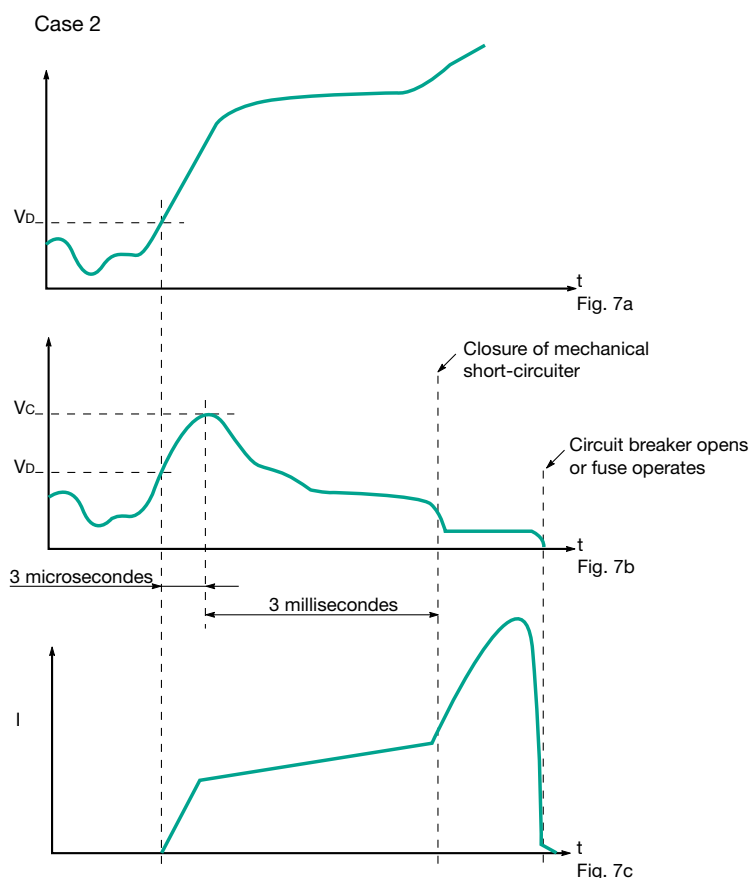
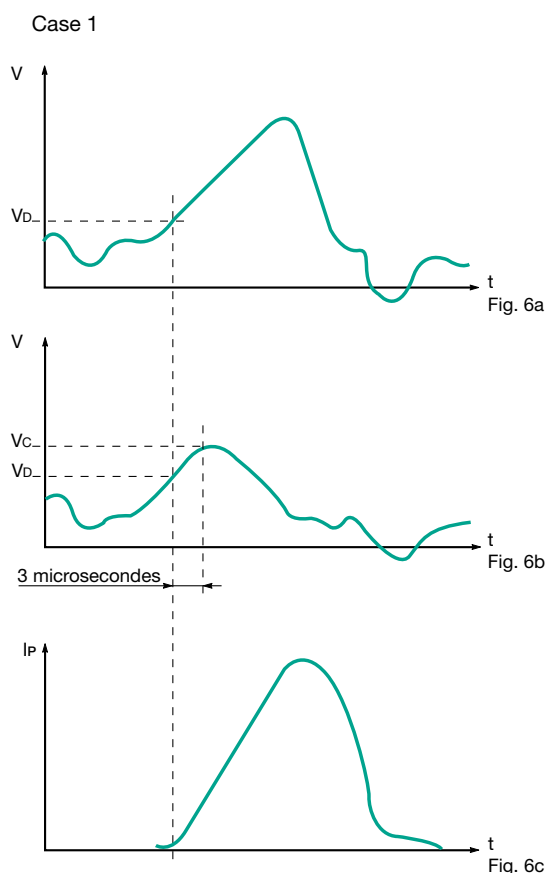

Over Voltage Protector

Electrical characteristics

		TYPE OF DEVICE	
		PSPL	PSNP
V _D voltage for certain firing (1)	to 1 000 V - V _D	15	15
Minimum firing voltage (1)	V _D	0,7	0,7
Response time in micro-seconds		3	3
RMS value of allowable current I _p as a function of time	0,3 s	15 000 A	
	10 s	4 000 A	
	42 s	2 000 A	
	25 mn continuous	1 000 A 750 A	
V _C peak cut-off voltage		V _C = V _D + 3 dV/dt with V _D in volts and dV/dt in volts/microsecond	
Reverse continuous voltage (2)	V	400 to 2 000	
Leakage current at 2 000 V	mA	30	30
Time to close short circuiter E	ms	3	3
Critical dV/dt of thyristor	V/μs	300	300

(1) There is a tolerance on the value of this voltage. The maximum value is V_D and the minimum value is 0,7 V_D, therefore the device will always function at V_D.

(2) This value is only interesting for the polarized device to be operated when the voltage of G is greater than that of F. It will trigger only for one polarity starting at 15 V difference of potential (G and F). In the reverse direction it will not trigger up to 2 000 V (function of the thyristor).

Non-polarized over voltage protector type PSNP

Tripping voltage (V)	Reverse tripping voltage (V)	Micro-switch	Temporization	Designation	Product code
200	200	2 MC	NON	PSPN 02C-02C-2MC	PQ206186A
100	100	MC	NON	PSPN 01C-01C-MC	PA203481A
100	400	MC	NON	PSPN 01C-04C-MC	PF209259A
100	70	MC	NON	PSPN 01C-07D-MC	PF092948A
200	400	MC	NON	PSPN 02C-04C-MC	PA091977A
50	50		NON	PSPN 05D-05D	PV077022A
50	50	2 MC	OUI	PSPN 05D-05D+2MC+TEMPO	PK209700A
50	50	MC	NON	PSPN 05D-05D-MC	PJ093595A
50	50	MCSP	NON	PSPN 05D-05D-MCSP	PY205135A
150	150	MC	NON	PSPN 15D-15D-MC	PH209583A

Polarized over voltage protector type PSPL

Tripping voltage (V)	Reverse hold voltage(V)	Micro-switch	Temporization	Designation	Product code
50	400	MC	NON	PSPL 05D-04C-MC-RD ⁽¹⁾	PA205712A
100	400		NON	PSPL 01C-04C	PC092922A
100	400	MC	NON	PSPL 01C-04C-MC	PE092947A
100	800	MC	NON	PSPL 01C-08C-MC-RD ⁽¹⁾ 220V	PK206411A
100	800	MC	NON	PSPL 01C-08C-MC	PC094532A
200	800	MC	NON	PSPL 02C-08C-MC	PB091978A
200	800	2 MC	NON	PSPL 02C-08C-2MC	PQ207014A
300	800		NON	PSPL 03C-08C	PX202903A
300	800	MC	NON	PSPL 03C-08C-MC	PS203382A
400	800	MC	NON	PSPL 04C-08C-MC	PS202002A
50	400	MC	NON	PSPL 05D-04C-MC	PF081540A
50	400	2 MC	NON	PSPL 05D-04C-2MC	PF093523A
60	800	MC	NON	PSPL 06D-08C-MC	PF083863A
700	800	MC	NON	PSPL 07C-08C-MC	PM093529A
80	800	MC	NON	PSPL 08D-08C-MC	PH098355A
50	800	MC	NON	PSPL 05D-08C-MC	PF083800A
150	400	MC	NON	PSPL 15D-04C-MC	PG092351A
250	800	MC	NON	PSPL 25D-08C-MC	PM206551A

(1) relay remote re-set possible.

Nota : other values and types, please consult with us.