



S62-PL...B Laser

Polarised retroreflex



S62-PL...C Laser

Diffuse proximity

INSTRUCTION MANUAL



CONTROLS

OUTPUT LED (yellow)

The yellow LED ON indicates the following output status: N.O. closed and N.C. open.

POWER ON LED (green)

The green LED ON indicates the sensor powering status and laser emission presence.

SENSITIVITY TRIMMER (ADJ.)

Monoturn trimmer that adjusts the sensitivity and thus the sensor operating distance. Please refer to "SETTING" paragraph for the correct use procedure.

WARNING: the maximum mechanical trimmer rotation is equal to 240°. Do not apply excessive torque over the maximum and minimum positions.

INSTALLATION

The sensor can be positioned by means of the three housing's holes using two screws (M4x25 or longer, 1.5 Nm maximum tightening torque) with washers. Various orientable fixing brackets to ease the sensor positioning are available (please refer to the accessories listed in the general catalogue). The operating distance is measured from the front surface of the sensor optics. The M12 connector can be oriented at two different positions using the specific fastening spring and rotating the block to 180°.



CONNECTIONS

M12 connector

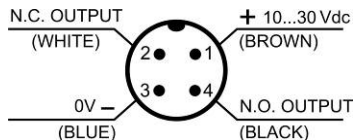

TECHNICAL DATA

	S62..B	S62..C
Power supply:	10 ... 30 Vcc	
Ripple:	2 Vpp max.	
Consumption (output current excluded):	30 mA max	
Outputs:	PNP or NPN N.O. / N.C.; 30 Vdc max. (short-circuit protection)	
Output current:	100 mA max (overload and overvoltage protection)	
Output saturation voltage:	≤ 2 V	
Response time:	200 μs	
Switching frequency:	2.5 kHz	
Emission type:	RED LASER (λ = 645...665 nm): Class 2 EN 60825-1, Class II CDRH 21 CFR PART 1040.10 Pulsed emission: pot. max ≤ 5 mW; pulse duration = 5 μs; frequency max = 32 KHz	
Operating distance (typical values):	refer to TAB.1	1m on 90% white target (EG2)
Min. detectable object dimension:	0.5 mm at 0.5m (minimum spot)	
Indicators:	OUTPUT LED (YELLOW) / POWER ON LED (GREEN)	
Setting:	Monoturn sensitivity adjustment trimmer	
Functioning temperature:	-10 ... 55 °C	
Storage temperature:	-20 ... 70 °C	
Dielectric strength:	500 Vac 1 min., between electronics and housing	
Insulating resistance:	>20 MΩ 500 Vdc, between electronics and housing	
Ambient light rejection:	according to EN 60947-5-2	
Vibrations:	0.5 mm amplitude, 10 ... 55 Hz frequency, for every axis (EN60068-2-6)	
Shock resistance:	11 ms (30 G) 6 shock for every axis (EN60068-2-27)	
Housing material:	ABS	
Lens material:	PMMA window, polycarbonate lenses	
Mechanical protection:	IP67	
Connections:	M12 4-pole connector	
Weight:	40 g. max.	

S62...B SETTING

S62...B alignment:

- Position the sensor and reflector aligned on opposite sides at the desired distance.
- Turn to maximum the sensitivity adjustment trimmer (ADJ.) (clockwise).

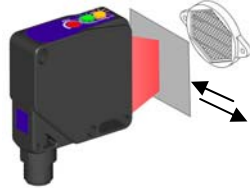

- Determine the powering on and powering off points of the yellow LED (OUT) by moving vertically and horizontally the sensor and mount the sensor in the middle of the points found.

Control:

- Enter laterally the object inside the operating field and control that the yellow LED turns on.
- Remove the object and check that the yellow LED turns off immediately

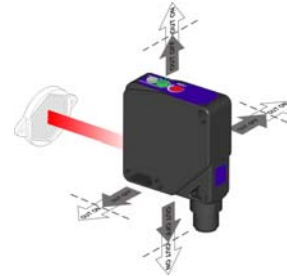

S62...C setting:

Position the sensor and turn the sensitivity trimmer at minimum: the yellow LED is OFF. Place the target opposite the sensor.

Turn the sensitivity trimmer clockwise until the yellow LED turns ON (Target detected state, pos.A).

Remove the target, the yellow LED turns OFF. Turn the trimmer clockwise until the yellow LED turns ON (Background detected state, pos.B). The trimmer reaches maximum if the background is not detected.

Turn the trimmer in intermediate position C, between the two positions A and B. The green LED must be ON.

S62...B PERFORMANCES

TAB.1: Operating distances (m)

REFLECTOR (mm)				
R1 (Ø31)	R2 (Ø63)	R6 (60x40)	R7 (51x51) R20 (Ø63)	R8 (19x10)
0.3 ... 16	0.3 ... 20	0.4 ... 22	0.3 ... 22	0.2 ... 2

Note: The use of the RT 3970 reflecting tape is not suggested.

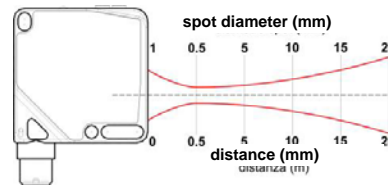

DIMENSIONS

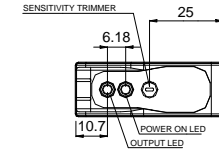
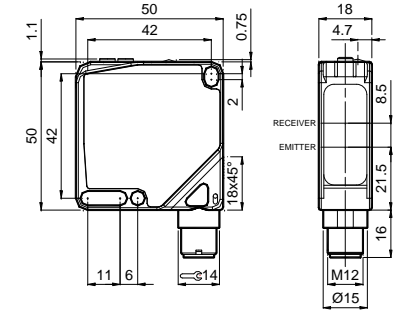

SAFETY PRECAUTIONS

All the electric and mechanical safety regulations have to be respected during sensor functioning. The sensor has to be protected against mechanical damage. Apply the labels supplied in a visible position near the laser emission beam.



Do not stare directly into the laser beam!
Do not point the laser beam towards people!
Eye irradiation superior to 0.25 seconds is dangerous. Please refer to the Class 2 Standard (EN60825-1). These sensors can not be used for safety applications!

The sensors are NOT safety devices, and so MUST NOT be used in the safety control of the machines where installed.

DECLARATION OF CONFORMITY

We Datalogic Automation declare under our sole responsibility that these products are conform to the 2004/108/CE and successive amendments.



WARRANTY

Datalogic Automation warrants its products to be free from defects. Datalogic Automation will repair or replace, free of charge, any product found to be defective during the warranty period of 36 months from the manufacturing date. This warranty does not cover damage or liability deriving from the improper application of Datalogic Automation products.

DATALOGIC AUTOMATION

Via Lavino 265 - 40050 Monte S.Pietro - Bologna - Italy
Tel: +39 051 6765611 - Fax: +39 051 6759324
www.automation.datalogic.com e-mail: info.automation.it@datalogic.com

DATALOGIC AUTOMATION cares for the environment: 100% recycled paper. DATALOGIC AUTOMATION reserves the right to make modifications and improvements without prior notification.

© 2008 - 2012 Datalogic Automation - ALL RIGHTS RESERVED - Protected to the fullest extent under U.S. and international laws. Copying, or altering of this document is prohibited without express written consent from Datalogic Automation. Datalogic and the Datalogic logo are registered trademarks of Datalogic S.p.A. in many countries, including the U.S.A. and the E.U.