



QLM700

INSTALLATION MANUAL

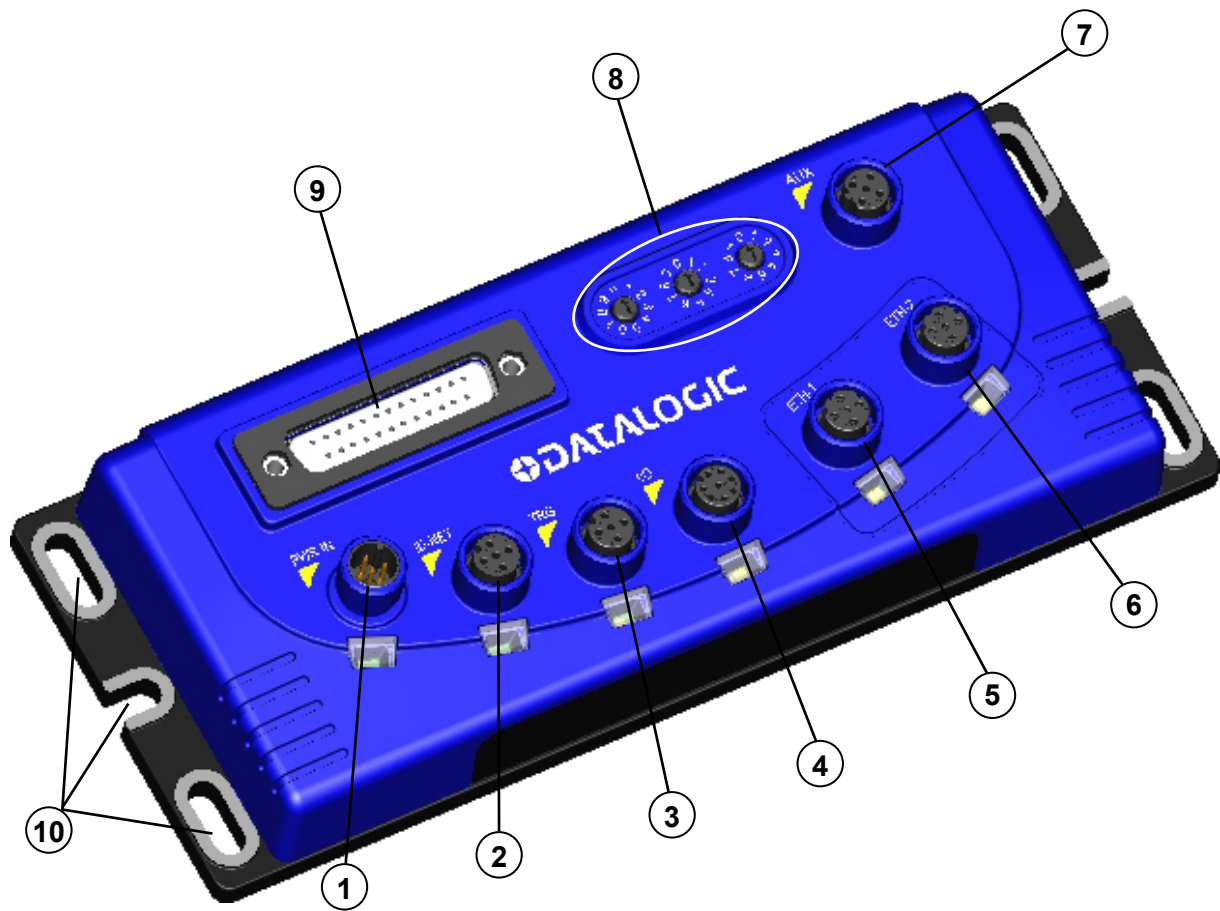

Figure A

- | | | | |
|---|--------------------------------------|----|--------------------------------------|
| 1 | Power In Connector and LED | 6 | Profinet IO Port 2 Connector and LED |
| 2 | ID-NET Connector and LED | 7 | Auxiliary Port Connector |
| 3 | Trigger Connector and LED | 8 | IP Address Selectors (last octet) |
| 4 | I/O Connector and LED | 9 | Reading Device Connector |
| 5 | Profinet IO Port 1 Connector and LED | 10 | Mounting slots (6) |

UPDATES AVAILABILITY

- UK/US** The latest documentation updates for this product are available on Internet.
Log on to: www.automation.datalogic.com
- I** Su Internet sono disponibili le versioni aggiornate di documentazione di questo prodotto.
Collegarsi a: www.automation.datalogic.com
- F** Les versions mises à jour de documentation de ce produit sont disponibles sur Internet.
Cliquez sur : www.automation.datalogic.com
- D** Im Internet finden Sie die aktuellsten Versionen der Dokumentation von diesem Produkt.
Adresse : www.automation.datalogic.com
- E** En Internet están disponibles las versiones actualizadas de la documentación de este producto.
Dirección Internet : www.automation.datalogic.com

SERVICES AND SUPPORT

Datalogic provides several services as well as technical support through its website. Log on to www.automation.datalogic.com and click on the [links](#) indicated for further information including:

- **PRODUCTS**

Search through the links to arrive at your product page which describes specific Info, Features, Applications, Models, Accessories, and Downloads including the [Genius™](#) utility program, which allows device configuration using a PC. It provides RS232 and Ethernet interface configuration.

- **SERVICE**

- **Overview** - Warranty Extensions and Maintenance Agreements
- **Sales Network**- Listing of Subsidiaries, Repair Centers, Partners
- **Helpdesk**
- **Material Return Authorization**

LEGAL NOTICES

© 2012 Datalogic Automation S.r.l. ♦ ALL RIGHTS RESERVED. ♦ Protected to the fullest extent under U.S. and international laws. Copying, or altering of this document is prohibited without express written consent from Datalogic Automation S.r.l.

Datalogic and the Datalogic logo are registered trademarks of Datalogic S.p.A. in many countries, including the U.S.A. and the E.U.

ID-NET, and Genius are trademarks of Datalogic Automation S.r.l. All other brand and product names mentioned herein are for identification purposes only and may be trademarks or registered trademarks of their respective owners.

Datalogic shall not be liable for technical or editorial errors or omissions contained herein, nor for incidental or consequential damages resulting from the use of this material.

DESCRIPTION

The QLM700 Profinet IO Gateway is an active connection module which can be used in Standalone or ID-NET™ Master Multidata, or Master Synchronized layouts. It provides a fast and efficient way to cable both an Profinet IO network and an ID-NET™ network using standard cables.

It provides separate M12 connectors for Power Supply, Profinet Communication, ID-NET™ Network, External Trigger, Digital I/O and Aux RS232 Communication for configuration of the reading device.

The QLM700 Gateway provides an easy way to connect many Datalogic reading devices to any PLC with Profinet IO support. It allows Profinet IO real-time communication with bus topologies, and due to its two Profinet ports, it eliminates the need for expensive external switches.

Host communication is provided through the integrated Profinet IO circuitry which connects internally to the reader's Main serial interface (RS232).

ID-NET™ network and power supply signals are provided to the next connected device (ID-NET™ Slave), by means of a dedicated M12 connector. However there is not a second ID-NET™ network connector for bus propagation and therefore the QLM700 cannot be used as an ID-NET™ Slave.

The reading device is connected to the QLM700 through a standard 25-pin D-sub connector.

Three rotary switches allow easy manual Network Addressing selection.

The following accessories make system cabling easy:

- CBL-1487 connector or CS-A2-02-G-xx cable, to build the Power Supply connection.
- FMC600 connector, to build the I/O connections.
- CAB-AUX03 cable, to connect the Gateway to a PC to configure the connected reading device.
- CBL-1480-xx cable, to build the ID-NET network connections.

If necessary, commercial cables are available for trigger connections to a PNP photocell (see TRG Connector paragraph).

QLM700 has integrated on-board backup memory and therefore supports Backup and Restore procedures for the connected device and relative ID-NET™ network (if used). See the device's Backup and Restore procedure in the Help On Line.

For the 2KN-4K Family Scanners, Backup and Restore can also be performed using programming barcodes, see the Setup Procedure Using Programming Barcodes document on the reader's CD-ROM.

**NOTE**

For full compatibility with QLM700, the 2KN-4K Family Scanner must have software package 007_3 or later.

PACKAGE CONTENTS

Verify that the QLM700 and all the parts supplied with the equipment are present and intact when opening the packaging; the list of parts includes:

- QLM700 Gateway
- This Installation Manual
- Mounting screws and washers (2)
- M12 protection caps (5) pre-mounted

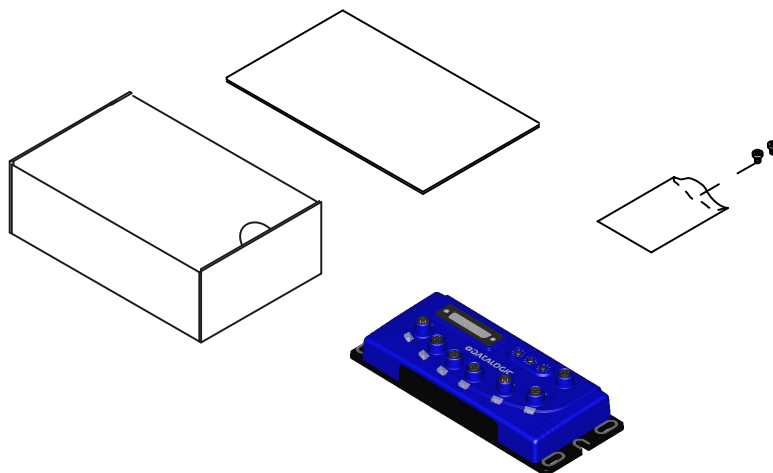

Figure 1 - Package Contents

ACCESSORIES

The following accessories are available on request for the QLM700:

Name	Description	Part Number
Field Mountable Connectors		
CBL-1487	PWR-IN CONNECTOR M12 5P F. A-Coded	93A050045
FMC600	QLM-I/O CONNECTOR M12 8P M. A-Coded	93ACC0040
Cables		
CS-A2-02-G-03	PWR-IN Cable M12/5P FEMALE 90°/4 WIRES 3M	95A251360
CS-A2-02-G-10	PWR-IN Cable M12/5P FEMALE 90°/4 WIRES 10M	95A251260
CAB-AUX03	SERIAL CABLE M12/3P MALE/DB9 3M	93A051385
CBL-1480-01	ID-NET Out/In M12/5P MALE/FEMALE 1M IDNET	93A050049
CBL-1480-02	ID-NET Out/In M12/5P MALE/FEMALE 2M IDNET	93A050050

SUPPORTED READING DEVICES

The QLM700 can be directly connected to all of the following readers through the 25-pin connector illustrated in Figure A.

Linear Scanners			2D Readers
DS2100N	DS2400N	DS4800	(future release)

MECHANICAL INSTALLATION

QLM700 can be mounted to various surfaces using the two M5x20 screw and washers included in the package:

- The M5x20 screws can be used to mount the QLM700 to metallic/plastic surfaces already prepared with M5 threaded holes.
- QLM700 can also be mounted to a Bosch Frame using the two M5x20 screws included in the package, plus two specific commercial T-nuts (for example the Bosch Rexroth *T-nut 10 M5*, cod. 3 842 530 283).
- Mounting to other surfaces, such as concrete walls or metallic panels, requires appropriate user-supplied parts (screws, screw anchors, nuts, etc).

The diagram below gives the overall dimensions of the QLM700 and shows the mounting through-holes.

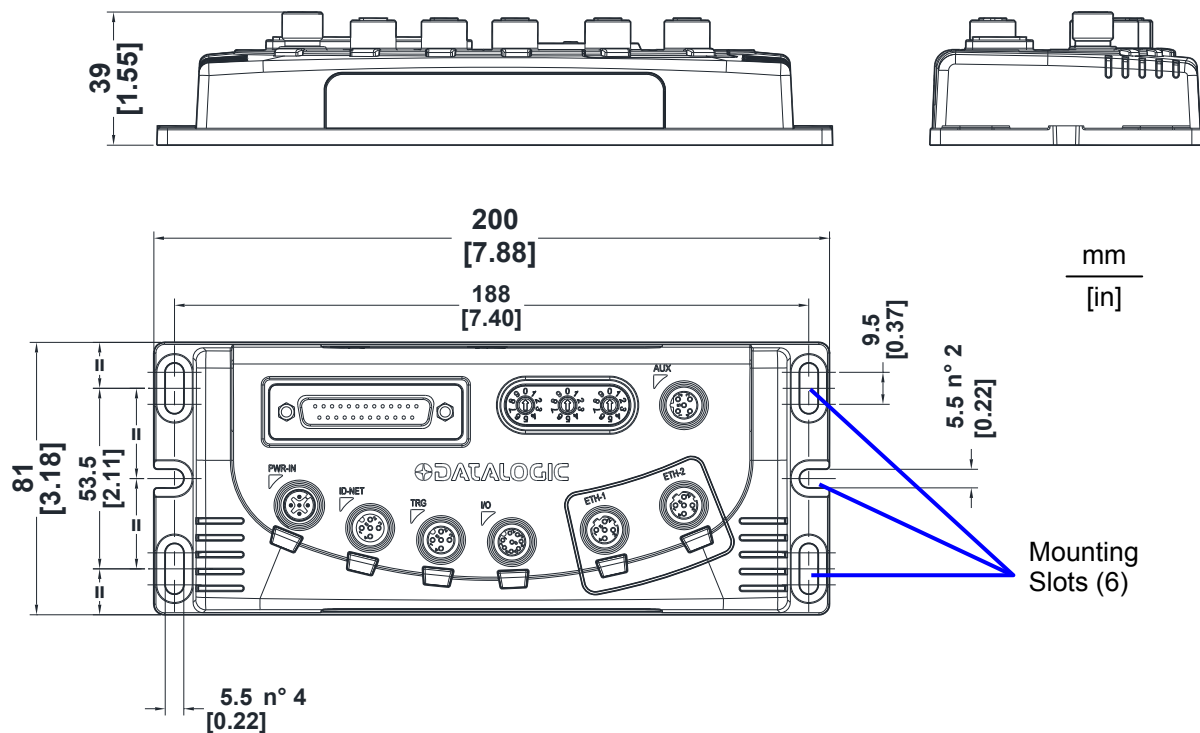
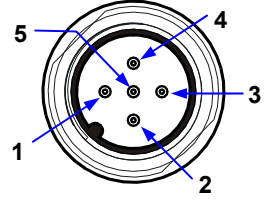
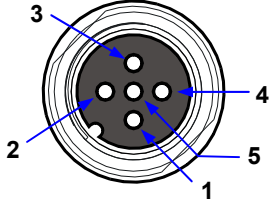
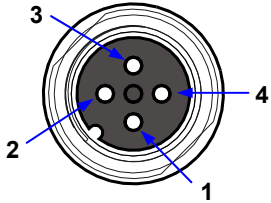
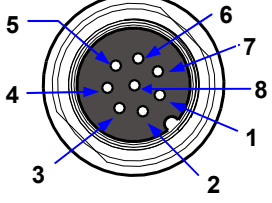
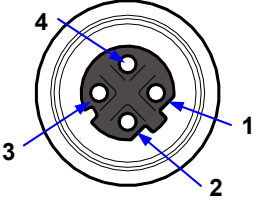
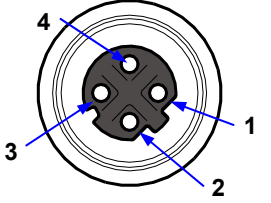
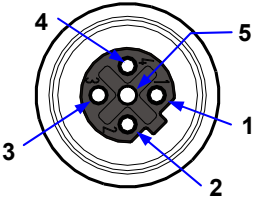

Figure 2 - Overall Dimensions

ELECTRICAL CONNECTIONS

CONNECTORS

<p>PWR-IN (Power In) M12 5P Male (A-coded)</p> <table border="1"> <thead> <tr> <th>Pin</th> <th>Function</th> </tr> </thead> <tbody> <tr><td>1</td><td>Vdc</td></tr> <tr><td>2</td><td>nc</td></tr> <tr><td>3</td><td>GND</td></tr> <tr><td>4</td><td>nc</td></tr> <tr><td>5</td><td>nc</td></tr> </tbody> </table>	Pin	Function	1	Vdc	2	nc	3	GND	4	nc	5	nc		<p>ID-NET (Out) M12 5P Female (A-coded)</p> <table border="1"> <thead> <tr> <th>Pin</th> <th>Function</th> </tr> </thead> <tbody> <tr><td>1</td><td>Shield</td></tr> <tr><td>2</td><td>Vdc</td></tr> <tr><td>3</td><td>GND</td></tr> <tr><td>4</td><td>ID+</td></tr> <tr><td>5</td><td>ID-</td></tr> </tbody> </table>	Pin	Function	1	Shield	2	Vdc	3	GND	4	ID+	5	ID-					
Pin	Function																														
1	Vdc																														
2	nc																														
3	GND																														
4	nc																														
5	nc																														
Pin	Function																														
1	Shield																														
2	Vdc																														
3	GND																														
4	ID+																														
5	ID-																														
<p>TRG (Trigger) M12 4P Female (A-coded)</p> <table border="1"> <thead> <tr> <th>Pin</th> <th>Function</th> </tr> </thead> <tbody> <tr><td>1</td><td>+V (I/O)</td></tr> <tr><td>2</td><td>nc</td></tr> <tr><td>3</td><td>-V (I/O)</td></tr> <tr><td>4</td><td>I1+ (trigger)</td></tr> </tbody> </table>	Pin	Function	1	+V (I/O)	2	nc	3	-V (I/O)	4	I1+ (trigger)		<p>I/O M12 8P Female (A-coded)</p> <table border="1"> <thead> <tr> <th>Pin</th> <th>Function</th> </tr> </thead> <tbody> <tr><td>1</td><td>+V (I/O)</td></tr> <tr><td>2</td><td>-V (I/O)</td></tr> <tr><td>3</td><td>I2+ (input)</td></tr> <tr><td>4</td><td>nc</td></tr> <tr><td>5</td><td>O1+ (output)</td></tr> <tr><td>6</td><td>O1- (output)</td></tr> <tr><td>7</td><td>O2+ (output)</td></tr> <tr><td>8</td><td>O2- (output)</td></tr> </tbody> </table>	Pin	Function	1	+V (I/O)	2	-V (I/O)	3	I2+ (input)	4	nc	5	O1+ (output)	6	O1- (output)	7	O2+ (output)	8	O2- (output)	
Pin	Function																														
1	+V (I/O)																														
2	nc																														
3	-V (I/O)																														
4	I1+ (trigger)																														
Pin	Function																														
1	+V (I/O)																														
2	-V (I/O)																														
3	I2+ (input)																														
4	nc																														
5	O1+ (output)																														
6	O1- (output)																														
7	O2+ (output)																														
8	O2- (output)																														

<p>ETH1 (Profinet IO Port 1) M12 4P Female (D-coded)</p> <table border="1"> <thead> <tr> <th>Pin</th> <th>Function</th> </tr> </thead> <tbody> <tr><td>1</td><td>TX+</td></tr> <tr><td>2</td><td>RX+</td></tr> <tr><td>3</td><td>TX-</td></tr> <tr><td>4</td><td>RX-</td></tr> </tbody> </table>	Pin	Function	1	TX+	2	RX+	3	TX-	4	RX-		<p>ETH2 (Profinet IO Port 2) M12 4P Female (D-coded)</p> <table border="1"> <thead> <tr> <th>Pin</th> <th>Function</th> </tr> </thead> <tbody> <tr><td>1</td><td>TX+</td></tr> <tr><td>2</td><td>RX+</td></tr> <tr><td>3</td><td>TX-</td></tr> <tr><td>4</td><td>RX-</td></tr> </tbody> </table>	Pin	Function	1	TX+	2	RX+	3	TX-	4	RX-	
Pin	Function																						
1	TX+																						
2	RX+																						
3	TX-																						
4	RX-																						
Pin	Function																						
1	TX+																						
2	RX+																						
3	TX-																						
4	RX-																						
<p>AUX M12 5P Female (B-coded)</p> <table border="1"> <thead> <tr> <th>Pin</th> <th>Function</th> </tr> </thead> <tbody> <tr><td>1</td><td>nc</td></tr> <tr><td>2</td><td>RXA</td></tr> <tr><td>3</td><td>GND</td></tr> <tr><td>4</td><td>TXA</td></tr> <tr><td>5</td><td>nc</td></tr> </tbody> </table>	Pin	Function	1	nc	2	RXA	3	GND	4	TXA	5	nc											
Pin	Function																						
1	nc																						
2	RXA																						
3	GND																						
4	TXA																						
5	nc																						

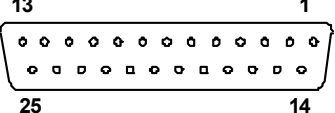
<p>Reader 25P D-Sub Female</p>															
<table border="1"> <thead> <tr> <th>Pin</th> <th>Function</th> </tr> </thead> <tbody> <tr><td>1, shell,</td><td>Reader Chassis</td></tr> </tbody> </table>	Pin	Function	1, shell,	Reader Chassis		<table border="1"> <thead> <tr> <th>Pin</th> <th>Function</th> </tr> </thead> <tbody> <tr><td>10</td><td>I2B</td></tr> </tbody> </table>	Pin	Function	10	I2B	<table border="1"> <thead> <tr> <th>Pin</th> <th>Function</th> </tr> </thead> <tbody> <tr><td>18</td><td>I1A</td></tr> </tbody> </table>	Pin	Function	18	I1A
Pin	Function														
1, shell,	Reader Chassis														
Pin	Function														
10	I2B														
Pin	Function														
18	I1A														
<table border="1"> <tbody> <tr><td>2</td><td>TXM</td></tr> </tbody> </table>	2	TXM	<table border="1"> <tbody> <tr><td>11</td><td>O2+</td></tr> </tbody> </table>	11	O2+	<table border="1"> <tbody> <tr><td>19</td><td>GND</td></tr> </tbody> </table>	19	GND	<table border="1"> <tbody> <tr><td>20</td><td>RXA</td></tr> </tbody> </table>	20	RXA				
2	TXM														
11	O2+														
19	GND														
20	RXA														
<table border="1"> <tbody> <tr><td>3</td><td>RXM</td></tr> </tbody> </table>	3	RXM	<table border="1"> <tbody> <tr><td>12</td><td>O2-</td></tr> </tbody> </table>	12	O2-	<table border="1"> <tbody> <tr><td>21</td><td>TXA</td></tr> </tbody> </table>	21	TXA	<table border="1"> <tbody> <tr><td>22</td><td>O1-</td></tr> </tbody> </table>	22	O1-				
3	RXM														
12	O2-														
21	TXA														
22	O1-														
<table border="1"> <tbody> <tr><td>4</td><td>RTSM</td></tr> </tbody> </table>	4	RTSM	<table border="1"> <tbody> <tr><td>13</td><td>Vdc</td></tr> </tbody> </table>	13	Vdc	<table border="1"> <tbody> <tr><td>23</td><td>ID+</td></tr> </tbody> </table>	23	ID+	<table border="1"> <tbody> <tr><td>24</td><td>ID-</td></tr> </tbody> </table>	24	ID-				
4	RTSM														
13	Vdc														
23	ID+														
24	ID-														
<table border="1"> <tbody> <tr><td>5</td><td>CTSM</td></tr> </tbody> </table>	5	CTSM	<table border="1"> <tbody> <tr><td>14</td><td>nc</td></tr> </tbody> </table>	14	nc	<table border="1"> <tbody> <tr><td>25</td><td>GND</td></tr> </tbody> </table>	25	GND							
5	CTSM														
14	nc														
25	GND														
<table border="1"> <tbody> <tr><td>6</td><td>I2A</td></tr> </tbody> </table>	6	I2A	<table border="1"> <tbody> <tr><td>15</td><td>nc</td></tr> </tbody> </table>	15	nc										
6	I2A														
15	nc														
<table border="1"> <tbody> <tr><td>7</td><td>GND</td></tr> </tbody> </table>	7	GND	<table border="1"> <tbody> <tr><td>16</td><td>nc</td></tr> </tbody> </table>	16	nc										
7	GND														
16	nc														
<table border="1"> <tbody> <tr><td>8</td><td>O1+</td></tr> </tbody> </table>	8	O1+	<table border="1"> <tbody> <tr><td>17</td><td>nc</td></tr> </tbody> </table>	17	nc										
8	O1+														
17	nc														
<table border="1"> <tbody> <tr><td>9</td><td>nc</td></tr> </tbody> </table>	9	nc													
9	nc														

PWR-IN

PWR-IN is a 5-pin Male A-Coded M12 connector. Input power must **only** be supplied to the QLM700 at the PWR-IN connector; from there it is internally distributed to the connected reading device, the ID-NET™ network and all the I/O devices.

You can use the CBL-1487 connector and follow the pinout above to build your own Power Supply connector cable.

You can also use one of the CS-A2-02-G-xx cables which terminate in four single stranded wires. **The brown wire corresponds to pin 1 Vdc, the blue wire to pin 3 GND.** The white and black wires are not used.

The LED placed below the PWR-IN connector, signals the presence of input Power. If the polarity is correct, the LED is blue; if the polarity is reversed, the LED is red; if no power is supplied, the LED is off.

 CAUTION	<p><i>The QLM700 and the connected reader are protected from polarity inversion through the PWR-IN connector, but this is not true for the other devices connected to the ID-NET™ Network, TRG and I/O connectors (i.e. external trigger, encoder, etc.). Check the correct Power Supply polarity looking at the PWR-IN LED before connecting other devices to the QLM700.</i></p>
---	---

The power supply must be between 10 and 30 Vdc only.

Voltage Drop and Max Distributed Current Calculations

For correct ID-NET™ network management, the maximum number of readers which can propagate power through the QLs must be calculated so that max distributed current is not exceeded (4.0 A), and so voltage drop doesn't affect reader functioning. This is done according to the following formula:

$$\text{Voltage Drop} = \frac{(\text{Max Reader Current} \times \text{Number of readers}) \times (\text{Resistance per Meter per wire}^* \times \text{Cable length in Meters})}{2}$$

* the resistance calculation must include both wires (Vdc and GND).

Example:

An ID-NET™ network is composed of 4 DS2100N readers. Three 2-meter ID-NET™ cables are used to connect the readers, which have Cable Resistance = 0.058 Ohms per meter per wire. The network power is 24 Vdc.

$$(0.125 \text{ A} \times 4 \text{ readers}) \times [(0.058 \times 2) \times 6 \text{ meters}] = 0.348 \text{ Vdc voltage drop}$$

$$24 \text{ Vdc} - 0.348 = 23.65 \text{ Vdc at reader number 4 (worst case)}$$

Integrate a sufficient number of QL200s to resupply network power.

ID-NET

ID-NET is a 5-pin Female A-Coded M12 connector. It is used to connect the network signals and the power supply for the **ID-NET™ Network** towards ID-NET™ Slaves.

Pins 2 and 3 on the ID-NET connector carry the same power supply lines present on pins 1 and 3 of the PWR-IN connector; however power must only be supplied to the QLM700 through the PWR-IN connector.

In an ID-NET™ network, the reading device connected to the QLM700 **must** be configured as an ID-NET™ Master; to facilitate the network setup, the QLM700 already provides an internal bus termination resistor (the Master is the first device of the chain).

 CAUTION	<p><i>When using QLM700 in an ID-NET™ network application, the network termination cap must be connected to the last device of the chain.</i></p>
---	---

TRG CONNECTOR

TRG is a 4-pin Female A-Coded M12 connector. You can connect a **PNP** photocell to it, which will act as an External Trigger (Input 1) for the connected reading device. Several commercial cables are available to make this connection such as the SAC-4P-M12MS series by Phoenix Contact.

When the Trigger is activated, the LED below the TRG connector is yellow.

See the Technical Features table for electrical specifications.

 NOTE	<p><i>Pins 1 +V (I/O) and 3 -V (I/O) are derived from Vdc and GND and are useful for supplying the external trigger through the QLM700 power source, however pins 1 and 3 of the TRG connector must not be used as power supply inputs to the QLM700.</i></p>
--	--

I/O CONNECTOR

I/O is an 8-pin Female A-Coded M12 connector. It carries the signals for the additional I/O (Input 2 / Secondary Trigger, Output 1 and Output 2) as shown below. If Input 2 is used as a Secondary Trigger, the photocell must be a **PNP** device.

Note that all these signals are relative to the connected reader.

When the Input 2 (Secondary Trigger) is activated, the LED below the I/O connector is yellow.

When the Output 1 signal is activated, the LED below the I/O connector is red.

When the Output 2 signal is activated, the LED below the I/O connector is green.

See the Technical Features table for electrical specifications.

 NOTE	<p><i>Pins 1 +V (I/O) and 2 -V (I/O) are derived from Vdc and GND and are useful for supplying the I/O devices through the QLM700 power source, however pins 1 and 2 of the I/O connector must not be used as power supply inputs to the QLM700.</i></p>
--	---

 NOTE	<p><i>To reduce electromagnetic interference use a shielded cable for I/O connections.</i></p>
--	--

ETH1 CONNECTOR

ETH1 is a 4-pin Female D-Coded M12 connector. It is used to connect the QLM700 to a Profinet IO network in either Daisy-Chain bus, or Star topologies.

ETH2 CONNECTOR

ETH2 is a 4-pin Female D-Coded M12 connector. It is used to connect the QLM700 to a Profinet IO network in either Daisy-Chain bus, or Star topologies.

AUX CONNECTOR

AUX is a 5-pin Female B-Coded M12 connector. It is used to connect the reading device connected to the QLM700 to a configuration program on a PC. For example for the DS2100N/2400N/4800 barcode readers you should use the Genius™ configuration tool. You can use the CAB-AUX 03 accessory cable to easily connect the QLM700 to a PC DB9 serial port.

SYSTEM WIRING/CABLING

The connection and wiring procedure for QLM700 is described as follows:

- 1) Be sure that all the QLM700 M12 connectors are free (not connected).
- 2) Build your power supply cable using the CBL-1487 accessory connector following the pinout shown in the Connectors paragraph (PWR-IN Connector). Use an adequate cable/wire diameter, according to the total current required for the application (QLM700, connected reader, trigger, other I/O devices, ID-NET™ Network components). One of the CS-A2-02-G-xx accessory cables can also be used (see PWR-IN paragraph).
- 3) Connect the power supply cable to the QLM700 (with no other devices connected) and apply power checking that the polarity is correct: the **blue** LEDs below both PWR-IN and ID-NET (out) M12 connectors must be turned on. If instead the red LEDs are turned on, the polarity is incorrect; switch off the power and check the cable. Correct the situation so that the power supply polarity is correct.
- 4) When the connection to the power supply is correct switch off the power.
- 5) Connect the reading device to the 25-pin connector.
- 6) If your application requires it, connect a **PNP** photocell to the TRG connector. Several commercial cables are available (see TRG Connector paragraph).
- 7) If your application involves other I/O devices you can build your I/O cable using the FMC600 accessory and following the pinout shown in the Connectors paragraph (I/O Connector); next connect your cable to the I/O connector.
- 8) If an ID-NET™ network is required in your application, build the network using the proper Datalogic Automation accessory cables, connectors and termination cap. See the Typical Layouts for example.
- 9) Connect the QLM700 to the Profinet IO Network using proper Ethernet cables. If the ETH2 connector is not used to propagate the network, use the M12 protection cap.

- 10) Preset the Node Address of the QLM700, as shown in the Profinet IO Network Address Selectors paragraph.
- 11) Switch on the power supply; after a while (the system needs some seconds to boot), and if the Profinet IO Host is ready and has correctly recognized the QLM700, the green Network Status and Module Status LEDs below both ETH1 and ETH2 M12 connectors should be turned on.
- 12) If you need to configure the reading device, connect the AUX port through the CAB-AUX03 accessory cable to a PC and run the configuration program (i.e. Genius™).

Now the system is ready to operate.

**NOTE**

To avoid electromagnetic interference connect the QLM700 housing to a good earth ground.

PROFINET IO NETWORK ADDRESS SELECTORS

An IPv4 IP Address is composed of four octets (bytes) and can be represented by four decimal numbers separated by dots (dotted notation). For example, in the following address: 195.24.65.215, the last octet is 215.

The QLM700 has three embedded rotary switches allowing easy manual selection of the last octet of the **IP Address**. Valid selections for the last octet of the IP Address are shown in the table below. Address selections outside of these values are not accepted.

000-255 = A valid selection for the last octet of the IP Address

777 = Remote Assignment through the IPConfig application available on the reader's CD-ROM.

888 = Static Assignment – set manually through Genius™

999 = set through a DHCP server

Using a small screwdriver, set the three rotary switches manually to the desired IP Address (reading from left to right). Figure 3 shows address **107** as the last octet.

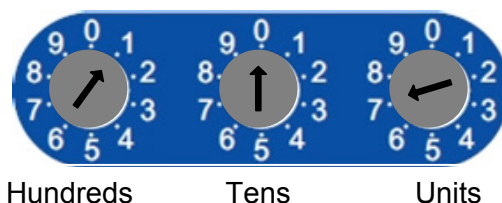

Figure 3 – Profinet IO Network Address Selectors

So, for the example above, the IP Address stored in the connected reading device is 195.24.65.215 and the configuration defined by the three rotary switches is 107; when the gateway is switched on the IP Address is assumed to be 195.24.65.**107**.

The full IP Address as well as the Gateway Address can be set by printing and then reading custom barcode labels as described in the "Custom Barcode IP Address/Station Name Assignment" document available on the reader's CD-ROM.

INDICATOR LEDS

There are six Indicator LEDs which signal power, I/O and Profinet IO communication activity and are visible below the M12 connectors (excluding AUX).

PWR-IN / ID-NET

The Power LEDs are **blue** when power is correctly applied to the QLM700.

These LEDs are red if power polarity is incorrect. In this case the QLM700 and the connected reading device are protected.

	<p><i>If external I/O devices are powered through QLM700 (connected to +V I/O and -V I/O), they are not protected from polarity inversion.</i></p>
CAUTION	

TRG

The Trigger LED is yellow and it is on when the Trigger (presence sensor) photocell is activated.

I/O

The I/O LEDs reflect the activity of the supplemental I/O devices connected to the reading device through the QLM700.

The Input 2 LED is yellow and it is on when the supplemental photocell is activated.

The Output 1 LED is red and it is on when the reading device Output 1 is activated.

The Output 2 LED is green and it is on when the reading device Output 2 is activated.

ETH1

There are two LEDs below ETH1 which act as the 'Profinet IO Network Status' indicator and the 'Port 1 Link Activity' indicator. They are driven according to the following tables.

Network Status LED	
Off	No power, No connection with IO controller
Green	connection with IO controller established, IO controller in Run state
Flashing Green	connection with IO controller established, IO controller in Stop state

Port 1 Link Activity LED	
Blinking Green	Link Activity on Port 1 @ 100 Mbit/s
Blinking Yellow	Link Activity on Port 1 @ 10 Mbit/s

ETH2

There are two LEDs below ETH2 which act as the 'Profinet IO Module Status' indicator and the 'Port 2 Link Activity' indicator.

They are driven according to the following table.

Module Status LED	
Off	No power or Not initialized
Green	Normal operation
Flashing Green (1 flash)	Diagnostic event(s)
Flashing Green (2 flashes)	Blink (node identification)
Red	Exception error
Flashing Red (1 flash)	Configuration error
Flashing Red (2 flashes)	IP address not set
Flashing Red (3 flashes)	Station Name not set
Flashing Red (4 flashes)	Internal error

Port 2 Link Activity LED	
Blinking Green	Link Activity on Port 2 @ 100 Mbit/s
Blinking Yellow	Link Activity on Port 2 @ 10 Mbit/s

TYPICAL LAYOUTS

The following figure shows the general system layout.

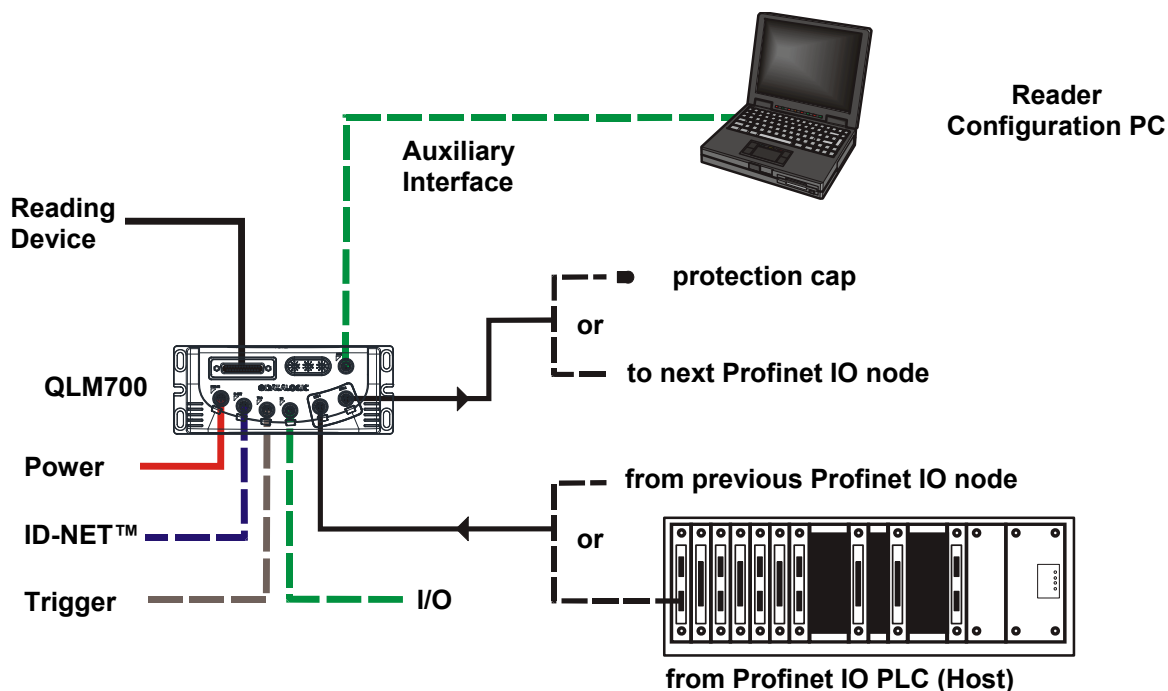

Figure 4 – General System Layout

The dotted lines in the figure refer to optional hardware configurations.

The general system layout allows the QLM700 Profinet IO Gateway to connect one of the compatible serial reading devices (2KN, 4K Scanner), collect its information and send it to a Profinet IO Host.

In a daisy chain topology, the Profinet IO network from the Host is connected to one of the two QLM700 Profinet IO ports. The other Profinet IO port connects either to the next Profinet IO node or is left unconnected (sealed by the protection cap).

In a star topology, one of the two Profinet IO ports is connected to an Ethernet switch; the other port remains unconnected.

The reading device connects to the 25-pin connector.

The ID-NET™ interface allows a network of ID-NET™ Slaves to be connected to the QLM700's reading device which acts as the ID-NET™ Master.

The reading device auxiliary interface signals are available on the AUX connector which can be quickly connected to a portable PC for reader configuration.

The following diagrams are examples showing layout connections and are not intended to represent power limits, which instead, depend on each specific application. See "Voltage Drop and Max Distributed Current Calculations".

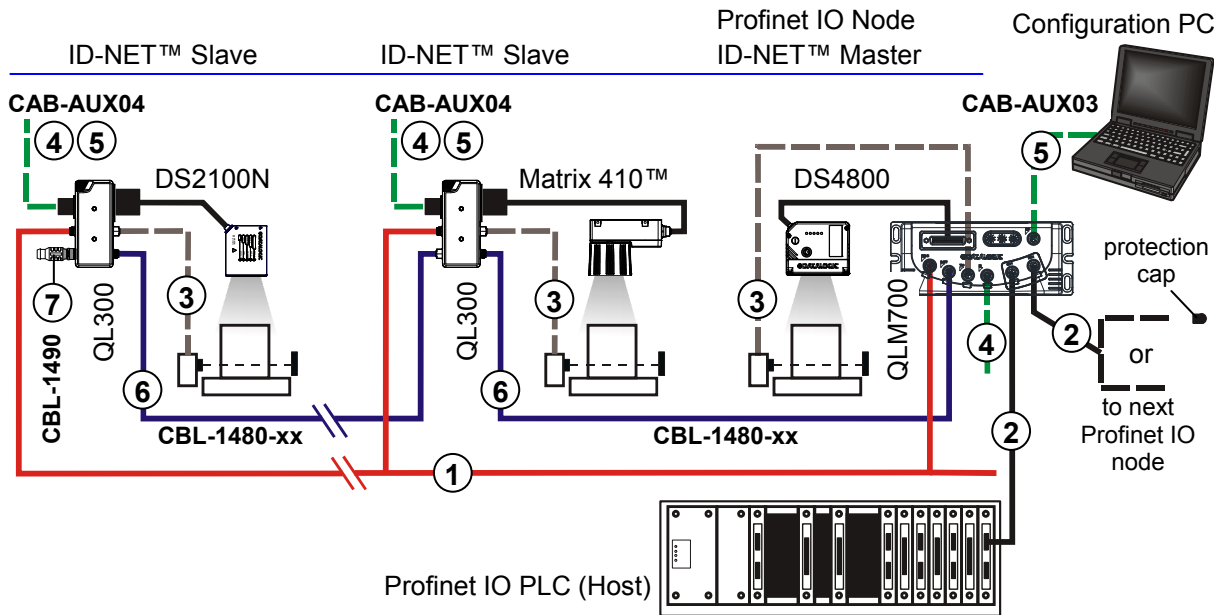

ID-NET™ Multidata Network - DS4800 Master with QLM700 + mixed Slaves with QL300s

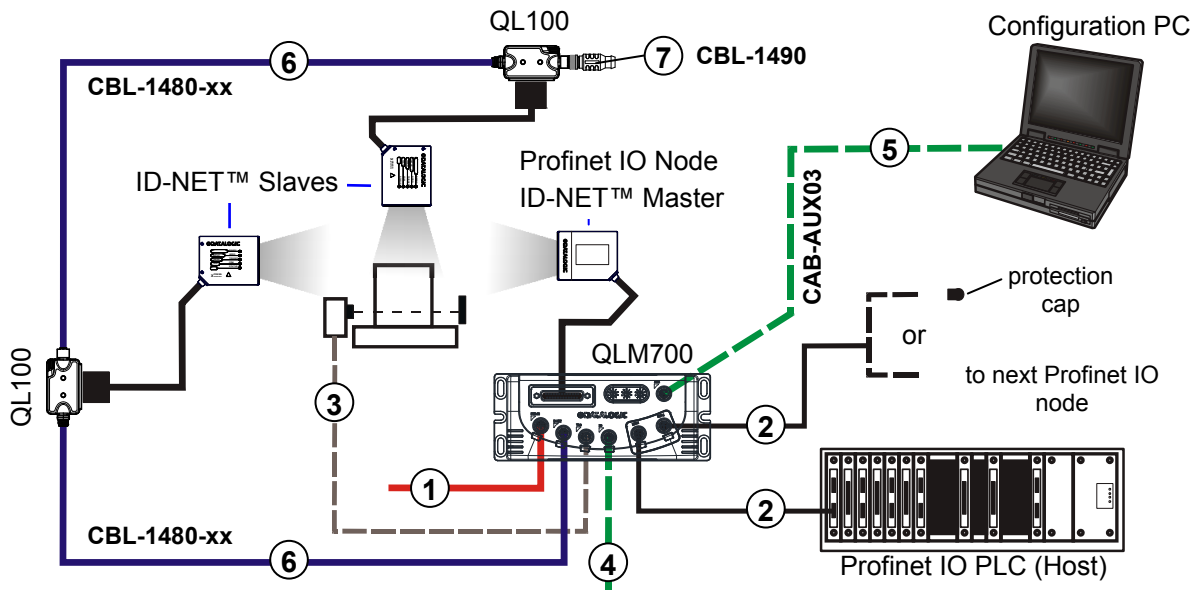

ID-NET™ Synchronized Network - DS2100N Master with QLM700 + DS2100N Slaves with QL100s

- ① Input Power
- ② Profinet IO Interface
- ③ External Trigger (for On-Line Mode)
- ④ External Digital I/O Devices
- ⑤ Aux port for Reader Configuration
- ⑥ ID-NET™ Network
- ⑦ ID-NET™ Terminator

NOTE The ID-NET™ network must be terminated inserting an ID-NET™ terminator into the last QL in the network. ID-NET™ on the QLM700 is internally terminated.

TECHNICAL FEATURES

ELECTRICAL FEATURES	
Supply Voltage	10 to 30 Vdc
Consumption	0.3 - 0.2 A
Maximum Distributed Current Allowed • ID-NET™	4.0 A max
Limited Current Consumption • QLM700 + reading device • Trigger + I/O device (see related device manuals)	1.85 A max 0.75 A max
Inputs: Input1 (TRG), Input 2 Voltage Current Consumption	Optocoupled 30 Vdc max. 12 mA max.
Outputs: Output 1, Output 2 V _{CE} Collector Current V _{CE} Saturation Power Dissipation	Optocoupled 30 Vdc max. 40 mA continuous max.; 130 mA pulsed max. 1V max. @ 10 mA 80 mW max. @ 45 °C (ambient temperature)
COMMUNICATION INTERFACES	
Host Interface Auxiliary ID-NET™	Profinet IO 10/100 Mbit/s RS232 up to 115.2 kbit/s RS485 Half Duplex up to 1 Mbit/s
Communication Protocols	Datalogic Application Driver (DAD Driver)
USER INTERFACE	
LED Indicators: Power/ID-NET Trig I/O ETH1 ETH2	Power On/Polarity Error (blue/red) Trigger Activity (yellow) IN2 (yellow), OUT1 (red), OUT2 (green), Network Status (green/red), Link Activity (green/yellow), Module Status (green/red), Link Activity (green/yellow)
PHYSICAL FEATURES	
Mechanical Dimensions	200 x 81 x 40 mm (7.9 x 3.2 x 1.6 in.)
Weight	500 g. (17.64 oz.)
ENVIRONMENTAL FEATURES	
Operating Temperature	0° to 50 °C (+32° to 122 °F)
Storage Temperature	-20° to 70 °C (-4° to 158 °F)
Humidity max.	90% non condensing
Vibration Resistance EN 60068-2-6	14 mm @ 2 to 10 Hz; 1.5 mm @ 13 to 55 Hz; 2 g @ 70 to 200 Hz; 2 hours on each axis
Bump Resistance EN 60068-2-29	30 g; 6 ms; 5000 shocks on each axis
Protection Class EN 60529	IP65 *

The features given are typical at a 25 °C ambient temperature (if not otherwise indicated).

* when all the M12 connectors and reading device are correctly connected (or closed with a proper protection cap).

COMPLIANCE

POWER SUPPLY

This product is intended to be installed by Qualified Personnel only.

This device is intended to be supplied by a UL Listed or CSA Certified Power Unit with Class 2 or LPS power source.

 CAUTION	<i>Total power consumption is given by adding the QLM700 power consumption to that of all the devices powered through the QLM700 (reading device, P.S., I/O). Refer to the manual of the connected devices for details about minimum/maximum supply voltage and power consumption.</i>
---	--

CE COMPLIANCE

Warning: This is a Class A product. In a domestic environment this product may cause radio interference in which case the user may be required to take adequate measures.

FCC COMPLIANCE

Modifications or changes to this equipment without the expressed written approval of Datalogic could void the authority to use the equipment.

This device complies with PART 15 of the FCC Rules. Operation is subject to the following two conditions: (1) This device may not cause harmful interference, and (2) this device must accept any interference received, including interference which may cause undesired operation.

This equipment has been tested and found to comply with the limits for a Class A digital device, pursuant to part 15 of the FCC Rules. These limits are designed to provide reasonable protection against harmful interference when the equipment is operated in a commercial environment. This equipment generates, uses, and can radiate radio frequency energy and, if not installed and used in accordance with the instruction manual, may cause harmful interference to radio communications. Operation of this equipment in a residential area is likely to cause harmful interference in which case the user will be required to correct the interference at his own expense.

**Datalogic Automation S.r.l.**

Via Lavino 265

40050 Monte San Pietro

Bologna - Italy

www.automation.datalogic.com*declares that the***QLxxx and QLMxxx; Connection module***and all its models**are in conformity with the requirements of the European Council Directives listed below:***2004 / 108 / EC EMC Directive***This Declaration is based upon compliance of the products to the following standards:***EN 55022 (CLASS A ITE), DECEMBER 2010:***INFORMATION TECHNOLOGY EQUIPMENT
RADIO DISTURBANCE CHARACTERISTICS
LIMITS AND METHODS OF MEASUREMENTS***EN 61000-6-2, SEPTEMBER 2005:***ELECTROMAGNETIC COMPATIBILITY (EMC)
PART 6-2: GENERIC STANDARDS - IMMUNITY FOR INDUSTRIAL
ENVIRONMENTS*

Monte San Pietro, January 20th , 2012

Paolo Morselli
Quality Manager