



---

## **SG2 EXTENDED**



**Instruction Manual**

---



ORIGINAL INSTRUCTIONS (ref. 2006/42/EC)

Datalogic Automation S.r.l.  
Via Lavino, 265  
40050 - Monte S. Pietro  
Bologna - Italy

SG2 EXTENDED Instruction Manual  
Ed.: 10/2012

© 2012 Datalogic Automation S.r.l. □ ALL RIGHTS RESERVED. □ Protected to the fullest extent under U.S. and international laws. Copying, or altering of this document is prohibited without express written consent from Datalogic Automation S.r.l.

Datalogic and the Datalogic logo are registered trademarks of Datalogic S.p.A. in many countries, including the U.S.A. and the E.U.

All brand and product names mentioned herein are for identification purposes only and may be trademarks or registered trademarks of their respective owners.

Datalogic shall not be liable for technical or editorial errors or omissions contained herein, nor for incidental or consequential damages resulting from the use of this material.

10/10/2012

**Datalogic Automation S.r.l.**

Via Lavino 265  
40050 Monte San Pietro  
Bologna - Italy  
[www.automation.datalogic.com](http://www.automation.datalogic.com)

*declares that the*

**SG2 ; SAFETY LIGHT CURTAINS - ELECTRO-SENSITIVE PROTECTIVE EQUIPMENT  
(TYPE 2 ESPE)**

*and all its models*

*are in conformity with the requirements of the European Council Directives listed below:*

**2006 / 42 / EC Machinery Directive  
2004 / 108 / EC EMC Directive  
2006 / 95 / EC Low Voltage Directive**

*This Declaration is based upon compliance of the products to the following standards:*

<b>EN 61496-1: 2004</b>	<b>SAFETY OF MACHINERY - ELECTRO-SENSITIVE PROTECTIVE EQUIPMENT. PART 1: GENERAL REQUIREMENTS AND TESTS</b>
<b>IEC 61496-2: 2006</b>	<b>SAFETY OF MACHINERY - ELECTRO-SENSITIVE PROTECTIVE EQUIPMENT. PART 2: PARTICULAR REQUIREMENTS FOR EQUIPMENT USING ACTIVE OPTO-ELECTRONIC PROTECTIVE DEVICES (AOPDs)</b>
<b>IEC 61508-1/3/4: 1998 IEC 61508-2:2000</b>	<b>FUNCTIONAL SAFETY OF ELECTRICAL/ELECTRONIC/PROGRAMMABLE ELECTRONIC SAFETY-RELATED SYSTEMS.</b>
<b>EN 954-1: 1996</b>	<b>SAFETY OF MACHINERY -- SAFETY-RELATED PARTS OF CONTROL SYSTEMS</b>
<b>EN ISO 13849-1: 2008</b>	<b>SAFETY OF MACHINERY -- SAFETY-RELATED PARTS OF CONTROL SYSTEMS -- PART 1: GENERAL PRINCIPLES FOR DESIGN</b>
<b>EN 62061: 2005</b>	<b>SAFETY OF MACHINERY -- FUNCTIONAL SAFETY OF SAFETY-RELATED ELECTRICAL, ELECTRONIC AND PROGRAMMABLE ELECTRONIC CONTROL SYSTEMS</b>
<b>EN 50178:1997</b>	<b>ELECTRONIC EQUIPMENT FOR USE IN POWER INSTALLATIONS</b>
<b>EN 61000-6-2: 2005</b>	<b>ELECTROMAGNETIC COMPATIBILITY (EMC) PART 6-2: GENERIC STANDARDS - IMMUNITY FOR INDUSTRIAL ENVIRONMENTS</b>
<b>EN 55022 (Class A ITE): 2010</b>	<b>LIMITS AND METHODS OF MEASUREMENTS OF RADIO DISTURBANCE OF INFORMATION TECHNOLOGY EQUIPMENT</b>

*Conformity has been certified by the following Notified/Competent Body (identification n°0123): TÜV SÜD Rail GmbH, Ridlerstrasse, 65 – D80339 München*

*Datalogic Automation have a quality system certified by the CSQ, Nr. 9115.IES2, as per ISO 9001 and have therefore observed the regulations foreseen during development and production*

Monte San Pietro, January 20th 2012

Paolo Morselli  
Quality Manager

*Morselli Paolo*



# INDEX

---

<b>1. GENERAL INFORMATION</b>	<b>1</b>
1.1. General description of the safety light curtains	1
1.1.1. Package contents	2
1.2. New features compared to the SF2 Series	2
1.3. How to choose the device	3
1.3.1. Resolution	3
1.3.2. Controlled height	4
1.3.3. Minimum installation distance	5
1.4. Typical applications	8
1.5. Safety information	10
<b>2. INSTALLATION MODE</b>	<b>11</b>
2.1. Precautions to be observed for the choice and installation of the device	11
2.2. General information on device positioning	12
2.2.1. Minimum installation distance	13
2.2.2. Minimum distance from reflecting surfaces	14
2.2.3. Emitter and receiver orientation	16
2.2.4. Installation of several adjacent safety light curtains	17
2.2.5. Use of deviating mirrors	19
2.2.6. Controls after first installation	20
<b>3. MECHANICAL MOUNTING</b>	<b>21</b>
<b>4. ELECTRICAL CONNECTIONS</b>	<b>24</b>
4.1. Notes on connections	25
4.2. Earth connection	28
<b>5. ALIGNMENT PROCEDURE</b>	<b>29</b>
5.1. Correct alignment procedure	30
<b>6. FUNCTIONING MODE</b>	<b>32</b>
6.1. Reset mode	32
6.2. Test function	33
6.3. Reset function	33
6.4. EDM function	34
6.5. Anti-interference function for range reduction	35
6.6. Alignment aid function	36
<b>7. DIAGNOSTIC FUNCTIONS</b>	<b>37</b>
7.1. User interface	37
7.2. Diagnostic messages	38
<b>8. PERIODICAL CHECKS</b>	<b>41</b>
8.1. General information and useful data	42
8.2. Warranty	42
<b>9. DEVICE MAINTENANCE</b>	<b>43</b>
9.1. Product disposal	43
<b>10. TECHNICAL DATA</b>	<b>44</b>
<b>11. LIST OF AVAILABLE MODELS</b>	<b>45</b>
<b>12. OVERALL DIMENSIONS</b>	<b>47</b>
<b>13. OUTFIT</b>	<b>48</b>
<b>14. ACCESSORIES</b>	<b>49</b>
14.1. Angled fixing bracket	49
14.2. Angled fixing bracket mounting	50
14.3. Deviating mirrors	51
14.4. Columns and floor stands	52
14.5. Protective stands	53
14.6. Test piece	53
14.7. Connection cables	54
14.8. Safety relay	55
<b>15. GLOSSARY</b>	<b>56</b>

## 1. GENERAL INFORMATION

### 1.1. General description of the safety light curtains

The safety light curtains of the SG2 series are optoelectronic multibeam devices that are used to protect working areas that, in presence of machines, robots, and automatic systems in general, can become dangerous for operators that can get in touch, even accidentally, with moving parts.

The light curtains of the SG2 series are Type 4 intrinsic safety systems used as accident-prevention protection devices and are manufactured in accordance with the international Standards in force for safety, in particular:

**CEI IEC 61496-1:** 2004 Safety of machinery: electrosensitive protective equipment. Part 1: General prescriptions and tests.

**CEI IEC 61496-2:** 2006 Safety of machinery: electrosensitive protective equipment - Particular requirements for equipment using active optoelectronic protective devices.

The device, consisting of one emitter and one receiver housed inside strong aluminium profiles, generates infrared beams that detect any opaque object positioned within the light curtain detection field.

The emitter and the receiver are equipped with the command and control functions. The connections are made through a M12 connector located in the lower side of the profile.

The synchronisation between the emitter and the receiver takes place optically, *i.e.* no electrical connection between the two units is required.

The microprocessor guarantees the check and the management of the beams that are sent and received through the units: The microprocessor LEDs inform the operator about the general conditions of the safety light curtain (see section 7 “*Diagnostic functions*”).

The device consists in 2 units that, according to the model, are composed by one or several emitting and receiving modules.

The receiver checks the control operations and safety actions.

During installation, two yellow LEDs facilitate the alignment of both units (see chapter 5 “*Alignment procedure*”).

As soon as an object, a limb or the operator’s body accidentally interrupts one or some of the infrared beams sent by the emitter, the receiver immediately opens the OSSD outputs and blocks the MPCE machine (if correctly connected to the OSSD).

Some parts or sections of this manual containing important information for the operator are preceded by a note:



Notes and detailed descriptions about particular characteristics of the safety devices in order to better explain their functioning.

Special instructions regarding the installation process.



The information provided in the paragraphs following this symbol is very important for safety and may prevent accidents.

Always read this information accurately and carefully follow the advice to the letter.

This manual contains all the information necessary for the selection and operation of the safety devices.

However, specialised knowledge not included in this technical description is required for the planning and implementation of a safety light curtain on a power-driven machine. As the required knowledge may not be completely included in this manual, we suggest the customer to contact DATALOGIC AUTOMATION Technical Service for any necessary information relative to the functioning of the SG2 light curtains and the safety rules that regulate the correct installation (see chapter 8 “*Periodical checks*”).

### 1.1.1. *Package contents*

Package contains the following objects:

- Receiver (RX)
- Emitter (TX)
- SG2-E quick installation guide
- SG2-E CD containing this manual and other documents
- Checklist and periodical maintenance schedule
- 4 rotating brackets and specific fasteners
- 2 angled fixing brackets for models with heights included between 1200 and 1800 mm

### 1.2. **New features compared to the SF2 Series**

The SG2-E safety light curtains, compared to the SF2 series, present the following new features:

- Increased operating distance
- Range enlargement with 150 to 1800 mm controlled heights
- Reduced response times
- New fastening system with rotating brackets
- New mechanical profile compatible with SE accessories
- Different positioning of synchronisation optics (the first one from the reference line)

Compared to SG2-B, SG2-E has the following features:

- EDM function
- Anti-interference function through range selection on the Tx unit
- Selectable manual/automatic restart function
- Advance signalling for alignment and normal functioning

**1.3. How to choose the device**

There are at least three different main characteristics that should be considered when choosing a safety light curtain, after having evaluated the risk assessment:

**1.3.1. Resolution**

The resolution of the device is the minimum dimension that an opaque object must have in order to obscure at least one of the beams that constitute the sensitive area.

The resolution strictly depends on the part of the body to be protected.

R = 30 mm      hand protection



R = 50 mm  
R = 90 mm      presence control



As shown in Fig.1, the resolution depends only on the geometrical characteristics of the lenses, diameter and distance between centres, and is independent from any environmental and operating conditions of the safety light curtain.

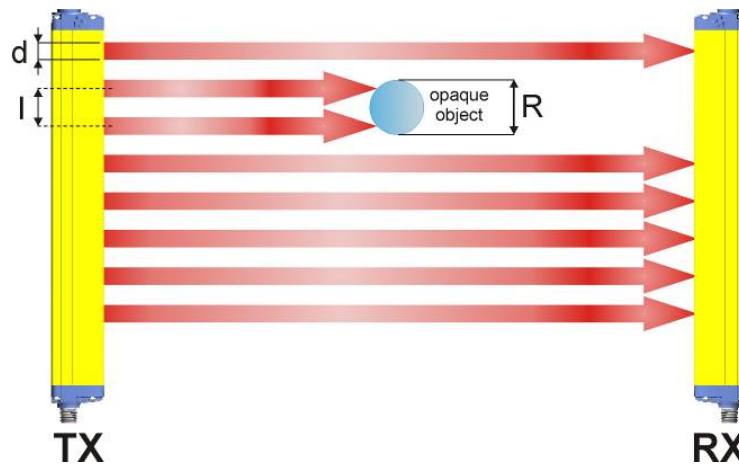

**Fig. 1**

The resolution value is obtained applying the following formula:

$$R = l + d$$

where:

*l* = Distance between two adjacent optics

*d* = Lens diameter

**1.3.2. Controlled height**

The controlled height is the height protected by the safety light curtain (**H<sub>p</sub>**)

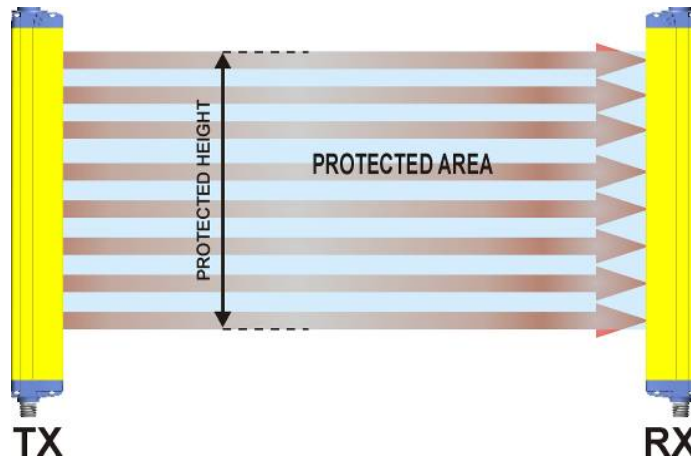

**Fig. 2**

The SG2-E controlled height is delimited by the yellow line pad-printed on the front glass and by the dimensions listed in the table:

Model	Controlled height H <sub>p</sub> (mm)
SG2-30-015-OO-E-C	150
SG2-xx-030-OO-E-C	300
SG2-xx-045-OO-E-C	450
SG2-xx-060-OO-E-C	600
SG2-xx-075-OO-E-C	750
SG2-xx-090-OO-E-C	900
SG2-xx-105-OO-E-C	1050
SG2-xx-120-OO-E-C	1200
SG2-xx-135-OO-E-C	1350
SG2-xx-150-OO-E-C	1500
SG2-xx-165-OO-E-C	1650
SG2-xx-180-OO-E-C	1800

xx = Resolution (30mm – 50mm – 90mm)



### 1.3.3. Minimum installation distance

The safety device must be positioned at a specific safety distance (Fig. 3). This distance must ensure that the dangerous area cannot be reached before the dangerous motion of the machine has been stopped by the ESPE.

The safety distance depends on 4 factors, according to the EN-999 Standard:

- Response time of the ESPE (the time between the effective beam interruption and the opening of the OSSD contacts).
- Machine stopping time (the time between the effective opening of the contacts of the ESPE and the real stop of the dangerous motion of the machine).
- ESPE resolution.
- Approaching speed of the object to be detected.

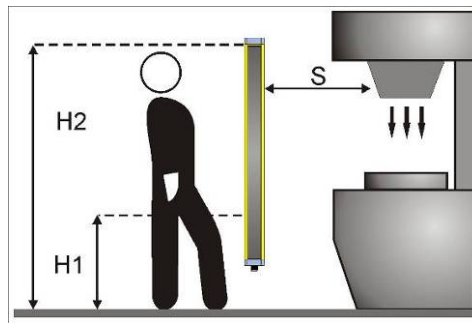

Fig. 3

The following formula is used for the calculation of the safety distance:

$$S = K (t_1 + t_2) + C$$

where:

S = Minimum safety distance in mm.

K = Speed of the object, limb or body approaching the dangerous area in mm/sec.

t<sub>1</sub> = Response time of the ESPE in seconds  
(see chapter 10 "Technical data")

t<sub>2</sub> = Machine stopping time in seconds

d = Resolution of the system

C = Additional distance based on the possibility to insert the body or one of body parts inside the dangerous area before the protective device trips.

C = 8 (d - 14) for devices with resolution ≤ 40mm

C = 850 mm for devices with resolution > 40mm

**NOTE:** K value is:

2000 mm/s if the calculated value of S is ≤ 500 mm

1600 mm/s if the calculated value of S is > 500 mm

When devices with > 40 mm resolution are used, the height of the top beam has to be  $\geq 900$  mm ( $H_2$ ) from machine supporting base while the height of the bottom beam has to be  $\leq 300$  mm ( $H_1$ ).  
If the safety light curtain must be mounted in a horizontal position (Fig.4), the distance between the dangerous area and the most distant optical beam must be equal to the value calculated using the following formula:

$$S = 1600 \text{ mm/s } (t_1 + t_2) + 1200 - 0.4 H$$

where:

S = Minimum safety distance in mm

$t_1$  = Response time of the ESPE in seconds (see chapter 10 "Technical data")

$t_2$  = Machine stopping time in seconds

H = Beam height from the ground; it should be less than 1000 mm

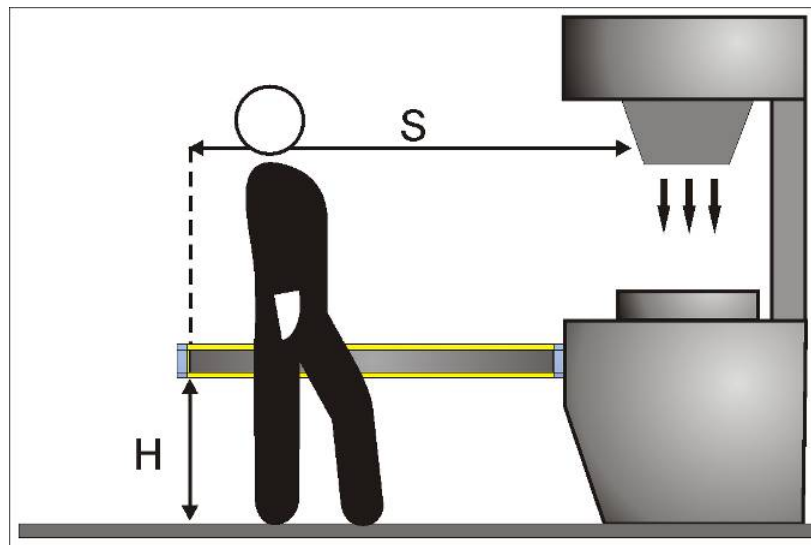

Fig. 4

Practical examples:

Let's suppose to have a light curtain with height = 600 mm

- 1) To calculate the distance of the device from the ESPE, in a vertical position, the following formula is used:

$$S = K * T + C$$

where:

T = t<sub>1</sub> + t<sub>2</sub>

t<sub>1</sub> = ESPE response time + SE-SR2 relay release time (max 80 ms)

t<sub>2</sub> = Machine total stopping time

d = Resolution of the device

C = 8 \* (d - 14) for devices with resolution <= 40 mm

C = 850 for devices with resolution > 40 mm

In all cases, if K = 2000mm/sec then S will be > 500 mm. Distance will have then to be recalculated using K = 1600 mm/sec.

	<b>SG2-30-060</b>	<b>SG2-50-060</b>	<b>SG2-90-060</b>
<b>T</b>	0.398 sec	0.393 sec	0.391 sec
<b>C</b>	128 mm	850 mm	850 mm
<b>S</b>	764.8 mm	1478.8 mm	1475.6 mm

- 2) To calculate the distance of the device from the ESPE, in a horizontal position, the following formula is used:

$$S = 1600 * T + 1200 - 0.4 * H$$

where:

H = Beam min. height from ground 15 \* (d - 50)

d = Resolution of the device

		<b>SG2-50-060</b>	<b>SG2-90-060</b>
<b>T</b>	-	0.3 sec	0.391 sec
<b>H</b>	-	0 mm	600 mm
<b>S</b>	-	1828.8 mm	1585.6 mm



**WARNING:** the reference standard is EN-999 "Machine safety - the positioning of the protective device based on the approaching speed of the human body".  
This information is just an indication and a kind of summary.  
For safety distance correct calculation, it is compulsory to refer to the whole EN-999 standard.

#### 1.4. Typical applications

The safety light curtains of the SG2 series are used in all automation fields where the control and protection of the access to dangerous areas are necessary.

In particular, they are used to stop the moving of mechanical parts in:

- Automatic machines;
- Machines for packaging, material handling, storing;
- Weaving machines, wood working machines, ceramic working machines;
- Automatic and semiautomatic assembly lines;
- Automatic warehouses.

 **In food industry applications, DATALOGIC AUTOMATION Technical Service has to verify the compatibility of the material of the safety light curtain housing with any chemical agents used in the production process.**

##### **Example 1: Hand protection on moulding machine**

In order to protect the light curtain against dust and humidity, the IP69K protective enclosure is used.

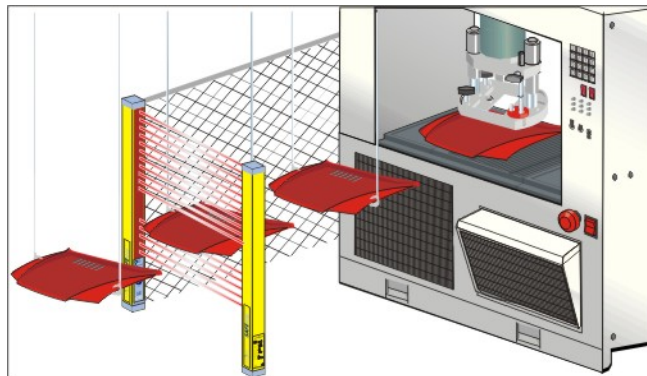

The aim is to prevent operator hands from being squashed during the final product stacking process. In addition, the solution must not interfere with the manufacturing process. Working premises are characterised by a humidity of 85% and a temperature of 25 °C.

Moreover, washing with cold high-pressure waterjets is frequent, as well as the use of alkaline detergents or acids. Cold water rinsing jets (5 - 10 °C) are also used at a pressure of 40 bar.

##### Solution:

IP69K protection, made of a PMMA acrylic tube with v4a stainless steel caps, offers an effective solution without trapping dirt or contamination. The cap's O'ring prevents water or dirt from entering the tube and at the same time, prevents also internal condensation. The cable connection is protected and fixed by a PG gland that prevents water or dirt from entering the tube.

##### Advantages:

the IP69K protective enclosure (optional) ensures a reliable protection of the light curtains even in extreme environmental conditions. Not only does the IP69K protective enclosure meet hygiene, washing resistance, availability and safety requirements, but also ergonomic and productivity requirements, as the protected area remains always accessible when the machine is stopped.

**Example 2: Cooling and air conditioning systems**

Cooling and air conditioning systems, as well as automotive equipment and components, are checked inside a machine to detect possible leaks using a helium mass spectrometer. The point where these parts are positioned inside the measuring chamber, requires a Type 2 protection ensuring space reduction and safe access to the protected area.

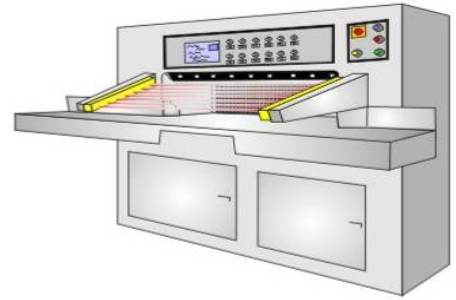
**Solution:**

SG2 series safety light curtain represents is the ideal solution considering the requirements and application. The test machine is immediately stopped even when just one of the light curtain beams is interrupted.

**Advantages:**

the SG2 light curtain meets the customer needs when easy access is necessary in presence of machine stops. Easy installation, configuration and use are other advantages.

**Example 3: Automatic warehouses**

Operator protection in automatic warehouses.

The SG2 Type 2 light curtain represents the ideal solution to protect the operator from hand squashing, abrasion and loss, or parts of it due to the moving parts.

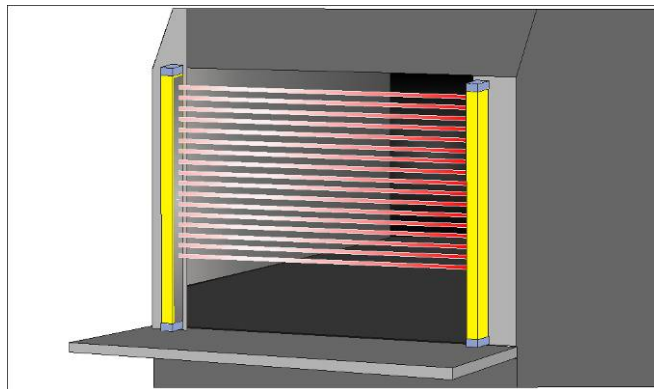
**Solution:**

the SG2 safety light curtain series represents the ideal solution if the safety requirements and the application are considered. When even just one of the light curtain beams is interrupted, the carousel is immediately stopped.

**Advantages:**

he SG2 light curtain meets the customer's needs when easy access is necessary in presence of machine stops. Easy installation, configuration and use are other advantages.

## 1.5. Safety information



For a correct and safe use of the safety light curtains of the SG2 series, the following points must be observed:

- The stopping system of the machine must be electrically controlled.
- This control system must be able to stop the dangerous movement of the machine within the total machine stopping time T as per paragraph 1.3.3, and during all working cycle phases.
- Mounting and connection of the safety light curtain must be carried out by qualified personnel only, according to the indications included in the special sections (refer to sections 2; 3; 4; 5) and in the applicable standards.
- The safety light curtain must be securely placed in a particular position so that access to the dangerous zone is not possible without the interruption of the beams (refer section 2 "Installation mode").
- The personnel operating in the dangerous area must be well trained and must have adequate knowledge of all the operating procedures of the safety light curtain.
- The TEST button must be located outside the protected area because the operator must check the protected area during all Test operation.
- The RESET/RESTART button must be located outside the protected area because the operator must check the protected area during all Reset/Restart operations.

Please carefully read the instructions for the correct functioning before powering the light curtain.

## 2. INSTALLATION MODE

### 2.1. Precautions to be observed for the choice and installation of the device



Make sure that the protection level assured by the SG2 device (Type 2) is compatible with the real danger level of the machine to be controlled, according to EN 954-1 and EN13849.

- The outputs (OSSD) of the ESPE must be used as machine stopping devices and not as command devices (the machine must have its own START command).
- The dimension of the smallest object to be detected must be larger than the resolution level of the device.
- The ESPE must be installed in a room complying with the technical characteristics indicated in chapter 10 "*Technical data*".
- Do not place the device near intense and/or flashing light sources and, in particular, close to receiving unit front surface.
- Strong electromagnetic disturbance might negatively affect device operation. Should this be the case contact DATALOGIC AUTOMATION Technical Service.
- The operating distance of the device can be reduced in presence of smog, fog or airborne dust.
- A sudden change in environment temperature, with very low minimum peaks, can generate a small condensation layer on the lenses and so jeopardise functioning.

## 2.2. General information on device positioning

Pay special care when positioning the safety light curtain so to offer effective protection. The device should be installed in such a way that the dangerous area can only be entered after detecting the sensitive area.



Fig.5a shows some examples of possible access to the machine from the top and the bottom sides. These situations may be very dangerous and so the installation of the safety light curtain at sufficient height in order to completely cover the access to the dangerous area (Fig.5b) becomes necessary.

**NO**

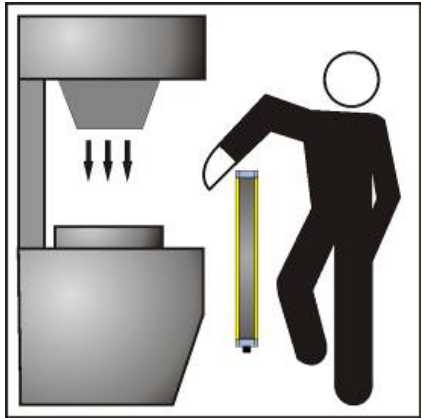

Fig.5a



**YES**



Fig.5b

Under standard operating conditions, machine starting must not be possible while operators are inside the dangerous area.



When the installation of the safety light curtain very near to the dangerous area is not possible, a second light curtain must be mounted in a horizontal position in order to prevent any lateral access, as shown in Fig.6b.



If the operator is able to enter the dangerous area, an additional mechanical protection must be mounted to prevent the access.

**NO**

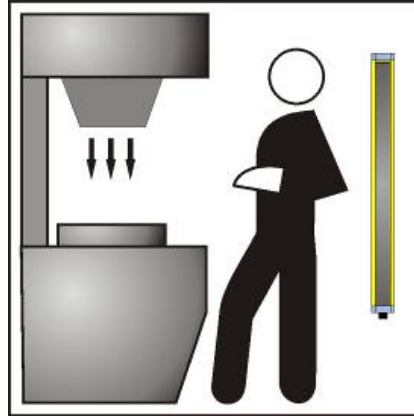

**Fig.6a**



**YES**

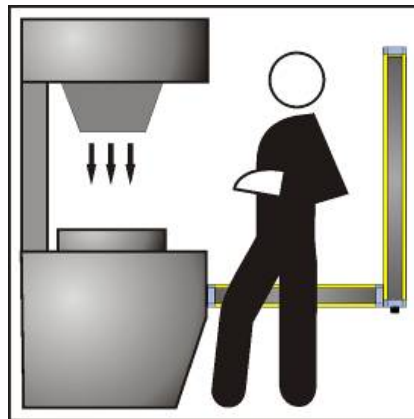

**Fig.6b**

**2.2.1. Minimum installation distance**

Refer to par.1.3.3. "Minimum installation distance"

**2.2.2. Minimum distance from reflecting surfaces**

Reflecting surfaces placed near the light beams of the safety device (over, under or laterally) can cause passive reflections. These reflections can compromise the recognition of an object inside the controlled area.

However, if the **RX** receiver detects a secondary beam (reflected by the side-reflecting surface) the object might not be detected, even if the object interrupts the main beam.

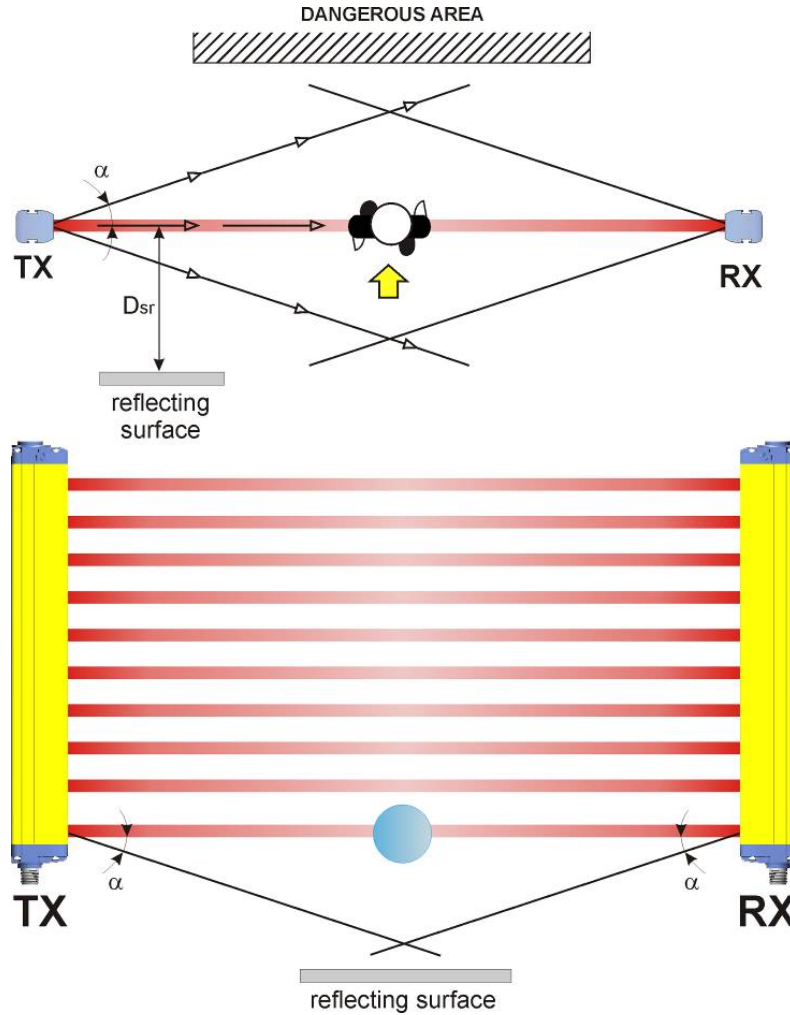

**Fig. 7**

It is thus important to perfectly align the safety light curtain according to the minimum distance from reflecting surfaces.

The minimum distance depends on:

- Working distance between emitter (TX) and receiver (RX) = operating distance
- Real opening angle of ESPE (EAA); especially:

**for ESPE type 2 EAA = 10° (α = 5°)**

Diagram of Fig. 8 shows the min. distance from the reflecting surface (Dsr), based on the operating distance:

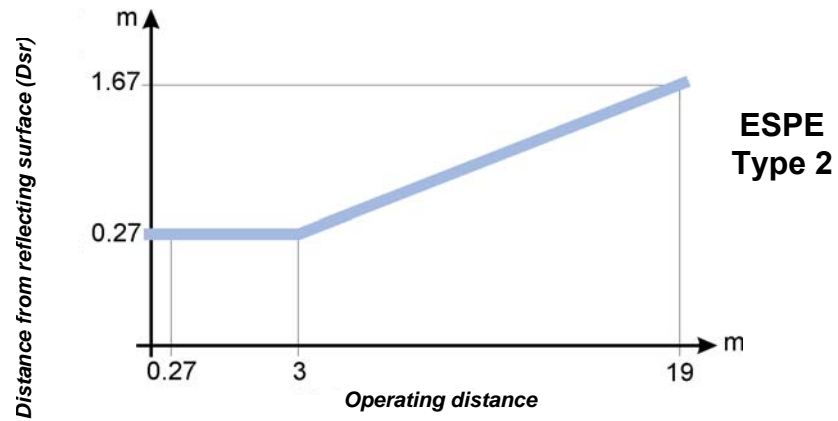

**Fig. 8**

The formula to get Dsr is the following:

$$D_{sr} (m) = 0.27$$

for op. distances < 3 m

$$D_{sr} (m) = 0,5 \text{ operating distance (m)} \times \text{tg } 2\alpha$$

for oper. distances ≥ 3 m

**2.2.3. Emitter and receiver orientation**

The two units shall be installed parallel to each other, with the beams orthogonal respect to the emitting and receiving directions, with the connectors positioned in the same manner.

The configurations shown in Fig. 9 must be avoided:

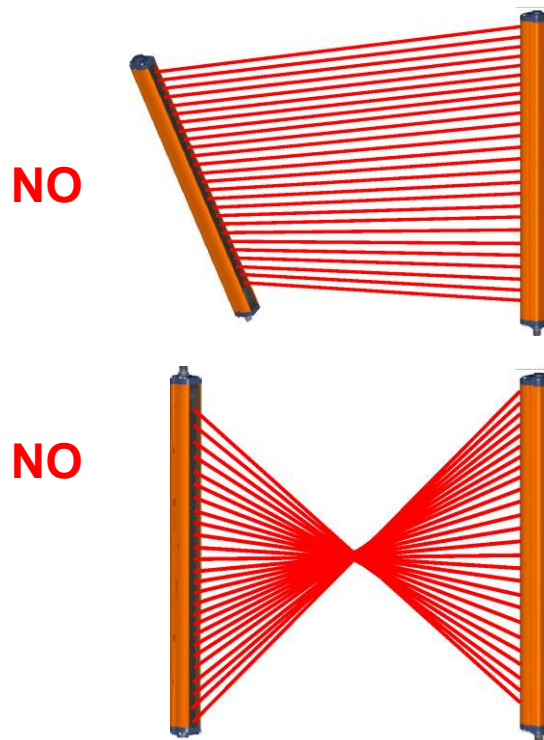
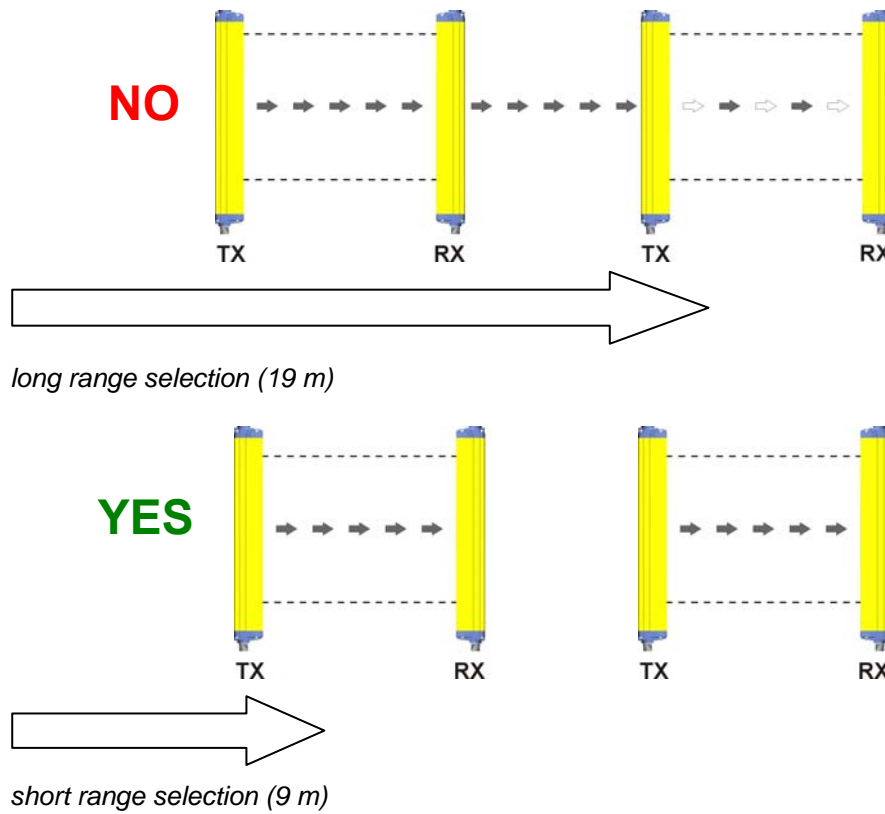

**Fig.9**

**2.2.4. Installation of several adjacent safety light curtains**

When several safety devices must be installed in adjacent areas, interferences between the emitter of one device and the receiver of the other must be avoided. The safety light curtain SG2-E is equipped with a selectable range to reduce interferences between adjacent curtains by selecting short range. See par. 6.5 for the selection and operation.

Fig.10 provides an example of possible interferences between different devices and possible solutions.



**Fig.10**

The following solutions show alternative installation examples to be possibly used depending on application needs.

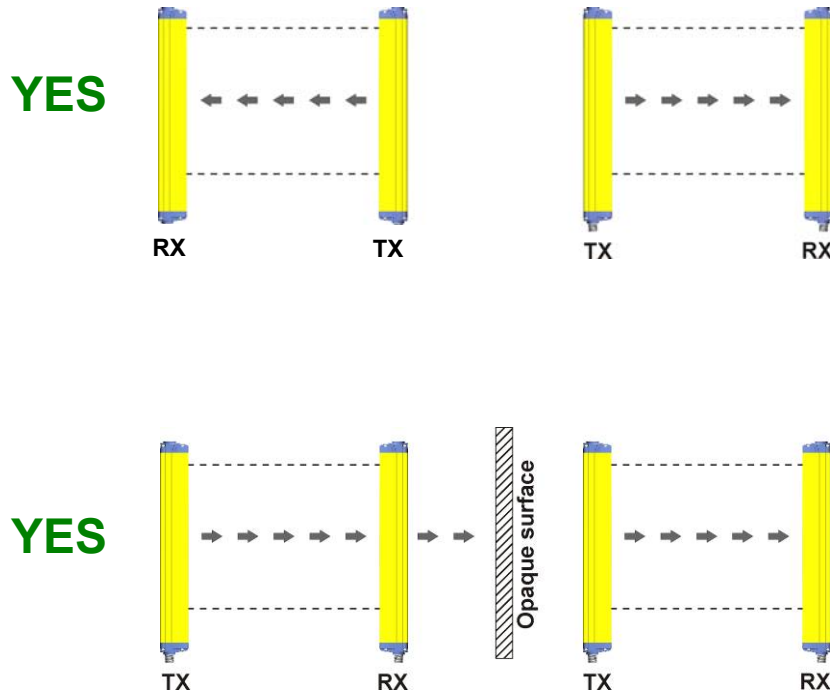
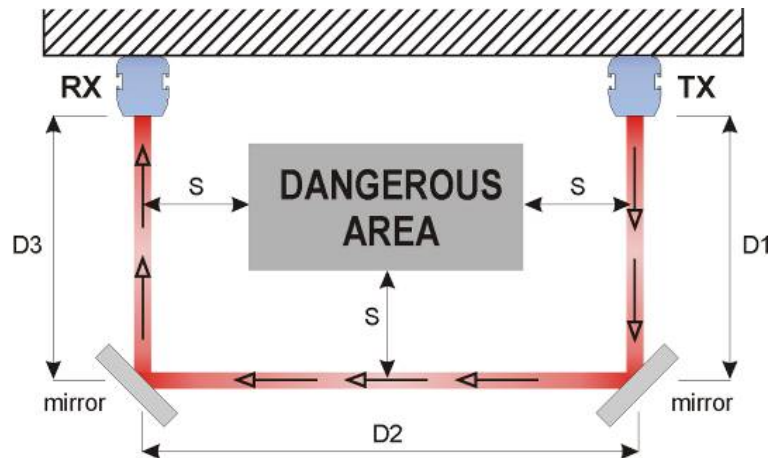

Fig.11

**2.2.5. Use of deviating mirrors**

The control of any dangerous area, with several but adjacent access sides, is possible using only one safety device and well-positioned deviating mirrors.

Fig.12 shows a possible solution to control three different access sides, using two mirrors placed at 45° with respect to the beams.



**Fig. 12**

The operator must respect the following precautions when using the deviating mirrors:

- It is very hard to align the receiver and the transmitter when using deviating mirrors: a tiny angular shift of the mirror is enough to have a misalignment. For this reason the use of DATALOGIC AUTOMATION laser pointer is recommended.
- The minimum safety distance (S) must be respected for each single section of the beams.
- The effective operating range decreases by about 15% by using only one deviating mirror, the percentage further decreases by using 2 or more mirrors (for more details refer to the technical specifications of the mirrors used).

The following table shows the operating distances relating to the number of mirrors used.

number of mirrors	operating distance
1	16.5 m
2	13.7 m
3	11.6 m

- Do not use more than three mirrors for each device.
- The presence of dust or dirt on the reflecting surface of the mirror causes a drastic reduction in the range.

### 2.2.6. Controls after first installation

- The control operations to carry-out after the first installation and before machine start-up are listed hereinafter. The controls must be carried-out by qualified personnel, either directly or under the strict supervision of the person in charge of machinery Safety.

Verify that:

- ESPE remains blocked (➤) intercepting the beams along the protected area using the specific test piece, following the Fig.13 scheme.

**TP30 for light curtains with 30 mm resolution: SG2-30-XX-X**

**TP50 for light curtains with 30 mm resolution: SG2-50-XX-X**

**TP90 for light curtains with 30 mm resolution: SG2-90-XX-X**

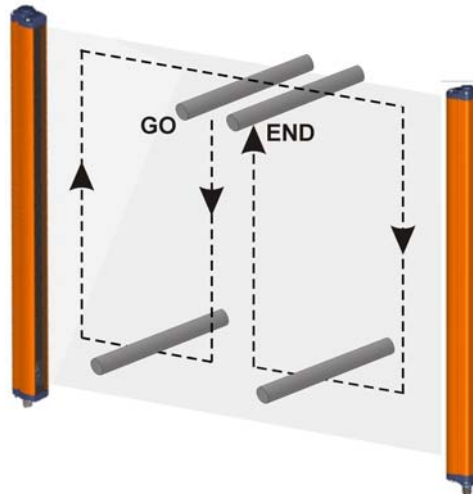

**Fig. 13**

- ESPE has to be correctly aligned, press slightly on the product side in both directions the red LED must not turn on ➤.
- The activation of the TEST function causes the opening of the OSSD outputs (red LED ➤ on and controlled machine stop).
- The response time at machine STOP, including the ESPE and machine response times, must be included in the limits defined in the calculation of the safety distance (refer to section 2 "Installation modes").
- The safety distance between the dangerous parts and ESPE must comply with the requirements indicated in section 2 "Installation modes".
- A person must not access or remain between ESPE and the dangerous parts of the machine.
- Access to the dangerous areas of the machine must not be possible from any unprotected area.
- ESPE must not be disturbed by external light sources, ensuring that it remains in Normal operating function for at least 10-15 minutes and placing the specific test piece in the protected area in the SAFE condition for the same period.
- Verify the correspondence of all the accessory functions, activating them in the different operating conditions.



### 3. MECHANICAL MOUNTING

The emitting (TX) and receiving (RX) units must be installed with the relevant sensitive surfaces facing each other.

The connectors must be positioned on the same side and the distance must be included within the operating range of the model used (see chapter 10 "Technical data").

The two units shall be positioned so as to be aligned and parallel as much as possible. The next step is the fine alignment, as shown in chapter 5 "Alignment Procedure".

Two types of brackets can be used to fix the two units:

#### **Rotating brackets**

Rotating fixing brackets are supplied with all SG2-E models (Fig. 14).

They can be used separately from or together with the angled fixing brackets.

For fixing with rotating brackets, refer to Fig. 14.

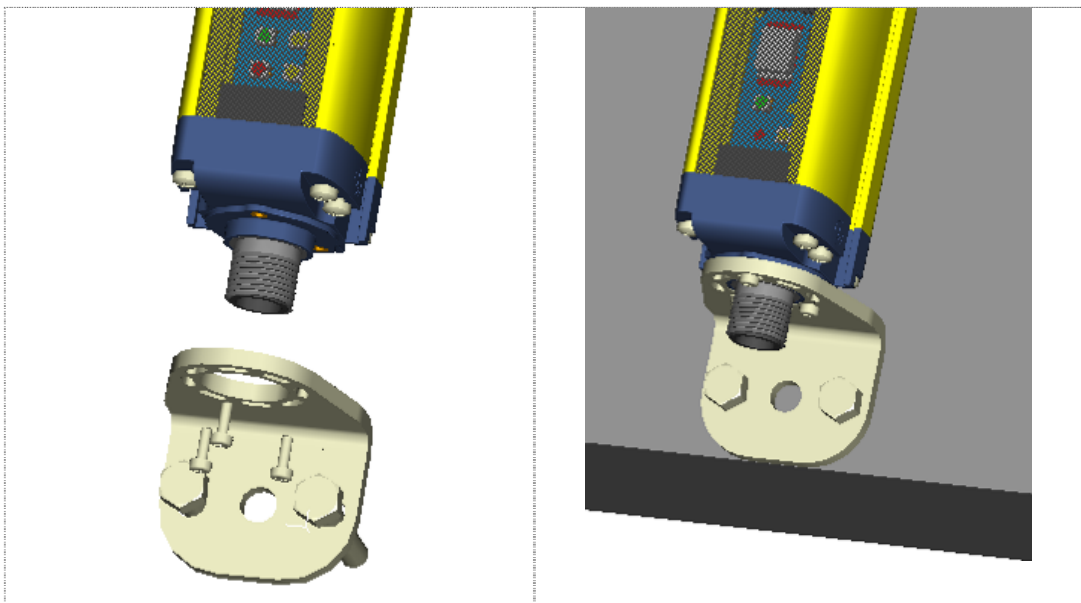
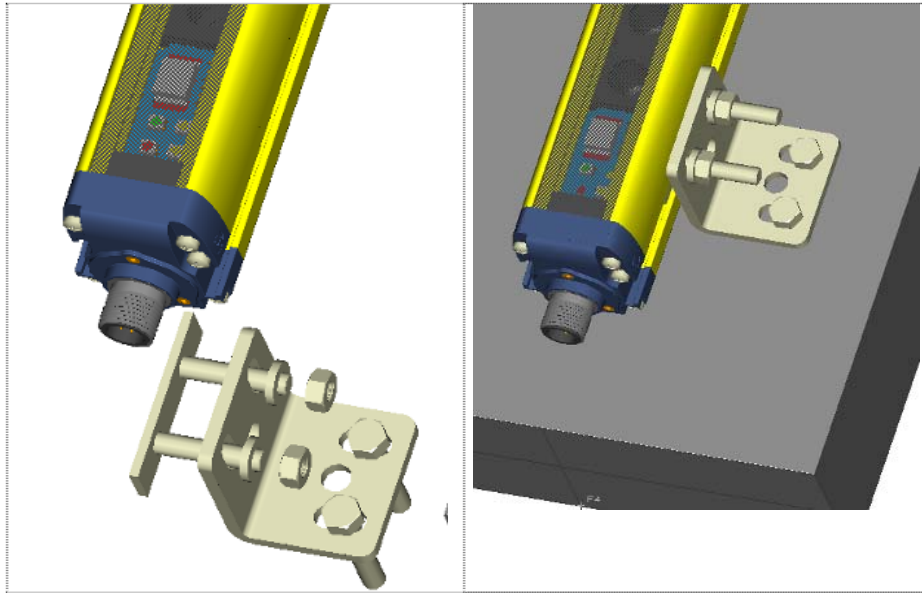

**Fig. 14**

**Angled fixing brackets**

Angled fixing brackets (Fig.15), available upon request, can be used as an alternative or together with rotating brackets.

The rotating supports for the correction of the unit inclination are available on request (see chapter 14 “Accessories”).



**Fig. 15**

Anti-vibration shock absorbers together with fixing brackets are recommended in applications with particularly strong vibrations to reduce the impact of the vibrations.

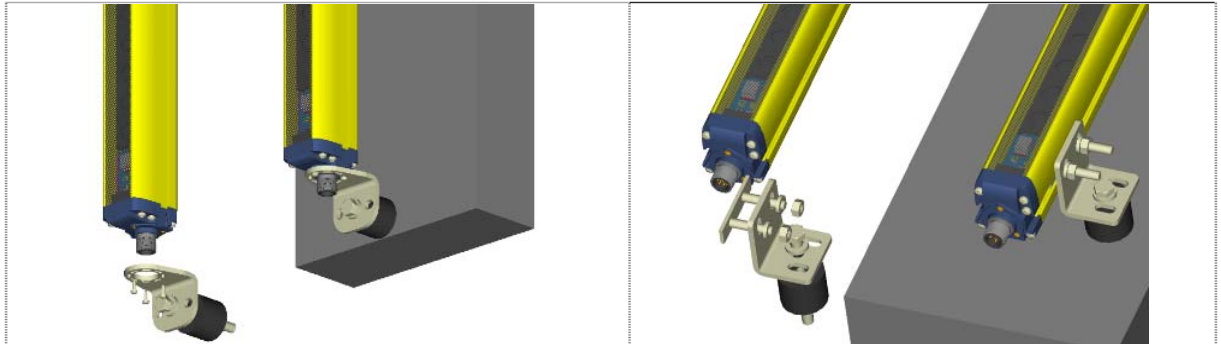

**Fig.16**

Fig.16 and table below show the recommended mounting positions according to the safety light curtain length.

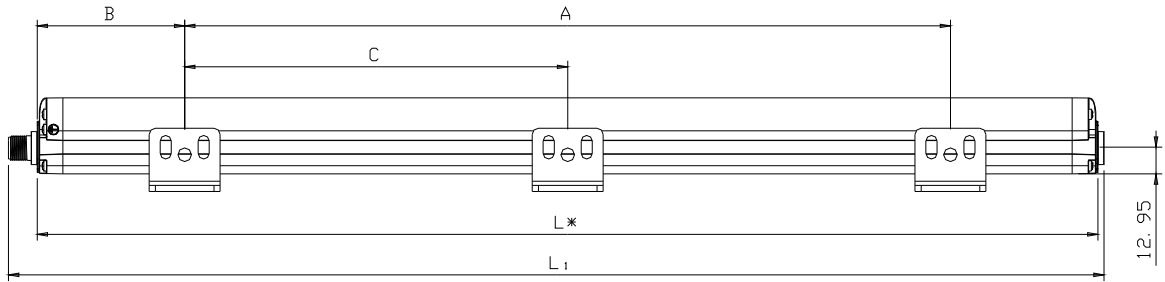

MODELS	L (mm)	A (mm)	B (mm)	C (mm)
<b>SG2-30-015-OO-E-C</b>	216.3	108	54	-
<b>SG2-kk-030-OO-E-C</b>	366.2	216	75	-
<b>SG2-kk-045-OO-E-C</b>	516.3	316	100	-
<b>SG2-kk-060-OO-E-C</b>	666.2	366	150	-
<b>SG2-kk-075-OO-E-C</b>	816.3	466	175	-
<b>SG2-kk-090-OO-E-C</b>	966.2	566	200	-
<b>SG2-kk-105-OO-E-C</b>	1116.2	666	225	-
<b>SG2-kk-120-OO-E-C</b>	1266.3	966	150	483
<b>SG2-kk-135-OO-E-C</b>	1416.2	1066	175	533
<b>SG2-kk-150-OO-E-C</b>	1566.3	1166	200	583
<b>SG2-kk-165-OO-E-C</b>	1716.3	1266	225	633
<b>SG2-kk-180-OO-E-C</b>	1866.3	1366	250	683

kk = Resolution (30mm – 50 mm – 90 mm)

### 4. ELECTRICAL CONNECTIONS

All electrical connections to the emitting and receiving units are made through a male M12 connector, located on the lower part of the two units. For receiver a M12 8-pole connector is used, while for emitter a M12 4-pole connector is used.

**RECEIVER (RX):**

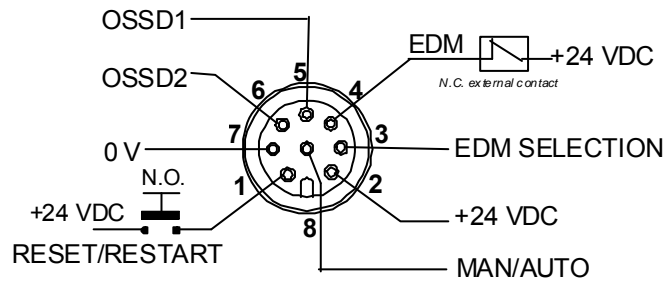

- 1 = white = RESET / RESTART(\*)
- 2 = brown = +24 VDC
- 3 = green = EDM SELECTION
- 4 = yellow = EDM
- 5 = grey = OSSD 1
- 6 = pink = OSSD 2
- 7 = blue = 0 V
- 8 = red = MANUAL/AUTOMATIC RESTART

(\*) automatic RESTART → RESET function  
 manual RESTART → RESTART/RESET function

**EMITTER (TX):**

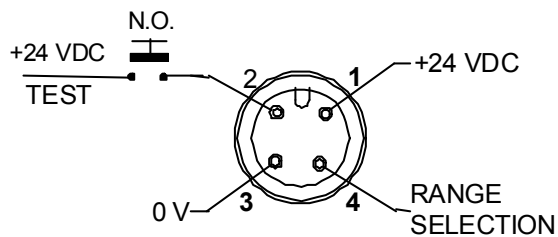

- 1 = brown = +24 VDC
- 2 = white = TEST
- 3 = blue = 0 V
- 4 = black = RANGE SELECTION

Purpose	Connection	Status
TEST	+ 24 Vdc	TEST ON
	Not connected or 0V	TEST OFF
RESET	+ 24 Vdc	RESET ON
	Not connected or 0V	RESET OFF
SELECT RANGE	+ 24 Vdc	short (9 m)
	Not connected or 0V	long (19 m)
EDM	Normally closed Force-guided relay contact	
ENABLE EDM	+ 24 Vdc	EDM OFF
	Not connected or 0V	EDM ON
MAN/AUTO RESTART SELECTION	OSSD1	AUTO RESTART
	OSSD2	MAN RESTART

**4.1. Notes on connections**

For the correct functioning of the SG2 safety light curtains, the following precautions regarding the electrical connections have to be respected:

- Do not place connection cables in contact with or near high-voltage cables and/or cable undergoing high current variations (e.g. motor power supplies, inverters, etc.);
- Do not connect in the same multi-pole cable the OSSD wires of different light curtains;
- The TEST wire must be connected through a N.O. button to the supply voltage of the ESPE.
- The RESET/RESTART wire must be connected through a N.O. button to the supply voltage of the ESPE.



The RESET/RESTART button must be located in such a way that the operator can check the protected area during any test (see chapter 6 “Functioning mode”).

- The device is protected internally against overvoltage and overcurrent: the use of other outer parts is not recommended.

Example: connection to the safety relay.

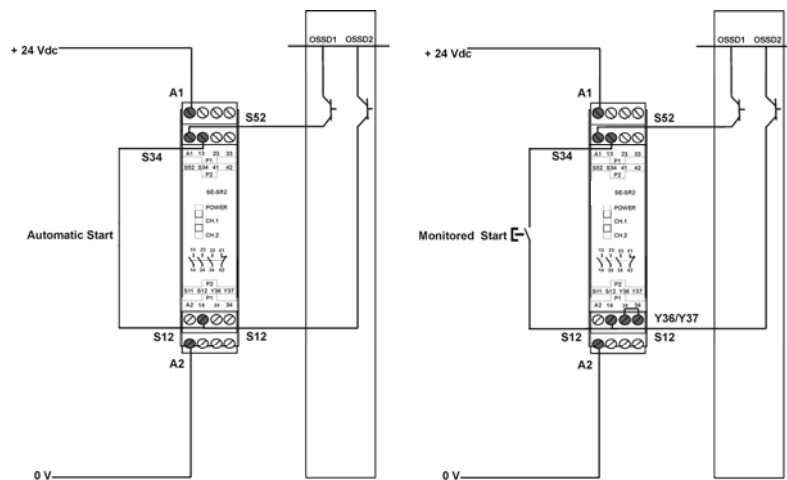

Fig. 17

The figures show the connection between the safety light curtains and the safety relay of the SE-SR2 series functioning in the Automatic Start mode (left side) and Manual Start with monitoring (right side).



- Do not use varistors, RC circuits or LEDs in parallel at relay inputs or in series at OSSD outputs.
- The OSSD1 and OSSD2 safety contacts cannot be connected in series or in parallel, but can be used separately (Fig.18). If one of these configurations is erroneously used, the device enters into the output failure condition (see chapter 7 “Diagnostic functions”).

- Connect both OSSDs to the activating device. Failure to connect an OSSD to the activating device jeopardises the system safety degree that the light curtain has to control.

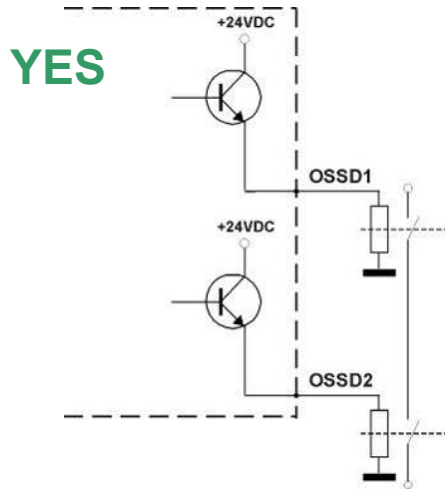

Fig. 18

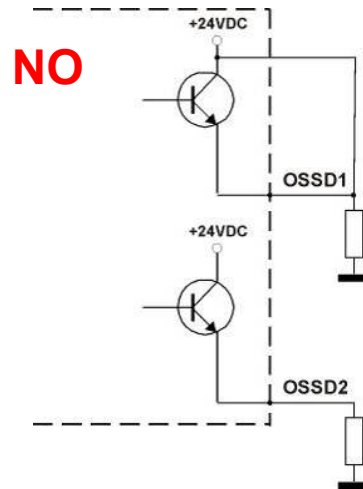

Fig. 19

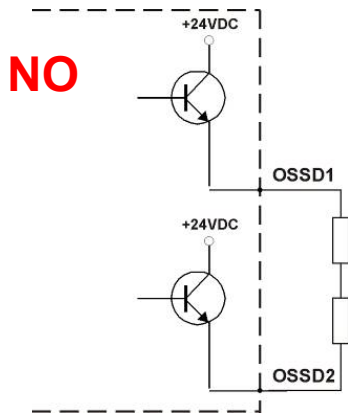

Fig. 20

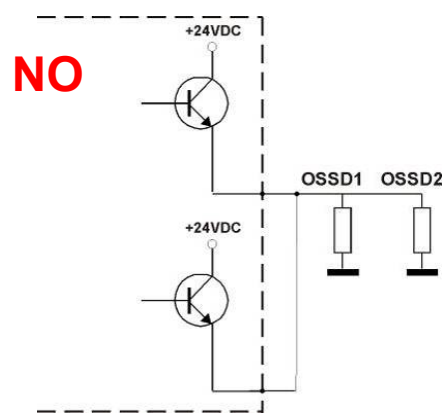

Fig. 21

#### 4.2. Earth connection

SG2 safety light curtain units are preset for easy ground connection. A special compartment, positioned onto caps and marked with the special symbol shown in Figure 22, allows connection with ground cable by means of an additional screw coming with the equipment.

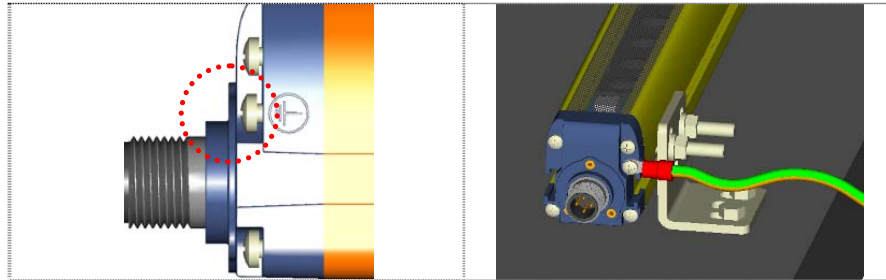

Fig. 22

Ground connection configuration is the most common and guarantees the best immunity against electromagnetic disturbances. SG2-B can function even without ground connection.

This condition has to be carefully evaluated according to the EMC disturbance immunity and necessary insulation class considering the plant or entire system where the light curtain is installed.

- The ground connection of the two units is not necessary for Class III, while the use of a duly-insulated low-voltage feeder type SELV or PELV is compulsory. In this case, we recommend covering the earth symbol present on the caps of the two units with a blank sticker.
- The ground connection of the two units is compulsory for Class I, while the use of a duly-insulated feeder type SELV or PELV is not compulsory but anyway recommended.

The following table is a summary of SG2-E electrical protections.

Electrical protections	Class I	Class III
Ground Connection	Compulsory	Not necessary
Ground connection symbol	Compulsory	Not necessary
Power supply by generators SELV / PELV	Recommended	Compulsory



### 5. ALIGNMENT PROCEDURE

The alignment between the emitting and the receiving units is necessary to obtain the correct functioning of the light curtain.

A good alignment prevents outputs instability caused by dust or vibrations.

The alignment is perfect if the optical axes of the first and the last emitting unit's beams coincide with the optical axes of the corresponding elements of the receiving unit.

The beam used to synchronise the two units is the first after the connector. SYNC is the optics connected with this beam and LAST is the optics connected to the last beam after the SYNC unit..

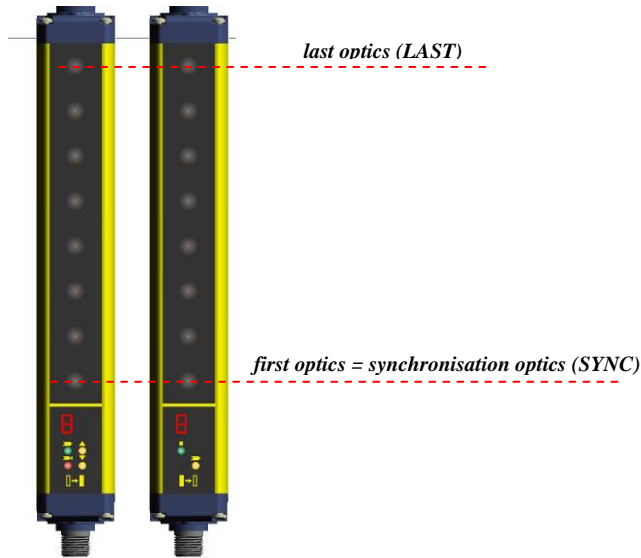

Fig. 23

Signals are clearly identified through symbols allowing immediate reading, independent of bars directions. A short description of the signalling LEDs is necessary to avoid misunderstandings.

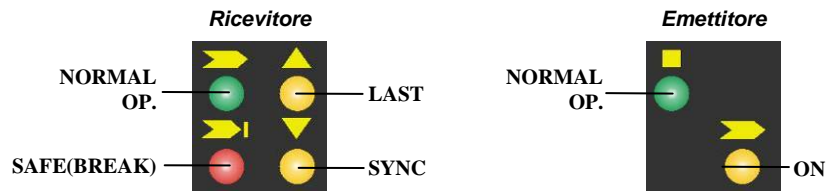

Fig. 24

The standard installation described hereinafter is the one shown in Fig. 24, *i.e.* with the bar assembled with the connectors pointing down.

**5.1. Correct alignment procedure**

The light curtain alignment can be effected only after having completed the mechanical installation and the electrical connections as described above. Check alignment results with given table.

**NOTE:** To enter alignment mode select the function as described in chapter 6.6.

Display	LED ➡ NORMAL OP.	LED ➡  SAFE (BREAK)	LED yellow ▼ SYNC	LED yellow ▲ LAST	Condition	Alignment status
	OFF	ON	ON	ON	Sync NOK Last NOK	NO align.
			OFF	ON	Sync OK Last NOK	
			OFF	OFF	Sync OK Last OK Middle optics NOK	
	ON	OFF	OFF	OFF	Each beam is over the min. operating threshold and the number of beam over the threshold is included between 0 and 25%	MINIMUM align.
	ON	OFF	OFF	OFF	Each beam is over the min. operating threshold and the number of beam over the threshold is included between 25 and 50%	
	ON	OFF	OFF	OFF	Each beam is over the min. operating threshold and the number of beam over the threshold is included between 50 and 75%	
	ON	OFF	OFF	OFF	Each beam is over the min. operating threshold and the number of beam over the threshold is included between 75 and 100%	MAXIMUM align.

- A Keep the receiver in a steady position and set the emitter until the yellow LED (▼ SYNC) is OFF. This condition shows the effective alignment of the first beam (synchronisation beam).
- B Rotate the emitter, pivoting on the lower optics axis, until the yellow LED (▲ LAST) is OFF.

**NOTE:** Ensure that the green LED (➡ NORMAL OP.) is steady ON.

- C Delimit the area in which the green LED (➡) is steady through some micro adjustments - for the first and then for the second unit - so to have the maximum alignment (4) and then place both units in the centre of this area.
- D Fix the two units firmly using brackets.
  - Verify that the green LED (➡) on the RX unit is ON and beams are not interrupted, then verify that the red LED SAFE (BREAK)➡| turns ON if even one single beam is interrupted (condition where an object has been detected).
  - This verification shall be made with the special cylindrical “Test Piece” having a size suitable to the resolution of the device used (refer paragraph 2.2.6 “Controls after first installation”).
- E Switch OFF and ON the device in standard operating mode.

The alignment level is monitored also during device normal operation mode via display (see chapter 7.2).

Once the curtain has been aligned and correctly fastened, the display signal is useful both to check the alignment and show a change in the environmental conditions (occurrence of dust, light disturbance and so on) via signal level monitoring.

## 6. FUNCTIONING MODE

### 6.1. Reset mode

The interruption of a beam due to an opaque object causes the opening of OSSD outputs and the stop of the safety light curtain, SAFE (BREAK) condition ➡I.

ESPE standard operation can be reset (OSSD safety contact closing = NORMAL OP.condition ➡) in two different ways:

- Automatic restart - After its activation ESPE resets to standard operating condition once the object has been removed from the controlled area.
- Manual restart - After its activation ESPE resets to standard operating condition only once the reset function has been enabled and provided that the object has been removed from the controlled area. This condition, called interlock, is signalled on the display (see chapter 7.2).



**WARNING!** Carefully assess risk conditions and reset modes. In applications protecting access to dangerous areas, the automatic reset mode is potentially unsafe if it allows the operator to pass completely beyond the sensitive area. In this case, the manual reset or, for example, the manual reset of the SE-SR2 relay (chapter 4.1 "Notes on connections") might be necessary.

#### Time chart (Manual Restart)

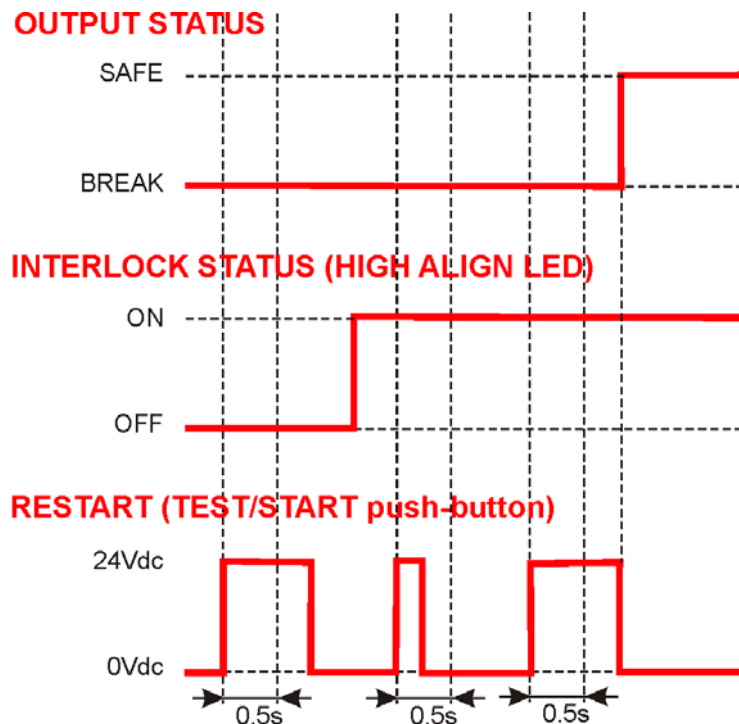

The automatic or manual restart can be selected by connecting the receiver (see chapter 4 "Electrical connections")

**6.2. Test function**

The TEST function can be activated by keeping a normally open external contact (TEST push-button), open for at least 0.5 seconds. The TEST signal is active high.

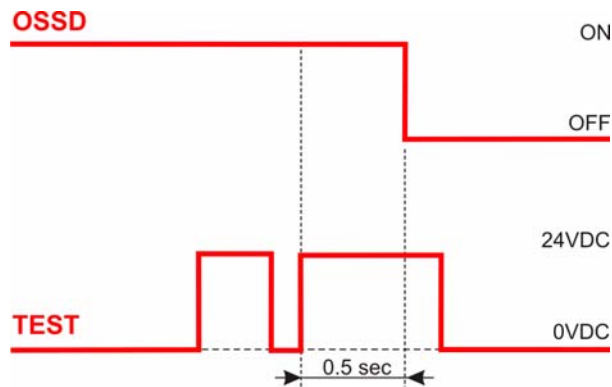

**6.3. Reset function**

The RX light curtain has a RESET function which is activated after an internal error. The reset can be made only in case of optical error, OSSD error EDM or manual/automatic restart selection (See chapter 7 “Diagnostic Functions”). The RESET function can be activated by keeping a normally open external contact (RESET/RESTART push-button), open for at least 5 seconds. The RESET signal is active high.

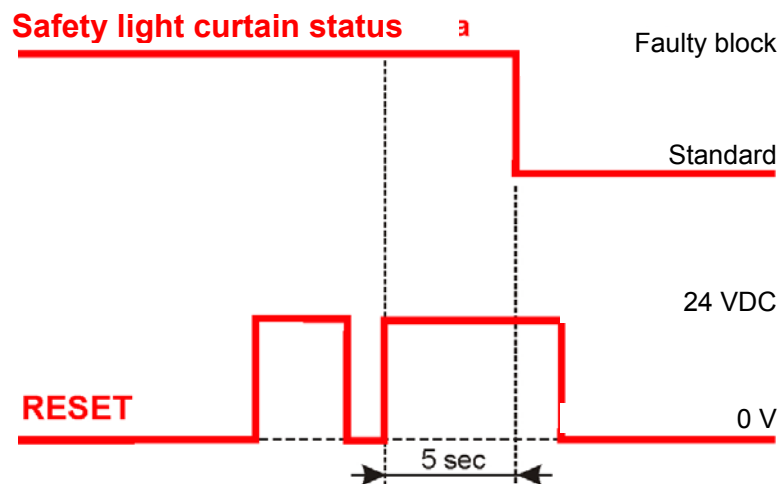

#### 6.4. EDM function

The light curtain has a function for monitoring actuation external devices (EDM). This function can be enabled or deactivated.

##### EDM enabled:

- Disconnect or connect to the ground pin 3 of receiver M12 8-pole connector (EDM enabling = ON).
- Connect EDM input (pin 4 of M12 8-pole – RX) to a 24 VDC normally closed contacts of the device to be monitored.

**NOTE:** The decimal dot on the display shows that the function is enabled.

##### EDM deactivated:

- Connect to 24 VDC pin 3 of receiver M12 8-pole connector (EDM enabling = OFF).
  - Disconnect or connect to the ground EDM input (pin 4 of M12 8-pole - RX).
- This function checks normally closed contact switch on OSSD status change.

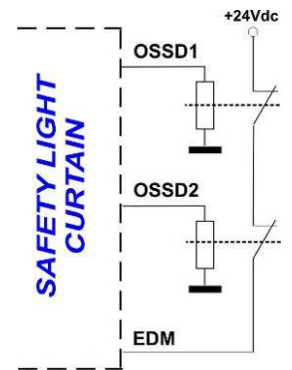

#### OSSD STATUS

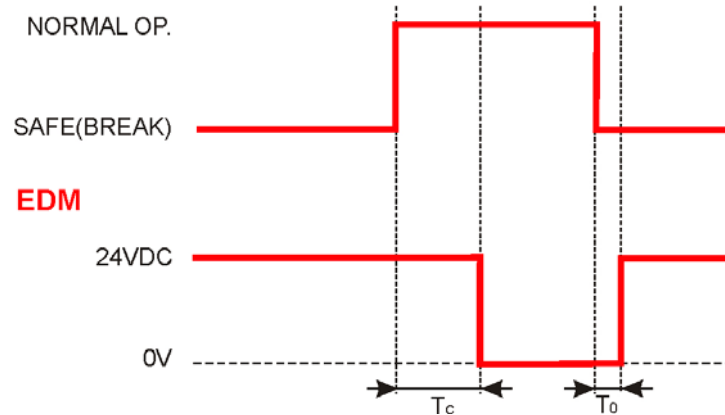

$T_C \geq 350$  msec: 350 msec: time after OSSD OFF-ON switch when EDM test is performed.

$T_0 \geq 100$  msec: time after OSSD ON-OFF switch when EDM test is performed.

### 6.5. Anti-interference function for range reduction

The safety light curtain SG2-E can reduce interferences between adjacent curtains by selecting short range.

Range is selected by connecting pin 4 of the transmitter M12 4-pole connector of the emitter (as specified in chapter.4).

Connect pin 4 to +24V for short range - up to 9 m- or 0V for long range - up to 19 m (i.e. standard setting).

Range setting is accepted on device switching on, no range changes are allowed during standard operating conditions.

Range setting is displayed on the transmitter during the initialisation stage: "L" stands for long range, whereas "S" stands for short range.

**WARNING!** Check for interference from adjacent devices before starting standard operating mode. Position the interfering device beyond short range limit.

## 6.6. Alignment aid function

SG2-E is equipped with a system which informs the operator on the alignment obtained. The alignment function can be activated when powering the device, by keeping the normally open RESET/RESTART contact closed for at least 0.5 seconds (see Figure 24).

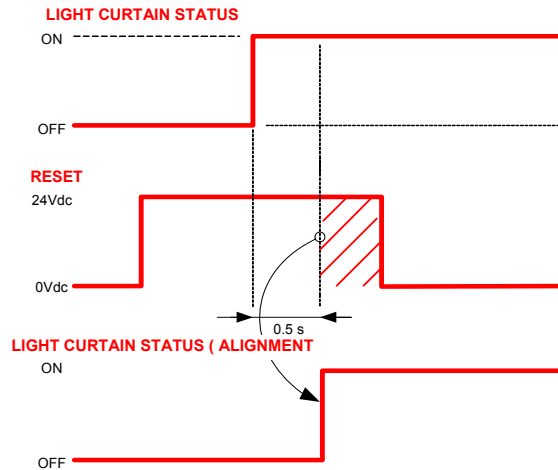

Fig. 25

When the best alignment has been reached, restart the device to return to the standard operating mode, by powering off and on again the Rx unit.

The alignment level is monitored also during device standard operating mode via display (see par 7.2). Once the curtain has been aligned and correctly fastened, the display signal is useful both to check the alignment and show any changes in the environmental conditions (occurrence of dust, light disturbance and so on).

NOTE: OSSDs are not active on the alignment mode.



## 7. DIAGNOSTIC FUNCTIONS

### 7.1. User interface

Curtain operating status is displayed onto a 1-digit display both on receiver and transmitter. SG2-E also has four LEDs on the receiver and two LEDs on the emitter. Fig.26 shows all LEDs signalling modes ON, OFF and blinking.

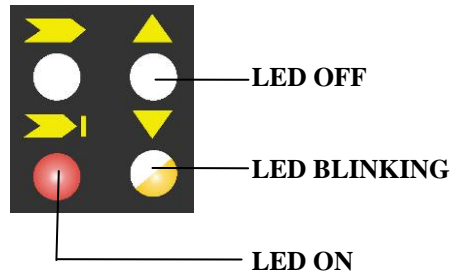

Fig. 26

**7.2. Diagnostic messages**







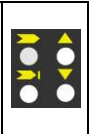
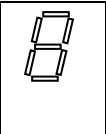





The operator is able to check the main causes of the system stop and failure, using the same LEDs used for visualising the functions.

For Receiver:

Function	Status	Meaning	LED	DIGIT
Normal operation	Alignment	See chapter.5		
	TEST (red ON)	Light curtain being tested, the OSSD status must be OFF		
	Emission (OSSD ON) (green ON)	Light curtain working and in normal operation conditions		
	Interruption (OSSD OFF) (red ON)	Light curtain working and in safety block conditions.		
	Interlock Beams free (red ON yellow ON)	Interlock curtain waiting for restart. OSSD status must be OFF		
	Interlock Beams interrupted (red ON yellow ON)	Light curtain interlocked, OSSD status must be OFF		
	Signal level	Minimum (1 bar) Medium (2 bar) Maximum (3 bar)		
	EDM enabled	EDM function is selected		
Function	Type	Check and repair	LED	DIGIT
Error status	OSSD error (red ON)	Check OSSD connections. Make sure that they are not in contact with one another or with the supply cables, then Reset. If the failure continues contact DATALOGIC AUTOMATION		
	Internal error (red ON)	Switch OFF and switch ON the power supply circuit. If the failure continues contact DATALOGIC AUTOMATION		
	Optical error (red ON)	Reset. If the failure continues contact DATALOGIC AUTOMATION		
	EDM error (red ON)	Check EDM connections and lines. If the failure continues contact DATALOGIC AUTOMATION		
	Restart selection error (red ON)	Check the man/auto restart connection. If the failure continues contact DATALOGIC AUTOMATION		

	No power supply (LEDs OFF)	Check connections and input voltage value. If the failure continues contact DATALOGIC AUTOMATION	 A square icon containing six circles arranged in two columns of three. The left column has two yellow arrows pointing right, and the right column has two yellow triangles pointing up and one yellow triangle pointing down.	 A simple line drawing of a battery with a positive terminal on the right side.
--	-------------------------------	--	---	--

For Emitter:

Function	Status	Meaning	LED	DIGIT
Normal operation	TEST (green ON)	Light curtain being tested, the OSSD status on the receiver shall be OFF		
	Emission (rated range) (green ON yellow ON)	Light curtain working in normal operating conditions		
	Emission (reduced range) (green ON yellow ON)	Light curtain working in normal operating conditions		
Function	Type	Check and repair	LED	DIGIT
Error status	Internal error (green ON)	Switch OFF and switch ON the power supply circuit. If the failure continues contact DATALOGIC AUTOMATION		
	Optical error (green ON)	Switch OFF and switch ON the power supply circuit. If the failure continues contact DATALOGIC AUTOMATION		
	No power supply (LEDs OFF)	Check connections and input correct value. If the failure continues contact DATALOGIC AUTOMATION		

## 8. PERIODICAL CHECKS

The following is a list of recommended check and maintenance operations that should be periodically carried out by qualified personnel.

Check that:

- The ESPE stays locked (➤) during beam interruption along the entire protected area, using the suitable "Test Piece". (\*)
- The ESPE is correctly aligned. Gently press onto product side in both directions. The red LED should remain OFF ➤.
- Enabling the TEST function, the OSSD outputs should open (the red LED ➤ is ON and the controlled machine stops).
- The response time upon machine STOP (including response time of the ESPE and of the machine) is within the limits defined for the calculation of the safety distance (see chapter 2 "Installation mode").
- The safety distance between the dangerous areas and the ESPE are in accordance with the instructions included in chapter 2 "Installation mode".
- Access of a person between ESPE and machine dangerous parts is not possible nor is it possible for him/her to stay there.
- Access to the dangerous area of the machine from any unprotected area is not possible.
- The ESPE and the external electrical connections are not damaged.

The frequency of checks depends on the particular application and on the operating conditions of the safety light curtain.

(\*) according to the Fig.13 scheme

Verify that:

- ESPE remains blocked (➤) intercepting the beams along the protected area using the specific test piece, following the Fig.12 scheme.

**TP30 for light curtains with 30 mm resolution: SG2-30-XX-X**

**TP50 for light curtains with 50 mm resolution: SG2-50-XX-X**

**TP90 for light curtains with 90 mm resolution: SG2-90-XX-X**

### 8.1. General information and useful data



Safety MUST be a part of our conscience.

The safety devices fulfil their safety function only if they are correctly installed, in accordance with the Standards in force.

If you are not certain to have the expertise necessary to install the device in the correct way, DATALOGIC AUTOMATION Customer Service is at your disposal to carry out the installation.

The device uses fuses that are not self-resetting. Consequently, in presence of short-circuits causing the cut-off of these fuses, both units shall be sent to DATALOGIC AUTOMATION service department.

A power failure caused by interferences may cause the temporary opening of the outputs, but the safe functioning of the light curtain will not be compromised.

### 8.2. Warranty

DATALOGIC AUTOMATION guarantees each brand new SG2

system, under standard use conditions, against manufacturing defects in material and workmanship for a period of 36 (thirty-six) months from the date of manufacturing.

DATALOGIC AUTOMATION will not be liable for any damages to persons and things caused by failure to stick to the correct installation modes and device use.



Warranty validity is subject to the following conditions:

- User shall notify DATALOGIC AUTOMATION the failure within thirty-six months from product manufacturing date.
- Failure or malfunction shall not have been originated directly or indirectly by:
  - use for unsuitable purposes;
  - failure to comply with the intended use prescriptions;
  - negligence, unskillfulness, wrong maintenance;
  - repairing, changes, adaptations not made by DATALOGIC AUTOMATION personnel, tampering with the device, etc.;
  - accidents or crashes (even due to transportation or by force majeure causes);
  - other causes not depending from DATALOGIC AUTOMATION.

If the device does not work, send both units (receiver and emitter) to DATALOGIC AUTOMATION. The Customer is responsible for all transport charges and damage risks or material loss during transport, unless otherwise agreed.

All replaced products and parts become a property of DATALOGIC AUTOMATION. DATALOGIC AUTOMATION does not accept any warranty or right other than the above-described ones. No requests for compensation for expenses, activities stop or other factors or circumstances somehow connected to the failure of the product or one of its parts to operate cannot be put forward for any reason.

In case of problems, please contact DATALOGIC AUTOMATION Service Department:

Tel.: +39 051 6765611

Fax.: +39 051 6759324

## **9. DEVICE MAINTENANCE**

SG2 safety light curtains do not require special maintenance operations.

To avoid the reduction of the operative distance, optics protective front surfaces shall be cleaned at regular intervals.

To this end, use soft cotton cloths damped in water; do not apply too much pressure onto the surface so as not to make it dull.

Please do not use on plastic surfaces or light curtain painted surfaces:

- alcohol or solvents
- wool or synthetic cloths
- paper or other abrasive materials

### **9.1. Product disposal**

Under current Italian and European laws, DATALOGIC AUTOMATION is not obliged to take care of product disposal at the end of its life.

DATALOGIC AUTOMATION recommends to dispose of the product in compliance with local laws or contact authorised waste collection centres.

## 10. TECHNICAL DATA

ELECTRICAL DATA	
Power supply (Vdd):	24 Vdc $\pm$ 20
Consumption (TX):	2 W max
Consumption (RX):	3.5 W max (without load)
Outputs:	2 PNP
Short-circuit protection:	1.4 A max
Output current:	0.5 A max / each output
Output voltage – status ON:	Vdd – 1 V min
Output voltage – status OFF	0.2 V max
Capacitive load:	2.2 $\mu$ F @ 24Vdc max
Response times:	See chapter 11
Protected height:	150..1800mm
Safety category:	Type 2
Auxiliary functions:	Reset / Test / EDM / Range selection and manual / Automatic Restart
Electrical protection:	Class I / Class III (see sect.4.2)
Connections:	M12 4 poles for emitter M12 8 poles for receiver
Cables length (for power supply):	50 m. max
OPTICAL DATA	
Emitting light ( $\lambda$ ):	Infrared, LED (950 nm)
Resolution:	30 - 50 - 90 mm
Operating distance:	0.2...19 m
Ambient light rejection:	IEC-61496-2
MECHANICAL AND ENVIRONMENTAL DATA	
Operating temperature:	0...+ 55 °C
Storage temperature:	-25...+ 70 °C
Humidity:	15...95 % (no condensation)
Mechanical protection:	IP 65 (EN 60529)
Vibrations:	Width 0.35 mm, Frequency 10 ... 55 Hz 20 sweep per axis, 1octave/min (EN 60068-2-6)
Shock resistance:	16 ms (10 G) 1,000 shocks per axis (EN 60068-2-29)
Housing material:	Painted aluminium (yellow RAL 1003)
Front side material:	PMMA
Caps material:	PC MAKROLON
Weight:	1,3 kg per linear metre



**11. LIST OF AVAILABLE MODELS**

<b>Model</b>	<b>Protected Height (mm)</b>	<b>No. Beams</b>	<b>Response time (msec)</b>	<b>Resolution (mm)</b>
SG2-30-015-OO-E-C	150	8	8	30
SG2-30-030-OO-E-C	300	16	9	30
SG2-30-045-OO-E-C	450	24	11	30
SG2-30-060-OO-E-C	600	32	12	30
SG2-30-075-OO-E-C	750	40	14	30
SG2-30-090-OO-E-C	900	48	15	30
SG2-30-105-OO-E-C	1050	56	17	30
SG2-30-120-OO-E-C	1200	64	18	30
SG2-30-135-OO-E-C	1350	72	20	30
SG2-30-150-OO-E-C	1500	80	21	30
SG2-30-165-OO-E-C	1650	88	23	30
SG2-30-180-OO-E-C	1800	96	24	30
SG2-50-030-OO-E-C	300	9	9	50
SG2-50-045-OO-E-C	450	13	10	50
SG2-50-060-OO-E-C	600	17	11	50
SG2-50-075-OO-E-C	750	21	12	50
SG2-50-090-OO-E-C	900	25	14	50
SG2-50-105-OO-E-C	1050	29	15	50
SG2-50-120-OO-E-C	1200	33	16	50
SG2-50-135-OO-E-C	1350	37	17	50
SG2-50-150-OO-E-C	1500	41	18	50
SG2-50-165-OO-E-C	1650	45	19	50
SG2-50-180-OO-E-C	1800	49	20	50
SG2-90-030-OO-E-C	300	5	9	90
SG2-90-045-OO-E-C	450	7	10	90
SG2-90-060-OO-E-C	600	9	11	90
SG2-90-075-OO-E-C	750	11	12	90
SG2-90-090-OO-E-C	900	13	13	90
SG2-90-105-OO-E-C	1050	15	14	90
SG2-90-120-OO-E-C	1200	17	15	90
SG2-90-135-OO-E-C	1350	19	16	90
SG2-90-150-OO-E-C	1500	21	17	90
SG2-90-165-OO-E-C	1650	23	18	90
SG2-90-180-OO-E-C	1800	25	19	90

	<i>EN ISO 13849-1</i>	<i>EN 954-1</i>	<i>EN IEC 61508</i>	<i>EN IEC 62061</i>	<i>Prob. of danger failure/hour</i>	<i>Life span</i>	<i>Mean Time to Dangerous Failure</i>	<i>Average Diagnostic Coverage</i>	<i>Safe Failure Fraction</i>	<i>Hardware Fault Tolerance</i>
<b>Product</b>	<b>PL</b>	<b>CAT</b>	<b>SIL</b>	<b>SIL CL</b>	<b>PFHd (1/h)</b>	<b>T1 (years)</b>	<b>MTTFd (years)</b>	<b>DC</b>	<b>SFF</b>	<b>HF T</b>
SG2-30-015-OO-E-C	d	2	2	2	1,04E-08	20	273	97,50%	98,40%	0
SG2-30-030-OO-E-C	d	2	2	2	1,04E-08	20	273	97,50%	98,40%	0
SG2-30-045-OO-E-C	d	2	2	2	1,04E-08	20	273	97,50%	98,40%	0
SG2-30-060-OO-E-C	d	2	2	2	1,04E-08	20	273	97,50%	98,40%	0
SG2-30-075-OO-E-C	d	2	2	2	1,04E-08	20	273	97,50%	98,40%	0
SG2-30-090-OO-E-C	d	2	2	2	1,04E-08	20	273	97,50%	98,40%	0
SG2-30-105-OO-E-C	d	2	2	2	1,04E-08	20	273	97,50%	98,40%	0
SG2-30-120-OO-E-C	d	2	2	2	1,04E-08	20	273	97,50%	98,40%	0
SG2-30-135-OO-E-C	d	2	2	2	1,04E-08	20	273	97,50%	98,40%	0
SG2-30-150-OO-E-C	d	2	2	2	1,04E-08	20	273	97,50%	98,40%	0
SG2-30-165-OO-E-C	d	2	2	2	1,04E-08	20	273	97,50%	98,40%	0
SG2-30-180-OO-E-C	d	2	2	2	1,04E-08	20	273	97,50%	98,40%	0
SG2-50-030-OO-E-C	d	2	2	2	1,04E-08	20	273	97,50%	98,40%	0
SG2-50-045-OO-E-C	d	2	2	2	1,04E-08	20	273	97,50%	98,40%	0
SG2-50-060-OO-E-C	d	2	2	2	1,04E-08	20	273	97,50%	98,40%	0
SG2-50-075-OO-E-C	d	2	2	2	1,04E-08	20	273	97,50%	98,40%	0
SG2-50-090-OO-E-C	d	2	2	2	1,04E-08	20	273	97,50%	98,40%	0
SG2-50-105-OO-E-C	d	2	2	2	1,04E-08	20	273	97,50%	98,40%	0
SG2-50-120-OO-E-C	d	2	2	2	1,04E-08	20	273	97,50%	98,40%	0
SG2-50-135-OO-E-C	d	2	2	2	1,04E-08	20	273	97,50%	98,40%	0
SG2-50-150-OO-E-C	d	2	2	2	1,04E-08	20	273	97,50%	98,40%	0
SG2-50-165-OO-E-C	d	2	2	2	1,04E-08	20	273	97,50%	98,40%	0
SG2-50-180-OO-E-C	d	2	2	2	1,04E-08	20	273	97,50%	98,40%	0
SG2-90-030-OO-E-C	d	2	2	2	1,04E-08	20	273	97,50%	98,40%	0
SG2-90-045-OO-E-C	d	2	2	2	1,04E-08	20	273	97,50%	98,40%	0
SG2-90-060-OO-E-C	d	2	2	2	1,04E-08	20	273	97,50%	98,40%	0
SG2-90-075-OO-E-C	d	2	2	2	1,04E-08	20	273	97,50%	98,40%	0
SG2-90-090-OO-E-C	d	2	2	2	1,04E-08	20	273	97,50%	98,40%	0
SG2-90-105-OO-E-C	d	2	2	2	1,04E-08	20	273	97,50%	98,40%	0
SG2-90-120-OO-E-C	d	2	2	2	1,04E-08	20	273	97,50%	98,40%	0
SG2-90-135-OO-E-C	d	2	2	2	1,04E-08	20	273	97,50%	98,40%	0
SG2-90-150-OO-E-C	d	2	2	2	1,04E-08	20	273	97,50%	98,40%	0
SG2-90-165-OO-E-C	d	2	2	2	1,04E-08	20	273	97,50%	98,40%	0
SG2-90-180-OO-E-C	d	2	2	2	1,04E-08	20	273	97,50%	98,40%	0

## 12. OVERALL DIMENSIONS

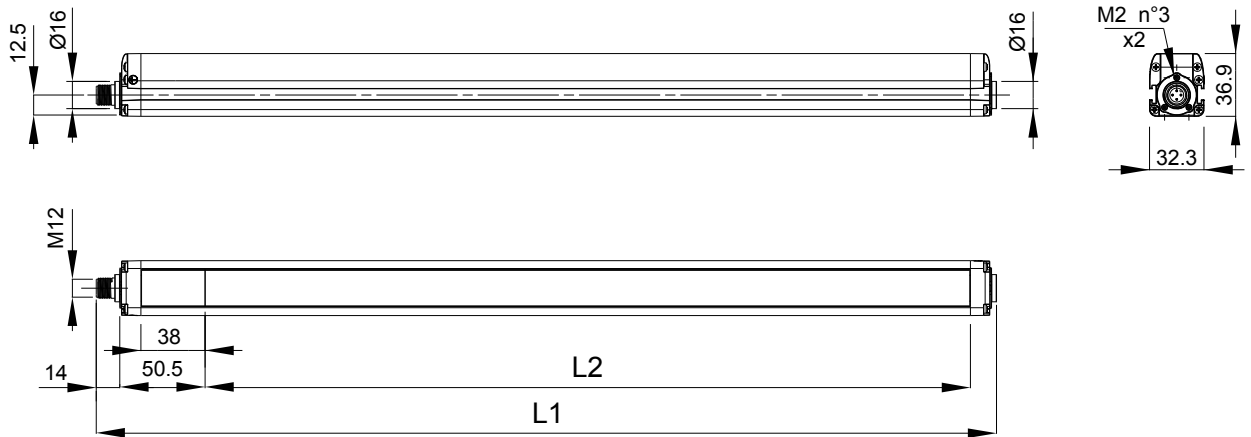

MODEL	$L_1$	$L_2$
SG2-30-015-OO-E-C	233.3	153.3
SG2-xx-030-OO-E-C	383.2	303.2
SG2-xx-045-OO-E-C	533.2	453.3
SG2-xx-060-OO-E-C	683.2	603.2
SG2-xx-075-OO-E-C	833.2	753.3
SG2-xx-090-OO-E-C	983.2	903.2
SG2-xx-105-OO-E-C	1133.2	1053.2
SG2-xx-120-OO-E-C	1283.3	1203.3
SG2-xx-135-OO-E-C	1433.2	1353.2
SG2-xx-150-OO-E-C	1583.3	1503.3
SG2-xx-165-OO-E-C	1733.3	1653.3
SG2-xx-180-OO-E-C	1883.3	1803.3

kk = Resolution (30mm – 50 mm – 90 mm)

### 13. OUTFIT

#### Rotating fixing bracket

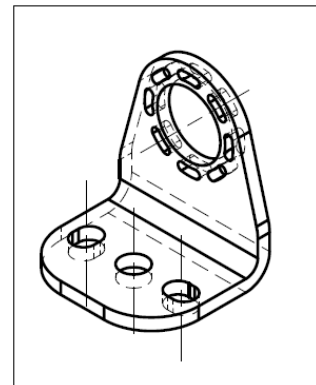
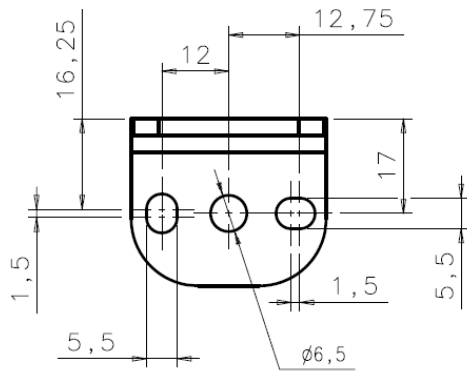
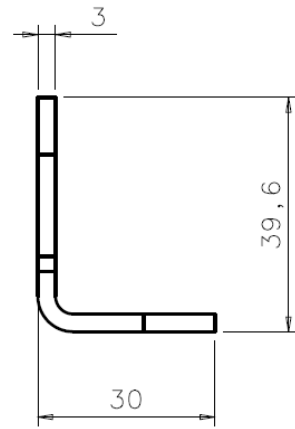
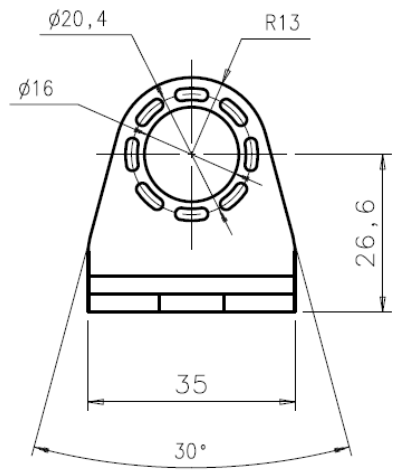

## 14. ACCESSORIES

### 14.1. Angled fixing bracket

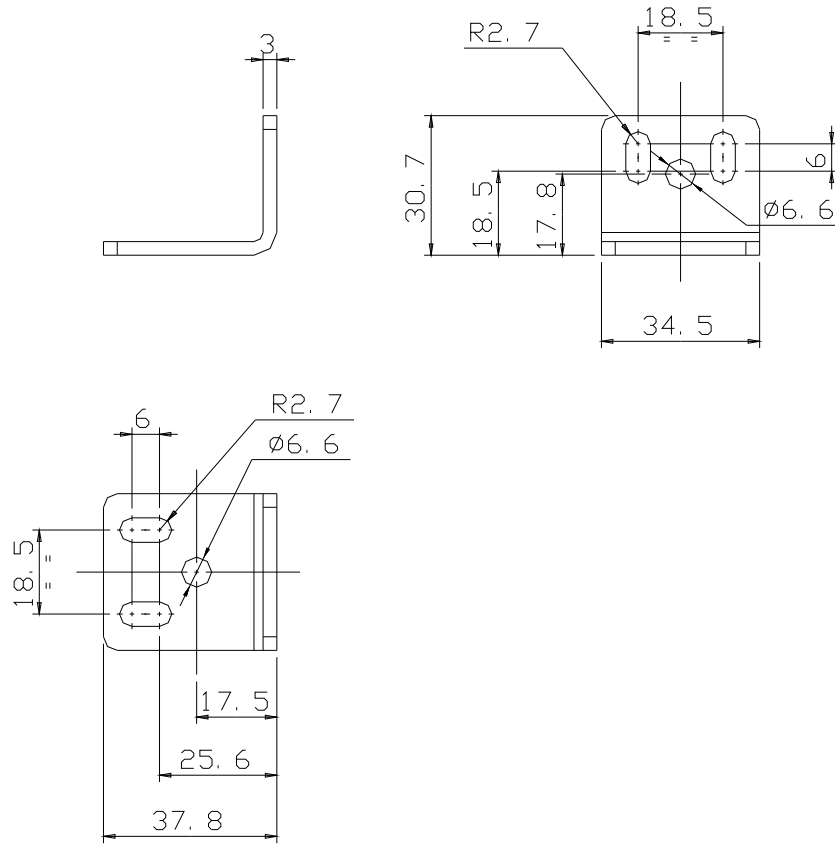

MODEL	DESCRIPTION	CODE
ST-KSTD	Fixing bracket (kit 4 pz.)	95ACC1670

14.2. Angled fixing bracket mounting

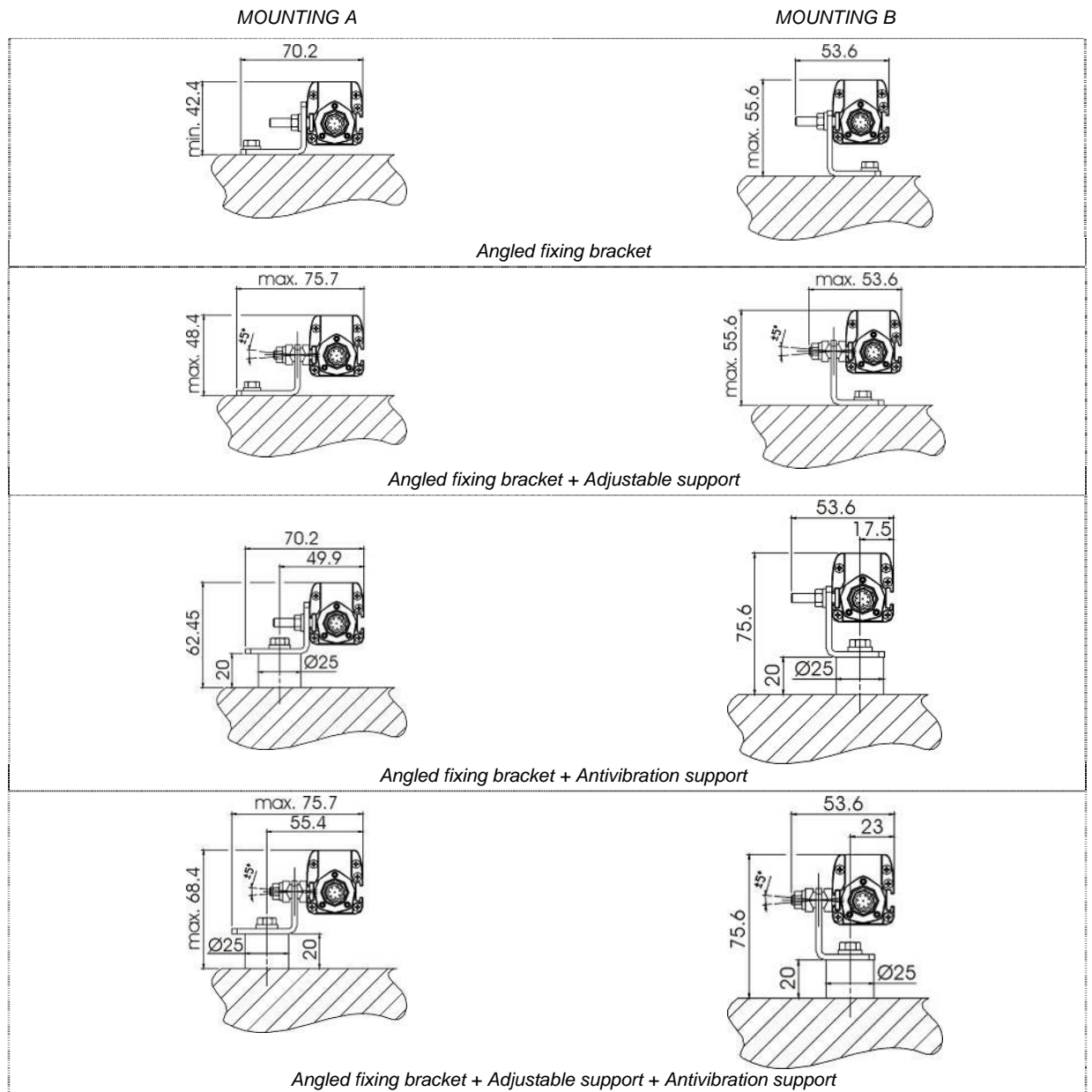

MODEL	DESCRIPTION
ST-KSTD	Fixing brackets for angle mounting (4 pcs kit)
ST-K4AV	Antivibration support (4 pcs kit)
ST-K6AV	Antivibration support (6 pcs kit)
ST-K4OR	Supporti orientabili (kit 4pz.)
ST-K6OR	Supporti orientabili (kit 6pz.)

14.3. Deviating mirrors

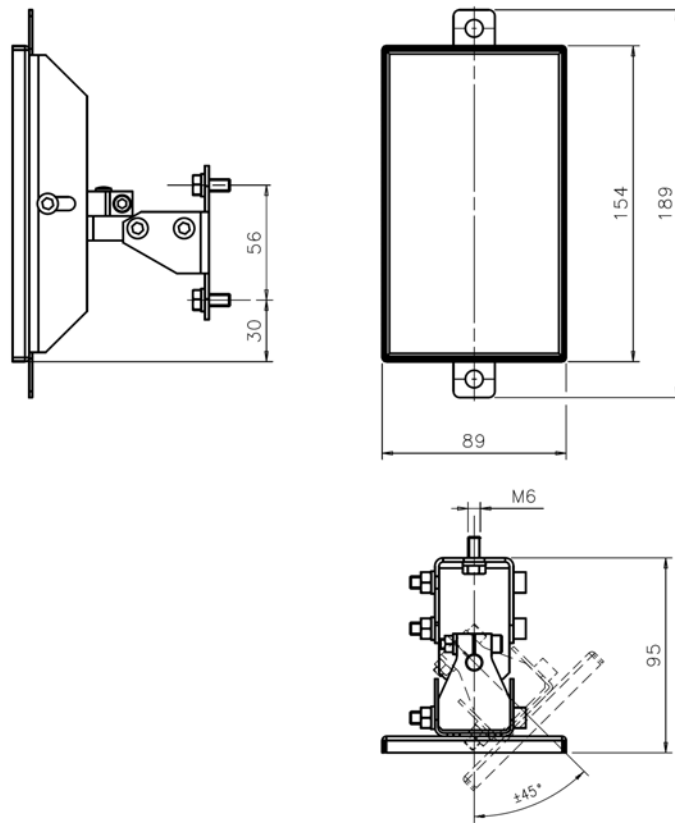

MODEL	DESCRIPTION	CODE
SG-DM 150	Deviating mirror H = 150 mm	95ASE1670

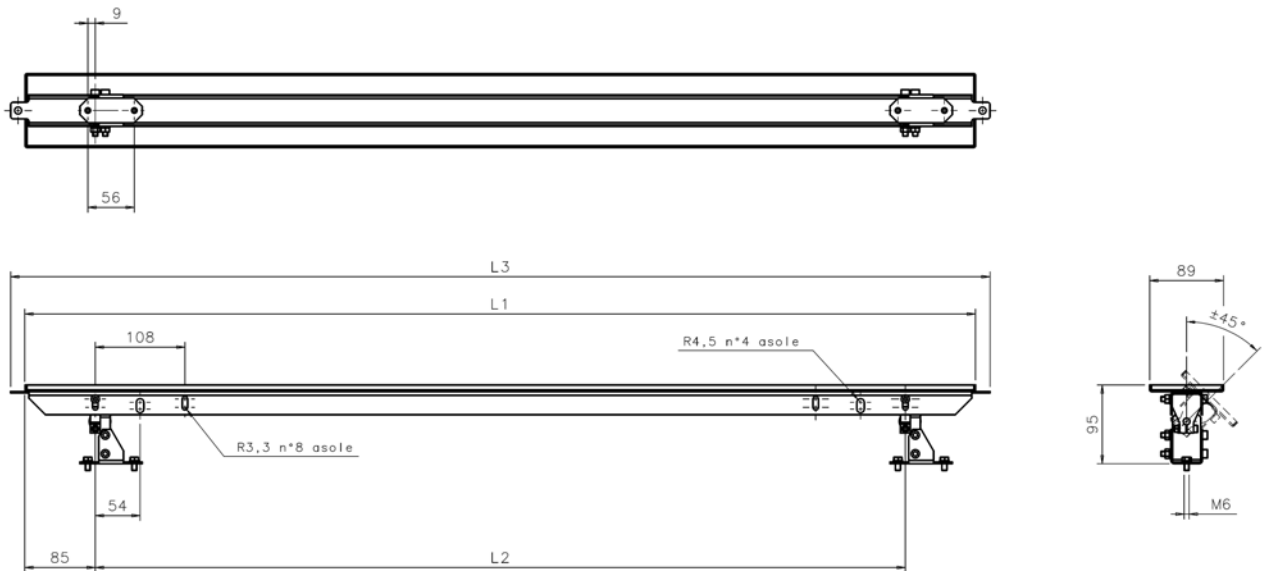

MODEL	DESCRIPTION	L <sub>1</sub> (mm)	L <sub>2</sub> (mm)	L <sub>3</sub> (mm)	CODE
SG-DM 600	Deviating mirror H = 600 mm	545	376	580	95ASE1680
SG-DM 900	Deviating mirror H = 900 mm	845	676	880	95ASE1690
SG-DM 1200	Deviating mirror H = 1200 mm	1145	976	1180	95ASE1700
SG-DM 1650	Deviating mirror H = 1650 mm	1595	1426	1630	95ASE1710
SG-DM 1900	Deviating mirror H = 1900 mm	1845	1676	1880	95ASE1720

14.4 Columns and floor stands

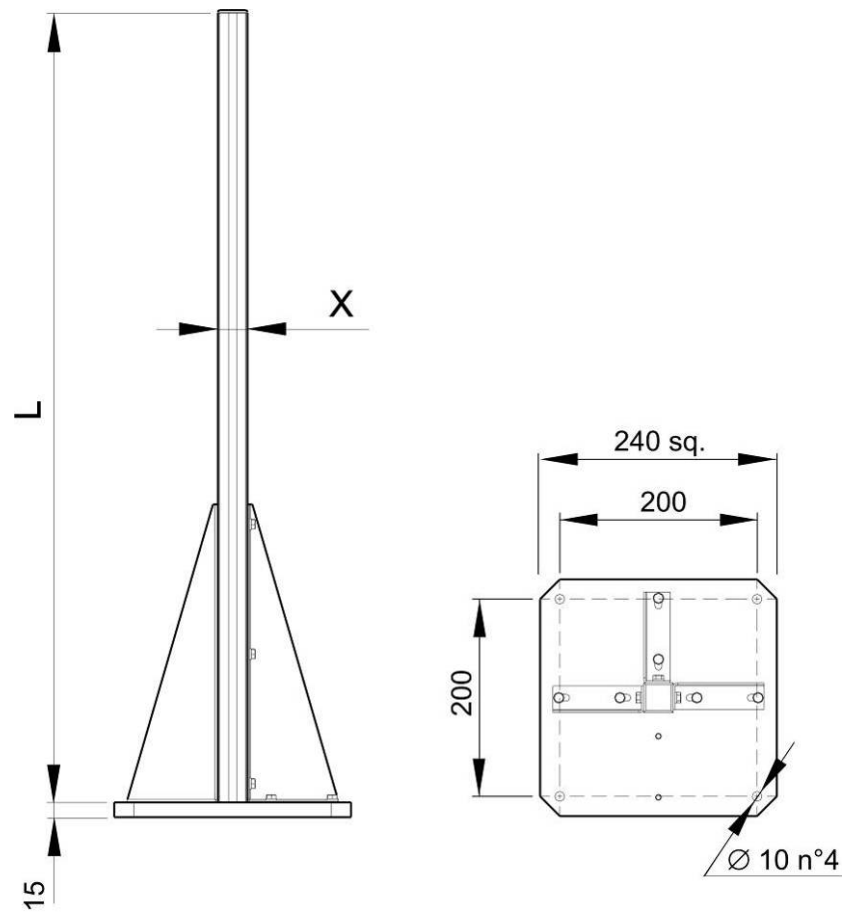

MODEL	DESCRIPTION	L (mm)	X (mm)	CODE
SE-S 800	Column and floor stand H = 800 mm	800	30x30	95ACC1730
SE-S 1000	Column and floor stand H = 1000 mm	1000	30x30	95ACC1740
SE-S 1200	Column and floor stand H = 1200 mm	1200	30x30	95ACC1750
SE-S 1500	Column and floor stand H = 1500 mm	1500	45x45	95ACC1760
SE-S 1800	Column and floor stand H = 1800 mm	1800	45x45	95ACC1770



**14.5. Protective stands**

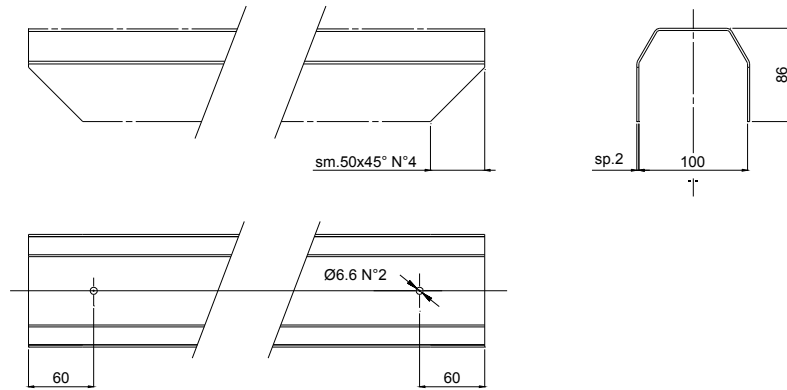

MODEL	DESCRIPTION	L (mm)	CODE
SE-P 150	Protective stand H = 273 mm	273	95ACC1780
SE-P 300	Protective stand H = 420 mm	420	95ACC1790
SE-P 450	Protective stand H = 567 mm	567	95ACC1800
SE-P 600	Protective stand H = 714 mm	714	95ACC1810
SE-P 750	Protective stand H = 861 mm	861	95ACC1820
SE-P 800	Protective stand H = 969 mm	969	95ACC1830
SE-P 900	Protective stand H = 1069 mm	1069	95ACC1840
SE-P 1050	Protective stand H = 1155 mm	1155	95ACC1850
SE-P 1200	Protective stand H = 1302 mm	1369	95ACC1860
SE-P 1350	Protective stand H = 1449 mm	1449	95ACC1870
SE-P 1500	Protective stand H = 1596 mm	1596	95ACC1880
SE-P 1650	Protective stand H = 1743 mm	1743	95ACC1890

**14.6. Test piece**

MODEL	DESCRIPTION	CODE
TP-30	Test piece Ø 30 mm	95ASE1650
TP-50	Test piece Ø 50 mm	95ASE1790
TP-90	Test piece Ø 90 mm	95ASE1800

**14.7. Connection cables**

<b>MODEL</b>	<b>DESCRIPTION</b>	<b>CODE</b>
CS-A1-02-U-03	4-pole M12 cable (axial) 3 m	95ASE1120
CS-A1-02-U-05	4-pole M12 cable (axial) 5 m	95ASE1130
CS-A1-02-U-10	4-pole M12 cable (axial) 10 m	95ASE1140
CS-A1-02-U-15	4-pole M12 cable (axial) 15 m	95ASE1150
CS-A1-02-U-25	4-pole M12 cable (axial) 25 m	95ASE1160
CS-A1-03-U-03	5-pole M12 cable (axial) 3 m	95ASE1170
CS-A1-03-U-05	5-pole M12 cable (axial) 5 m	95ASE1180
CS-A1-03-U-10	5-pole M12 cable (axial) 10 m	95ASE1190
CS-A1-03-U-15	5-pole M12 cable (axial) 15 m	95ASE1200
CS-A1-03-U-25	5-pole M12 cable (axial) 25 m	95ASE1210
CS-A1-03-U-50	5-pole M12 cable (axial) 50 m	95A252700
CS-A1-06-U-03	8-pole M12 cable (axial) 3 m	95ASE1220
CS-A1-06-U-05	8-pole M12 cable (axial) 5 m	95ASE1230
CS-A1-06-U-10	8-pole M12 cable (axial) 10 m	95ASE1240
CS-A1-06-U-15	8-pole M12 cable (axial) 15 m	95ASE1250
CS-A1-06-U-25	8-pole M12 cable (axial) 25 m	95ASE1260
CS-A1-06-U-50	8-pole M12 cable (axial) 50 m	95A252710

14.8. Safety relay

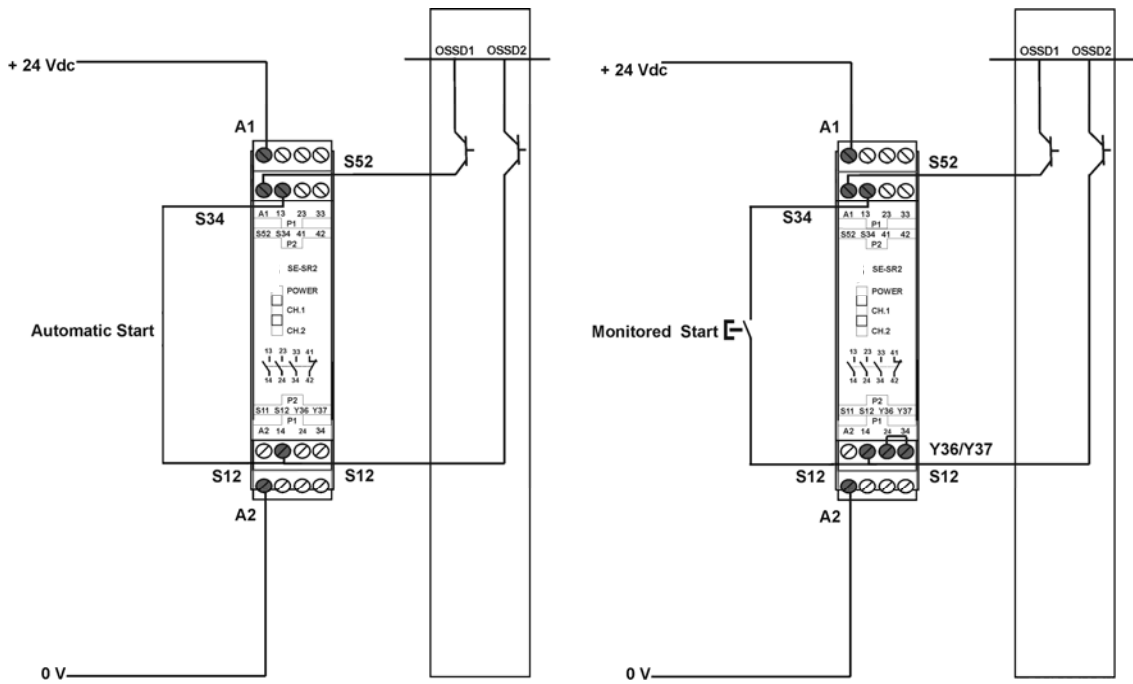

The drawing shows the connection between the safety light curtain and the Type 4 safety relay of the SE-SR2 series functioning in the automatic Start mode (left side) and manual Start with monitoring (right side).

MODEL	DESCRIPTION	CODE
SE-SR2	Type 4 safety relay - 3 NO 1NC	95ACC6170

## 15. GLOSSARY

**ACTIVE OPTOELECTRONIC PROTECTIVE DEVICE (AOPD):** its detection function is achieved thanks to the use of optoelectronic receivers and emitters detecting the optical beams interruptions inside the device caused by an opaque object present inside the specified detecting area.

An active optoelectronic protective device (AOPD) can operate both in emitter-receiver mode and in retro-reflective light curtains.

**BLOCK CONDITION (=BREAK):** status of the light curtain taking place when a suitably-sized opaque object (see DETECTING CAPACITY) interrupts one or several light curtain beams.

Under these conditions, OSSD1 and OSS2 light curtain outputs are simultaneously switched OFF within the device response time.

**CONTROLLED MACHINE:** machine having the potentially-dangerous points protected by the light curtain or by another safety system.

**CROSSING HAZARD:** situation under which an operator crossing the area controlled by the safety device and this latter stops and keeps the machine stopped until the hazard is eliminated, and then enters the dangerous area. Now the safety device could not be able to prevent or avoid an unexpected restart of the machine with the operator still present inside the dangerous area.

**EMITTER:** unit emitting infrared beams, consisting of a set of optically-synchronised LEDs. The emitting unit, combined with the receiving unit (installed in the opposite position), generates an optical "curtain", i.e. the detecting area.

**DANGEROUS AREA:** area representing an immediate or imminent physical hazard for the operator working inside it or who could get in contact with it.

**DETECTING CAPACITY (= RESOLUTION):** limit of the parameter of the sensor function specified by the supplier, that will enable the electrosensitive protective equipment (ESPE). In case of an active optoelectronic protective device (AOPD), with resolution we mean the minimum dimension, which an opaque object must have in order to interrupt at least one of the beams that constitute the sensitive area.

**ELECTROSENSITIVE PROTECTIVE EQUIPMENT (ESPE):** assembly of devices and/or components working together to activate the protective disabling function or to detect the presence of something and including at least: a sensor, command/control devices and output signal switching devices.

**FINAL SWITCHING DEVICE (FSD):** part of the control system connected to machine safety and breaking the circuit towards machine primary command element (MPCE) when the output signal switching device (OSSD) reaches the inactive condition.

**OUTPUT SIGNAL SWITCHING DEVICE (OSSD):** part of the electrosensitive protective equipment (ESPE) connected to machine control system that, when the sensor is triggered during standard operating mode, is switched to the inactive status.

**MACHINE OPERATOR:** qualified person authorised for machine use.

**MACHINE PRIMARY COMMAND ELEMENT (MPCE):** electrically-powered element having the direct control of machine regular operation so as to be the last element, in order of time, to operate when the machine has to be enabled or blocked.

**MIN. INSTALLATION DISTANCE:** min. distance necessary to allow machine dangerous moving parts to completely stop before the operator can reach the nearest dangerous point. This distance shall be measured from the middle point of the detecting area to the nearest dangerous point. The factors affecting min. installation distance value are: machine stop time, safety system overall response time, barrier resolution.

**N.O.:** normally opened

**N.C.:** normally closed

**OFF STATUS:** status when the output circuit is interrupted and does not allow current stream.

**PROTECTED AREA:** area where a specified test object is detected by the ESPE.

**PROTECTIVE DEVICE:** device having the function to protect the operator against possible risks of injury due to the contact with machine potentially-dangerous parts.

**QUALIFIED OPERATOR:** a person who holds a professional training certificate or having a wide knowledge and experience and who is acknowledged as qualified to install and/or use of the product and to carry out periodical test procedures.

**RECEIVER:** unit receiving infrared beams, consisting of a set of optically-synchronised phototransistors. The receiving unit, combined with the emitting unit (installed in the opposite position), generates an optical "curtain", i.e. the detecting area.

**RESTART INTERLOCK (= RESTART):** device preventing machine automatic restart after sensor activation during a dangerous phase of machine operating cycle, after a change of machine operating mode, and after a variation in machine start control devices.

**RISK:** probability of occurrence of an injury and severity of the injury itself.

**SAFETY LIGHT CURTAIN:** it is an active optoelectronic protective device (AOPD) including an integrated system consisting of one or several emitting elements and one or several receiving elements forming a detection area with a detecting capacity specified by the supplier.

**START INTERLOCK (= START):** device preventing machine automatic start when the ESPE is powered, or when the power supply is cut and then restored.

**WORKING POINT:** machine position where the material or semifinished product is worked.

