

DC Square-body Fuses Microswitches & metric Studs Microswitches for other square-body Protistor®

- REMOTE SIGNALING SYSTEMS FOR FITTING ON
FERRAZ SHAWMUT FUSES EQUIPED WITH MICROSWITCH SUPPORT:
All square-body sizes AC 44 / 8X / 9X / 12X / 17X / 20X / 30X
and DC 7X / 12X / 17X / 30X / 60X
- PERMANENT INDICATION OF FUSE STATE:
 - CONDUCTIVE
 - BLOWN
- MANUAL RESETTING
- STANDARD AND LOW ELECTRICAL LEVEL WITH DIFFERENT INSULATION LEVELS
- VAPOR AND WATER TIGHT TYPE FOR USE IN CORROSIVE ATMOSPHERE



Main Characteristics

Type	Designation	AC or DC Insulation voltage rating Ui (V)	AC voltage withstand test (*)	Impulse voltage test Uimp1,2/50 µs (* *)	Positive operating min. voltage /min. current	Current rating	Interrupting rating						
							Current	Non-inductive circuit			Inductive circuit; L/R = 25ms		
								30V	110V	250V	30V	110V	250V
Standard	MC3E 1-5N	1250V	15 kV	20 kV	20 V	5 A	50/60 Hz	10 A	10 A	7 A			6 A
	MCR3E 1-5N	2200	20 kV	30 kV	50 mA		DC	5 A	0.5 A			1,6 A	0,3 A
Low level	MC3E 1-5NBS	1250 V	15 kV	20 kV	10 V 10 mA	3 A	50/60 Hz	3 A	3 A	3 A	2 A	1 A	1 A
	MCR3E 1-5NBS							2200 V	20 kV (1)	30 kV	DC	3 A	0.5 A
	MCR3E 1-9NBS	6000 V	23 kV (2)	40 kV			3 A		0.5 A				
	MC2R3E 1-5NBS		24 kV (1)										
Watertight IP 50	MC3E 1-5NET	1250 V	11 kV	16 kV	10 V 10 mA	3 A	50 Hz	3 A	3 A		1 A	1 A	
	MCR3E 1-5NET	2200 V	20 kV (1)	30 kV				DC	0.5 A			0,2 A	
	MC2R3E 1-5NET	6000 V	24 kV (2)	40 kV									

Catalog Numbering system: MC3E 1-5 single pole microswitch - MC3E 1-9 double pole microswitch - MCR, MC2R reinforced insulation microswitch.

* Between power circuit and microswitch terminals as per IEC 60 and 694 and NFC 64010 (50/60 Hz 1 min duration in dry air).

** Between power circuit and microswitch terminals Uimp: impulse voltage according to IEC 947-1.

*** Between power circuit and microswitch terminals

(1) fitting sizes 44 - 70 - 71 - 72 - 73 - 83 - 84 fuses.

(2) fitting sizes 91 - 92 - 93 - 94 - 120 - 121 - 122 - 123 - 124 fuses.

(3) fitting sizes 171 - 172 - 173 - 174 - 200 - 203 - 300 - 302 - 600 - 602 fuses.

Protistor DC fuses

DC Square-body Fuses Microswitches & metric Studs Microswitches for other square-body Protistor®

Remote signaling with 1250 V AC/DC insulation voltage

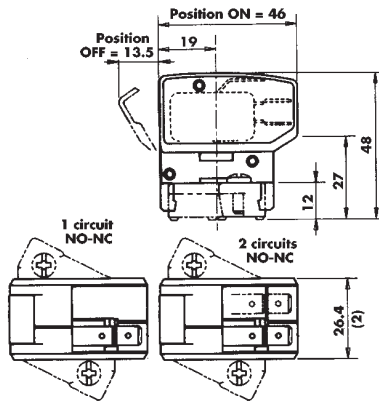

Quantity of NO-NC separated circuits	Contact	Designation	Ref. Number	Weight (g)	Pack. (1)	Catalog Number
1	standard	MC3E 1-5N	D310020	39.5	3	MC3E1-5N
1	low level	MC3E 1-5NBS	E310021	39.5	3	MC3E1-5NBS
2	low level	MC3E 1-9NBS	F310022	45.7	3	MC3E1-9NBS
1	watertight	MC3E 1-5NET	L310027	40.2	3	MC3E1-5N ETANCHE

Remote signaling with insulation voltage up to 2200 V AC/DC

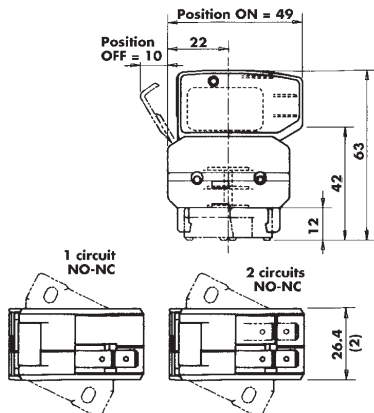

Quantity of NO-NC separated circuits	Contact	Designation	Ref. Number	Weight (g)	Pack. (1)	Catalog Number
1	standard	MCR3E 1-5N	G310023	51.7	1	MCR3E1-5N
1	low level	MCR3E 1-5NBS	P310030	51.7	1	MCR3E1-5NBS
2	low level	MCR3E 1-9NBS	H310024	58.0	1	MCR3E1-9NBS
1	watertight	MCR3E 1-5NET	O310031	52.5	1	MCR3E1-5N ETANCHE

Remote signaling with insulation voltage up to 6000 V AC/DC

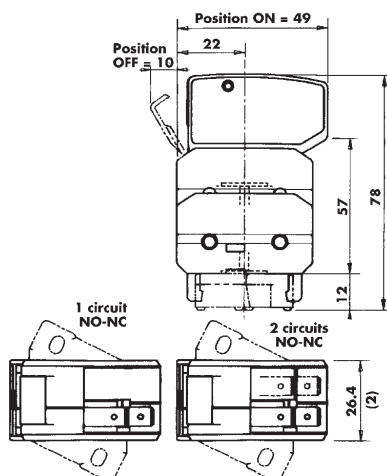

Quantity of NO-NC separated circuits	Contact	Designation	Ref. Number	Weight (g)	Pack. (1)	Catalog Number
1	low level	MC2R3E 1-5NBS	J310025	64.0	1	MC2R3E1-5NBS
1	watertight	MC2R3E 1-5NET	N310029	64.8	1	MC2R3E1-5NET
2	low level	MC2R3E 1-9NBS	K310026	70.3	1	MC2R3E1-9NBS

Electrical diagram of each microswitch circuit

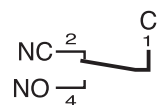

Non-blown fuse
Microswitch ON

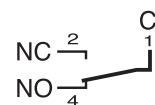

Blown fuse
Microswitch OFF

All of these signalling systems are hand resettable and fitted with silver-plated 3-terminal microswitch C, NO and NC.

The C terminal is on the top and connection is made via 6.35 mm clips except for watertight models whose clips are 4.8 mm wide.

NOTE (2): The 26.4 dimension is the same with 1 or 2 separated circuits NO-NC.

Tests with sine vibrations carried out at ambient with scanning of the three main holder axes.

Spectrum: 1st segment (2 to 16 Hz) constant trip $x = 5$ mm peak.

2nd segment (16 to 250 Hz) constant acceleration $g = 5$ g peak.

Exponential scanning speed : 1 octave per minute.

Duration: 2 hours per axis.