

Xenon Strobe Beacons Series R

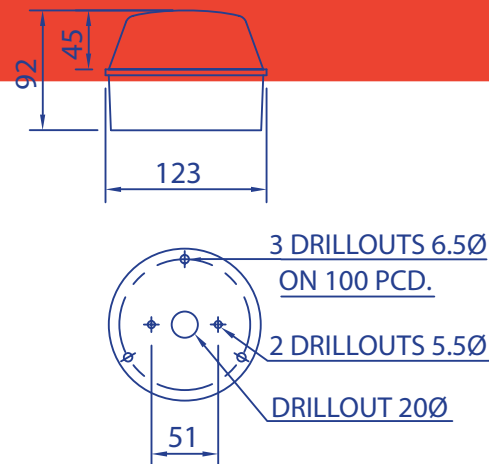

Compact xenon strobe visual warning device featuring ABS base and polycarbonate dome lens. Bases available in White (standard) or Black whilst lenses are available in Red, Amber, Green, Blue or Clear.

2.5 Joule models available for use with a 12-24Vdc, 115Vac or 230Vac supply.

Primarily a uni-directional forward projecting signal with some off-axis visibility.

	XFR/DC/12-24/SH/2.5J	XFR/AC/115/SH/2.5J	XFR/AC/230/SH/2.5J
Supply Voltage	12-24Vdc	115Vac	230Vac
Minimum Supply Voltage	10.2Vdc	97Vac	195Vac
Maximum Supply Voltage	27.6Vdc	132Vac	264Vac
Average Current Draw	146mA	70mA	41mA
Peak Operating Current	452mA	1.4A	354mA
Nominal power consumption	3.5W	3.9W	3.8W
Flash Rate	60fpm 1Hz		
Luminous Intensity	Red	5Cd	
	Amber	20Cd	
	Green	7Cd	
	Blue	7Cd	
	Clear	43Cd	
Angle of max rated brilliance	On axis with front face		
Recommended fuse rating	External - 500mA TD		
IEC protection class	IP65		
Operating Temperature Range	-20 to +55 Degrees C		