

SGLG□, SGLF□, SGLT□

# Sigma linear motors

## Direct drive linear servo motors for faster machine cycles

- Direct control of the motors using XtraDrive and Sigma-II drives
- Improved machine performance
- Easy of operation & high reliability
- Designed for high force density in compact packages
- Exhibit exceptional force linearity even at near peak force regions
- Extremely energy efficient, due to its optimized magnetic circuitry design and high-density windings
- Can reach speeds as high as 5 meters per second.
- Coreless and iron core types available

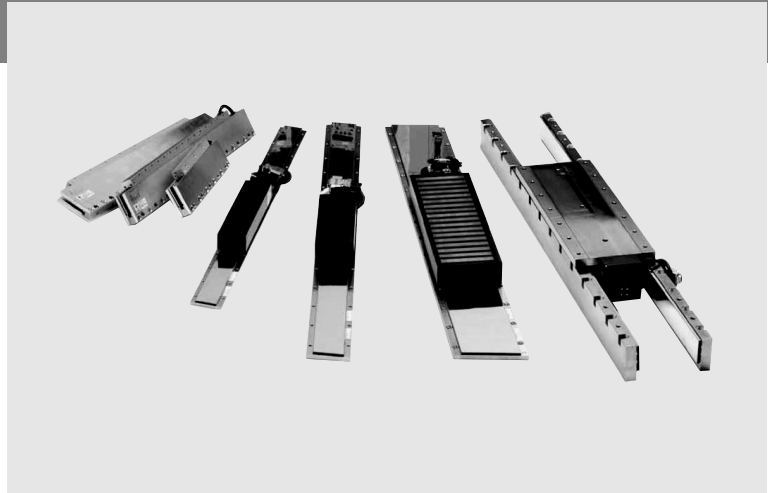

## Ratings

- 230 VAC Single-phase 12.5 to 560 N (1200 N Peak)
- 400 VAC Three-phase 80 to 2250 N (7500 N Peak)

## System configuration

(Refer to servo drive chapter)

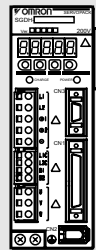

Servo Drive with option boards for flexible system configuration

**Sigma-II Servo Drive**

Drive options

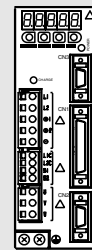



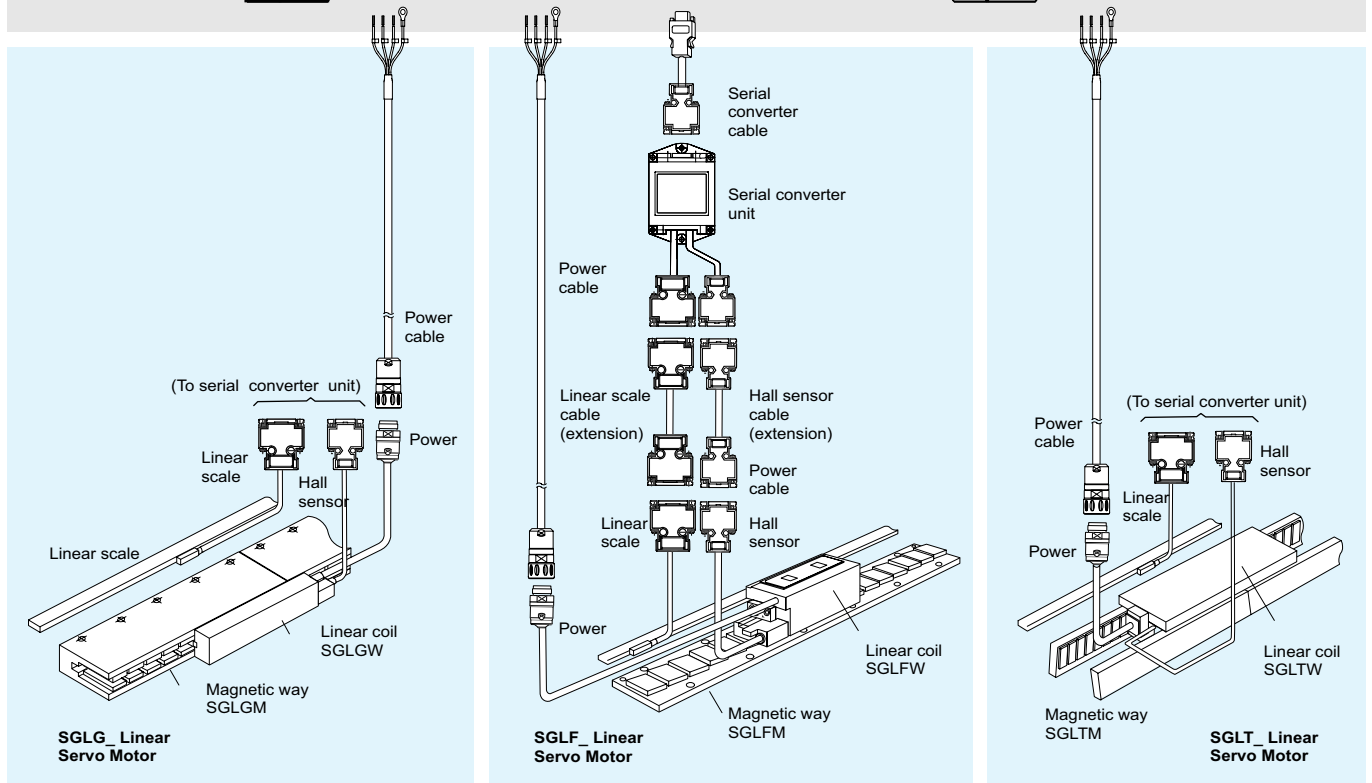

Intelligent Servo Drive

**XtraDrive**



Servo Motor / Servo Drive Combination

Sigma series linear servo motor					Serial converter		Servo drive				
Type	Voltage	Rated force	Peak force	Model	JZDP-□008-[code]		Sigma-II series		XtraDrive		
					code for Rev A, B	code for Rev C	230 V (1-phase)	400 V (3-phase)	230 V (1-phase)	400 V (3-phase)	
SGLGW coreless standard-force magnetic ways 	230 V	12.5 N	40 N	30A050 [B / C]	158	250	SGDH-A5AE-OY	-	XD-P5-MN01	-	
		25 N	80 N	30A080 [B / C]	156	251	SGDH-01AE-OY	-	XD-01-MN01	-	
		47 N	140 N	40A140 [B / C]	001	252	SGDH-01AE-OY	-	XD-01-MN01	-	
		70 N	220 N	60A140 [B / C]	004	258	SGDH-02AE-OY	-	XD-02-MN01	-	
		93 N	280 N	40A253 [B / C]	002	253	SGDH-02AE-OY	-	XD-02-MN01	-	
		140 N	420 N	40A365 [B / C]	003	254	SGDH-04AE-OY	-	XD-04-MN01	-	
		140 N	440 N	60A253 [B / C]	005	259	SGDH-04AE-OY	-	XD-04-MN01	-	
		210 N	660 N	60A365 [B / C]	006	260	SGDH-08AE-S-OY	-	XD-08-MN	-	
		325 N	1300 N	90A200 [A / C]	101	264	SGDH-15AE-S-OY	-	XD-15-MN	-	
SGLGW coreless high-force magnetic ways 	230 V	57 N	230 N	40A140 [B / C]	059	255	SGDH-02AE-OY	-	XD-02-MN01	-	
		114 N	460 N	40A253 [B / C]	060	256	SGDH-04AE-OY	-	XD-04-MN01	-	
		171 N	690 N	40A365 [B / C]	061	257	SGDH-08AE-S-OY	-	XD-08-MN	-	
		85 N	360 N	60A140 [B / C]	062	261	SGDH-02AE-OY	-	XD-02-MN01	-	
		170 N	720 N	60A253 [B / C]	063	262	SGDH-08AE-S-OY	-	XD-08-MN	-	
		255 N	1080 N	60A365 [B / C]	047	263	SGDH-15AE-S-OY	-	XD-15-MN	-	
Type	Voltage	Rated force	Peak force	Model	code		230 V (1-phase)	400 V (3-phase)	230 V (1-phase)	400 V (3-phase)	
SGLFW linear motors 	230 V	25 N	86 N	20A090A	017		SGDH-02AE-OY	-	XD-02-MN01		
		40 N	125 N	20A120A	018		SGDH-02AE-OY	-	XD-02-MN01		
		80 N	220 N	35A120A	019		SGDH-02AE-OY	-	XD-02-MN01		
		160 N	440 N	35A230A	020		SGDH-08AE-S-OY	-	XD-08-MN01		
		280 N	600 N	50A200B	181		SGDH-08AE-S-OY	-	XD-08-MN		
		560 N	1200 N	50A380B	182		SGDH-15AE-S-OY	-	XD-15-MN		
		560 N	1200 N	1ZA200B	183		SGDH-15AE-S-OY	-	XD-15-MN		
		400 V	80 N	220 N	35D120A	211		-	SGDH-05DE-OY	-	XD-05-TN
			160 N	440 N	35D230A	212		-	SGDH-05DE-OY	-	XD-05-TN
	280 N		600 N	50D200B	189		-	SGDH-10DE-OY	-	XD-10-TN	
	560 N		1200 N	50D380B	190		-	SGDH-15DE-OY	-	XD-15-TN	
	560 N		1200 N	1ZD200B	191		-	SGDH-15DE-OY	-	XD-15-TN	
	1120 N		2400 N	1ZD380B	192		-	SGDH-30DE-OY	-	XD-30-TN	
	SGLTW linear motors 	400 V	1500 N	3600 N	1ED380B	333		-	SGDH-20DE-OY	-	XD-20-TN
			2250 N	5400 N	1ED560B	334		-	SGDH-30DE-OY	-	XD-30-TN
300 N			600 N	35D170H	193		-	SGDH-10DE-OY	-	XD-10-TN	
600 N			1200 N	35D320H	194		-	SGDH-20DE-OY	-	XD-20-TN	
450 N			900 N	50D170H	195		-	SGDH-10DE-OY	-	XD-10-TN	
900 N			1800 N	50D320H	196		-	SGDH-20DE-OY	-	XD-20-TN	
670 N			2600 N	40D400B	197		-	SGDH-30DE-OY	-	XD-30-TN	
1000 N			4000 N	40D600B	198		-	SGDH-50DE-OY	-	XD-50-TN	
1300 N			5000 N	80D400B	199		-	SGDH-50DE-OY	-	XD-50-TN	
2000 N	7500 N	80D600B	200		-	SGDH-75DE-OY	-	-			

Motor coil

SGL F W - 35 D 120 A P D

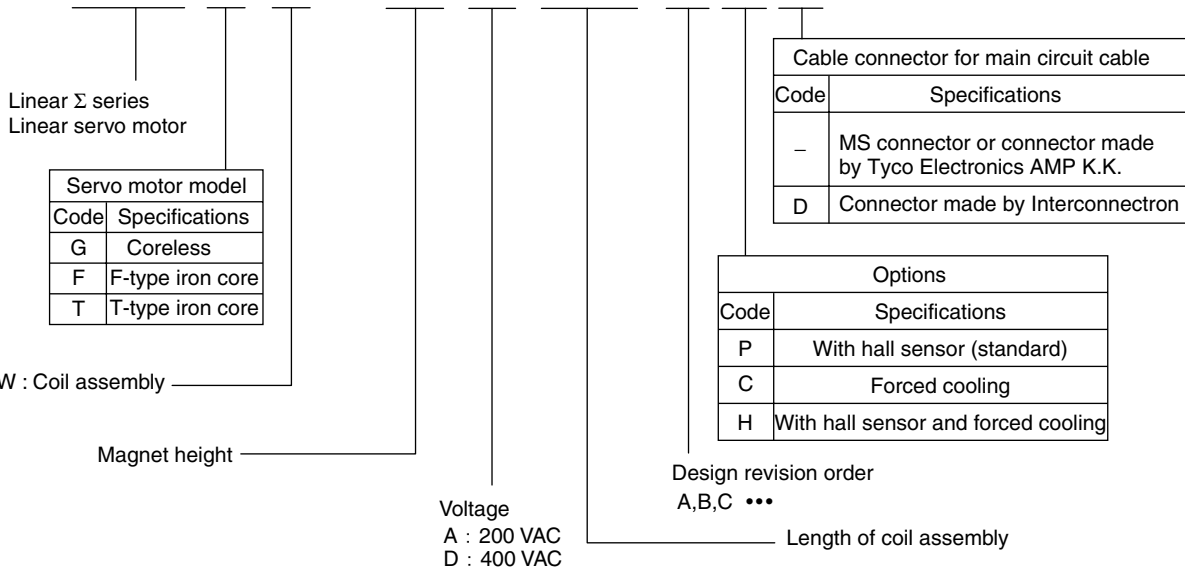

Magnetic way

# SGL F M – 35 324 A C

Linear  $\Sigma$  series  
Linear servo motor

Model	
Code	Specifications
G	Coreless
F	F-type iron core
T	T-type iron core

M : Magnetic way

Magnet width

Length of magnetic way

Design revision order  
A,B,C ...

Options		
Code	Specifications	Remarks
C	With magnet cover	For iron-core types - SGLFM - SGLTM
-Y	With base and magnet cover	For SGLTM type
	Mounting type 1	For SGLGM type
-M	Mounting type 1 & high thrust force	
T-	Mounting type 2	
T-M	Mounting type 2 & high thrust force	

Serial converter unit

# JZDP – D008 – 001

Design revision order  
A,B,C ...

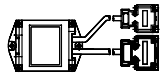
Serial converter unit model			
Symbol	Appearance	Applicable linear scale	Hall sensor
A008 D008		Made by Renishaw or (Heidenhain *)	Yes

Note: \* When using a linear scale made by Heidenhain an extension cable is required

Applicable linear servo motor							
	Servo motor model		Model		Symbol		
SGLGW- (coreless)	30A050B	158	30A050C	250	SGLTW- (Iron core, T-type)	20A170A	011
	30A080B	156	30A080C	251		20A320A	012
	40A140B	001	40A140C	252		20A460A	013
	40A253B	002	40A253C	253		35A170A	014
	40A365B	003	40A365C	254		35A320A	015
	60A140B	004	60A140C	258		35A460A	016
	60A253B	005	60A253C	259		35A170H	105
	60A365B	006	60A365C	260		35A320H	106
	90A200A	101	90A200C	264		50A170H	108
	90A370A	102	90A370C	265		50A320H	109
	90A535A	103	90A535C	266		40A400B	185
	40A140B	059	40A140C	255		40A600B	186
	40A253B	060	40A253C	256		80A400B	187
40A365B	061	40A365C	257	80A600B	188		
60A140B	062	60A140C	261	35D170H	193		
60A253B	063	60A253C	262	35D320H	194		
60A365B	047	60A365C	263	50D170H	195		
SGLGW- + SGLGM- -M (coreless)	20A090A	017			50D320H	196	
	20A120A	018			40D400B	197	
	35A120A	019			40D600B	198	
	35A230A	020			80D400B	199	
	50A200B	181			80D600B	200	
	50A380B	182					
	1ZA200B	183					
	1ZA380B	184					
	35D120A	211					
	35D230A	212					
	50D200B	189					
	50D380B	190					
	1ZD200B	191					
	1ZD380B	192					
1ED380B	333						
1ED560B	334						
SGLFW- (Iron core, F-type)							

Servo motor specifications

Coreless SGLGW/SGLGM - (with standard-force magnetic ways)

Voltage		230 V									
Linear servo motor model SGLGW-		30A			40A			60A			90A
		050C	080C	140C	253C	365C	140C	253C	365C	200C	
Rated force*	N	12.5	25	47	93	140	70	140	210	325	
Rated current*	Arms	0,51	0,79	0,8	1,6	2,4	1,16	2,2	3,3	4,4	
Instantaneous peak force*	N	40	80	140	280	420	220	440	660	1300	
Instantaneous peak current*	Arms	1.62	2.53	2.4	4.9	7.3	3.5	7.0	10.5	17.6	
Coil assembly weight	kg	0.14	0.19	0.40	0.66	0.93	0.48	0.82	1.16	2.2	
Force constant	N / Arms	26.4	33.9	61.5	61.5	61.5	66.6	66.6	66.6	78	
BEMF constant	V / (m / s)	8.8	11.3	20.5	20.5	20.5	22.2	22.2	22.2	26.0	
Motor constant	N / $\sqrt{W}$	3.7	5.6	7.8	11.0	13.5	11.1	15.7	19.2	26.0	
Electrical time constant	ms	0.2	0.4	0.4	0.4	0.4	0.5	0.5	0.5	1.4	
Mechanical time constant	ms	7.30	4.78	5.59	4.96	4.77	3.41	3.08	2.98	3.18	
Thermal resistance (with heat sink)	K / W	5,19	3,11	1,67	0,87	0,58	1,56	0,77	0,51	0,39	
Thermal resistance (without heat sink)	K / W	-	-	3,02	1,80	1,23	2,59	1,48	1,15	1,09	
Magnetic attraction	N	0	0	0	0	0	0	0	0	0	
Heat sink size	mm	200 x 300 x 12			300 x 400 x 12	400 x 500 x 12	200 x 300 x 12	300 x 400 x 12	400 x 500 x 12	800 x 900 x 12	
Basic specifications	Time rating	Continuous									
	Insulation class	Class B									
	Ambient temperature	0 to +40 °C									
	Ambient humidity	20 to 80% (non-condensing)									
	Insulation resistance	500 VDC, 10 MΩ min.									
	Excitation	Permanent magnet									
	Dielectric strength	1500 VAC for 1 minute									
	Protection methods	Self-cooled, air-cooling									
	Allowable winding temperature	130 °C									

- Note:** 1. The items marked with an \* and "force and speed characteristics" are the values at a motor winding temperature of 100 °C during operation in combination with a servo drive. The others are at 20 °C (68°F).  
 2. The above specifications show the values under the cooling condition when a heat sink (aluminium board) listed in the following table is mounted on the coil assembly.

Force-speed characteristics - (with standard-force magnetic ways)

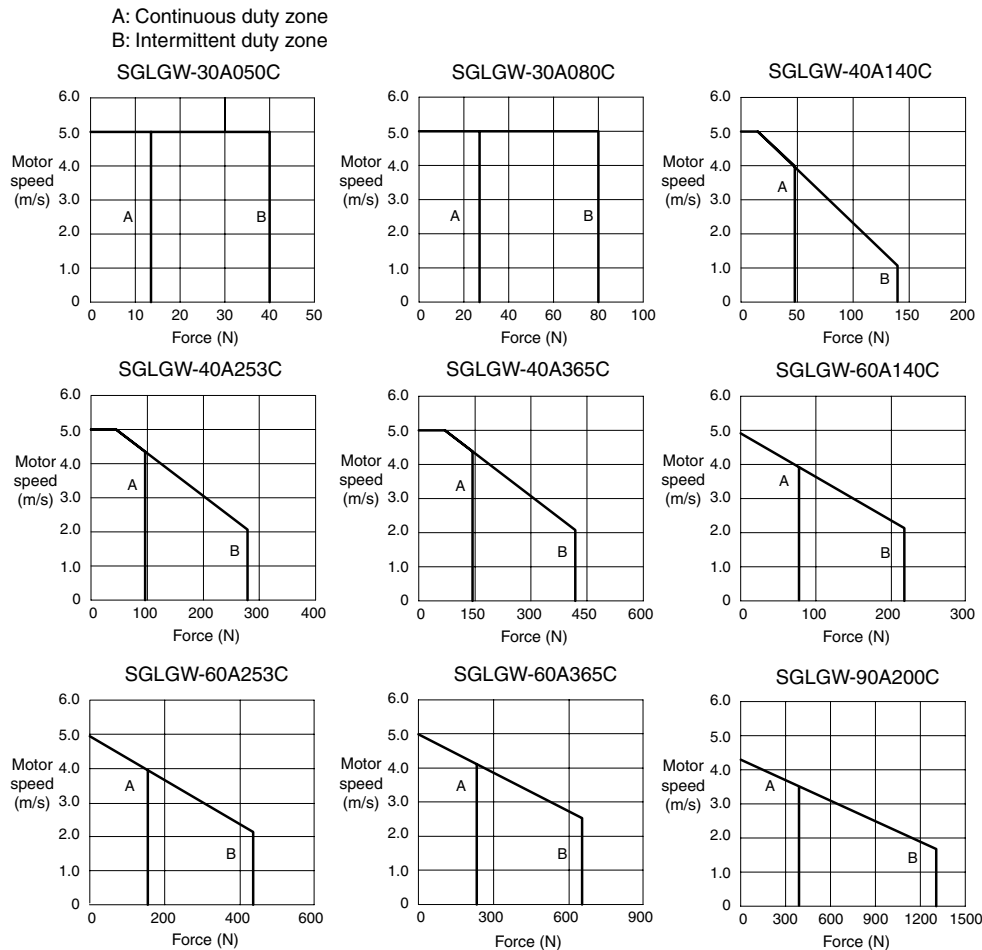

Coreless SGLGW/SGLGM - (with high-force magnetic ways)

Voltage		230 V					
Linear servo motor model SGLGW-		40A			60A		
		140C	253C	365C	140C	253C	365C
Rated force*	N	57	114	171	85	170	255
Rated current*	Arms	0.8	1.6	2.4	1.2	2.2	3.3
Instantaneous peak force*	N	230	460	690	360	720	1080
Instantaneous peak current*	Arms	3.2	6.5	9.7	5.0	10.0	14.9
Coil assembly weight	kg	0.40	0.66	0.93	0.48	0.82	1.16
Force constant	N / Arms	76.0	76.0	76.0	77.4	77.4	77.4
BEMF constant	V / (m / s)	25.3	25.3	25.3	25.8	25.8	25.8
Motor constant	N / $\sqrt{w}$	9.6	13.6	16.7	12.9	18.2	22.3
Electrical time constant	ms	0.4	0.4	0.4	0.5	0.5	0.5
Mechanical time constant	ms	3.69	3.24	3.12	2.52	2.29	2.21
Thermal resistance (with heat sink)	K / W	1.67	0.87	0.58	1.56	0.77	0.51
Thermal resistance (without heat sink)	K / W	3.02	1.80	1.23	2.59	1.48	1.15
Magnetic attraction	N	0	0	0	0	0	0
Heat sink size	mm	200 x 300 x 12	300 x 400 x 12	400 x 500 x 12	200 x 300 x 12	300 x 400 x 12	400 x 500 x 12
Basic specifications	Time rating	Continuous					
	Insulation class	Class B					
	Ambient temperature	0 to +40 °C					
	Ambient humidity	20 to 80% (non-condensing)					
	Insulation resistance	500 VDC, 10 MΩ min.					
	Excitation	Permanent magnet					
	Dielectric strength	1500 VAC for 1 minute					
	Protection methods	Self-cooled, air-cooling					
Allowable winding temperature	130 °C						

- Note:** 1. The items marked with an \* and “force and speed characteristics” are the values at a motor winding temperature of 100 °C during operation in combination with a servo drive. The others are at 20 °C (68°F).  
 2. The above specifications show the values under the cooling condition when a heat sink (aluminium board) listed in the following table is mounted on the coil assembly.

Force-speed characteristics - (with high-force magnetic ways)

A: Continuous duty zone  
 B: Intermittent duty zone

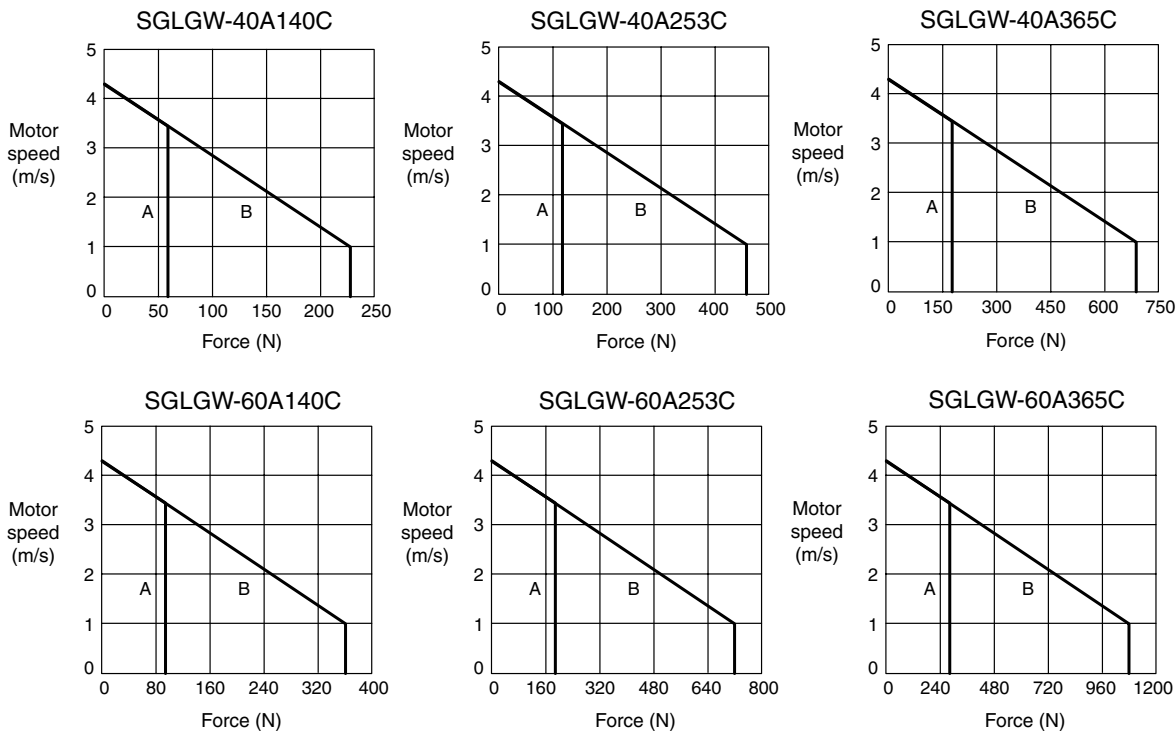

Iron-core SGLFW/SGLFM (200 V)

Voltage Linear servo motor model SGLFW-		230 V						
		20A		35A		50A		1ZA
		090A	120A	120A	230A	200B	380B	200B
Rated force*	N	25	40	80	160	280	560	560
Rated current*	Arms	0.7	0.8	1.4	2.8	5.0	10.0	8.7
Instantaneous peak force*	N	86	125	220	440	600	1200	1200
Instantaneous peak current*	Arms	3.0	2.9	4.4	8.8	12.4	25.0	21.6
Coil assembly weight	kg	0.7	0.9	1.3	2.3	3.5	6.9	6.4
Force constant	N / Arms	36.0	54.0	62.4	62.4	60.2	60.2	69.0
BEMF constant	V / (m / s)	12.0	18.0	20.8	20.8	20.1	20.1	23.0
Motor constant	N / $\sqrt{W}$	7.9	9.8	14.4	20.4	34.3	48.5	52.4
Electrical time constant	ms	3.2	3.3	3.6	3.6	15.9	15.8	18.3
Mechanical time constant	ms	11.0	9.3	6.2	5.5	3.0	2.9	2.3
Thermal resistance (with heat sink)	K / W	4.35	3.19	1.57	0.96	0.82	0.32	0.6
Thermal resistance (without heat sink)	K / W	7.69	5.02	4.10	1.94	1.48	0.74	0.92
Magnetic attraction	N	314	462	809	1586	1650	3260	3300
Heat sink size	mm	125 x 125 x 13		254 x 254 x 25			400 x 500 x 40	254 x 254 x 25
Basic specifications	Time rating	Continuous						
	Insulation class	Class B						
	Ambient temperature	0 to +40 °C						
	Ambient humidity	20 to 80% (non-condensing)						
	Insulation resistance	500 VDC, 10 MΩ min.						
	Excitation	Permanent magnet						
	Dielectric strength	1500 VAC for 1 minute						
	Protection methods	Self-cooled						
Allowable winding temperature	130 °C							

- Note:** 1. The items marked with an \* and “force and speed characteristics” are the values at a motor winding temperature of 100 °C during operation in combination with a servo drive. The others are at 20 °C (68°F).  
 2. The above specifications show the values under the cooling condition when a heat sink (aluminium board) listed in the following table is mounted on the coil assembly.

Force-speed characteristics (200 V)

- A: Continuous duty zone  
 B: Intermittent duty zone

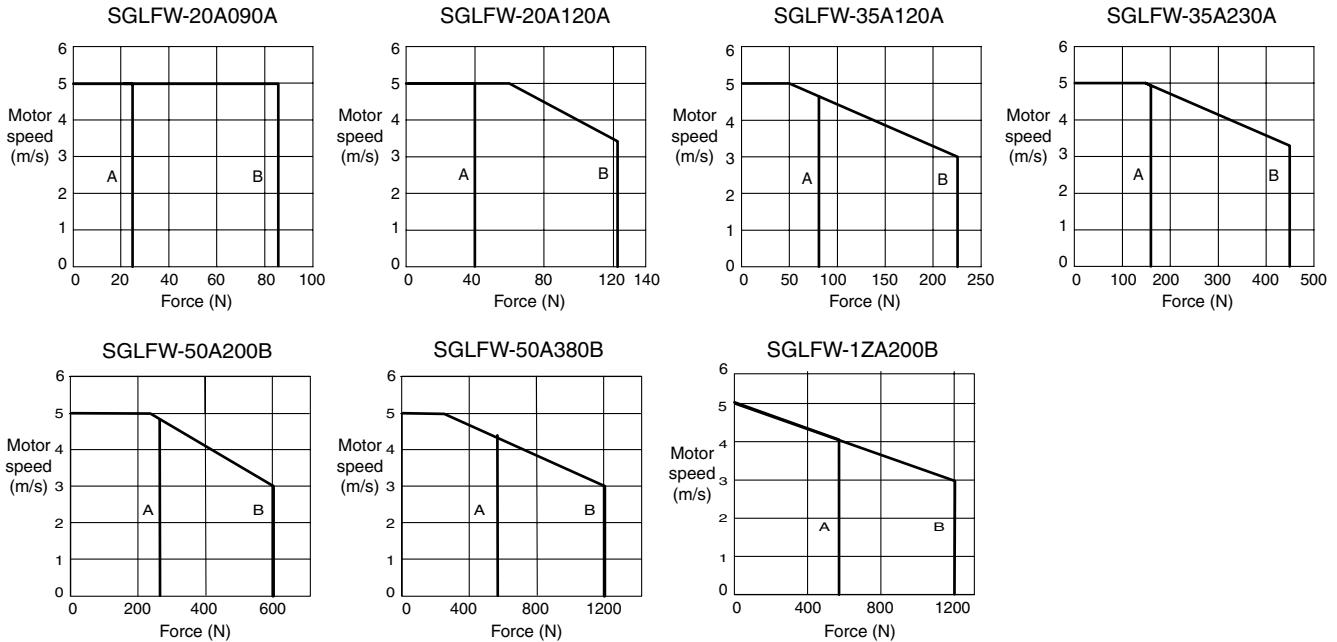

Iron-core SGLFW/SGLFM (400 V)

Voltage		400 V							
Linear servo motor model SGLFW-		35D		50D		1ZD		1ED	
		120A	230A	200B	380B	200B	380B	380B	560B
Rated force*	N	80	160	280	560	560	1120	1500	2250
Rated current*	Arms	0.7	1.4	2.3	4.5	4.9	9.8	6.4	9.6
Instantaneous peak force*	N	220	440	600	1200	1200	2400	3600	5400
Instantaneous peak current*	Arms	2.3	4.6	5.6	11.0	12.3	24.6	18.1	27.2
Coil assembly weight	kg	1.3	2.3	3.5	6.9	6.4	11.5	22	33
Force constant	N / Arms	120.2	120.2	134.7	134.7	122.6	122.6	250	250
BEMF constant	V / (m / s)	40.1	40.1	44.9	44.9	40.9	40.9	83.2	83.2
Motor constant	N / $\sqrt{W}$	13.8	19.5	33.4	47.2	51.0	72.1	95.4	117
Electrical time constant	ms	3.5	3.5	15.0	15.0	17.4	17.2	19.7	19.6
Mechanical time constant	ms	5.5	5.5	3.2	3.2	2.5	2.2	1.8	1.8
Thermal resistance (with heat sink)	K / W	1.57	0.96	0.82	0.32	0.6	0.28	0.21	0.13
Thermal resistance (without heat sink)	K / W	4.1	1.94	1.48	0.74	0.92	0.55	0.50	0.35
Magnetic attraction	N	810	1590	1650	3260	3300	6520	9780	14600
Heat sink size	mm	254 x 254 x 25			400 x 500 x 40	254 x 254 x 25	400 x 500 x 40	609 x 762 x 50	762 x 1270 x 64
Basic specifications	Time rating	Continuous							
	Insulation class	Class B							
	Ambient temperature	0 to +40 °C							
	Ambient humidity	20 to 80% (non-condensing)							
	Insulation resistance	500 VDC, 10 M $\Omega$ min.							
	Excitation	Permanent magnet							
	Dielectric strength	1500 VAC for 1 minute							
	Protection methods	Self-cooled							
	Allowable winding temperature	130 °C							

- Note:** 1. The items marked with an \* and “force and speed characteristics” are the values at a motor winding temperature of 100 °C during operation in combination with a servo drive. The others are at 20 °C (68°F).  
 2. The above specifications show the values under the cooling condition when a heat sink (aluminium board) listed in the following table is mounted on the coil assembly.

Force-speed characteristics (400 V)

A: Continuous duty zone  
 B: Intermittent duty zone

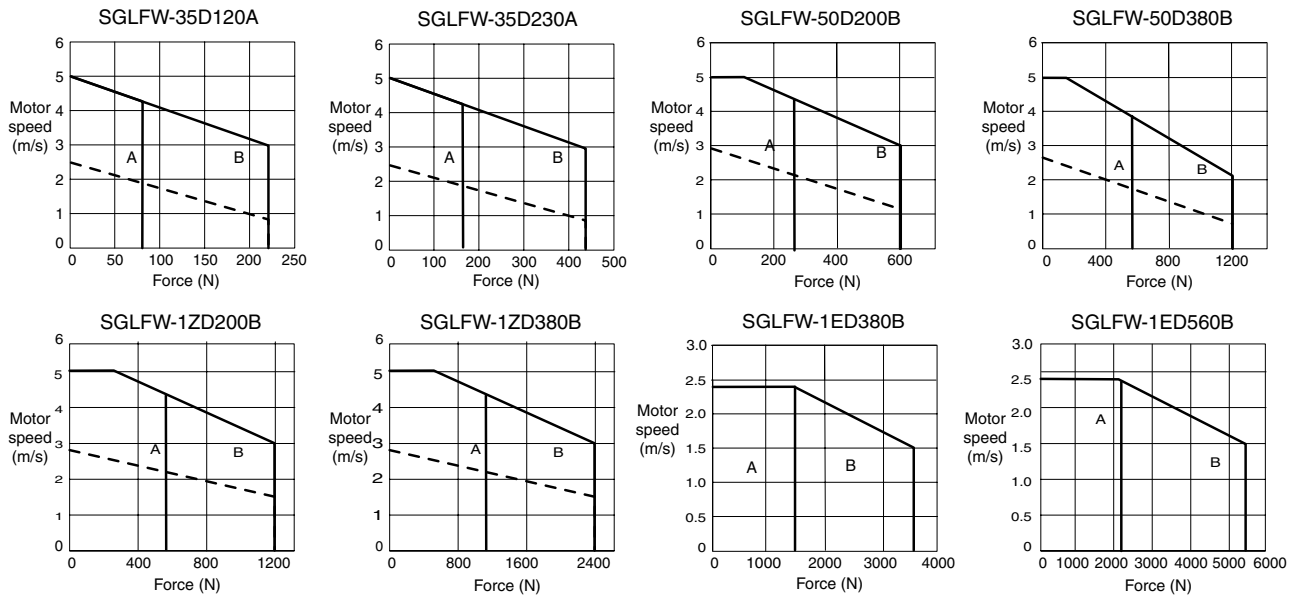

**Note:** The dotted line indicates characteristics when the linear servo motor for 400 VAC is used with an input power supply for 200 VAC. In this case, the serial converter should be changed. Contact your OMRON Yaskawa representatives.

Iron-core SGLTW/SGLTM (400 V)

Voltage		400 V							
Linear servo motor model SGLTW-		35D		50D		40D		80D	
		170H	320H	170H	320H	400B	600B	400B	600B
Rated force*	N	300	600	450	900	670	1000	1300	2000
Rated current*	Arms	3.2	6.5	3.2	6.3	3.7	5.5	7.2	11.1
Instantaneous peak force*	N	600	1200	900	1800	2600	4000	5000	7500
Instantaneous peak current*	Arms	7.5	15.1	7.3	14.6	20.7	30.6	37.6	56.4
Coil assembly weight	kg	4.7	8.8	6	11	15	23	25	36
Force constant	N / Arms	99.6	99.6	153.3	153.3	196.1	196.1	194.4	194.4
BEMF constant	V / (m / s)	33.2	33.2	51.1	51.1	65.4	65.4	64.8	64.8
Motor constant	N / $\sqrt{W}$	36.3	51.4	48.9	69.1	59.6	73	85.9	105.2
Electrical time constant	ms	14.3	14.3	15.6	15.6	14.4	14.4	15.4	15.4
Mechanical time constant	ms	3.5	3.5	2.5	2.5	4.2	4.2	3.2	3.2
Thermal resistance (with heat sink)	K / W	0.76	0.4	0.61	0.3	0.24	0.2	0.22	0.18
Thermal resistance (without heat sink)	K / W	1.26	0.83	0.97	0.8	0.57	0.4	0.47	0.33
Magnetic attraction* <sup>1</sup>	N	0	0	0	0	0	0	0	0
Magnetic attraction* <sup>2</sup>	N	1400	2780	2000	3980	3950	5890	7650	11400
Heat sink size	mm	400 x 500 x 40				609 x 762 x 50			
Basic specifications	Time rating	Continuous							
	Insulation class	Class B							
	Ambient temperature	0 to +40 °C							
	Ambient humidity	20 to 80% (non-condensing)							
	Insulation resistance	500 VDC, 10 MW min.							
	Excitation	Permanent magnet							
	Dielectric strength	1500 VAC for 1 minute							
	Protection methods	Self-cooled							
	Allowable winding temperature	130 °C							

\*1. The unbalanced magnetic gap resulting from the coil assembly installation condition causes a magnetic attraction on the coil assembly.

\*2. The value indicates the magnetic attraction generated on one side of the magnetic way.

**Note: 1.** The items marked with an \* and "force and speed characteristics" are the values at a motor winding temperature of 100 °C during operation in combination with a servo drive. The others are at 20 °C (68 °F).

**2.** The above specifications show the values under the cooling condition when a heat sink (aluminium board) listed in the following table is mounted on the coil assembly.

Force-speed characteristics (400 V)

A: Continuous duty zone  
B: Intermittent duty zone

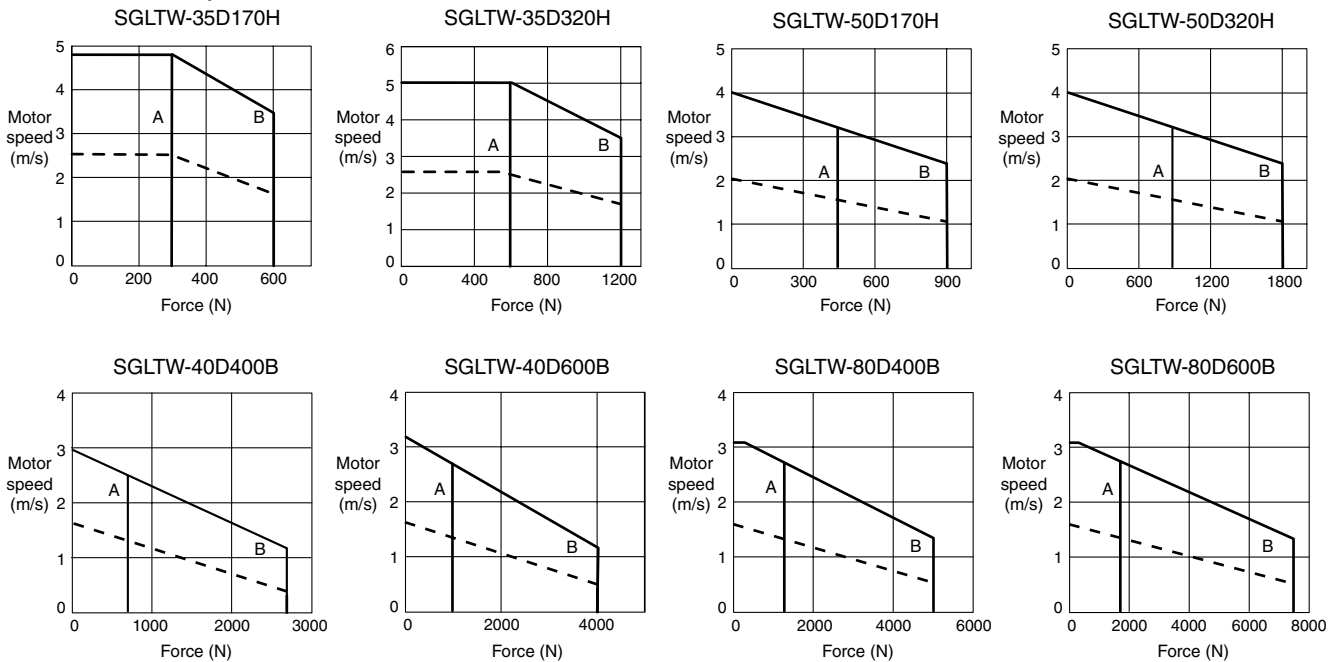

**Note:** The dotted line indicates characteristics when the linear servo motor for 400 VAC is used with an input power supply for 200 VAC. In this case, the serial converter should be changed. Contact your OMRON Yaskawa representatives.



Dimensions

Coreless SGLG□-30

Coil assembly: SGLGW-30A□□□□□□

Coil assembly model SGLGW-	L1	L2	L3	L4	L5	G(Gap)	Approx. weight* kg	
30A050□□□□	50	48	30	20	20	0.85	0.14	*The value indicates the weight of coil assembly with a hall sensor unit.
30A080□□□□	80	72	50	30	25	0.95	0.19	

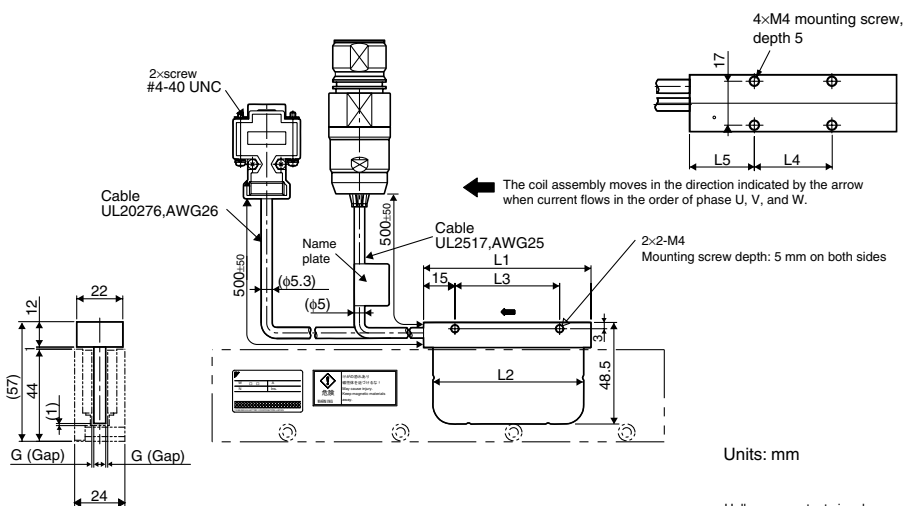

Hall sensor connector specifications

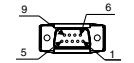

Pin connector type: 17JE-23090-02 (D8C) made by DDK Ltd.

The mating connector  
Socket connector type: 17JE-13090-02 (D8C)  
Stud type: 17L-002C or 17L-002C1

Pin No.	Name
1	+5V (Power supply)
2	Phase U
3	Phase V
4	Phase W
5	0V (Power supply)
6	Not used
7	Not used
8	Not used
9	Not used

Linear servo motor Connector specifications



Extension: SPOC06JMSCN169  
Pin type: 021.423.1020 made by Interconnectron

The mating connector  
Plug type: SPOC06KFSDN169

Pin No.	Name	Lead color
1	Phase U	Red
2	Phase V	White
3	Phase W	Blue
4	Not used	-
5	Not used	-
6	FG	Green/yellow
7	Not used	-

Hall sensor output signals

When the coil assembly moves in the direction indicated by the arrow in the figure, the relationship between the hall sensor output signals Su, Sv, Sw and the inverse power of each motor phase Vu, Vv, Vw becomes as shown in the following figure.

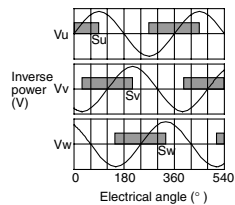

Magnetic way: SGLGM-30□□□□A

Magnetic way model SGLGM-	L1 mm	L2 mm	N	Approx. weight kg
30108A	108	54	2	0.6
30216A	216	162	4	1.1
30432A	432	378	8	2.3

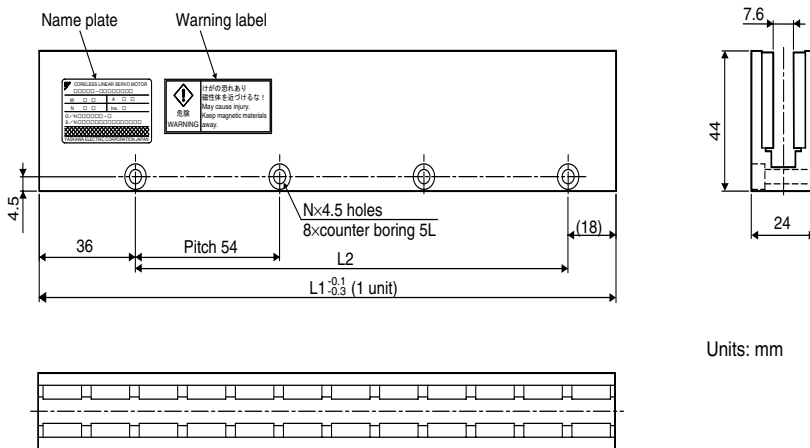

## Coreless SGLG□-40

### Coil assembly: SGLGW-40□□□□□□

Coil assembly model SGLGW-	L1	L2	L3	L4	L5	L6	N1	N2	Approx. weight* kg	
40A140□□□□	140	125	90	30	52.5	45	3	4	0.40	*The value indicates the weight of coil assembly with a hall sensor unit.
40A253□□□□	252.5	237.5	180	37.5	60	135	5	8	0.66	
40A365□□□□	365	350	315	30	52.5	270	8	14	0.93	

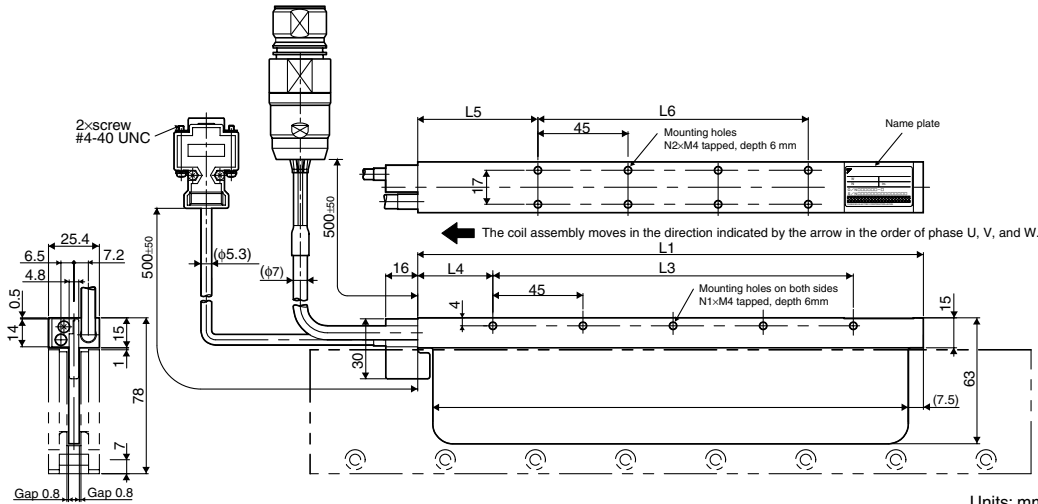

Units: mm

Hall sensor connector specifications

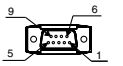

Pin connector type: 17JE-23090-02 (D8C) made by DDK Ltd.

The mating connector

Socket connector type: 17JE-13090-02 (D8C)  
Stud type: 17L-002C or 17L-002C1

Pin No.	Name
1	+5V (Power supply)
2	Phase U
3	Phase V
4	Phase W
5	0V (Power supply)
6	Not used
7	Not used
8	Not used
9	Not used

Linear servo motor connector specifications



Extension: SROC06JM5CN169  
Pin type: 021.423.1020 made by Interconnection

The mating connector  
Plug type: SPOC06KFSDN169

Pin No.	Name	Lead color
1	Phase U	Red
2	Phase V	White
3	Phase W	Blue
4	Not used	-
5	Not used	-
6	FG	Green/yellow
7	Not used	-

Hall sensor output signals

When the coil assembly moves in the direction indicated by the arrow in the figure, the relationship between the hall sensor output signals Su, Sv, Sw and the inverse power of each motor phase Vu, Vv, Vw becomes as shown in the figure below.

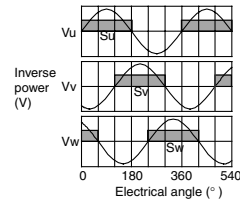

### Standard-force magnetic way: SGLGM-40□□□□C□

Standard-force magnetic way model SGLGM-		L1 mm	L2 mm	N	Approx. weight kg
Mounting type 1	Mounting type 2				
40090C	40090CT	90	45	2	0.8
40225C	40225CT	225	180	5	2.0
40360C	40360CT	360	315	8	3.1
40405C	40405CT	405	360	9	3.5
40450C	40450CT	450	405	10	3.9

### High-force magnetic way: SGLGM-40□□□□C□-M

High-force magnetic way model SGLGM-		L1 mm	L2 mm	N	Approx. weight kg
Mounting type 1	Mounting type 2				
40090C-M	40090CT-M	90	45	2	1.0
40225C-M	40225CT-M	225	180	5	2.6
40360C-M	40360CT-M	360	315	8	4.1
40405C-M	40405CT-M	405	360	9	4.6
40450C-M	40450CT-M	450	405	10	5.1

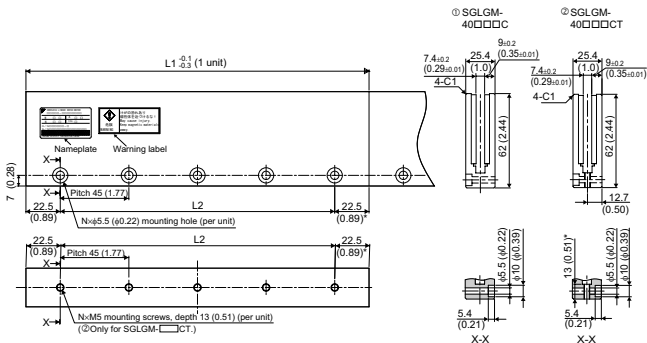

\* Reference length  
Units: mm (in)

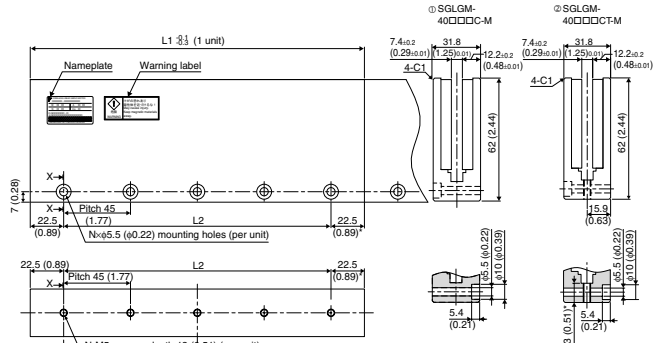

\* Reference length  
Units: mm (in)

**Note:** Mounting dimensions of magnets revision B are equivalent to magnets revision C mounting type 2

Coreless SGLG□-60

Coil assembly: SGLGW-60A□□□□□D

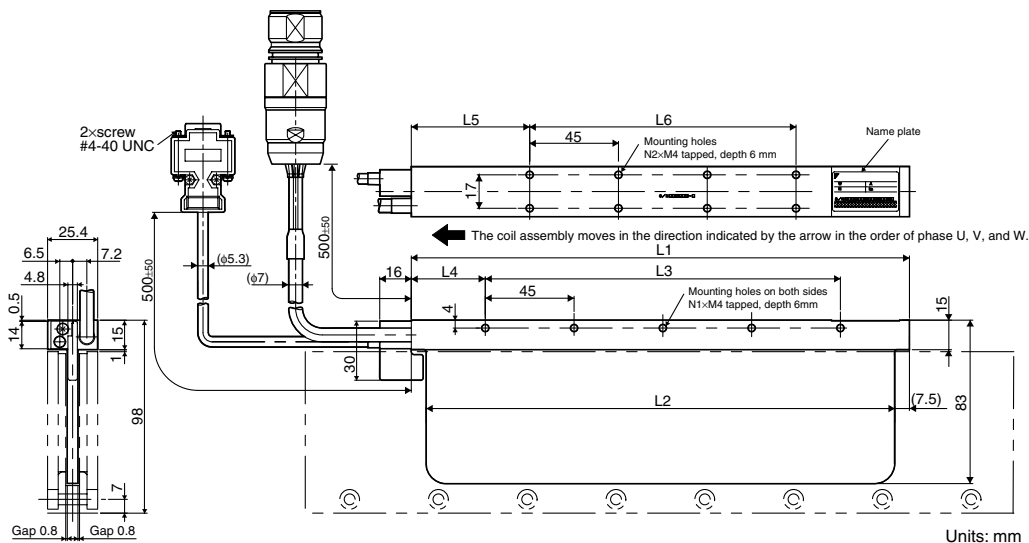

Units: mm

Hall sensor Connector Specifications

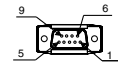

Pin connector type: 17JE-23090-02 (D8C) made by DDK Ltd.

The mating connector  
Socket connector type: 17JE-13090-02 (D8C)  
Stud type: 17L-002C or 17L-002C1

Pin No.	Name
1	+5V (Power supply)
2	Phase U
3	Phase V
4	Phase W
5	0V (Power supply)
6	Not used
7	Not used
8	Not used
9	Not used

Linear servo motor Connector specifications



Extension: SROCC06JMSCN169  
Pin type: 021.423.1020 made by Interconnectron

The mating connector  
Plug type: SPOC06KFSDN169

Pin No.	Name	Lead Color
1	Phase U	Red
2	Phase V	White
3	Phase W	Blue
4	Not used	-
5	Not used	-
6	FG	Green/yellow
7	Not used	-

Hall sensor output signals

When the coil assembly moves in the direction indicated by the arrow in the figure, the relationship between the hall sensor output signals Su, Sv, Sw and the inverse power of each motor phase Vu, Vv, Vw becomes as shown in the figure below.

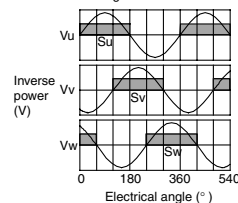

Coil assembly model SGLGW-	L1	L2	L3	L4	L5	L6	N1	N2	Approx. weight <sup>*</sup> kg
60A140□□D	140	125	90	30	52.5	45	3	4	0.48
60A253□□D	252.5	237.5	180	37.5	60	135	5	8	0.82
60A365□□D	365	350	315	30	52.5	270	8	14	1.16

\*The value indicates the weight of coil assembly with a hall sensor unit.

Standard-force magnetic way: SGLGM-60□□□□□

Standard-force magnetic way model SGLGM-		L1 mm	L2 mm	N	Approx. weight kg
Mounting type 1	Mounting type 2				
60090C	60090CT	90	45	2	1.1
60225C	60225CT	225	180	5	2.6
60360C	60360CT	360	315	8	4.1
60405C	60405CT	405	360	9	4.6
60450C	60450CT	450	405	10	5.1

High-force magnetic way: SGLGM-60□□□□□-M

High-force magnetic way model SGLGM-		L1 mm	L2 mm	N	Approx. weight kg
Mounting type 1	Mounting type 2				
60090C-M	60090CT-M	90	45	2	1.3
60225C-M	60225CT-M	225	180	5	3.3
60360C-M	60360CT-M	360	315	8	5.2
60405C-M	60405CT-M	405	360	9	5.9
60450C-M	60450CT-M	450	405	10	6.6

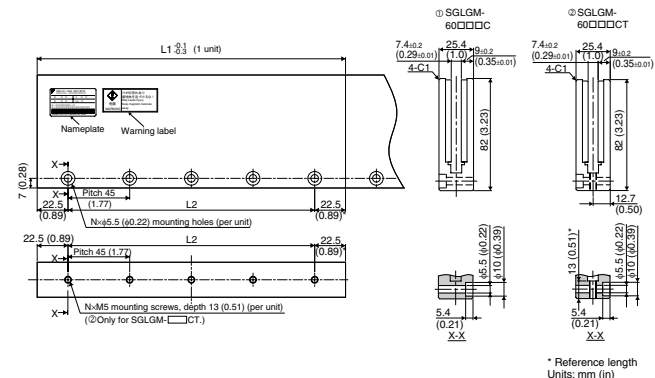

\* Reference length Units: mm (in)

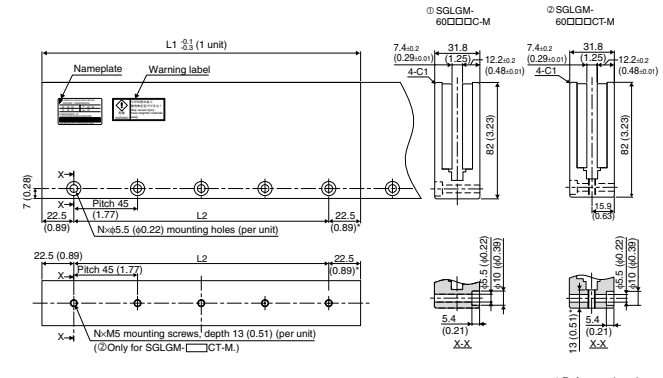

\* Reference length Units: mm (in)

Note: Mounting dimensions of magnets revision B are equivalent to magnets revision C mounting type 2.

Coreless SGLG□-90

Coil assembly: SGLGW-90A200□□D

Coil assembly model SGLGW-	L1	L2	L3	L4	L5	L6	N1	N2	Approx. weight* kg	
90A200□□D	199	189	130	40	60	95	3	4	2.2	*The value indicates the weight of coil assembly with a hall sensor unit.

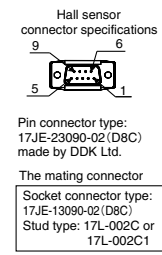
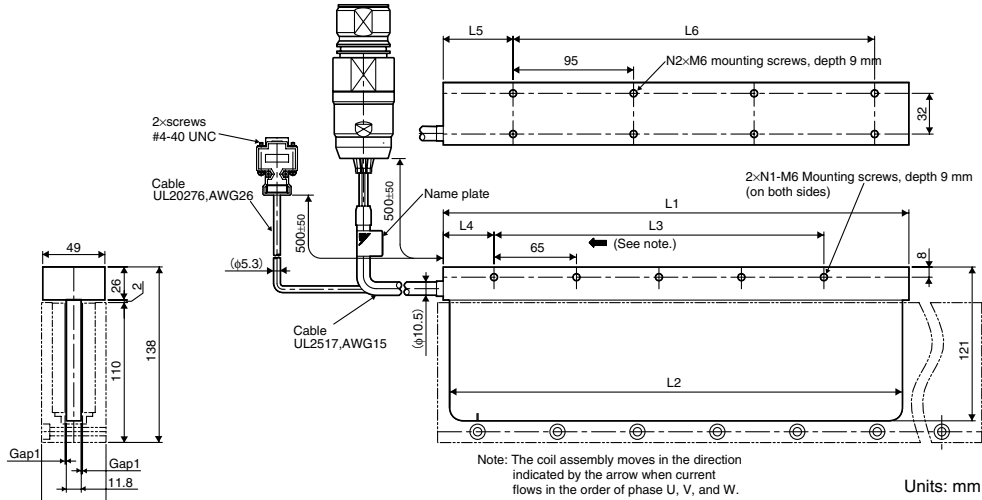

Pin No.	Name
1	+5V (Power supply)
2	Phase U
3	Phase V
4	Phase W
5	0V (Power supply)
6	Not used
7	Not used
8	Not used
9	Not used

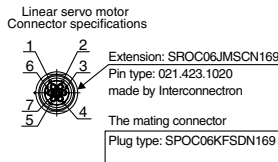

Pin No.	Name	Lead color
1	Phase U	Red
2	Phase V	White
3	Phase W	Blue
4	Not used	-
5	Not used	-
6	FG	Green/yellow
7	Not used	-

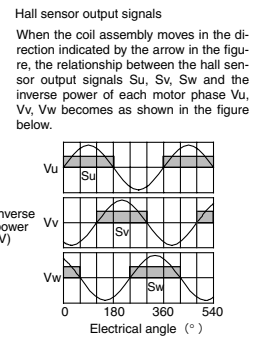

Magnetic way: SGLGM-90□□□A

Magnetic way model SGLGM-	L1 mm	L2 mm	N	Approx. weight kg
90252A	252	189	4	7.3
90504A	504	441	8	14.7

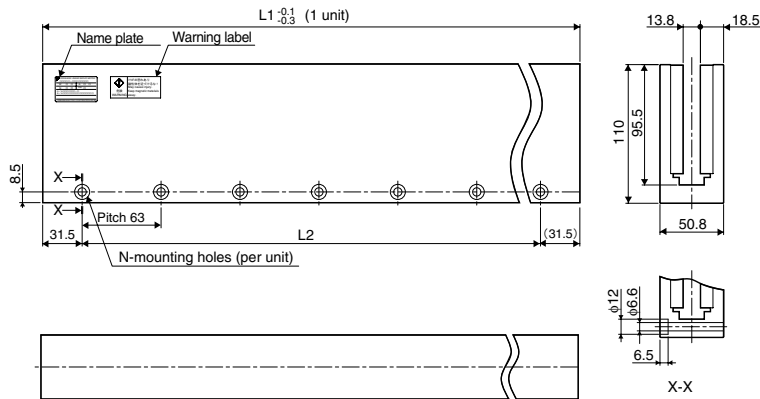

Units: mm

Iron-core SGLF□-20

Coil assembly: SGLFW-20A□□□A□D

Coil assembly model SGLFW-	L1	L2	L3	N	Approx. weight kg
20A090A□	91	36	72	2	0.7
20A120A□	127	72	108	3	0.9

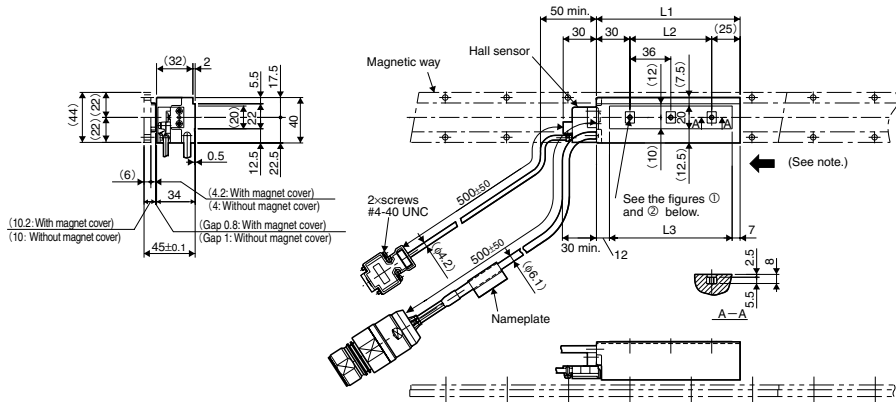

① SGLFW-20A090A□D

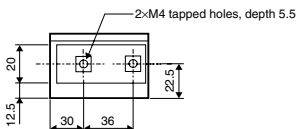

② SGLFW-20A120A□D

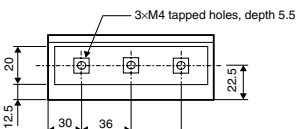

Units: mm

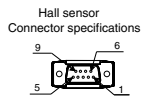

Pin connector type: 17JE-23090-02 (D8C) made by DDK Ltd.

The mating connector  
Socket connector type: 17JE-13090-02 (D8C)  
Stud type: 17L-002C or 17L-002C1

Pin No.	Name
1	+5V (Power supply)
2	Phase U
3	Phase V
4	Phase W
5	0V (Power supply)
6	Not used
7	Not used
8	Not used
9	Not used

Linear servo motor Connector specifications



Extension: SROC06JMSCN169  
Pin type: 021.423.1020  
made by Interconnectron

The mating connector  
Plug type: SPOC06KFSDN169

Pin No.	Name	Lead color
1	Phase U	Red
2	Phase V	White
3	Phase W	Blue
4	Not used	-
5	Not used	-
6	FG	Green/yellow
7	Not used	-

Hall sensor output signals  
When the coil assembly moves in the direction indicated by the arrow in the figure, the relationship between the hall sensor output signals Su, Sv, Sw and the inverse power of each motor phase Vu, Vv, Vw becomes as shown in the figure below.

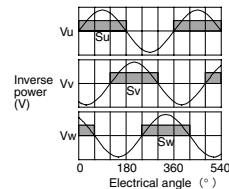

Magnetic way: SGLFM-20□□□A□

Magnetic way model SGLFM-	L1 <sup>-0.1</sup> <sub>-0.3</sub>	L2	(L3)	N	Approx. weight kg
20324A□	324	270 (54 × 5)	(331.6)	6	0.9
20540A□	540	486 (54 × 9)	(547.6)	10	1.4
20756A□	756	702 (54 × 13)	(763.6)	14	2

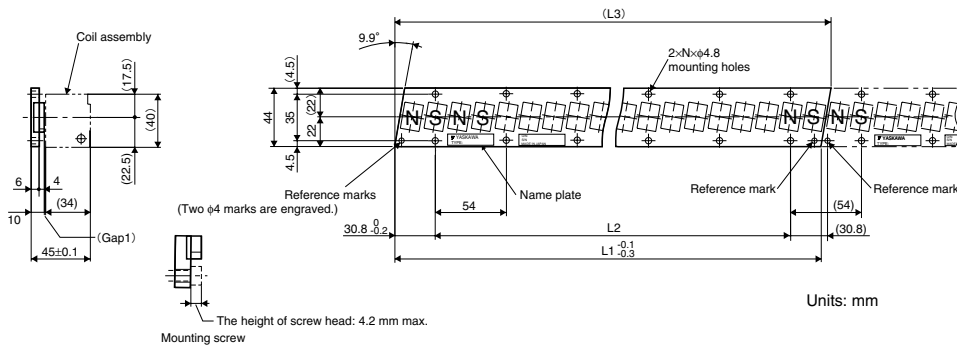

**Note:** 1. Multiple SGLFM-20□□□A magnetic ways can be connected. Connect magnetic ways so that the reference marks match one on the other in the same direction as shown in the figure.

2. The magnetic way may affect pacemakers. Keep a minimum distance of 200 mm from the magnetic way

Iron-core SGLF□-35

Coil assembly: SGLFW-35□□□□A□□

Coil assembly model SGLFW-	L1	L2	L3	N	Approx. weight kg
35□120A□□	127	72	108	6	1.3
35□230A□□	235	180	216	12	2.3

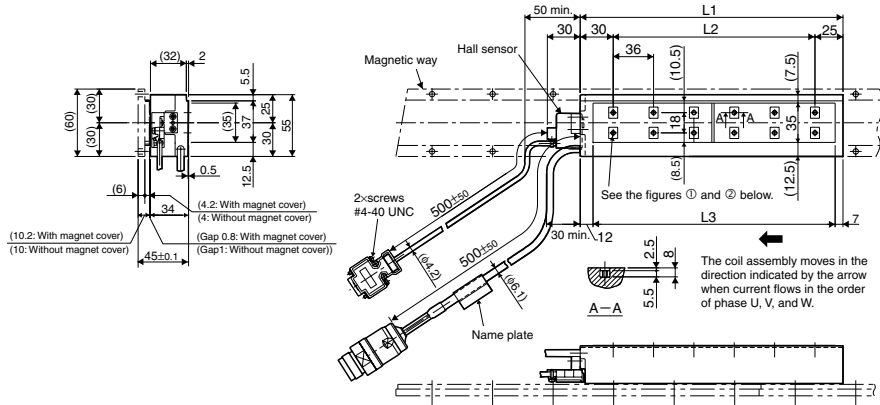

① SGLFW-35□120A□□

② SGLFW-35□230A□□

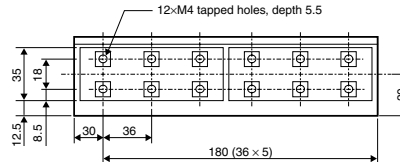
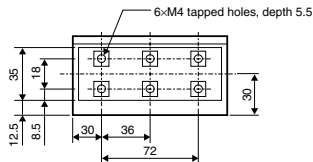

Units: mm

Hall sensor Connector specifications

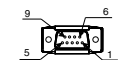

Pin connector type: 7JE-23090-02 (D8C) made by DDK Ltd.

The mating connector Socket connector type: 17JE-13090-02 (D8C) Stud type: 17L-002C or 17L-002C1

Pin No.	Name
1	+5V (Power supply)
2	Phase U
3	Phase V
4	Phase W
5	0V (Power supply)
6	Not used
7	Not used
8	Not used
9	Not used

SGLFW-35A□□□A□□ Linear servo motor 200 V Connector specifications



Extension: SPOC06JMSCN169 Pin type: 021.423.1020 made by Interconnectron

The mating connector Plug type: SPOC06KFSND169

Pin No.	Name
1	Phase U
2	Phase V
3	Phase W
4	Not used
5	Not used
6	FG
7	Not used

SGLFW-35D□□□A□□ Linear servo motor 400 V Connector specifications



Extension: LRRA06AMRPN182 Pin type: 021.279.1020 made by Interconnectron

The mating connector Plug type: LPRA06BFRBN170

Pin No.	Name
1	Phase U
2	Phase V
4	Phase W
5	Not used
6	Not used
Ⓞ	Ground

Hall sensor output signals

When the coil assembly moves in the direction indicated by the arrow in the figure, the relationship between the hall sensor output signals Su, Sv, Sw and the inverse power of each motor phase Vu, Vv, Vw becomes as shown in the figure below.

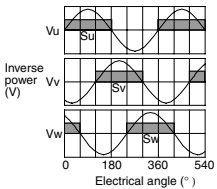

Magnetic way: SGLFM-35□□□□A□□

Magnetic way model SGLFM-	L1 <sup>+0.1</sup> / <sub>-0.3</sub>	L2	(L3)	N	Approx. weight kg
35324A□	324	270 (54 × 5)	(334.4)	6	1.2
35540A□	540	486 (54 × 9)	(550.4)	10	2
35756A□	756	702 (54 × 13)	(766.4)	14	2.9

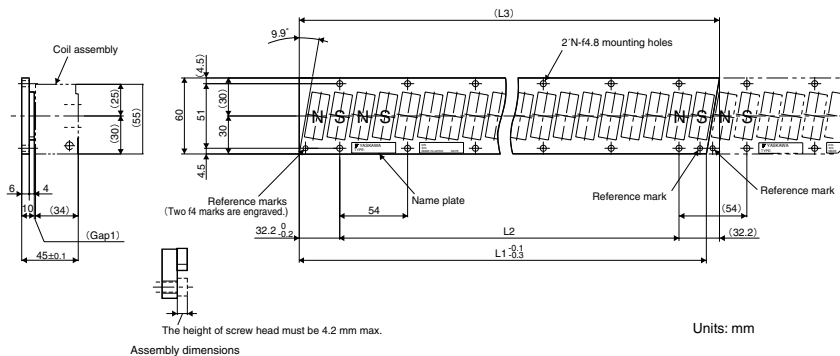

Units: mm

- Note:** 1. Multiple SGLFM-35□□□□A magnetic ways can be connected. Connect magnetic ways so that the reference marks match one on the other in the same direction as shown in the figure.
- 2. The magnetic way may affect pacemakers. Keep a minimum distance of 200 mm from the magnetic way.

Iron-core SGLF□-50

Coil assembly: SGLFW-50□□□□B□D

Coil assembly model SGLFW-	L1	L2	L3	N	Approx. weight kg
50□200B□D	215	120	180	6	3.5
50□380B□D	395	300	360	12	6.9

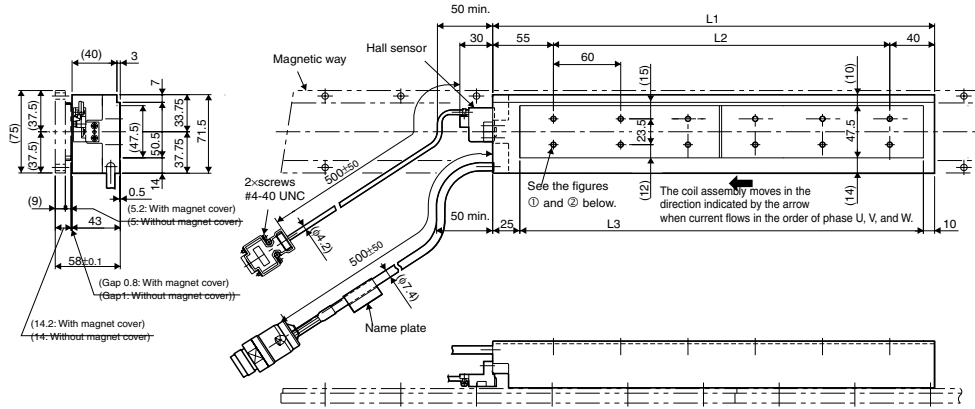

① SGLFW-50□200B□D

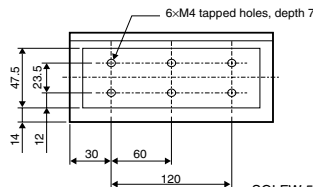

② SGLFW-50□380B□D

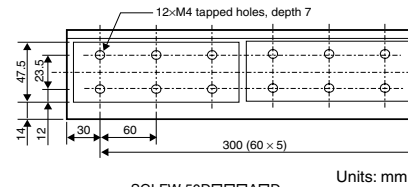

Hall sensor Connector specifications

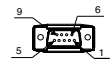

Pin connector type: 7JE-23090-02 (D8C) made by DDK Ltd.

The mating connector Socket connector type: 17JE-13090-02 (D8C) Stud type: 17L-002C or 17L-002C1

Pin No.	Name
1	+SV (Power supply)
2	Phase U
3	Phase V
4	Phase W
5	0V (Power supply)
6	Not used
7	Not used
8	Not used
9	Not used

SGLFW-50A□□□□D Linear servo motor 200 V Connector Specifications



Extension: SROC06JM5CN169 Pin type: 021.423.1020 made by Interconnection

The mating connector Plug type: SPOC06KFSDN169

Pin No.	Name
1	Phase U
2	Phase V
3	Phase W
4	Not used
5	Not used
6	FG
7	Not used

SGLFW-50D□□□□D Linear servo motor 400 V Connector Specifications



Extension: LRRA06AMRPN182 Pin type: 021.279.1020 made by Interconnection

The mating connector Plug type: LPRA06BFRBN170

Pin No.	Name
1	Phase U
2	Phase V
4	Phase W
5	Not used
6	Not used
⊕	Ground

Hall sensor output signals

When the coil assembly moves in the direction indicated by the arrow in the figure, the relationship between the hall sensor output signals Su, Sv, Sw and the inverse power of each motor phase Vu, Vv, Vw becomes as shown in the figure below.

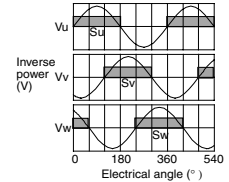

Magnetic way: SGLFM-50□□□□A□

Magnetic way model SGLFM-	L1 -0.1 -0.3	L2	(L3)	N	Approx. weight kg
50135A□	135	67.5 (67.5 × 1)	(146.3)	2	1.0
50405A□	405	337.5 (67.5 × 5)	(416.3)	6	2.8
50675A□	675	607.5 (67.5 × 9)	(686.3)	10	4.6
50945A□	945	877.5 (67.5 × 13)	(956.3)	14	

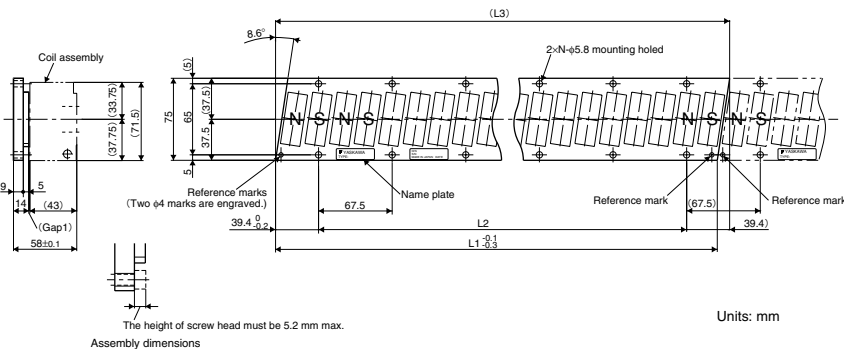

- Note:**
- Multiple SGLFM-50□□□□A magnetic ways can be connected. Connect magnetic ways so that the reference marks match one on the other in the same direction as shown in the figure.
  - The magnetic way may affect pacemakers. Keep a minimum distance of 200 mm from the magnetic way

## Iron-core SGLF□-1Z

### Coil assembly: SGLFW-1Z□□□□B□□

Coil assembly model SGLFW-	L1	L2	L3	N	Approx. weight kg
1Z□200B□□	215	120	180	8	6.4
1ZD380B□□	395	300	360	18	11.5

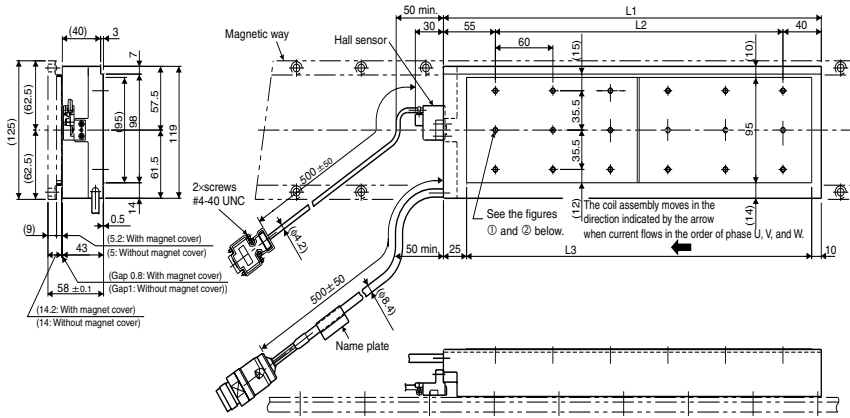

① SGLFW-1Z□200B□□

② SGLFW-1ZD380B□□

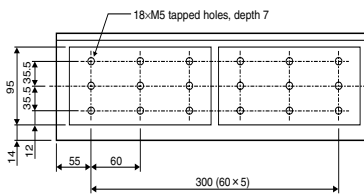
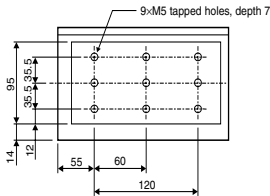

Hall sensor  
Connector specifications

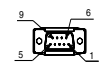

Pin connector type:  
17JE-23090-02 (D8C)  
made by DDK Ltd.

The mating connector

Socket connector type:  
17JE-13090-02 (D8C)  
Stud type: 17L-002C or  
17L-002C1

Pin No.	Name
1	+5V (Power supply)
2	Phase U
3	Phase V
4	Phase W
5	0V (Power supply)
6	Not used
7	Not used
8	Not used
9	Not used

SGLFW-1ZA200A□□  
Linear servo motor 200 V  
Connector specifications



Extension: SPOC06JM5CN169  
Pin type: 021 423 1020  
made by Interconnection

The mating connector  
Plug type: SPOC06KFSDN169

Pin No.	Name
1	Phase U
2	Phase V
3	Phase W
4	Not used
5	Not used
6	FG
7	Not used

SGLFW-1ZD□□□□□□  
Linear servo motor 400 V  
Connector specifications



Extension: LPPRA06AMRPN182  
Pin type: 021 279 1020  
made by Interconnection

The mating connector  
Plug type: LPPRA06BFRBN170

Pin No.	Name
1	Phase U
2	Phase V
4	Phase W
5	Not used
6	Not used
⊕	Ground

Units: mm

Hall sensor output signals

When the coil assembly moves in the direction indicated by the arrow in the figure, the relationship between the hall sensor output signals Su, Sv, Sw and the inverse power of each motor phase Vu, Vv, Vw becomes as shown in the figure below.

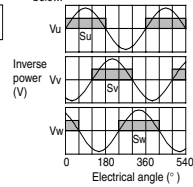

### Magnetic way: SGLFM-1Z□□□□A□

Magnetic way model SGLFM-	L1 -0.1 -0.3	L2	(L3)	N	Approx. weight kg
1Z135A□	135	67.5 (67.5 × 1)	(153.9)	2	1.7
1Z405A□	405	337.5 (67.5 × 5)	(423.9)	6	5
1Z675A□	675	607.5 (67.5 × 9)	(693.9)	10	8.3
1Z945A□	945	877.5 (67.5 × 13)	(963.9)	14	12

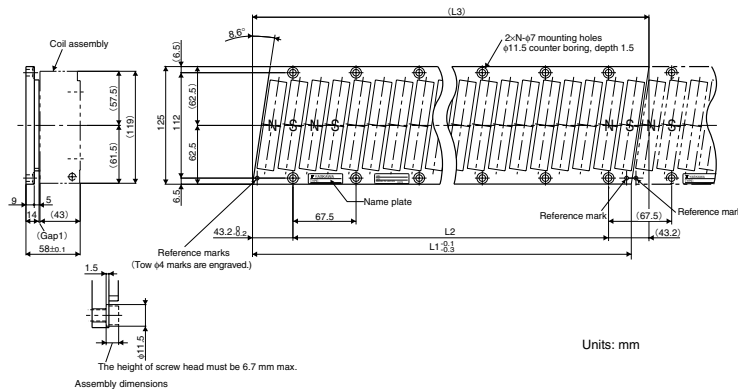

Units: mm

**Note:** 1. Multiple SGLFM-1Z□□□□A magnetic ways can be connected. Connect magnetic ways so that the reference marks match one on the other in the same direction as shown in the figure.

2. The magnetic way may affect pacemakers. Keep a minimum distance of 200 mm from the magnetic way



Iron-core SGLF□-1E

Coil assembly: SGLFW-1ED□□□B□

Coil assembly model SGLFW-	L1	L2	L3	N	P	Approx. weight kg
1ED380B□	395	120	-	12	0.3	22
1ED560B□	605	135	135	18	0.5	33

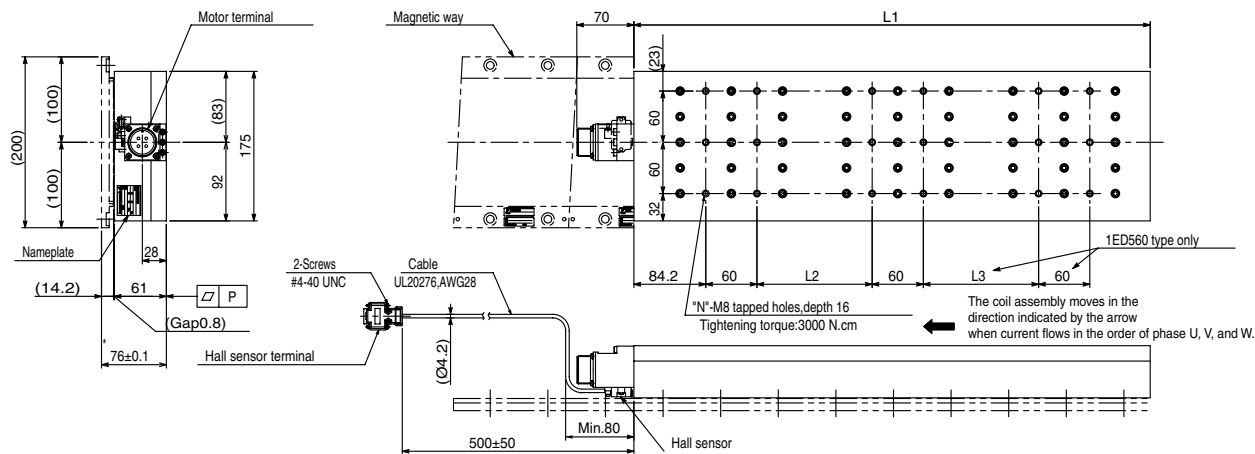

Units: mm

Hall sensor Connector specifications



Pin connector type: 17JE-23090-02 (D8C) made by DDK Ltd.

The mating connector

Socket connector type: 17JE-13090-02 (D8C)  
Stud type: 17L-002C or 17L-002C1

Pin No.	Name
1	+5V (Power supply)
2	Phase U
3	Phase V
4	Phase W
5	0V (Power supply)
6	Not used
7	Not used
8	Not used
9	Not used

Linear servo motor Connector Specifications



Receptacle type: MS3102A-22-22P made by DDK Ltd.

The mating connector

L-shaped plug type: MS3108E22-22S

Pin No.	Name
A	Phase U
B	Phase V
C	Phase W
D	Ground

Hall sensor output signals

When the coil assembly moves in the direction indicated by the arrow in the figure, the relationship between the hall sensor output signals Su, Sv, Sw and the inverse power of each motor phase Vu, Vv, Vw becomes as shown in the figure below.

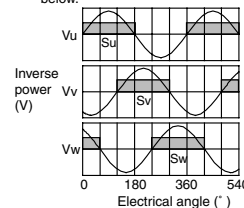

Magnetic way: SGLFM-1E135A□

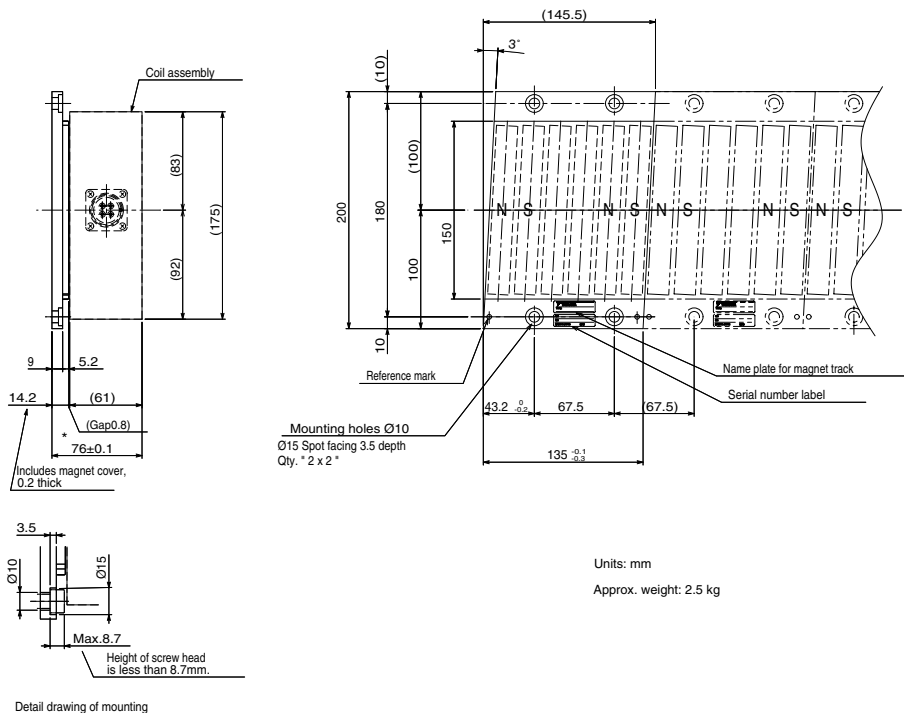

Units: mm  
Approx. weight: 2.5 kg

- Note:**
- Multiple SGLFM-1E□□□A magnetic ways can be connected. Connect magnetic ways so that the reference marks match one on the other in the same direction as shown in the figure.
  - The magnetic way may affect pacemakers. Keep a minimum distance of 200 mm from the magnetic way

Iron-core SGLT□-35

Coil assembly: SGLTW-35D□□□H□D

Coil assembly model SGLTW-	L1	L2	(L3)	N	Approx. weight kg
35D320H□D	315	288 (48 × 6)	(17)	14	8.8

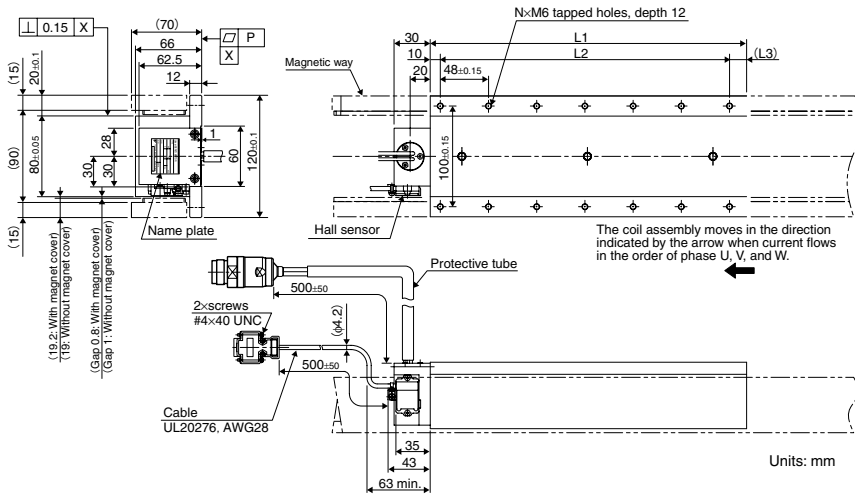

Wiring specification of hall sensor cable

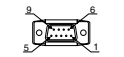

Pin connector type: 17JE-23090-02 (D8C) made by DDK Ltd.

The mating connector  
Socket connector type: 17JE-13090-02 (D8C)  
Stud type: 17L-002C or 17L-002C1

Pin No.	Name
1	+5VDC
2	Phase U
3	Phase V
4	Phase W
5	0V
6	Not used
7	Not used
8	Not used
9	Not used

Linear servo motor Connector specifications

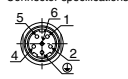

Extension: LPRRA06AMRPN182  
Pin type: 021.279.1020 made by Interconnector

The mating connector  
Plug type: LPRRA06BFRBN170

Hall sensor output signals

When the coil assembly moves in the direction indicated by the arrow in the figure, the relationship between the hall sensor output signals Su, Sv, Sw and the inverse power of each motor phase Vu, Vv, Vw becomes as shown in the figure below

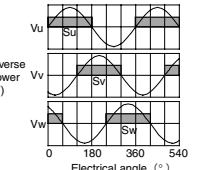

Magnetic way: SGLTM-35□□□H

Magnetic way model SGLTM-	L1 <sup>-0.1</sup> / <sub>-0.3</sub>	L2	N	Approx. weight kg
35324H	324	270 (54 × 5)	6	4.8
35540H	540	486 (54 × 9)	10	8
35756H	756	702 (54 × 13)	14	11

- Note:**
- Two magnetic ways for both ends of coil assembly make one set. Spacers are mounted on magnetic ways for safety during transportation. Do not remove the spacers until the coil assembly is mounted on a machine.
  - The magnetic way may affect pacemakers. Keep a minimum distance of 200 mm from the magnetic way.
  - Two magnetic ways in a set can be connected to each other.
  - The dimensions marked with an \* are the dimensions between the magnetic ways. Be sure to follow exactly the dimensions specified in the figure above. Mount magnetic ways as shown in Assembly Dimensions. The values with an \* are the dimensions at preshipment.
  - Use socket headed screws of strength class 10.9 minimum for magnetic way mounting screws. Do not use stainless steel screws.

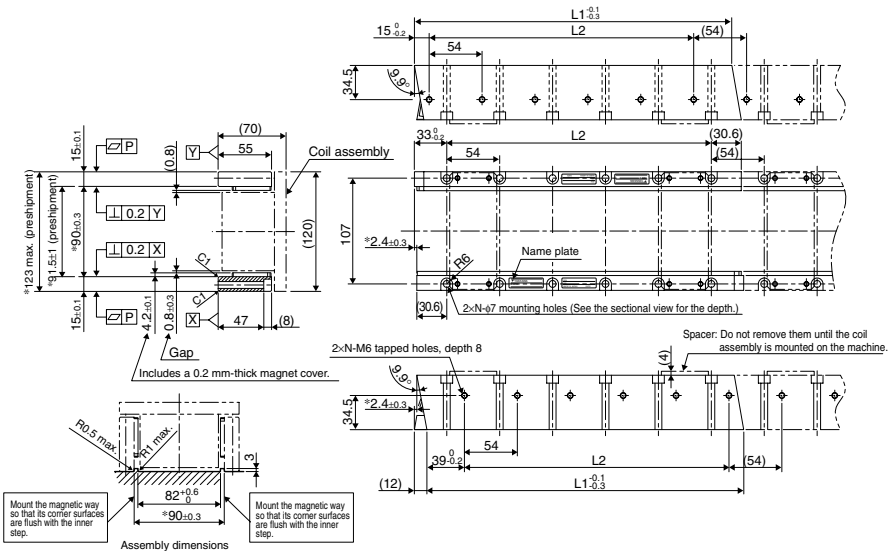

Iron-core SGLT□-50

Coil assembly: SGLTW-50D□□□H□D

Coil assembly model SGLTW-	L1	L2	(L3)	N	Approx. weight kg
50D170H□D	170	144 (48 × 3)	(16)	8	6
50D320H□D	315	(17)	14	11	

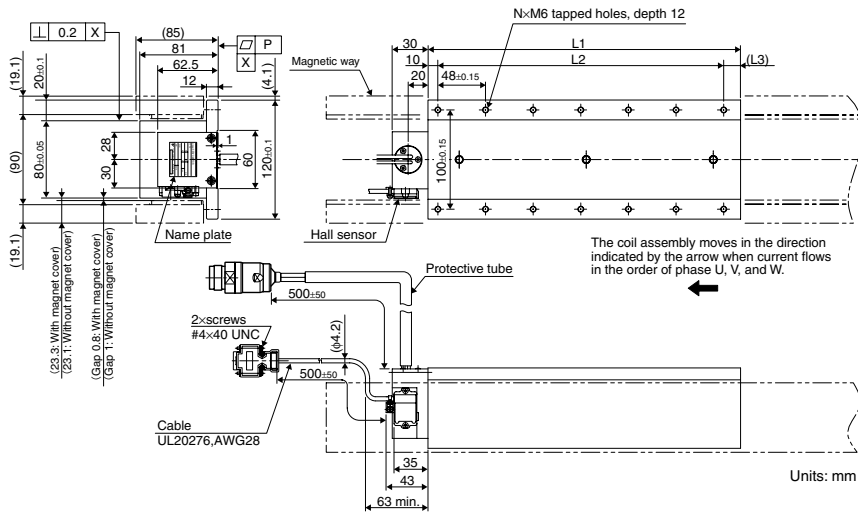

**Wiring specification of hall sensor cable**

Pin connector type: 17JE-23090-02 (D8C) made by DDK Ltd.  
The mating connector: Socket connector type: 17JE-13090-02 (D8C) Stud type: 17L-002C or 17L-002C1

Pin No.	Name
1	+5VDC
2	Phase U
3	Phase V
4	Phase W
5	0V
6	Not used
7	Not used
8	Not used
9	Not used

**Linear servo motor Connector specifications**

Extension: LPRA06AMRPN182  
Pin type: 021-279, 1020 made by Intercontron  
The mating connector: Plug type: LPRA06BFRBN170

Pin No.	Name
1	Phase U
2	Phase V
4	Phase W
5	Not used
6	Not used
⊕	Ground

**Hall sensor output signals**  
When the coil assembly moves in the direction indicated by the arrow in the figure, the relationship between the hall sensor output signals Su, Sv, Sw and the inverse power of each motor phase Vu, Vv, Vw becomes as shown in the figure below

Magnetic way: SGLTM-50□□□H

Magnetic way model SGLTM-	L1 <sup>-0.1</sup> / <sub>-0.3</sub>	L2	N	Approx. weight kg
50324H	324	270 (54 × 5)	6	8
50540H	540	486 (54 × 9)	10	13
50756H	756	702 (54 × 13)	14	18

- Note:**
- Two magnetic ways for both ends of coil assembly make one set. Spacers are mounted on magnetic ways for safety during transportation. Do not remove the spacers until the coil assembly is mounted on a machine.
  - The magnetic way may affect pacemakers. Keep a minimum distance of 200 mm from the magnetic way.
  - Two magnetic ways in a set can be connected to each other.
  - The dimensions marked with an \* are the dimensions between the magnetic ways. Be sure to follow exactly the dimensions specified in the figure above. Mount magnetic ways as shown in Assembly Dimensions. The values with an \* are the dimensions at preshipment.
  - Use socket headed screws of strength class 10.9 minimum for magnetic way mounting screws. Do not use stainless steel screws.

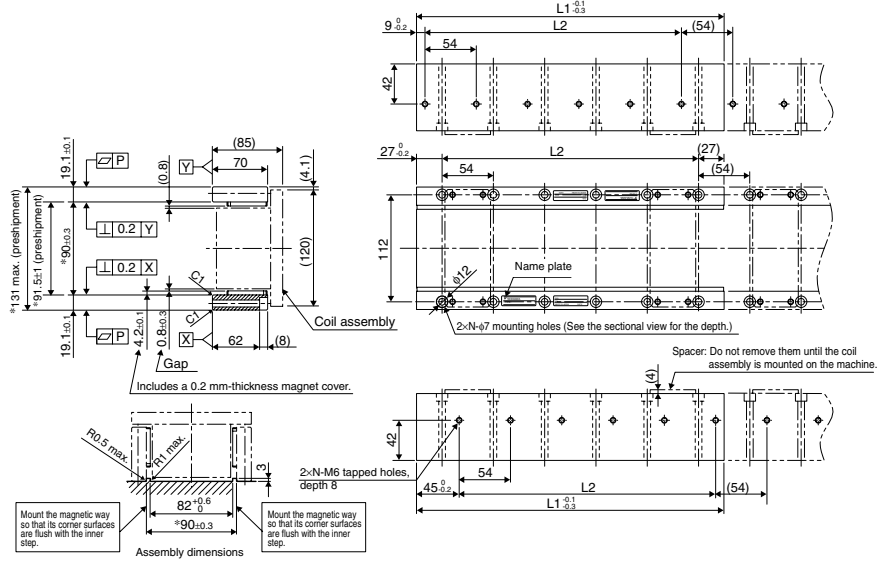

Iron-core SGLT□-40

Coil assembly: SGLTW-40D□□□B□

Coil assembly model SGLTW-	L1	L2	(L3)	N	Approx. weight kg
40D400B□	395	360 (60 × 6)	(15)	14	15
40D600B□	585	(25)	20	23	

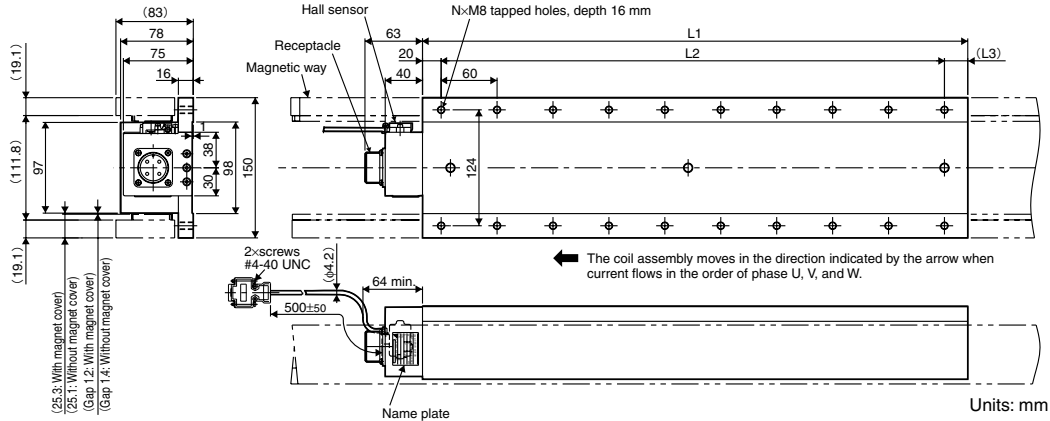

Hall sensor Connector specifications

Pin connector type: 17JE-23090-02 (D8C) made by DDK Ltd.

The mating connector

Socket connector type: 17JE-13090-02 (D8C) Stud type: 17L-002C or 17L-002C1

Pin No.	Name
1	+5V (Power supply)
2	Phase U
3	Phase V
4	Phase W
5	0V (Power supply)
6	Not used
7	Not used
8	Not used
9	Not used

Linear servo motor Connector specifications

Receptacle type: MS3102A-22-22P made by DDK Ltd.

The mating connector

L-shaped plug type: MS3108E22-22S

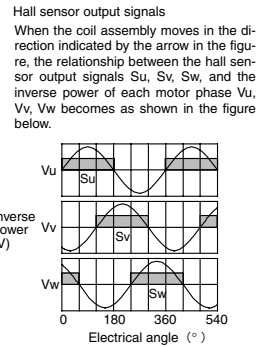

Magnetic way: SGLTM-40□□□A

Magnetic way model SGLTM-	L1 <sup>-0.1</sup> <sub>-0.3</sub>	L2	N	Approx. weight kg
40405A	405	337.5 (67.5 × 5)	6	9
40675A	675	607.5 (67.5 × 9)	10	15
40945A	945	877.5 (67.5 × 13)	14	21

- Note:**
- Two magnetic ways for both ends of coil assembly make one set. Spacers are mounted on magnetic ways for safety during transportation. Do not remove the spacers until the coil assembly is mounted on a machine.
  - The magnetic way may affect pacemakers. Keep a minimum distance of 200 mm from the magnetic way.
  - Two magnetic ways in a set can be connected to each other.
  - The dimensions marked with an \* are the dimensions between the magnetic ways. Be sure to follow exactly the dimensions specified in the figure above. Mount magnetic ways as shown in Assembly Dimensions. The values with an \* are the dimensions at preshipment.
  - Use socket headed screws of strength class 10.9 minimum for magnetic way mounting screws. Do not use stainless steel screws.

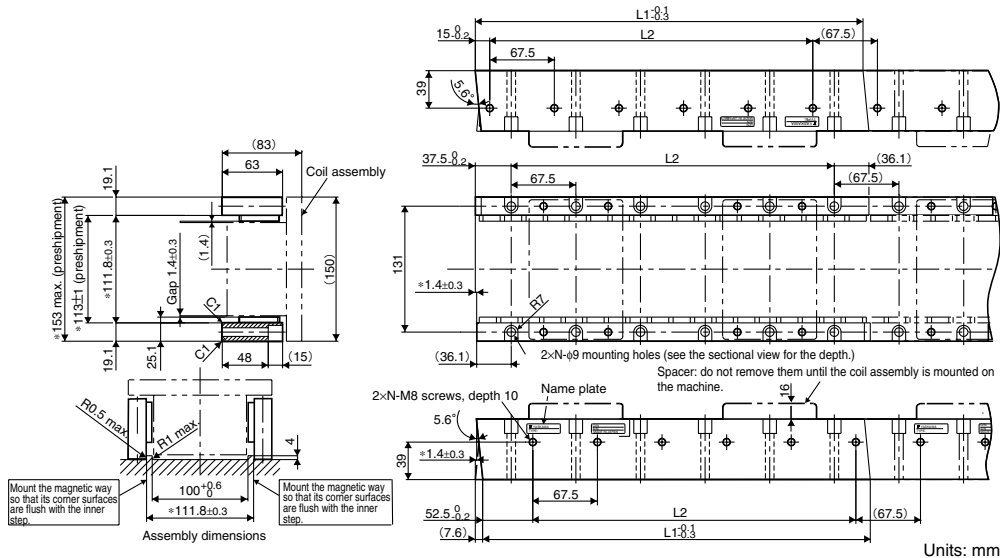

Iron-core SGLT□-80

Coil assembly: SGLTW-80□□□B□

Coil assembly model SGLTW-	L1	L2	(L3)	N	Approx. weight kg
80D400B□	395	360 (60 × 6)	(15)	14	25
80D600B□	585	(25)	20	36	

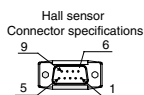
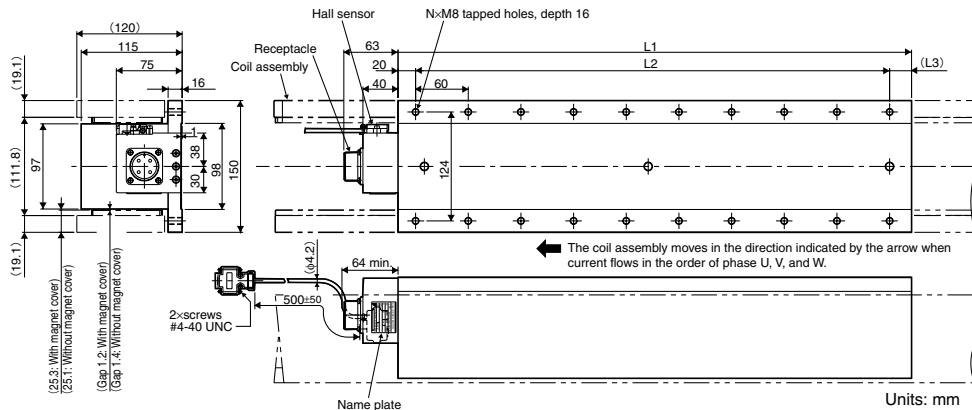

Pin connector type: 17JE-23090-02 (D8C) made by DDK Ltd.

The mating connector  
Socket connector type: 17JE-13090-02 (D8C)  
Stud type: 17L-002C or 17L-002C1

Pin No.	Name
1	+5VDC
2	Phase U
3	Phase V
4	Phase W
5	0V
6	Not used
7	Not used
8	Not used
9	Not used

Linear servo motor Connector specifications



Receptacle type: MS3102A-22-22P made by DDK Ltd.

The mating connector  
L-shaped plug type: MS3108E22-22S

Pin No.	Name
A	Phase U
B	Phase V
C	Phase W
D	Ground

Hall sensor output signals

When the coil assembly moves in the direction indicated by the arrow in the figure, the relationship between the hall sensor output signals Su, Sv, Sw and the inverse power of each motor phase Vu, Vv, Vw becomes as shown in the figure below

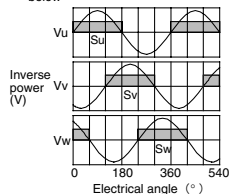

Magnetic way: SGLTM-80□□□A

Magnetic way model SGLTM-	L1 <sup>-0.1</sup> <sub>-0.3</sub>	L2	L3	N1	N2	Approx. weight kg
80405A	405	337.5 (67.5 × 5)	337.5 (33.75 × 10)	6	11	14
80675A	675	607.5 (67.5 × 9)	607.5 (33.75 × 18)	10	19	24
80945A	945	877.5 (67.5 × 13)	887.5 (33.75 × 26)	14	27	34

- Note:**
- Two magnetic ways for both ends of coil assembly make one set. Spacers are mounted on magnetic ways for safety during transportation. Do not remove the spacers until the coil assembly is mounted on a machine.
  - The magnetic way may affect pacemakers. Keep a minimum distance of 200 mm from the magnetic way.
  - Two magnetic ways in a set can be connected to each other.
  - The dimensions marked with an \* are the dimensions between the magnetic ways. Be sure to follow exactly the dimensions specified in the figure above. Mount magnetic ways as shown in assembly dimensions. The values with an \* are the dimensions at preshipment.
  - Use socket headed screws of strength class 10.9 minimum for magnetic way mounting screws. Do not use stainless steel screws.

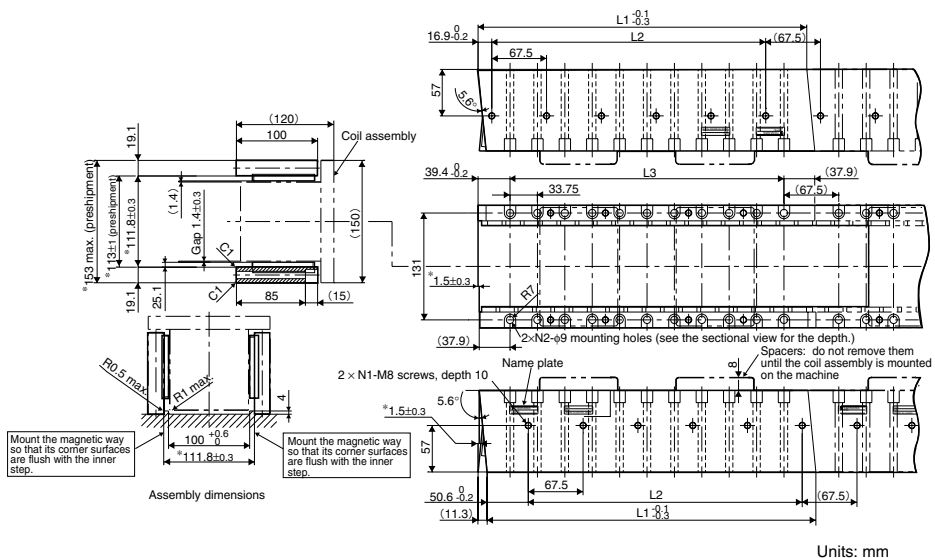

Serial converter unit

JZDP-[A/D]008-□□□

Items	Specifications	
Electrical characteristics	Power supply voltage	+5.0 V ±5%, ripple content 5% max.
	Current consumption	120 mA Typ. 350 mA max.
	Signal resolution	Input 2-phase sine wave: 1/256 pitch
	Max. response frequency	250 kHz
	Analog input signals (cos, sin, Ref)	Differential input amplitude: 0.4 V to 1.2 V input signal level: 1.5 V to 3.5 V
	Pole sensor input signal	CMOS level
	Output signals	Position data, hall sensor information, and alarms
	Output method	Serial data transmission (HDLC (High-level Data Link Control) protocol format with Manchester codes)
	Transmission cycle	62.5 μs
Mechanical characteristics	Output circuit	Balanced transceiver (SN75LBC176 or the equivalent) Internal terminal resistance: 120 Ω
	Approx. weight	150 g
	Vibration resistance	98 m/s <sup>2</sup> max. (1 to 2500 Hz) in three directions
Environmental conditions	Shock resistance	980 m/s <sup>2</sup> , (11 ms) two times in three directions
	Operating temperature	0 °C to 55 °C (32 to 131 °F)
	Storage temperature	-20 °C to +80 °C (-4 to +176 °F)
	Humidity	20 % to 90 %RH (without condensation)

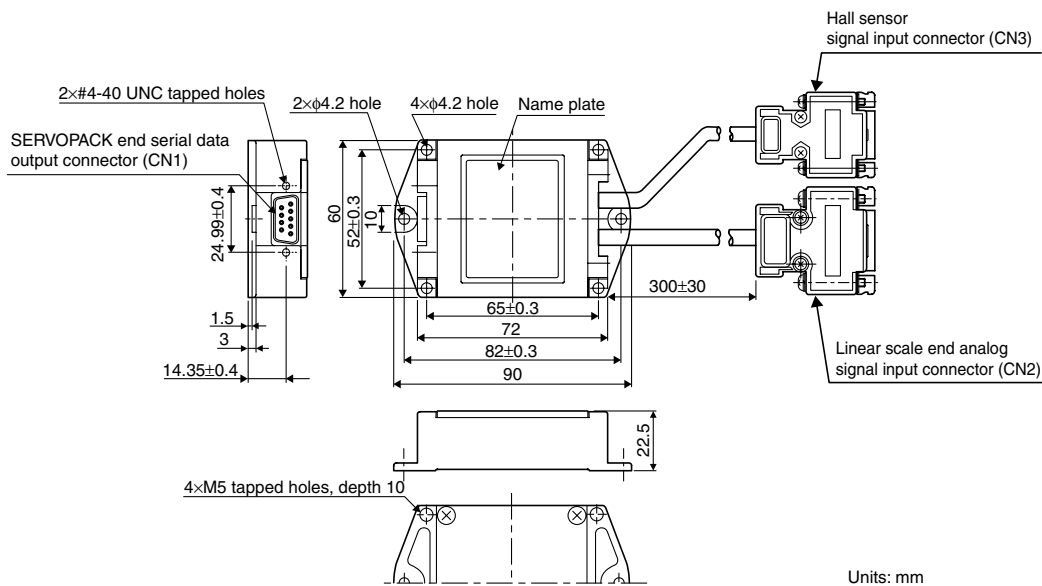

Units: mm

**CN1**  
SERVOPACK end serial data output

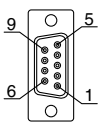

Pin No.	Signal
1	+5V
2	S-phase output
3	Empty
4	Empty
5	0V
6	/S-phase output
7	Empty
8	Empty
9	Empty
Case	Shield

**CN2**  
Linear scale end analog signal input

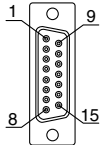

Pin No.	Signal
1	/cos input (V1-)
2	/sin input (V2-)
3	Ref input (V0+)
4	+5V
5	5Vs
6	Empty
7	Empty
8	Empty
9	cos input (V1+)
10	sin input (V2+)
11	/Ref input (V0-)
12	0V
13	0Vs
14	Empty
15	Inner shield
Case	Shield

**CN3**  
Hall sensor signal input

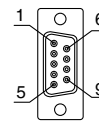

Pin No.	Signal
1	+5V
2	U-phase input
3	V-phase input
4	W-phase input
5	0V
6	Empty
7	Empty
8	Empty
9	Empty
Case	Shield

**Note:** 1. Do not use empty pins.

2. The linear scale (analog 1Vp-p output, D-sub 15-pin, male) by Renishaw Inc. can be directly connected. However, the BID and DIR signals are not connected.

3. Use the linear scale end connector to change the zero point specifications of the linear scale.

Ordering information

(Refer to servo drive chapter)

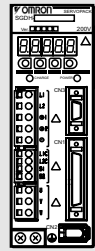

④ Sigma-II Servo Drive  
Servo drive with option boards for flexible system configuration

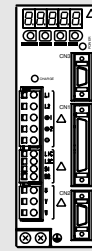

④ XtraDrive  
Intelligent Servo Drive

Drive options

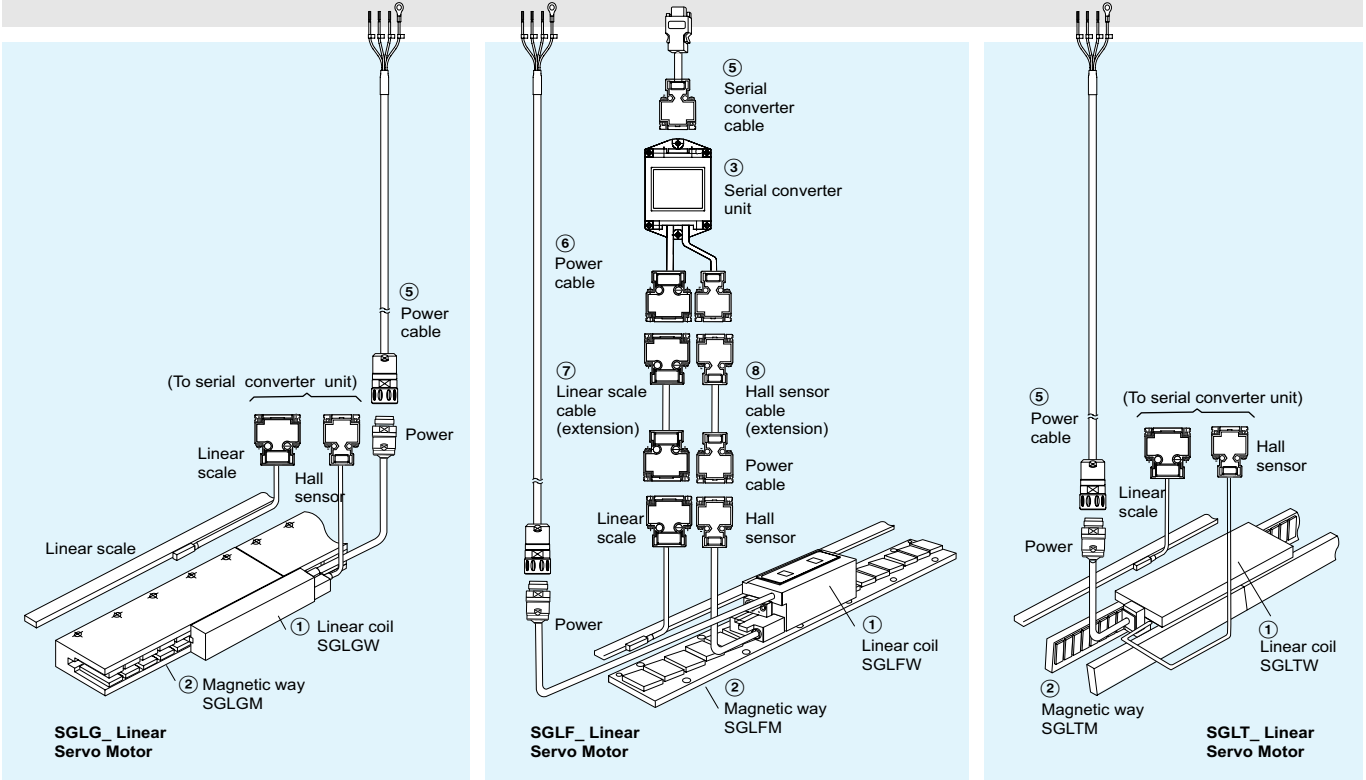

**Note:** The symbols ①②③... show the recommended sequence to select the servo motor, cables and serial converter for a linear motor system

Servo motor

SGLGW / SGLGM coreless type (200 V)

With standard-force magnetic ways - 230 VAC single phase

Symbol	Specifications		Model				
	Rated force	Peak force	① Linear coil	② Magnetic way	③ Serial converter	④ Servo drive	
	12.5 N	40 N	SGLGW-30A050CPD	SGLGM-30108A SGLGM-30216A SGLGM-30432A	JZDP-D008-250	Sigma-II series	
						25 N	80 N
	47 N	140 N	SGLGW-40A140CPD	SGLGM-40090CT SGLGM-40225CT	JZDP-D008-252		
						93 N	280 N
	140 N	420 N	SGLGW-40A365CPD	SGLGM-60090CT SGLGM-60225CT SGLGM-60360CT SGLGM-60405CT SGLGM-60450CT	JZDP-D008-254		
						70 N	220 N
	140 N	440 N	SGLGW-60A253CPD	SGLGM-60450CT	JZDP-D008-259		
						210 N	660 N
	325 N	1300 N	SGLGW-90A200CPD	SGLGM-90252A SGLGM-90504A	JZDP-D008-264		

**Note:** 1. Linear coils with design revision C replace the previous versions A and B. The serial converter required for revision C coil has changed from previous version, select it according to the table above  
 2. Magnetic ways with design revision CT and revision B can be combined

With high-force magnetic ways - 230 VAC single phase

Symbol	Specifications		Model				
	Rated force	Peak force	① Linear coil	② Magnetic way	③ Serial converter	④ Servo drive	
						Sigma-II series	XtraDrive
 ①②③④	57 N	230 N	SGLGW-40A140CPD	SGLGM-40090CT-M SGLGM-40225CT-M	JZDP-D008-255	SGDH-02AE-OY	XD-02-MN01
	114 N	460 N	SGLGW-40A253CPD	SGLGM-40360CT-M SGLGM-40405CT-M SGLGM-40450CT-M	JZDP-D008-256	SGDH-04AE-OY	XD-04-MN01
	171 N	690 N	SGLGW-40A365CPD		JZDP-D008-257	SGDH-08AE-S-OY	XD-08-MN
	85 N	360 N	SGLGW-60A140CPD	SGLGM-60090CT-M	JZDP-D008-261	SGDH-02AE-OY	XD-02-MN01
	170 N	720 N	SGLGW-60A253CPD	SGLGM-60225CT-M	JZDP-D008-262	SGDH-08AE-S-OY	XD-08-MN
	255 N	1080 N	SGLGW-60A365CPD	SGLGM-60360CT-M SGLGM-60405CT-M SGLGM-60450CT-M	JZDP-D008-263	SGDH-15AE-S-OY	XD-15-MN

**Note:** 1. Linear coils with design revision C replace the previous versions A and B. The serial converter required for revision C coil has changed from previous version, select it according to the table above  
 2. Magnetic ways with design revision CT and revision B can be combined

SGLFW / SGLFM iron-core type

230 VAC single phase

Symbol	Specifications		Model				
	Rated force	Peak force	① Linear coil	② Magnetic way	③ Serial converter	④ Servo drive	
						Sigma-II series	XtraDrive
 ①②③④	25 N	86 N	SGLFW-20A090APD	SGLFM-20324AC	JZDP-A008-017	SGDH-02AE-OY	XD-02-MN01
	40 N	125 N	SGLFW-20A120APD	SGLFM-20540AC SGLFM-20756AC	JZDP-A008-018	SGDH-02AE-OY	XD-02-MN01
	80 N	220 N	SGLFW-35A120APD	SGLFM-35324AC	JZDP-A008-019	SGDH-02AE-OY	XD-02-MN01
	160 N	440 N	SGLFW-35A230APD	SGLFM-35540AC SGLFM-35756AC	JZDP-A008-020	SGDH-08AE-S-OY	XD-08-MN01
	280 N	600 N	SGLFW-50A200BPD	SGLFM-50135AC	JZDP-A008-181	SGDH-08AE-S-OY	XD-08-MN
	560 N	1200 N	SGLFW-50A380BPD	SGLFM-50405AC SGLFM-50675AC SGLFM-50945AC	JZDP-A008-182	SGDH-15AE-S-OY	XD-15-MN
	560 N	1200 N	SGLFW-1ZA200BPD	SGLFM-1Z135AC SGLFM-1Z405AC SGLFM-1Z675AC SGLFM-1Z945AC	JZDP-A008-183	SGDH-15AE-S-OY	XD-15-MN

**Note:** Serial converters with design revision A (JZDP-A008-xxx) will be replaced by revision D (JZDP-D008-xxx), both models are fully compatible

400 VAC three phase

Symbol	Specifications		Model				
	Rated force	Peak force	① Linear coil	② Magnetic way	③ Serial converter	④ Servo drive	
						Sigma-II series	XtraDrive
 ①②③④	80 N	220 N	SGLFW-35D120APD	SGLFM-35324AC	JZDP-A008-211	SGDH-05DE-OY	XD-05-TN
	160 N	440 N	SGLFW-35D230APD	SGLFM-35540AC SGLFM-35756AC	JZDP-A008-212	SGDH-05DE-OY	XD-05-TN
	280 N	600 N	SGLFW-50D200BPD	SGLFM-50135AC	JZDP-A008-189	SGDH-10DE-OY	XD-10-TN
	560 N	1200 N	SGLFW-50D380BPD	SGLFM-50405AC SGLFM-50675AC SGLFM-50945AC	JZDP-A008-190	SGDH-15DE-OY	XD-15-TN
	560 N	1200 N	SGLFW-1ZD200BPD	SGLFM-1Z135AC	JZDP-A008-191	SGDH-15DE-OY	XD-15-TN
	1120 N	2400 N	SGLFW-1ZD380BPD	SGLFM-1Z405AC SGLFM-1Z675AC SGLFM-1Z945AC	JZDP-A008-192	SGDH-30DE-OY	XD-30-TN
	1500 N	3600 N	SGLFW-1ED380BP	SGLFM-1E135AC	JZDP-D008-333	SGDH-20DE-OY	XD-20-TN
	2250 N	5400 N	SGLFW-1ED560BP		JZDP-D008-334	SGDH-30DE-OY	XD-30-TN

**Note:** Serial converters with design revision A (JZDP-A008-xxx) will be replaced by revision D (JZDP-D008-xxx), both models are fully compatible

SGLTW / SGLTM iron-core type

400 VAC three phase

Symbol	Specifications		Model				
	Rated force	Peak force	① Linear coil	② Magnetic way	③ Serial converter	④ Servo drive	
						Sigma-II series	XtraDrive
 ①②③④	300 N	600 N	SGLTW-35D170HPD	SGLTM-35324HC	JZDP-D008-193	SGDH-10DE-OY	XD-10-TN
	600 N	1200 N	SGLTW-35D320HPD	SGLTM-35540HC SGLTM-35756HC	JZDP-D008-194	SGDH-20DE-OY	XD-20-TN
	450 N	900 N	SGLTW-50D170HPD	SGLTM-50324HC	JZDP-D008-195	SGDH-10DE-OY	XD-10-TN
	900 N	1800 N	SGLTW-50D320HPD	SGLTM-50540HC SGLTM-50756HC	JZDP-D008-196	SGDH-20DE-OY	XD-20-TN
	670 N	2600 N	SGLTW-40D400BP	SGLTM-40405AC	JZDP-D008-197	SGDH-30DE-OY	XD-30-TN
	1000 N	4000 N	SGLTW-40D600BP	SGLTM-40675AC SGLTM-40945AC	JZDP-D008-198	SGDH-50DE-OY	XD-50-TN
	1300 N	5000 N	SGLTW-80D400BP	SGLTM-80405AC	JZDP-D008-199	SGDH-50DE-OY	XD-50-TN
	2000 N	7500 N	SGLTW-80D600BP	SGLTM-80675AC SGLTM-80945AC	JZDP-D008-200	SGDH-75DE-OY	-



**Servo drive**

**Note:** Choosing Sigma-II drive or XtraDrive affects to the serial converter cable needed.

④ Refer to Sigma-II servo drive or XtraDrive chapter for detailed drive specifications and selection of drive accessories.

**Serial converter cable to servo drive**

Symbol	Specifications	Model	Appearance	
⑤	Sigma-II drive to serial converter cable	3 m	JZSP-CLP70-03-E	
		5 m	JZSP-CLP70-05-E	
		10 m	JZSP-CLP70-10-E	
		15 m	JZSP-CLP70-15-E	
		20 m	JZSP-CLP70-20-E	
	XtraDrive drive to serial converter cable	3 m	XD-CLP70-03-E	
		5 m	XD-CLP70-05-E	
		10 m	XD-CLP70-10-E	
		15 m	XD-CLP70-15-E	
		20 m	XD-CLP70-20-E	

**Power cables**

Symbol	Specifications	Model	Appearance	
⑥	For 200 V servo motors SGLGW-30A□□□□□□D SGLGW-40A□□□□□□D SGLGW-60A□□□□□□D SGLFW-20A□□□□A□D SGLFW-35A□□□□A□D	3 m	R88A-CAWA003S-DE	
		5 m	R88A-CAWA005S-DE	
		10 m	R88A-CAWA010S-DE	
		15 m	R88A-CAWA015S-DE	
		20 m	R88A-CAWA020S-DE	
	For 200 V servo motors SGLGW-90A200□□□D SGLFW-50A□□□□B□D SGLFW-1ZA200B□□D	3 m	R88A-CAWB003S-DE	
		5 m	R88A-CAWB005S-DE	
		10 m	R88A-CAWB010S-DE	
		15 m	R88A-CAWB015S-DE	
		20 m	R88A-CAWB020S-DE	
	For 400 V servo motors SGLFW-35D□□□□A□D SGLFW-50D200□□D SGLTW-35D170H□□D SGLTW-50D170H□□D	3 m	R88A-CAWK003S-DE	
		5 m	R88A-CAWK005S-DE	
		10 m	R88A-CAWK010S-DE	
		15 m	R88A-CAWK015S-DE	
		20 m	R88A-CAWK020S-DE	
	For 400 V servo motors SGLFW-50D380□□D SGLFW-1ZD□□□□B□D SGLTW-35D320H□□D SGLTW-50D320H□□D	3 m	R88A-CAWL003S-DE	
		5 m	R88A-CAWL005S-DE	
		10 m	R88A-CAWL010S-DE	
		15 m	R88A-CAWL015S-DE	
		20 m	R88A-CAWL020S-DE	
For 400 V servo motors SGLFW-1ED□□□□B□□ SGLTW-40D□□□□B□□ SGLTW-80D□□□□B□□	3 m	R88A-CAWD003S-E		
	5 m	R88A-CAWD005S-E		
	10 m	R88A-CAWD010S-E		
	15 m	R88A-CAWD015S-E		
	20 m	R88A-CAWD020S-E		

**Linear scale cable to serial converter**

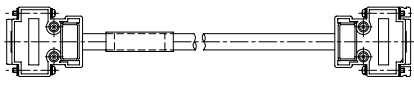
Symbol	Specifications	Model	Appearance	
⑦	Extension cable for <b>Renishaw</b> linear scale to serial converter. (Connector DB-15) (the extension cable is optional)	1 m	JZSP-CLL00-01-E	
		3 m	JZSP-CLL00-03-E	
		5 m	JZSP-CLL00-05-E	
		10 m	JZSP-CLL00-10-E	
		15 m	JZSP-CLL00-15-E	
	Extension cable for <b>Heidenhain</b> linear scale to serial converter (Connector DB-15) (when a Heidenhain scale is used the extension cable is required)	1 m	JZSP-CLL20-01-E	
		3 m	JZSP-CLL20-03-E	
		5 m	JZSP-CLL20-05-E	
		10 m	JZSP-CLL20-10-E	
		15 m	JZSP-CLL20-15-E	

**Hall sensor cable to serial converter**

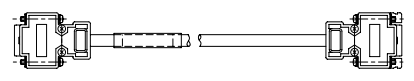
Symbol	Specifications	Model	Appearance	
⑧	Extension cable for linear scale to serial converter (The extension cable is optional)	1 m	JZSP-CLL10-01-E	
		3 m	JZSP-CLL10-03-E	
		5 m	JZSP-CLL10-05-E	
		10 m	JZSP-CLL10-10-E	
		15 m	JZSP-CLL10-15-E	

**Connectors**

Specification	Model
Hypertac power connector IP67 (for 200 V motor coils SGL□W-□□A□□□□□D)	SPOC-06K-FSDN169
Hypertac power connector IP67 (for 400 V motor coils SGL□W-□□D□□□□□□D)	LPRA-06B-FRBN170
Military power connector IP67 (for motor coils SGLTW-40□/80□ and SGLFW-1ED□)	MS3108E22-22S

**Dimensioning software**

Specifications	Model
SigmaSize	MOTION TOOLS CD

ALL DIMENSIONS SHOWN ARE IN MILLIMETERS.  
To convert millimeters into inches, multiply by 0.03937. To convert grams into ounces, multiply by 0.03527.