

SG-BODY COMPACT MUTING SERIES

Safety light curtains with infrared beams

QUICK GUIDE

SAFETY INFORMATION



The following points must be observed for a correct and safe use of the safety light curtains of the SG-BODY COMPACT series:

- The stopping system of the machine must be electrically controlled.
- This control system must be able to stop the dangerous movement of the machine within the total machine stopping time T as per paragraph 2.2.1 of the manual included in the CD supplied and during all working cycle phases.
- Mounting and connection of the safety light curtain must be carried out only by qualified personnel, according to the indications included in the special sections (refer to sections 2; 3; 4; 5) and in respect to the applicable Standards.
- The safety light curtain must be securely installed so that access to the dangerous zone is not possible without interrupting the beams.
- The personnel operating in the dangerous area must be well-trained and must have adequate knowledge of all the operating procedures of the safety light curtain.
- The TEST, RESET/RESTART and OVERRIDE buttons must be located outside the protected area as the operator must check the protected area during all Test, Restart and Override operations.
- Please carefully read the instructions for the correct functioning before powering the light curtain.

Precautions to be observed for the choice and installation of the device



Make sure that the protection level assured by the SG-BODY COMPACT device (Type2/Type4) is compatible with the real danger level of the machine to be controlled, according to EN 954-1 and EN 13849-1.

- The outputs (OSSD) of the ESPE must be used as machine stopping devices and not as command devices. The machine must have its own START command.
- The dimension of the smallest object to be detected must be larger than the resolution level of the device.
- The ESPE must be installed in a room complying with the technical characteristics indicated in section 9 "Technical data" of the manual included in the CD supplied.
- Do not place the device near intense and/or flashing light sources and, in particular, close to receiving unit front surface.
- The presence of intense electromagnetic disturbances could jeopardise device operation. This condition has to be carefully evaluated with the support of the DATALOGIC AUTOMATION Technical service.
- The operating distance of the device can be reduced in presence of smog, fog or airborne dust.
- A sudden change in environment temperature, with very low minimum peaks, can generate a small condensation layer on the lenses and so jeopardise functioning.
- Reflecting surfaces near the safety light curtain light beam (above, under or lateral) can cause passive reflections that can jeopardise functioning.
- The safety device must be installed at a distance which is major or equal to the minimum safety distance S to ensure that the operator can not reach the dangerous area until the moving dangerous object has been blocked by the ESPE.



The failure to respect the safety distance reduces or cancels ESPE the protection function. For more detailed information about calculation of safety distance, please refer to the complete manual contained in the CD supplied.

CONNECTIONS

RECEIVER (RX)

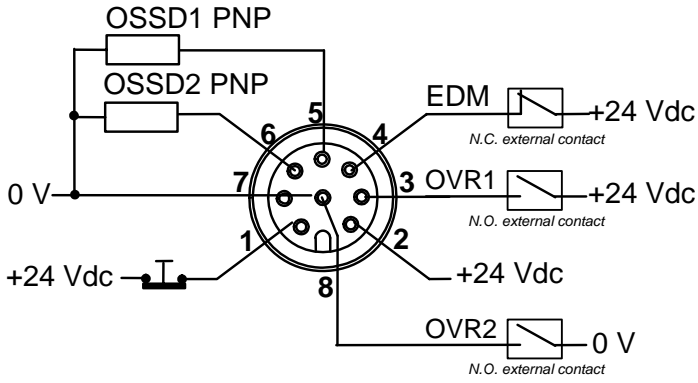

EMITTER (TX)

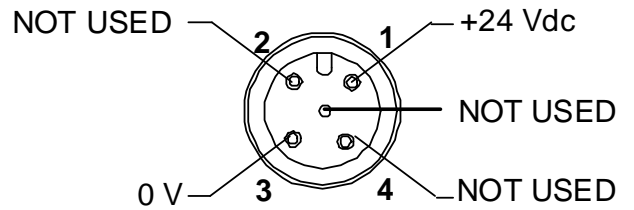
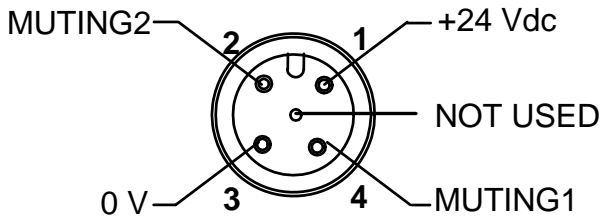
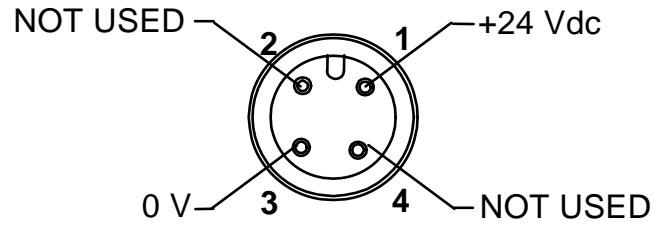

M12 8 Poles:

- 1 = white = TEST/START
- 2 = brown = +24 Vdc
- 3 = green = OVERRIDE 1
- 4 = yellow = EDM
- 5 = grey = OSSD1
- 6 = pink = OSSD2
- 7 = blue = 0 V
- 8 = red = OVERRIDE 2

M12 5 Poles:

- 1 = brown = +24 Vdc
- 2 = white = MUTING2
- 3 = blue = 0 V
- 4 = black = MUTING1
- 5 = grey = NOT USED

M12 4 Poles:

- 1 = brown = +24 Vdc
- 2 = white = NOT USED
- 3 = blue = 0 V
- 4 = black = NOT USED

M12 5 Poles:

- 1 = brown = +24 Vdc
- 2 = white = NOT USED
- 3 = blue = 0 V
- 4 = black = NOT USED
- 5 = grey = NOT USED

ALIGNMENT PROCEDURE

The alignment between the emitting and the receiving units is necessary to obtain the correct functioning of the light curtain. A good alignment prevents output instability caused by dust or vibrations. The alignment is perfect if the optical axes of the first and the last emitting unit beams coincide with the optical axes of the corresponding elements of the receiving unit.

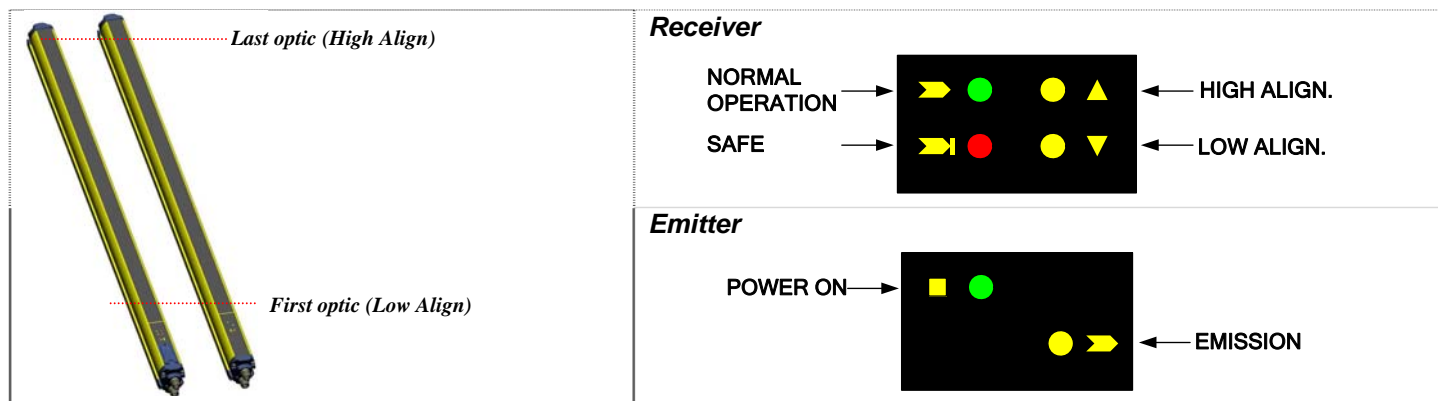

Signals are clearly identified through symbols allowing immediate reading, independent of bars directions.

A short description of the signalling LEDs is necessary to avoid misunderstandings.

Two yellow LEDs (▲ HIGH ALIGN, ▼ LOW ALIGN) on SG-BODY COMPACT receiver, facilitate the alignment procedure.

Correct alignment procedure



The light curtain alignment can be effected only after having completed the mechanical installation and the electrical connections. The following procedure has to be followed:

NOTE: SG-BODY is equipped with a system which informs the user on the alignment obtained.

The alignment function can be activated when powering the device, by keeping the TEST/START pressed.

- Disconnect the power supply to **SAFEasy™**.
 - Press the TEST/START button and keep it pressed (open the contact).
 - Re-connect the power supply.
 - Release the TEST/START button.
 - Check the green LED on the bottom of the TX unit (POWER ON) and the yellow LED (NORMAL OPERATION); if they are ON, the unit is running correctly.
 - Verify that one of the following conditions is present on the RX unit:
 1. Red LED (SAFE) ON: non-alignment condition.
 2. Green LED (NORMAL OPERATION) ON: light curtain already aligned condition; in this case also the two yellow LEDs will be ON (HIGH ALIGN, LOW ALIGN).
 - Continue with the following steps to change from condition 1 to condition 2:
 - A** Keep the receiving unit in a steady position and set the transmission unit until the yellow LED on the bottom (LOW ALIGN) is ON. This condition shows the effective alignment of the first lower beam.
 - B** Rotate the transmission unit until the upper yellow LED (HIGH ALIGN) is ON; in this conditions red LED (SAFE) must turn off and green LED (NORMAL OPERATION) must turn ON.
- Note: ensure that the green LED (NORMAL OPERATION) modo is ON and steady.**
- C** Delimit the area in which the green LED (NORMAL OPERATION) is steady through some micro adjustments - for the first and then for the second unit - then place both units in the centre of this area.
- Fix the two units firmly using pins and brackets.
 - Disconnect the power supply to **SAFEasy™**.
 - Re-connect the power supply.
 - Verify that the green LED is ON on the RX unit (condition where the beams are free, NORMAL OPERATION) and verify that, if even one single beam is obscured, the green LED turns OFF and the red LED turns ON (condition where an object has been detected, SAFE).

DIP SWITCHES CONFIGURATION

-  The device does not accept configuration changes during normal functioning. A change is accepted only beginning from the successive powering of the device. Particular attention has to be taken during the configuration dip-switch management and use.
-  **Muting time-out “∞” does not comply with the requirements of IEC 61496-1. Therefore all possible risks must be considered and related precautions undertaken before selecting the “∞” option.**

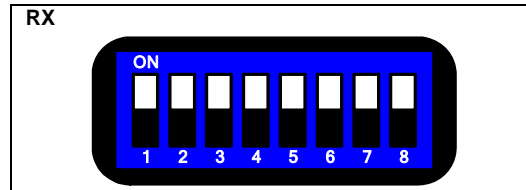

NOTE: Each function is associated with two different dip-switches; it is necessary that the two different dip-switches associated to a particular function are configured in the same way. The “ON” position is the default.





dip-sw	Function	ON	OFF
1,5	Muting time-out	10 min.	∞
2,6	Muting	T config. (4 beams)	L config. (2 beams)
3,7	EDM	Deactivated	Activated
4,8	Reset	Automatic	Manual

DIAGNOSTICS FUNCTION

The operator can visualise the operating condition of the light curtains thanks to four LEDs on the RX unit and two LEDs on the TX unit. By means of these LEDs the operator can evaluate the main causes of the system stopping or failure. For the receiver:

Failure	Cause	Check and repair
<p><i>OFF</i> <i>Blinking yellow</i></p>  <p><i>Blinking red</i> <i>Blinking yellow</i></p>	Output failure	<ul style="list-style-type: none"> - Check the output connections. - Check if the load characteristics are in accordance with the Technical data (see section 9)
<p><i>OFF</i> <i>OFF</i></p>  <p><i>Blinking red</i> <i>Blinking yellow</i></p>	Failure of external switching device (EDM test function)	<ul style="list-style-type: none"> - Control the EDM connections - Check the compatibility of external switching device with EDM test time - Switch OFF and switch ON the devices; if failure persists replace external switching device
<p><i>OFF</i> <i>Blinking yellow</i></p>  <p><i>OFF</i> <i>Blinking yellow</i></p>	Microprocessor failure	<ul style="list-style-type: none"> - Check the correct positioning of the configuration dip-switches. - Switch OFF and switch ON the device; if the failure continues contact DATALOGIC AUTOMATION
<p><i>OFF</i> <i>Blinking yellow</i></p>  <p><i>Red ON</i> <i>OFF</i></p>	It's possible to require Override	<ul style="list-style-type: none"> - The signalling is NOT a failure. - Activate override to remove material from the protected zone.
<p><i>OFF</i> <i>Blinking yellow</i></p>  <p><i>Red ON</i> <i>Blinking yellow</i></p>	Override connection failure.	<ul style="list-style-type: none"> - Check connections of the override input lines.
<p><i>OFF</i> <i>OFF</i></p>  <p><i>OFF</i> <i>Blinking yellow</i></p>	Optic failure	<ul style="list-style-type: none"> - Check unit alignment. - Switch OFF and switch ON the device; if the failure continues contact DATALOGIC AUTOMATION
<p><i>Blinking green</i> <i>Blinking yellow</i></p>  <p><i>OFF</i> <i>Blinking yellow</i></p>	Failure of the integrated Muting signalling lamp	<ul style="list-style-type: none"> - Switch OFF and switch ON the device; if the failure continues contact DATALOGIC AUTOMATION.
<p><i>OFF</i> <i>OFF</i></p>  <p><i>OFF</i> <i>OFF</i></p>	Power supply failure or the power supply voltage is outside the allowed range. Main microprocessor failure	<ul style="list-style-type: none"> - Check power supply. - Switch OFF and switch ON the device; if the failure continues contact DATALOGIC AUTOMATION

For emitter:

Failure	Cause	Check and repair
<p><i>Green ON</i></p>  <p><i>Blinking yellow</i></p>	Emitter side generic failure	<ul style="list-style-type: none"> - Check the power supply; if the failure continues contact DATALOGIC AUTOMATION and replace both units
<p><i>OFF</i></p>  <p><i>OFF</i></p>	Power supply failure	<ul style="list-style-type: none"> - Check the power supply; if the failure continues contact DATALOGIC AUTOMATION.
<p><i>Green ON</i></p>  <p><i>OFF</i></p>	The power supply voltage is outside the allowed range Main microprocessor failure	<ul style="list-style-type: none"> - Check the power supply; if the failure continues contact DATALOGIC AUTOMATION.

ORIGINAL INSTRUCTIONS (ref. 2006/42/EC)

This product is covered by one or more of the following patents.
Italian Patent IT 1,363,719 Additional patents pending

DECLARATION OF CONFORMITY

We DATALOGIC AUTOMATION declare under our sole responsibility that these products are conform to the IEC 61496-1 (2004) and IEC 61496-2 (2006) Standards and successive amendments

WARRANTY

DATALOGIC AUTOMATION warrants its products to be free from defects.
DATALOGIC AUTOMATION will repair or replace, free of charge, any product found to be defective during the warranty period of 36 months from the manufacturing date.
This warranty does not cover damage or liability deriving from the improper application of DATALOGIC AUTOMATION products.



DATALOGIC AUTOMATION

Via Lavino 265 - 40050 Monte S.Pietro - Bologna – Italy
Tel: +39 051 6765611 - Fax: +39 051 6759324
www.automation.datalogic.com e-mail:info.automation.it@datalogic.com

 DATALOGIC AUTOMATION cares for the environment: 100% recycled paper.
DATALOGIC AUTOMATION reserves the right to make modifications and improvements without prior notification.

Datalogic and the Datalogic logo are registered trademarks of Datalogic S.p.A. in many countries, including the U.S.A. and the E.U.