



MATRIX 210™



Host Mode Programming



Datalogic Automation Srl
Via Lavino, 265
40050 - Monte S. Pietro
Bologna - Italy

Matrix 210™ Host Mode Programming

Ed.: 02/2013

This manual refers to software release 6.50.

© 2011 - 2013 Datalogic Automation S.r.l. ♦ ALL RIGHTS RESERVED. ♦ Protected to the fullest extent under U.S. and international laws. Copying, or altering of this document is prohibited without express written consent from Datalogic Automation S.r.l.

Datalogic and the Datalogic logo are registered trademarks of Datalogic S.p.A. in many countries, including the U.S.A. and the E.U.

Matrix 210, ID-NET, VisiSet and X-PRESS are trademarks of Datalogic Automation S.r.l. All other brand and product names mentioned herein are for identification purposes only and may be trademarks or registered trademarks of their respective owners.

Datalogic shall not be liable for technical or editorial errors or omissions contained herein, nor for incidental or consequential damages resulting from the use of this material.

CONTENTS

1	HOST MODE PROGRAMMING	1
2	PROGRAMMING COMMANDS	2
2.1	Connection To Device	2
2.2	Disconnection From Device	2
2.3	Reader Information	3
2.4	Programmable Button Functions	3
2.5	Other Functions	4
3	PROGRAMMING STRINGS	5
3.1	Definitions	5
3.2	How To Send a Single Parameter To The Reader	8
3.3	How To Get a Single Parameter From The Reader	9
3.4	Data Storage Commands	10
3.5	How To Program An ID-NET™ Slave Reader	13
3.6	How To Get a Single Parameter From An ID-NET™ Slave Reader	14
3.7	Examples	17
4	MATRIX 210™ PARAMETERS LIST	20
4.1	Operating Mode	20
4.2	Calibration	23
4.3	Communication	24
4.4	Ethernet	26
4.5	CBX Ethernet TCP/IP	28
4.6	WebSentinel	31
4.7	Transfer Array Image	31
4.8	Reading System Layout	32
4.9	CBX Gateway	33
4.10	Image Processing	36
4.11	2D Codes	36
4.12	1D Codes	38
4.13	Postal Codes	42
4.14	Data Collection	42
4.15	Digital I/O	55
4.16	LEDs And Keypad	59
4.17	Display	62
4.18	Diagnostics	62
4.19	Match Code	65
4.20	Symbol Verification	68
4.21	Miscellaneous	69
4.22	OCR OCV	70
4.23	Data Matrix Settings (for DPM)	71
A	DIRECT COMMANDS FROM HOST	74
B	CBX GATEWAY FIELDBUS RESET	76
C	ASCII TABLE	77

CONVENTIONS

The notation in this manual uses angular brackets (< >), to represent **single byte character values** which are equivalent. See ASCII Table in appendix C.

- For special keys or some non-printable characters, the ASCII symbol for the character name is shown between angular brackets.

Example: <ESC> means the ESC key character byte
 <STX> means the start transmission character byte

- For non-printable characters, the decimal value of the character byte is shown between angular brackets.

Example: <13><10> = Carriage Return character byte, Line Feed character byte

- For special commands, the hexadecimal value of the character byte is shown between angular brackets. These commands show the value with an H subscript.

Example: 10<FE_H><FD_H> = Parameter depth #10

The following representations using these three methods are equivalent:

<ESC> = <27> = <1B_H>
and each send character byte 0x1B to the reader

The program used to generate the strings for Host Mode Programming must be able to manage them correctly.

1 HOST MODE PROGRAMMING

An alternative method of programming the Matrix 210™ devices is by sending programming strings over one of the serial interfaces.

These strings take the form of ESCAPE sequences and are transmitted from the Host system to the Matrix reader on the following interfaces:

- Auxiliary RS232 serial interface and Main RS232/RS485 serial interface (for Matrix 210 2xx-x0x Serial models and Matrix 210 2xx-x1x Ethernet models)
- Ethernet interface (only for Matrix 210 2xx-x1x Ethernet models)
- Optional CBX500 Host Interface (Ethernet TCP/IP, Profibus, DeviceNet, etc.).
- USB interface (only for Matrix 210 2xx-x2x USB models)

This is called Host Mode programming.

If Host Mode programming is performed over the RS485 half-duplex (polled) main interface, MUX32 Protocol must be used.

In order to send the programming strings, it is necessary to switch the reader into **Host Mode**.

**NOTE**

Digital Outputs 1, 2 can be used to indicate when the device is in Host Mode by setting the related parameter: Activation Events = Host Control Mode.

**WARNING**

VisiSet™ must not be connected to the reader through the selected interface before entering in Host Mode.

Serial Interfaces

The programming commands and strings must be sent to the reader at the programmed baud rate of the selected serial interface (e.g. if the baud rate of the Auxiliary interface is programmed at 9600 bps the command must be sent at 9600 bps).

Ethernet Interface

The programming commands and strings must be sent to the reader at the programmed baud rate using the dedicated Ethernet System Socket (Port Number: 51235) or the configured Data Socket (configurable Port Number).

USB Interface

The programming commands and strings must be sent to the reader at the programmed baud rate of the USB serial interface (e.g. if the baud rate of the Auxiliary interface is programmed at 921600 bps the command must be sent at 921600 bps).

2 PROGRAMMING COMMANDS

2.1 CONNECTION TO DEVICE

	DESCRIPTION	HOST COMMAND	REPLY MESSAGE
1	Enter Host Mode	<ESC> [C	<ESC> H <CR><LF>
	After entering this command, the device responds with the first reply message and then waits for the following command.		
2	Enter Programming Mode	<ESC> [B	<ESC> Q <CR><LF>
	After entering this command, the device responds with the second reply message and or one or more programming strings as shown in Chapter 3.		

2.2 DISCONNECTION FROM DEVICE

	DESCRIPTION	HOST COMMAND	REPLY MESSAGE
1	End of Single Parameter Programming Sequence	<ESC> I A #	<ESC> K <CR><LF> <ESC> W 1 <CR><LF>
	This message must always be transmitted after each escape programming string (refer to paragraph 3.2). If the programming is correct, the device confirms with the first reply message. If programming contents are wrong (i.e. a typing error in the programming string) or due to a transmission error, Matrix replies with the second error message.		
2	Exit Programming Mode and Data Storage	<ESC> I A ! <ESC> I A <space>	<ESC> K <CR><LF> <ESC> W 1 <CR><LF>
	This command must always be transmitted to exit from programming mode. It defines whether the configuration will be saved in the temporary (RAM) or permanent (FLASH) memory (refer to paragraph 3.4). If the programming is correct, the device updates the configuration and confirms with the first reply message. If programming contents are wrong (i.e. a typing error in the file) or due to a transmission error, Matrix replies with the second error message and programming data will not be updated in this case.		
3	Exit Host Mode	<ESC> [A	<ESC> X <CR><LF>
	This command must always be transmitted to end the programming session. On exit from Host Mode, the device is initialized with the new programming already saved in the temporary and/or permanent memory.		
4	End of Single Parameter Get Sequence	<ESC> I D #	<ESC> CH1 CH2 DATA <ESC> I A # <ESC> W 1 <CR><LF>
	This message must always be transmitted after each escape get string (refer to par. 3.3). If the get string is correct, the device replies with the current value of the parameter (refer to par. 3.3). If the get contents are wrong (i.e. a typing error in the programming string) or due to a transmission error, Matrix replies with the second error message.		

2.3 READER INFORMATION

	DESCRIPTION	HOST COMMAND	REPLY MESSAGE
1	Get Reader Model	<ESC> [E	Reader Model
	After entering this command during the <u>programming session</u> , the reader responds with a string containing its model number (e.g. 600-010).		
2	Get Software Version	<ESC> [F	Software Version
	After entering this command during the <u>programming session</u> , the reader responds with a string containing the factory loaded application program release (e.g. Standard Application Program for Matrix Family release 5.60).		
3	Get Reader Name	<ESC> [G	Reader Name
	After entering this command during the <u>programming session</u> , the reader responds with a string containing the <i>Reader Name</i> parameter value (refer to paragraph 4.21 for further details).		

2.4 PROGRAMMABLE BUTTON FUNCTIONS

	DESCRIPTION	HOST COMMAND	REPLY MESSAGE
1	Button Function 1	<ESC> 0 <ESC> I C #	<ESC> K <CR><LF> <ESC> W 1 <CR><LF>
	After entering this command during the <u>programming session</u> , the reader starts the function associated with the F1 button position. Entering the same command again will cause the reader to exit from the procedure. If the programming command is correct, the device confirms with the first reply message. If programming command is wrong (i.e. a typing error in the programming string) or due to a transmission error, Matrix replies with the second error message.		
2	Button Function 2	<ESC> 1 <ESC> I C #	<ESC> K <CR><LF> <ESC> W 1 <CR><LF>
	After entering this command during the <u>programming session</u> , the reader starts the function associated with the F2 button position. Entering the same command again will cause the reader to exit from the procedure. If the programming command is correct, the device confirms with the first reply message. If programming command is wrong (i.e. a typing error in the programming string) or due to a transmission error, Matrix replies with the second error message.		
3	Button Function 3	<ESC> 2 <ESC> I C #	<ESC> K <CR><LF> <ESC> W 1 <CR><LF>
	After entering this command during the <u>programming session</u> , the reader starts the function associated with the F3 button position. Entering the same command again will cause the reader to exit from the procedure. If the programming command is correct, the device confirms with the first reply message. If programming command is wrong (i.e. a typing error in the programming string) or due to a transmission error, Matrix replies with the second error message.		

	DESCRIPTION	HOST COMMAND	REPLY MESSAGE
4	Button Function 4	<ESC> 3 <ESC> I C #	<ESC> K <CR><LF> <ESC> W 1 <CR><LF>
	<p>After entering this command during the <u>programming session</u>, the reader starts the function associated with the F4 button position. Entering the same command again will cause the reader to exit from the procedure.</p> <p>If the programming command is correct, the device confirms with the first reply message. If programming command is wrong (i.e. a typing error in the programming string) or due to a transmission error, Matrix replies with the second error message.</p>		

2.5 OTHER FUNCTIONS

	DESCRIPTION	HOST COMMAND	REPLY MESSAGE
1	Disable All Symbologies	<ESC> 4 <ESC> I C #	<ESC> K <CR><LF> <ESC> W 1 <CR><LF>
	<p>After entering this command during the <u>programming session</u>, the reader disables all the symbologies in permanent memory.</p> <p>If the programming command is correct, the device confirms with the first reply message. If programming command is wrong (i.e. a typing error in the programming string) or due to a transmission error, Matrix replies with the second error message.</p>		
2	Restore Default	<ESC> 5 <ESC> I C #	<ESC> K <CR><LF> <ESC> W 1 <CR><LF>
	<p>After entering this command during the <u>programming session</u>, the reader restores the factory default parameters in permanent memory.</p> <p>If the programming command is correct, the device confirms with the first reply message. If programming command is wrong (i.e. a typing error in the programming string) or due to a transmission error, Matrix replies with the second error message.</p>		

3 PROGRAMMING STRINGS

3.1 DEFINITIONS

Common definitions for each parameter are:

Depth (parameter depth)

Parameter depth indicates if the parameter is made up of a vector of values or a single value (e.g. *Gain* parameter has depth > 1 since we have one *Gain* value for each recipe allowed; *Operating Mode* parameter has depth =1).

Depth must be specified when preparing the escape programming string.

Example: *Image Acquisition Setting #3* enable/disable.

Label:	Image Acquisition Setting
Escape Sequence	<ESC> a #n [selection]

Type (parameter type)

Parameter type is essential in order to decide the features of the serial command used to set its new value. Types are:

Type 0:	Integer (numeric)
Type 1:	Enumerative
Type 2:	String
Type 3:	Bit Field
Type 4:	At Least One

Label

Information available in the Parameters window of the VisiSet™ configuration tool.

The other definitions change according to the parameter type.

Integer (Type = 0)

Range

Minimum and maximum values allowed for the parameter.

Default

Default value (integer).

Example: *Reading Phase Timeout* parameter

Type:	0
Label:	Reading Phase Timeout
Range:	35, 60000
Default:	1000

Enumerative (Type = 1)

Item List

List of the values allowed for the parameter.

Selection

Maximum number of values selectable at the same time (normally equal to 1).

Default

Default entry (i.e. 0 = first entry of the list, 1 = second entry of the list).

Example: *Operating Mode* parameter.

Type: 1
Label: Operating Mode
Item List: *One Shot, Continuous, Phase Mode*
Selection: 1
Default: 0 (Entry 0 → One Shot)

String (Type = 2)

Length

Minimum and maximum number of characters allowed for this parameter.

Default

Default value (String).

Example: *Link Failure String* parameter.

Type: 2
Label: Link Failure String
Length: 0, 32
Default: Empty string

Bit Field (Type = 3)

Item List

List of the allowed values of the parameter.

Selection

Maximum number of values selectable at the same time (normally the number of items available in the list - 1).

Default

Default entries (i.e. 0 = first entry of the list (not considered), 2^0 = second entry of the list, 2^1 = third entry of the list).

Default value is given by the sum of the selected entries of the Item List.

Example: OUTPUT 1 *Activation Events* parameter

Type: 3
 Label: Activation Events
 Item List *None, Complete Read, Partial Read, No Read, Acquisition Trigger, Phase ON, Phase OFF, Run Mode, Host Control Mode, ISO-IEC Symbol Contrast, ISO-IEC Print Growth, ISO-IEC/AIM DPM Axial Non Uniformity, ISO-IEC/AIM DPM Unused ECC, ISO-IEC Modulation, ISO-IEC Min Edge Contrast, ISO-IEC Decodability, ISO-IEC/AIM DPM Fixed Pattern Damage, ISO-IEC/AIM DPM Grid Non Uniformity, ISO-IEC/AIM DPM Minimum Reflectance, ISO-IEC Defects, ISO-IEC/AIM DPM Decode, AIM DPM Cell Contrast, AIM DPM Cell Modulation, AS9132 Dot Size/Cell Fill, AS9132 Dot Center Offset, AS9132 Dot Ovality, AS9132 Quiet Zone, AS9132 Angle Of Distortion, AS9132 Symbol Contrast.*
 Selection: 19
 Default: 6 ($2^1 + 2^2 \rightarrow$ *Partial-Read + No-Read*)

Caution: The first entry (*None*) can only be selected by setting the parameter value to 0.

Example:

Run Mode: entry 7 (-1) \rightarrow value = $2^6 = 64$.
Partial Read + No Read: entry 2 (-1) + entry 3 (-1) \rightarrow value = $2^1 + 2^2 = 6$.
ISO-IEC Modulation: entry 13 (-1) \rightarrow value = $2^{12} = 4096$

At Least One (Type = 4)

Item List

List of the allowed values of the parameter

Selection

Maximum number of values selectable at the same time (normally the number of items available in the list).

Default

Default entries (2^0 = first entry of the list, 2^1 = second entry of the list, 2^2 = third entry of the list). The default value is given by the sum of the selected entries of the list.

Example: *Reading Phase ON* parameter

Type: 4
 Label: Reading Phase ON
 Item List *External Trigger Leading Edge, External Trigger Trailing Edge, Main Port String, Auxiliary Port String, Input 2 Leading Edge, Input 2 Trailing Edge, Ethernet String, Fieldbus String, Fieldbus Input Leading Edge, Fieldbus Input Trailing Edge*
 Selection: 9
 Default: 1 ($2^0 \rightarrow$ *External Trigger Leading Edge*)

Caution: This parameter type cannot be set to 0.

Example:

External Trigger Leading Edge: Entry 0 → Value = $2^0 = 1$.

External Trigger Trailing Edge: Entry 1 → Value = $2^1 = 2$.

Main Port String + Auxiliary Port String: Entry 2 + Entry 3 → Value = $2^2 + 2^3 = 12$.

3.2 HOW TO SEND A SINGLE PARAMETER TO THE READER

The Matrix device single parameter programming string must have the following format:

Parameter Depth = 1

<ESC> CHR1 CHR2 DATA

Where:

- **CHR1:** Character identifying the category of the parameter to program.
- **CHR2:** Character identifying the Function in the category.
- **DATA:** Character or string indicating the assigned parameter Value.

Parameter Depth > 1

<ESC> CHR1 CHR2 [CHR3 <FE_H> <FD_H>] DATA

Where:

- **CHR1:** Character identifying the Function of the parameter to program.
- **CHR2,CHR3:** Character indicating the Depth of the parameter to program.
- **<FE_H>, <FD_H>** Special characters used to indicate parameter **Depth > 9**.
- **DATA:** Character or string indicating the assigned parameter Value.

The following command must be transmitted after sending each programming string:

<ESC> I A #

If the programming is correct, the device confirms with the following message:

<ESC> K <CR><LF>

If programming contents are wrong (i.e. a typing error in the file) or due to a transmission error, the device replies with the following message and programming data will not be updated in this case:

<ESC> W 1 <CR><LF>

After transmitting the proper reply message, the device then waits for one or more programming strings.

3.3 HOW TO GET A SINGLE PARAMETER FROM THE READER

The Matrix device single parameter get string must have the following format:

Parameter Depth = 1

<ESC> CHR1 CHR2

Where:

- **CHR1:** Character identifying the category of the parameter to get.
- **CHR2:** Character identifying the Function in the category.

Parameter Depth > 1

<ESC> CHR1 CHR2 [CHR3 <FE_H> <FD_H>]

Where:

- **CHR1:** Character identifying the Function of the parameter to program.
- **CHR2,CHR3:** Character indicating the Depth of the parameter to program.
- **<FE_H>,<FD_H>** Special characters used to indicate parameter **Depth > 9**.

The following command must be transmitted after sending each get command string:

<ESC> I D #

If the sequence is correct, the device replies with the programming string for the current value of the parameter:

Parameter Depth = 1

<ESC> CHR1 CHR2 DATA <ESC> I A #

Where:

- **CHR1:** Character identifying the category of the parameter to get.
- **CHR2:** Character identifying the Function in the category.
- **DATA:** Character or string indicating the current parameter Value.

Parameter Depth > 1

<ESC> CHR1 CHR2 [CHR3 <FE_H> <FD_H>] DATA <ESC> I A #

Where:

- **CHR1:** Character identifying the Function of the parameter to get.
- **CHR2,CHR3:** Character indicating the Depth of the parameter to get.
- **<FE_H>,<FD_H>** Special characters used to indicate parameter **Depth > 9**.
- **DATA:** Character or string indicating the current parameter Value.

If sequence contents are wrong (i.e. a typing error in the file) or due to a transmission error, the device replies with the following message:

<ESC> W 1 <CR><LF>

After transmitting the proper reply message, the device then waits for one or more get strings or one or more programming strings or the exit from host mode command.

3.4 DATA STORAGE COMMANDS

The Matrix device data storage programming command must have the following format:

<ESC> I A MODE

Where:

- **MODE:** Data storage mode. The possible values are:
 - ! = Storage in temporary (volatile) memory only.
 - Space** = Storage in temporary and permanent memory.

This command must always be transmitted to exit from programming mode.

If the programming is correct, the device updates the configuration and confirms with the following message:

<ESC> K <CR><LF>

If programming contents are wrong (i.e. a typing error in the file) or due to a transmission error, the device replies with the following message and programming data will not be updated in this case:

<ESC> W 1 <CR><LF>

After transmitting the proper reply message, the device then waits for new programming session or exit from host mode.

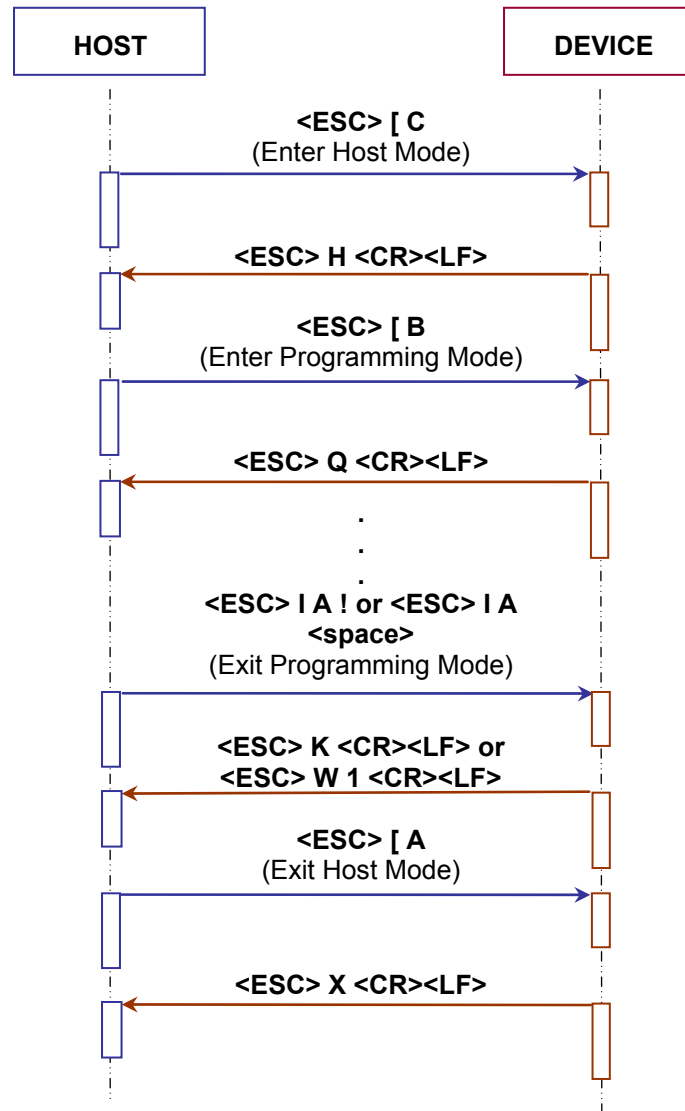

Figure 1 – Connection to Device and Disconnection from Device

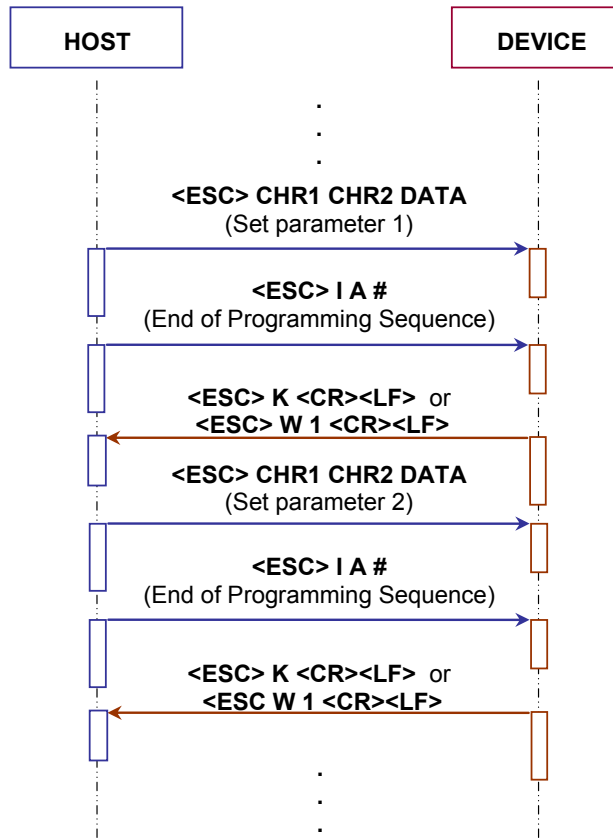

Figure 2 – Two-Parameter Programming Session

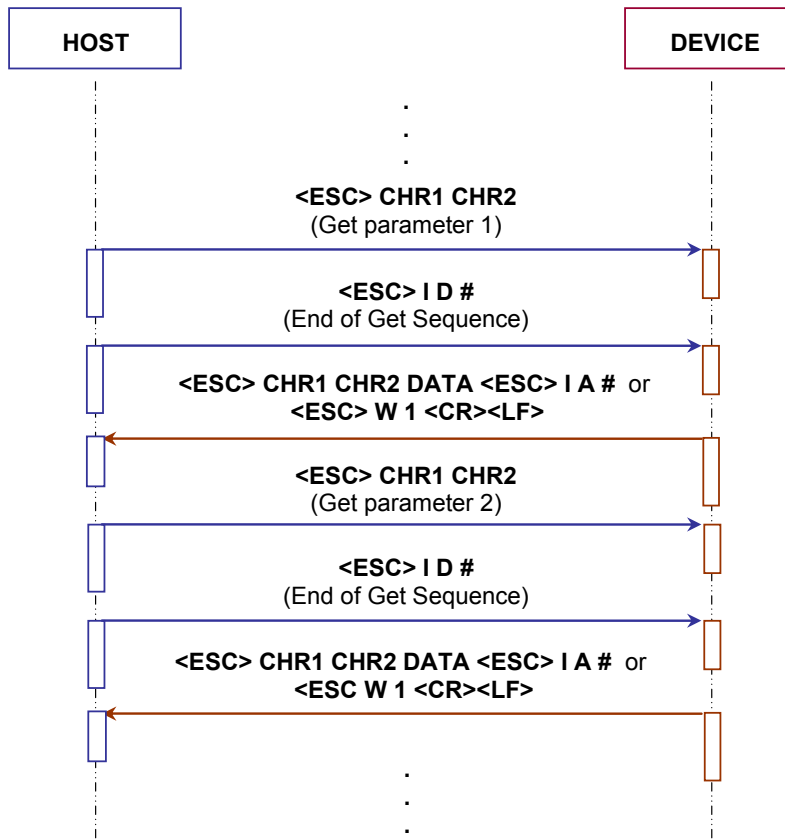

Figure 3 – Two-Parameter Get Session

3.5 HOW TO PROGRAM AN ID-NET™ SLAVE READER

An ID-NET™ (Multidata) Slave #N can be configured through the Master (Multidata) device "encapsulating" the same Host Mode Programming Commands and Programming Strings as a Standalone reader, (see par. 3.2), in a special command with the following format:

<ESC> (<B0_H> ADDR STRING) <ESC>

Where:

- **ADDR:** Device Address
- **STRING:** Programming Command/String To Send (Length: 1 to 252)

ADDR is a character indicating address of the device in an ID-NET™ Master/Slave reading system layout:

ADDR = <30_H> + <Device Address> where:

- Device Address = 0:** Standalone device or Master Multidata ID-NET™ device
- Device Address = 1 to 31:** Slave Multidata ID-NET™ device

This means:

- ADDR = <30_H>:** Standalone device or Master Multidata ID-NET™ device
- ADDR = <31_H> to <4F_H>:** Slave Multidata ID-NET™ device

The following command must be transmitted after sending each programming string:

<ESC> (<B0_H> ADDR <ESC> I A #) <ESC>

If the programming is correct, the Slave device sends the following message to the Master:

<ESC> K <CR><LF>

If programming contents are wrong (i.e. a typing error in the file) or due to a transmission error, the Slave device replies with the following message and programming data will not be updated in this case:

<ESC> W 1 <CR><LF>

After transmitting the proper reply message, the Slave device then waits for one or more programming strings or the exit from host mode command.

3.6 HOW TO GET A SINGLE PARAMETER FROM AN ID-NET™ SLAVE READER

The current value of a single parameter of an ID-NET™ (Multidata) Slave #N can be obtained through the Master (Multidata) device "encapsulating" the same Host Mode Get Commands and Get Strings as a Standalone reader, (see par. 3.3), in a special command with the following format:

<ESC> (<B0_H> ADDR STRING) <ESC>

Where:

- **ADDR:** Device Address
- **STRING:** Get Command/String To Send (Length: 1 to 252)

ADDR is a character indicating address of the device in an ID-NET™ Master/Slave reading system layout:

ADDR = <30_H> + <Device Address> where:

- Device Address = 0:** Standalone device or Master Multidata ID-NET™ device
- Device Address = 1 to 31:** Slave Multidata ID-NET™ device

This means:

- ADDR = <30_H>:** Standalone device or Master Multidata ID-NET™ device
- ADDR = <31_H> to <4F_H>:** Slave Multidata ID-NET™ device

The following command must be transmitted after sending each get command string:

<ESC> (<B0_H> ADDR <ESC> I D #) <ESC>

If the sequence is correct, the device replies with the programming string for the current value of the parameter:

Parameter Depth = 1

<ESC> CHR1 CHR2 DATA <ESC> I A #

Where:

- **CHR1:** Character identifying the category of the parameter to get.
- **CHR2:** Character identifying the Function in the category.
- **DATA:** Character or string indicating the current parameter Value.

Parameter Depth > 1

<ESC> CHR1 CHR2 [CHR3 <FE_H> <FD_H>] DATA <ESC> | A #

Where:

- **CHR1:** Character identifying the Function of the parameter to get.
- **CHR2,CHR3:** Character indicating the Depth of the parameter to get.
- **<FE_H>,<FD_H>** Special characters used to indicate parameter **Depth > 9**.
- **DATA:** Character or string indicating the current parameter Value.

If sequence contents are wrong (i.e. a typing error in the file) or due to a transmission error, the Slave device replies with the following message:

<ESC> W 1 <CR><LF>

After transmitting the proper reply message, the Slave device then waits for one or more get strings or one or more programming strings or the exit from host mode command.

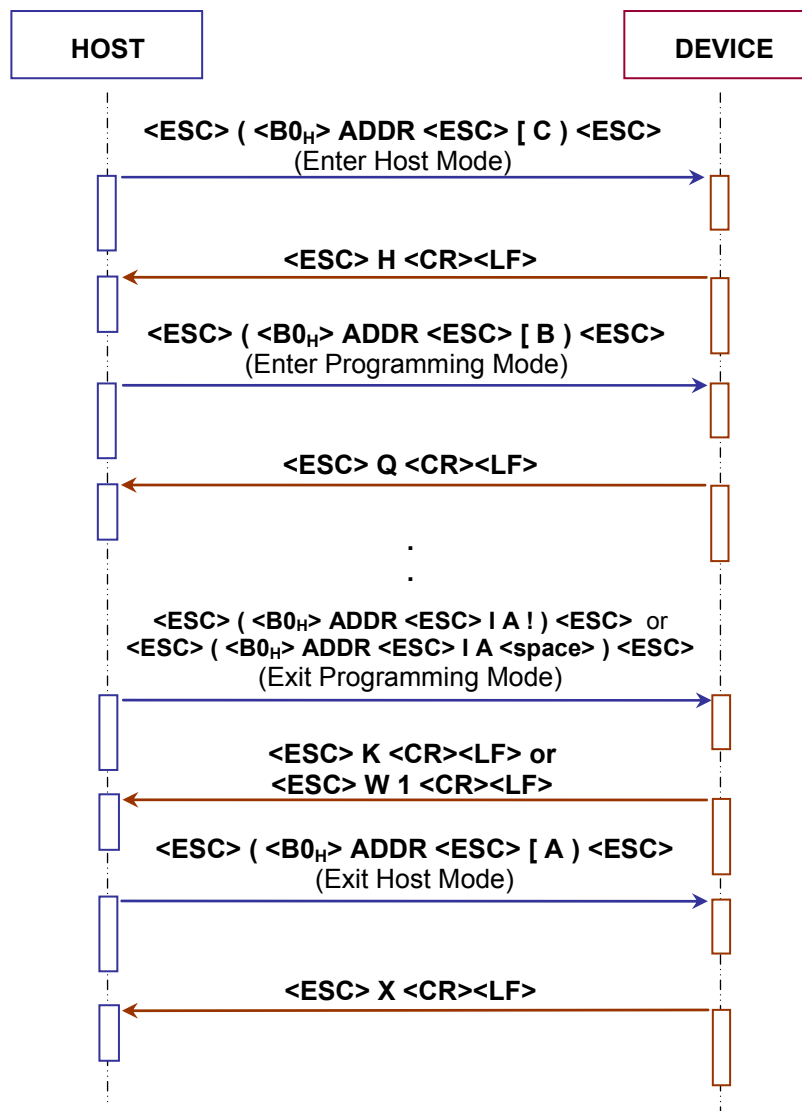

Figure 4 – Connection to Slave #N and Disconnection from Slave #N Device

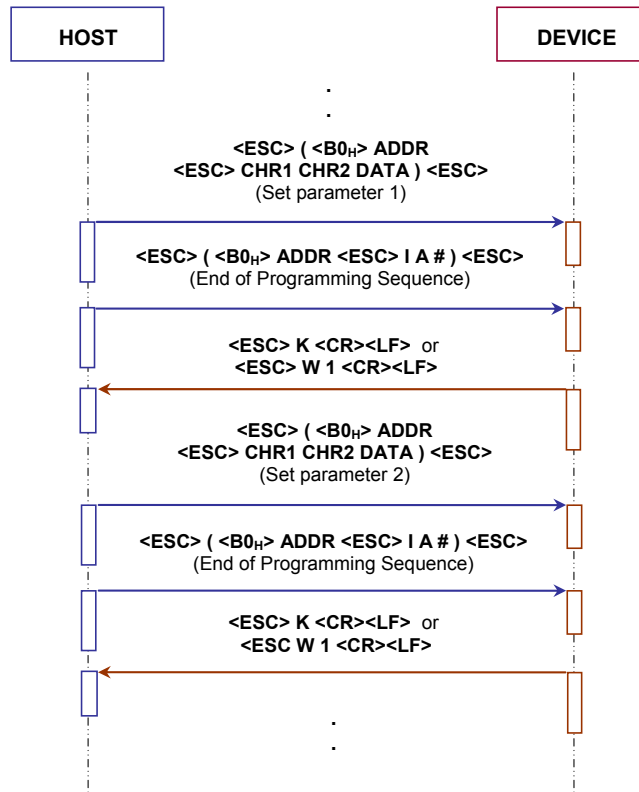

Figure 5 – Slave #N Two-Parameter Programming Session

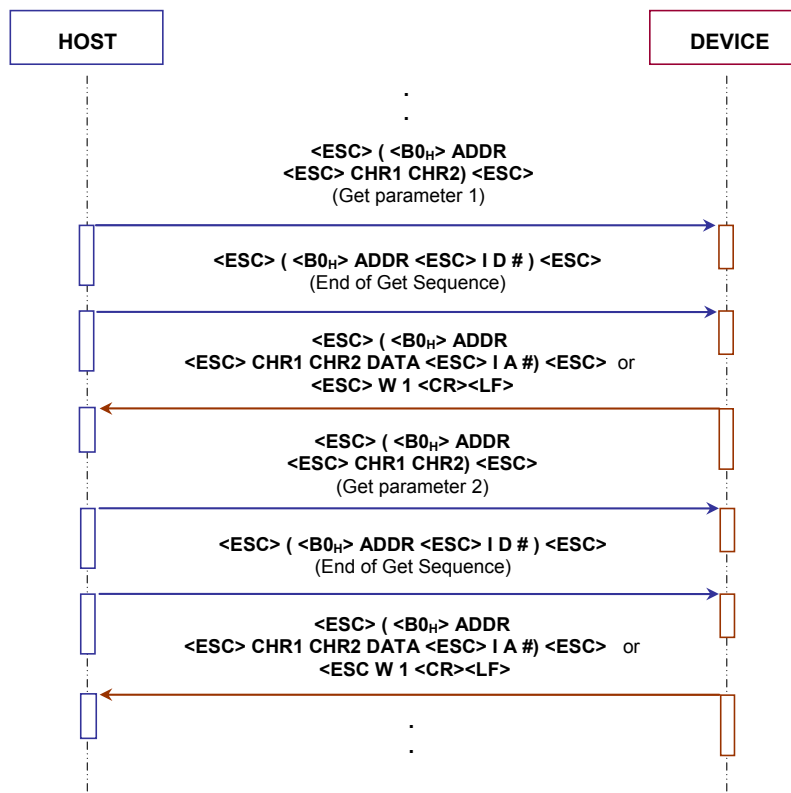

Figure 6 – Slave #N Two-Parameter Get Session

3.7 EXAMPLES

- 1 -

Set *Reading Phase Timeout* parameter in OPERATING MODE folder:

Type: 0
Range: 35 to 60000
Data: 15000

The programming string is:

<ESC> A E 15000 <ESC> I A #

- 2 -

Set *Gain* parameter in IMAGE ACQUISITION SETTING #2 folder:

Type: 0
Range: 0 to 800
Data: 300

The programming string is:

<ESC> f 2 300 <ESC> I A #

- 3 -

Set Data Matrix ECC 200 *Status* parameter:

Type: 1
Item List: *Enabled, Disabled*
Data: 0 (disable decoding of this symbology)

The programming string is:

<ESC> G A 0 <ESC> I A #

- 4 -

Set *Trigger* parameter in ACQUISITION TRIGGER DELAY #10 folder:

Type: 1
Item List: *Disable, Enable*
Data: 1 (enable delayed trigger)

The programming string is:

<ESC> n 10 <FE_H> <FD_H> 1 <ESC> I A #

- 5 -

Set *Link Failure String* parameter in READING SYSTEM LAYOUT folder:

Type: 2
 Length: 0, 32
 Value: LINK_FAILURE

The programming string is:

<ESC> A T LINK_FAILURE <ESC> I A #

- 6 -

Set *Terminator String* parameter in COMMUNICATION - MAIN PORT folder:

Type: 2
 Length: 0 to 128
 Value: CR LF non-printable characters

The programming string is:

<ESC> B L <CR><LF> <ESC> I A #

or

<ESC> B L <13><10> <ESC> I A #

or

<ESC> B L <0D_H><0A_H> <ESC> I A #

- 7 -

Set OUTPUT 2 *Activation Events* parameter in DIGITAL I/O folder:

Type: 3
 Item List: *None, Complete Read, Partial Read, No Read, Acquisition Trigger, Phase ON, Phase OFF, Run Mode, Host Control Mode, ISO-IEC Symbol Contrast, ISO-IEC Print Growth, ISO-IEC/AIM DPM Axial Non Uniformity, ISO-IEC/AIM DPM Unused ECC, ISO-IEC Modulation, ISO-IEC Min Edge Contrast, ISO-IEC Decodability, ISO-IEC/AIM DPM Fixed Pattern Damage, ISO-IEC/AIM DPM Grid Non Uniformity, ISO-IEC/AIM DPM Minimum Reflectance, ISO-IEC Defects, ISO-IEC/AIM DPM Decode, AIM DPM Cell Contrast, AIM DPM Cell Modulation, AS9132 Dot Size/Cell Fill, AS9132 Dot Center Offset, AS9132 Dot Ovality, AS9132 Quiet Zone, AS9132 Angle Of Distortion, AS9132 Symbol Contrast.*
 Value: $2^5 + 2^6$ (Phase-OFF + Enter In Run Mode) = 96

The programming string is:

<ESC> O J 96 <ESC> I A #

- 8 -

Get current value *Link Failure String* parameter in READING SYSTEM LAYOUT folder:

Type: 2
Length: 0, 32
Current LINK_FAILURE
Value:

The get string is:

<ESC> A T <ESC> I D #

The reader answer is:

<ESC> A T LINK_FAILURE<ESC> I A #

- 9 -

Get current value *Gain* parameter in IMAGE ACQUISITION SETTING #2 folder:

Type: 0
Range: 0 to 800
Current 300
Data:

The get string is:

<ESC> f 2 <ESC> I D #

The reader answer is:

<ESC> f 2 300<ESC> I A #

4 MATRIX 210™ PARAMETERS LIST

4.1 OPERATING MODE

25 PIN CONNECTOR MODELS ETHERNET MODELS

PARAMETER	TYPE	SEL	STRING	DATA
OPERATING MODES				
Operating Mode	1	1	<ESC> A A	0 = One Shot 1 = Continuous 2 = Phase Mode
Reading Phase ON	4	9	<ESC> A B	1 = Ext. Trig. Lead. Edge 2 = Ext. Trig. Trailing Edge 4 = Main Port String 8 = Auxiliary Port String 16 = Input 2 Leading Edge 32 = Input 2 Trailing Edge 64 = Ethernet String 128 = Ethernet IP Input Leading Edge 256 = Ethernet IP Input Trailing Edge 512 = Fieldbus String 1024 = Fieldbus Input Leading Edge 2048 = Fieldbus Input Trailing Edge 4096 = ID-NET String
Acquisition Trigger (Phase Mode)	4	10	<ESC> A C	1 = Continuous 2 = Multi-Delay 4 = Periodic 8 = Input 2 Leading Edge 16 = Input 2 Trailing Edge 32 = Main Port String 64 = Auxiliary Port String 128 = Ext. Trig. Leading Edge 256 = Ext. Trig. Trailing Edge 512 = Ethernet String 1024 = Ethernet IP Trigger Leading Edge 2048 = Ethernet IP Trigger Trailing Edge 4096 = Fieldbus String 8192 = Fieldbus Input Leading Edge 16384 = Fieldbus Input Trailing Edge 32768 = ID-NET String
Acquisition Trigger Status	1	1	<ESC> A P	0 = Always Enabled 1 = Enabled When Input 2 Open 2 = Enabled When Input 2 Closed
Acquisition Trigger Period (ms) (Phase Mode)	0		<ESC> A G	Range: 17 to 60000

PARAMETER	TYPE	SEL	STRING	DATA
Reading Phase OFF	4	11	<ESC> A D	1 = Ext. Trig. Leading Edge 2 = Ext. Trig. Trailing Edge 4 = Main Port String 8 = Auxiliary Port String 16 = Input 2 Leading Edge 32 = Input 2 Trailing Edge 64 = Timeout 128 = Complete Read 256 = Ethernet String 512 = Ethernet IP Input Leading Edge 1024 = Ethernet IP Input Trailing Edge 2048 = Fieldbus String 4096 = Fieldbus Input Leading Edge 8192 = Fieldbus Input Trailing Edge 16834 = ID-NET String
Reading Phase Timeout (ms)	0		<ESC> A E	Range: 17 to 60000
Timeout Counting From	1	1	<ESC> A N	0 = Reading Phase ON 1 = Reading Phase OFF
Acquisition Trigger (One Shot)	4	7	<ESC> A F	1 = Ext. Trig. Leading Edge 2 = Ext. Trig. Trailing Edge 4 = Main Port String 8 = Auxiliary Port String 16 = Ethernet String 32 = Ethernet IP Input Leading Edge 64 = Ethernet IP Input Trailing Edge 128 = Fieldbus String 256 = Fieldbus Input Leading Edge 512 = Fieldbus Input Trailing Edge 1024 = ID-NET String
First Acquisition Setting Used	1	1	<ESC> A H	0 = First Enabled 1 = Last Successful
Image Acquisition Buffer Size	0		<ESC> A L	Range: 2 to 300
Code Filter Depth	0		<ESC> A I	Range: 0 to 5
Code Filter Selection	1	1	<ESC> A N	0 = Acquisition Counter Threshold 1 = Timeout Threshold
Complete Read Threshold	0		<ESC> A J	Range: 0 to 100000
No Read Threshold	0		<ESC> A K	Range: 0 to 100000
Timeout Threshold (sec)	0		<ESC> A O	Range: 0 to 300 (0 = Disabled)
ACQUISITION TRIGGER DELAY (DEPTH: n = 1 to 10)				
Status #n	1	1	<ESC> n #n	0 = Disabled 1 = Enabled
Delay Time #n (x100 μs)	0		<ESC> o #n	Range: 0 to 100000

 **NOTE** Special characters <FE_H> and <FD_H> must be added after #n in the programming string to indicate parameter **Depth** > 9. Refer to paragraph 3.2 for further details.

USB CONNECTOR MODELS

PARAMETER	TYPE	SEL	STRING	DATA
OPERATING MODES				
Operating Mode	1	1	<ESC> A A	0 = One Shot 1 = Continuous 2 = Phase Mode
Reading Phase ON	4	1	<ESC> A B	1 = Main Port String
Acquisition Trigger (Phase Mode)	4		<ESC> A C	1 = Continuous 2 = Multi-Delay 4 = Periodic 8 = Main Port String
Acquisition Trigger Period (ms) (Phase Mode)	0		<ESC> A G	Range: 17 to 60000
Reading Phase OFF	4	1	<ESC> A D	1 = Main Port String 2 = Timeout 4 = Complete Read
Reading Phase Timeout (ms)	0		<ESC> A E	Range: 17 to 60000
Timeout Counting From	1	1	<ESC> A N	0 = Reading Phase ON 1 = Reading Phase OFF
Acquisition Trigger (One Shot)	4	1	<ESC> A F	1 = Main Port String
First Acquisition Setting Used	1	1	<ESC> A H	0 = First Enabled 1 = Last Successful
Image Acquisition Buffer Size	0		<ESC> A L	Range: 2 to 300
Code Filter Depth	0		<ESC> A I	Range: 0 to 5
Code Filter Selection	1	1	<ESC> A W	0 = Acquisition Counter Threshold 1 = Timeout Threshold
Complete Read Threshold	0		<ESC> A J	Range: 0 to 100000
No Read Threshold	0		<ESC> A K	Range: 0 to 100000
Timeout Threshold (sec)	0		<ESC> A O	Range: 0 to 300 (0 = Disabled)
ACQUISITION TRIGGER DELAY (DEPTH: n = 1 to 10)				
Status #n	1	1	<ESC> n #n	0 = Disabled 1 = Enabled
Delay Time #n (x100 μs)	0		<ESC> o #n	Range: 0 to 100000

**NOTE**

Special characters <FE_H> and <FD_H> must be added after #n in the programming string to indicate parameter **Depth** > 9. Refer to paragraph 3.2 for further details.

4.2 CALIBRATION

PARAMETER	TYPE	SEL	STRING	DATA
IMAGE ACQUISITION SETTING (DEPTH: n = 1 to 10)				
Status #n	1	1	<ESC> a #n	0 = Disabled 1 = Enabled
Self Tuning #n	1	1	<ESC> G #n	0 = Disabled 1 = Enabled
Self Tuning Mode #n	1	1	<ESC> H #n	0 = Gain Only 1 = Exposure Time Only 2 = Exposure Time And Gain
Self Tuning Timeout (ms) #n	0	0	<ESC> I #n	Range: 1 to 10000 (0 = Disabled)
Internal Lighting Mode #n	1	1	<ESC> j #n	0 = Disabled 1 = Always On 2 = Very High-Power Strobed 3 = High-Power Strobed 4 = Medium-Power Strobed
Exposure Time #n Very High-Power Strobed (x 10 μs)	0		<ESC> b #n	Range: 1 to 60
Exposure Time #n High-Power Strobed (x 100 μs)	0		<ESC> c #n	Range: 1 to 50
Exposure Time #n Medium-Power Strobed (x 1 ms)	0		<ESC> d #n	Range: 1 to 26
Exposure Time #n Disabled, Always On (x 10 μs)	0		<ESC> e #n	Range: 1 to 2600
Gain #n	0		<ESC> f #n	Range: 1 to 40
Gain Increasing #n	1	1	<ESC> h #n	0 = x1 1 = x2 2 = x3 3 = x4 4 = x5 5 = x6 6 = x7 7 = x8 8 = x9 9 = x10
Image Polarity Inversion #n	1	1	<ESC> i #n	0 = Disabled 1 = Enabled
Region Of Interest:: Top #n	0		<ESC> A #n	Range: 0 to 479
Region Of Interest:: Bottom #n	0		<ESC> B #n	Range: 0 to 479
Region Of Interest:: Left #n	0		<ESC> C #n	Range: 0 to 751
Region Of Interest:: Right #n	0		<ESC> D #n	Range: 0 to 751
Output 1 External Lighting Mode #n	1	1	<ESC> k #n	0 = Disabled 1 = Always On 2 = Triggered
Output 2 External Lighting Mode #n	1	1	<ESC> E #n	0 = Disabled 1 = Always On 2 = Triggered

PARAMETER	TYPE	SEL	STRING	DATA
Image Rescaling	1	1	<ESC> k l #n	0 = None 1 = 2 x 2 2 = 4 x 4
Image Filter #n	1	1	<ESC> l #n	0 = None 1 = Erode 2 = Dilate 3 = Open 4 = Close 5 = Contrast Stretching 6 = Histogram Equalization 7 = Smoothing 8 = Sharpening 9 = Deblurring 10 = Black Enhancement 11 = White Enhancement
Image Filter Dimensions	1	1	<ESC> m #n	0 = 3x3 1 = 5x5 2 = 7x7

**NOTE**

Special characters <FE_H> and <FD_H> must be added after #n in the programming string to indicate parameter **Depth** > 9. Refer to paragraph 3.2 for further details.

4.3 COMMUNICATION

25 PIN CONNECTOR MODELS ETHERNET MODELS

PARAMETER	TYPE	SEL	STRING	DATA
MAIN PORT				
Data TX	1	1	<ESC> B A	0 = Disabled 1 = Enabled
Serial Interface Type	1	1	<ESC> B B	0 = RS232 1 = RS485
Communication Protocol	1	1	<ESC> B C	0 = None 1 = MUX32 2 = Siemens 3964 3 = Siemens RK512
Multidrop Address	0		<ESC> B D	Range: 0 to 31
Baud Rate	1	1	<ESC> B E	0 = 2400 1 = 4800 2 = 9600 3 = 19200 4 = 38400 5 = 57600 6 = 115200

PARAMETER	TYPE	SEL	STRING	DATA
Baud Rate Multidrop bus	1	1	<ESC> B F	0 = 2400 1 = 4800 2 = 9600 3 = 19200 4 = 38400 5 = 57600 6 = 115200
Parity	1	1	<ESC> B G	0 = None 1 = Odd 2 = Even
Data Bits	1	1	<ESC> B H	0 = 7 1 = 8
Stop Bits	1	1	<ESC> B I	0 = 1 1 = 2
Handshake	1	1	<ESC> B J	0 = None 1 = XON/XOFF 2 = RTS/CTS
Header String	2		<ESC> B K	Length: 0 to 128
Terminator String	2		<ESC> B L	Length: 0 to 128
Reading Phase ON String	2		<ESC> B M	Length: 1 to 128
Acquisition Trigger String	2		<ESC> B N	Length: 1 to 128
Reading Phase OFF String	2		<ESC> B O	Length: 1 to 128
SIEMENS PROTOCOL				
Protocol Checksum	1	1	ESC C A	0 = Disabled 1 = Enabled
Protocol Priority	1	1	<ESC> C B	0 = Low 1 = High
Header Character 5	2		<ESC> C D	Length: 0 to 1
Header Character 6	2		<ESC> C E	Length: 0 to 1
Header Character 9	2		<ESC> C F	Length: 0 to 1
Header Character 10	2		<ESC> C G	Length: 0 to 1
Fill Character	1		<ESC> C H	Length: 0 to 1
Fill Position	1	1	<ESC> C I	0 = Before Data 1 = After Data
AUXILIARY PORT				
Communication Mode	1	1	<ESC> D A	0 = Standard 1 = Local Echo 2 = Pass-Through
Search for Backup Memory at Startup	1	1	<ESC> D L	0 = Disabled 1 = Enabled
Baud Rate	1	1	<ESC> D B	0 = 2400 1 = 4800 2 = 9600 3 = 19200 4 = 38400 5 = 57600 6 = 115200
Parity	1	1	<ESC> D C	0 = None 1 = Odd 2 = Even
Data Bits	1	1	<ESC> D D	0 = 7 1 = 8

PARAMETER	TYPE	SEL	STRING	DATA
Stop Bits	1	1	<ESC> D E	0 = 1 1 = 2
Handshake	1	1	<ESC> D F	0 = None 1 = XON/XOFF
Header String	2		<ESC> D G	Length: 0 to 128
Terminator String	2		<ESC> D H	Length: 0 to 128
Reading Phase ON String	2		<ESC> D I	Length: 0 to 128
Acquisition Trigger String	2		<ESC> D J	Length: 0 to 128
Reading Phase OFF String	2		<ESC> D K	Length: 0 to 128

USB CONNECTOR MODELS

PARAMETER	TYPE	SEL	STRING	DATA
MAIN PORT				
Data TX	1	1	<ESC> B A	0 = Disabled 1 = Enabled
Baud Rate	1	1	<ESC> B E	0 = 115200 1 = 230400 2 = 460800 3 = 921600
Handshake	1	1	<ESC> B J	0 = None 1 = XON/XOFF
Header String	2		<ESC> B K	Length: 0 to 128
Terminator String	2		<ESC> B L	Length: 0 to 128
Reading Phase ON String	2		<ESC> B M	Length: 1 to 128
Acquisition Trigger String	2		<ESC> B N	Length: 1 to 128
Reading Phase OFF String	2		<ESC> B O	Length: 1 to 128

4.4 ETHERNET

ETHERNET MODELS

PARAMETER	TYPE	SEL	STRING	DATA
ETHERNET SYSTEM				
Status	1	1	<ESC> E A	0 = Disabled 1 = Enabled
First Linkup Ignored	1	1	<ESC> E -	0 = Disabled 1 = Enabled
DHCP Client	1	1	<ESC> E C	0 = Disabled 1 = Enabled
IP Address	2		<ESC> E D	Length: 0 to 15
Subnet Mask	2		<ESC> E E	Length: 0 to 15
Gateway Address	2		<ESC> E F	Length: 0 to 15
DNS1 Address	2		<ESC> E G	Length: 0 to 15

PARAMETER	TYPE	SEL	STRING	DATA
DATA SOCKET				
Status	1	1	<ESC> E I	0 = Disabled 1 = Enabled
Header String	2		<ESC> E J	Length: 0 to 128
Terminator String	2		<ESC> E K	Length: 0 to 128
Protocol	1	1	<ESC> E L	0 = TCP 1 = UDP
Port	0		<ESC> E M	Range: 0 to 65535
Socket Type	1	1	<ESC> E N	0 = Server 1 = Client
Client Connection Startup Time (sec)	0		<ESC> E +	Range: 0 to 15
Server Address	2		<ESC> E O	Length: 0 to 256
Reading Phase ON String	2		<ESC> E P	Length: 1 to 128
Acquisition String	2		<ESC> E Q	Length: 1 to 128
Reading Phase OFF String	2		<ESC> E R	Length: 1 to 128
IMAGE SOCKET				
Status	1	1	<ESC> E S	0 = Disabled 1 = Enabled on Successful Decoding 2 = Enabled on Decoding Failure 3 = Always Enabled
Image Subsampling	1	1	<ESC> E T	0 = 1/1 1 = 1/4 2 = 1/16 3 = 1/64
Image Format	1	1	<ESC> E U	0 = BMP 1 = JPEG 2 = TIFF 3 = RAW
JPG Quality (1-100)	0		<ESC> E V	Range: 0 to 100
Protocol	1	1	<ESC> E W	0 = TCP 1 = UDP
Port	0		<ESC> E X	Range: 0 to 65535
Type	1	1	<ESC> E Y	0 = Server 1 = Client
Server Address	2		<ESC> E Z	Length: 0 to 256
WEB SENTINEL SOCKET				
Status	1	1	<ESC> E \$	0 = Disabled 1 = Enabled
Port	0		<ESC> E %	Range: 0 to 65535
IMAGE FTP CLIENT				
Status	1	1	<ESC> E a	0 = Disabled 1 = Enabled on Successful Decoding 2 = Enabled on Decoding Failure 3 = Always Enabled
Image Subsampling	1	1	<ESC> E b	0 = 1/1 1 = 1/4 2 = 1/16 3 = 1/64

PARAMETER	TYPE	SEL	STRING	DATA
Image Format	1	1	<ESC> E c	0 = BMP 1 = JPEG 2 = TIFF 3 = RAW
JPG Quality (1-100)	0		<ESC> E d	Range: 0 to 100
FTP Server Address	2		<ESC> E e	Length: 0 to 256
User Name	2		<ESC> E f	Length: 0 to 256
Password	2		<ESC> E g	Length: 0 to 256
Image Saving Path	2		<ESC> E h	Length: 0 to 256
Image File Name	2		<ESC> E i	Length: 0 to 256
Max Different Files To Save	0		<ESC> E j	Range: 0 to 1000000
File Type	1	1	<ESC> E k	0 = ASCII 1 = Binary
ETHERNET/IP				
Status	1	1	<ESC> E w	0 = Disabled 1 = Enabled
Header String	2		<ESC> E x	Length: 0 to 128
Terminator String	2		<ESC> E y	Length: 0 to 128
Keep Read Item	1	1	<ESC> e z	0 = Keep Always 1 = Discard After Read
MODBUS TCP				
Status	1	1	<ESC> M P	0 = Disabled 1 = Enabled
Header String	2		<ESC> M Q	Length: 0 to 128
Terminator String	2		<ESC> M R	Length: 0 to 128
Start Register	0		<ESC> M S	Range: 0 to 256
Number Of Registers	0		<ESC> M T	Range: 0 to 256 (valid when Type = Client)
Type	1	1	<ESC> M V	0 = Server 1 = Client
Server Address	2		<ESC> M U	Length: 0 to 256
Number Of Registers	0		<ESC> M Z	Range: 0 to 256 (valid when Type = Server)
HTTP SERVER				
Status	1	1	<ESC> E 1	0 = Disabled 1 = Enabled
GET IP CLIENT				
Product Name	2		<ESC> F J	Length: 0 to 15

4.5 CBX ETHERNET TCP/IP

25 PIN CONNECTOR MODELS + CBX ETHERNET TCP/IP MODULE (CBX Gateway folder)
ETHERNET MODELS + CBX ETHERNET TCP/IP MODULE (CBX Gateway folder)

PARAMETER	TYPE	SEL	STRING	DATA
CBX ETHERNET SYSTEM				
Status	1	1	<ESC> q A	0 = Disabled 1 = Enabled

PARAMETER	TYPE	SEL	STRING	DATA
DHCP Client	1	1	<ESC> q C	0 = Disabled 1 = Enabled
IP Address	2		<ESC> q D	Length: 0 to 15
Subnet Mask	2		<ESC> q E	Length: 0 to 15
Gateway Address	2		<ESC> q F	Length: 0 to 15
CBX ETHERNET DATA SOCKET				
Status	1	1	<ESC> q I	0 = Disabled 1 = Enabled
Header String	2		<ESC> q J	Length: 0 to 128
Terminator String	2		<ESC> q K	Length: 0 to 128
Protocol	1	1	<ESC> q L	0 = TCP 1 = UDP
Port	0		<ESC> q M	Range: 0 to 65535
Socket Type	1	1	<ESC> q N	0 = Server 1 = Client
Server Address	2		<ESC> q O	Length: 0 to 256
Reading Phase ON String	2		<ESC> q P	Length: 1 to 128
Acquisition String	2		<ESC> q Q	Length: 1 to 128
Reading Phase OFF String	2		<ESC> q R	Length: 1 to 128
CBX ETHERNET IMAGE SOCKET				
Status	1	1	<ESC> q S	0 = Disabled 1 = Enabled on Successful Decoding 2 = Enabled on Decoding Failure 3 = Always Enabled
Image Subsampling	1	1	<ESC> q T	0 = 1/1 1 = 1/4 2 = 1/16 3 = 1/64
Image Format	1	1	<ESC> q U	0 = BMP 1 = JPEG 2 = TIFF 3 = RAW
JPG Quality (1-100)	0		<ESC> q V	Range: 0 to 100
Protocol	1	1	<ESC> q W	0 = TCP 1 = UDP
Port	0		<ESC> q X	Range: 0 to 65535
Type	1	1	<ESC> q Y	0 = Server 1 = Client
Server Address	2		<ESC> q Z	Length: 0 to 256
CBX ETHERNET WEB SENTINEL SOCKET (not for Ethernet models)				
Status	1	1	<ESC> q \$	0 = Disabled 1 = Enabled
Port	0		<ESC> q %	Range: 0 to 65535
CBX ETHERNET IMAGE FTP CLIENT				
Status	1	1	<ESC> q a	0 = Disabled 1 = Enabled on Successful Decoding 2 = Enabled on Decoding Failure 3 = Always Enabled

PARAMETER	TYPE	SEL	STRING	DATA
Image Subsampling	1	1	<ESC> q b	0 = 1/1 1 = 1/4 2 = 1/16 3 = 1/64
Image Format	1	1	<ESC> q c	0 = BMP 1 = JPEG 2 = TIFF 3 = RAW
JPG Quality (1-100)	0		<ESC> q d	Range: 0 to 100
FTP Server Address	2		<ESC> q e	Length: 0 to 256
User Name	2		<ESC> q f	Length: 0 to 256
Password	2		<ESC> q g	Length: 0 to 256
Image Saving Path	2		<ESC> q h	Length: 0 to 256
Image File Name	2		<ESC> q i	Length: 0 to 256
Max Different Files To Save	0		<ESC> q j	Range: 0 to 1000000
File Type	1	1	<ESC> q k	0 = ASCII 1 = Binary
CBX ETHERNET/IP				
Status	1	1	<ESC> q w	0 = Disabled 1 = Enabled
Header String	2		<ESC> q x	Length: 0 to 128
Terminator String	2		<ESC> q y	Length: 0 to 128
Keep Read Item	1	1	<ESC> q z	0 = Keep Always 1 = Discard After Read
CBX ETHERNET MODBUS TCP				
Status	1	1	<ESC> M F	0 = Disabled 1 = Enabled
Header String	2		<ESC> M G	Length: 0 to 128
Terminator String	2		<ESC> M H	Length: 0 to 128
Start Register	0		<ESC> M I	Range: 0 to 256
Number Of Registers	0		<ESC> M J	Range: 0 to 256 (valid when Type = Client)
Type	1	1	<ESC> M L	0 = Server 1 = Client
Server Address	2		<ESC> M K	Length: 0 to 256
Number Of Registers	0		<ESC> M =	Range: 0 to 256 (valid when Type = Server)
CBX ETHERNET GET IP CLIENT				
Product Name	2		<ESC> F X	Length: 0 to 15

4.6 WEBSENTINEL

25-PIN CONNECTOR MODELS + CBX ETHERNET TCP/IP MODULE ETHERNET MODELS

PARAMETER	TYPE	SEL	STRING	DATA
WEB SENTINEL				
Status	1	1	<ESC> E =	0 = Disabled 1 = Enabled
Partial Read Is Treated As	1	1	<ESC> E &	0 = No Read 1 = Good Read 2 = Partial Read
Send Extended Parcel	1	1	<ESC> E ?	0 = Disabled 1 = Enabled

4.7 TRANSFER ARRAY IMAGE

ETHERNET MODELS

PARAMETER	TYPE	SEL	STRING	DATA
TRANSFER IMAGE MANAGER				
Status	1	1	<ESC> z i	0 = Disabled 1 = Enabled
Method *	1	1	<ESC> z r	0 = On Demand 1 = Timeout
Timeout	0	1	<ESC> z s	Range: 1 to 3600
Image Stored Buffer Size	0	1	<ESC> z j	Range: 1 to 65535
Saving Event	4	4	<ESC> z k	1 = No Reads 2 = Multiple Reads 4 = Partial Reads 8 = Good Reads
Image Subsampling	1	1	<ESC> z o	0 = 1/1 1 = 1/4 2 = 1/16 3 = 1/64
Image Format	1	1	<ESC> z p	0 = BMP 1 = JPG 2 = TIFF 3 = RAW
Jpg Quality (1-100)	0	1	<ESC> z q	Range: 1 to 100
TRANSFER IMAGE FTP CLIENT				
Image Saving Path	2	1	<ESC> z t	Length: 0 to 256
FTP Server Address	2	1	<ESC> z u	Length: 0 to 256
User Name	2	1	<ESC> z v	Length: 0 to 256
Password	2	1	<ESC> z w	Length: 0 to 256



See Appendix A for On Demand Transfer Array Image command.

NOTE

4.8 READING SYSTEM LAYOUT

25 PIN CONNECTOR MODELS ETHERNET MODELS

PARAMETER	TYPE	SEL	STRING	DATA
READING SYSTEM LAYOUT				
Device Network Setting	1	1	<ESC> A R	0 = Alone Or ID-NET 1 = Master RS232 (Type A) 2 = Slave RS232 (Type A) 3 = Master RS232 (Type M) 4 = Slave RS232 (Type M)
Number of Slaves (Type A or M)	0		<ESC> A S	Range: 1 to 9
Link Failure String	2		<ESC> A T	Length: 0 to 32
Link Failure Timeout (ms)	0		<ESC> A U	Range: 10 to 10000
DEVICE NETWORK SETTING				
Topology Role	1	1	<ESC> A a	0 = Other 1 = Master (Synchronized) 2 = Slave (Synchronized) 3 = Master (Multidata) 4 = Slave (Multidata)
Slave Address	0		<ESC> A b	Range: 1 to 31
Network Baud Rate (bps)	1	1	<ESC> A c	0 = 19200 1 = 38400 2 = 57600 3 = 125 Kb 4 = 250 Kb 5 = 500 Kb 6 = 1 Mb
Link Failure String	2		<ESC> A d	Length: 0 to 32
Link Failure Timeout (ms)	0		<ESC> A e	Range: 10 to 10000
Header String (Slave Multidata)	2		<ESC> A f	Length: 0 to 128
Terminator String (Slave Multidata)	2		<ESC> A g	Length: 0 to 128
Reading Phase ON String	2		<ESC> A j	Length: 1 to 128
Acquisition String	2		<ESC> A k	Length: 1 to 128
Reading Phase OFF String	2		<ESC> A m	Length: 1 to 128
Address TX (Master Multidata)	1	1	<ESC> A h	0 = Disabled 1 = Enabled
Address Header String (Master Multidata)	2		<ESC> A i	Length: 0 to 32
Address Separator String (Master Multidata)	2		<ESC> A l	Length: 0 to 32
EXPECTED SLAVE DEVICE (DEPTH: n = 1 to 31)				
Device Status #n	1	1	<ESC> J #n	0 = Disabled 1 = Enabled
Device Description #n	2		<ESC> K #n	Length: 0 to 16



NOTE

Special characters <FE_H> and <FD_H> must be added after #n in the programming string to indicate parameter **Depth** > 9. Refer to paragraph 3.2 for further details.

4.9 CBX GATEWAY

25 PIN CONNECTOR MODELS + CBX HOST INTERFACE MODULES ETHERNET MODELS + CBX HOST INTERFACE MODULES



WARNING See Appendix B "CBX Gateway Fieldbus Reset" for a list of parameters which produce a Fieldbus reset.

PARAMETER	TYPE	SEL	STRING	DATA
HOST INTERFACE				
Host Interface Type	1	1	<ESC> S A	0 = None 1 = Profibus 2 = DeviceNet 3 = Ethernet/IP 4 = CC-Link 5 = CAN Open 6 = Profinet IO 7 = Modbus TCP 8 = Ethernet TCP/IP
FIELDBUS				
Data TX	1	1	<ESC> S B	0 = Disabled 1 = Enabled
Header String	2		<ESC> S D	Length: 0 to 128
Terminator String	2		<ESC> S E	Length: 0 to 128
Reading Phase ON String	2		<ESC> S F	Length: 1 to 128
Reading Phase OFF String	2		<ESC> S G	Length: 1 to 128
Acquisition Trigger String	2		<ESC> S H	Length: 1 to 128
PROFIBUS				
Master Input Area Size	0		<ESC> S I	Range: 8 to 144
Master Output Area Size	0		<ESC> S J	Range: 8 to 144
Node Address	0		<ESC> S K	Range: 0 to 126
Data Flow Control	1	1	<ESC> S L	0 = Disabled 1 = DAD Driver 2 = DPD Driver
Data Consistency	1	1	<ESC> S M	0 = Disabled 1 = Enabled
DEVICENET				
Master Input Area Size	0		<ESC> S N	Range: 8 to 144
Master Output Area Size	0		<ESC> S O	Range: 8 to 144
Node Address	0		<ESC> S P	Range: 0 to 64
Data Flow Control	1	1	<ESC> S Q	0 = Disabled 1 = DAD Driver 2 = DPD Driver

PARAMETER	TYPE	SEL	STRING	DATA
Data Consistency	1	1	<ESC> S R	0 = Disabled 1 = Enabled
ETHERNET/IP				
Master Input Area Size	0		<ESC> S a	Range: 8 to 144
Master Output Area Size	0		<ESC> S b	Range: 8 to 144
Data Flow Control	1	1	<ESC> S c	0 = Disabled 1 = DAD Driver 2 = DPD Driver
Data Consistency	1	1	<ESC> S d	0 = Disabled 1 = Enabled
IP Addressing Mode	1	1	<ESC> S e	0 = Static Assignment 1 = DHCP 2 = Remote Assignment
IP Address (Static Addressing)	2		<ESC> S f	Length: 1 to 15
Subnet Mask (Static Addressing)	2		<ESC> S g	Length: 1 to 15
Gateway Address (Static Addressing)	2		<ESC> S h	Length: 1 to 15
CC-LINK				
Master Input Area Size	0		<ESC> S i	Range: 2 to 126
Master Output Area Size	0		<ESC> S j	Range: 2 to 128
Node Address	0		<ESC> S k	Range: 1 to 64
Data Flow Control	1	1	<ESC> S l	0 = Disabled 1 = DAD Driver 2 = DPD Driver
Data Consistency	1	1	<ESC> S m	0 = Disabled 1 = Enabled
Baud Rate	1	1	<ESC> S n	0 = 56kbps 1 = 625kbps 2 = 2.5Mbps 3 = 5Mbps 4 = 10Mbps
Version (CC-Link Controller Software Version)	0		<ESC> S o	Range: 1 to 2
CAN OPEN				
Master Input Area Size	0		<ESC> S p	Range: 8 to 144
Master Output Area Size	0		<ESC> S q	Range: 8 to 144
Node Address	0		<ESC> S r	Range: 1 to 128
Data Flow Control	1	1	<ESC> S s	0 = Disabled 1 = DAD Driver 2 = DPD Driver
Data Consistency	1	1	<ESC> S t	0 = Disabled 1 = Enabled
PROFINET IO				
Master Input Area Size	0		<ESC> S u	Range: 8 to 56
Master Output Area Size	0		<ESC> S v	Range: 8 to 56

PARAMETER	TYPE	SEL	STRING	DATA
Data Flow Control	1	1	<ESC> S w	0 = Disabled 1 = DAD Driver 2 = DPD Driver
Data Consistency	1	1	<ESC> S x	0 = Disabled 1 = Enabled
IP Addressing	1	1	<ESC> S y	0 = Static Assignment 1 = DHCP 2 = Remote Assignment
IP Address (Static Addressing)	2		<ESC> S z	Length: 1 to 15
Subnet Mask (Static Addressing)	2		<ESC> S !	Length: 1 to 15
Gateway Address (Static Addressing)	2		<ESC> S #	Length: 1 to 15
Station Name	2		<ESC> S \$	Length: 1 to 32
MODBUS TCP				
Master Input Area Size	0		<ESC> S %	Range: 8 to 144
Master Output Area Size	0		<ESC> S &	Range: 8 to 144
Data Flow Control	1	1	<ESC> S (0 = Disabled 1 = DAD Driver 2 = DPD Driver
Data Consistency	1	1	<ESC> S)	0 = Disabled 1 = Enabled
IP Addressing	1	1	<ESC> S *	0 = Static Assignment 1 = DHCP 2 = Remote Assignment
IP Address (Static Addressing)	2		<ESC> S +	Length: 1 to 15
Subnet Mask (Static Addressing)	2		<ESC> S /	Length: 1 to 15
Gateway Address (Static Addressing)	2		<ESC> S :	Length: 1 to 15
Process Active Timeout (ms)	0		<ESC> S -	Range: 0 to 65535
Connection Timeout (sec)	0		<ESC> S {	Range: 0 to 65535
DIGITAL I/O CONDITIONING				
Phase Echo	1	1	<ESC> S S	0 = Disabled 1 = Enabled
External Trigger Echo	1	1	<ESC> S T	0 = Disabled 1 = Enabled
Input 2 Echo	1	1	<ESC> S U	0 = Disabled 1 = Enabled
Output 1	1	1	<ESC> S V	0 = Disabled 1 = Enabled
Output 2	1	1	<ESC> S W	0 = Disabled 1 = Enabled

4.10 IMAGE PROCESSING

PARAMETER	TYPE	SEL	STRING	DATA
IMAGE PROCESSING SETUP				
Processing Mode	1	1	<ESC> F A	0 = Standard, 1 = Advanced Code Setting 2 = Low Height Codes
Identical Codes Decoding	1	1	<ESC> F B	0 = Disabled 1 = Enabled
Image Lighting Quality	1	1	<ESC> F C	0 = Disabled 1 = Enabled
Image Mirroring	1	1	<ESC> F D	0 = Disabled 1 = Enabled
Image Processing Timeout (ms)	0		<ESC> F F	Range: 1 to 30000
Image Processing Timeout Precision	1	1	<ESC> J -	0 = Standard 1 = High
Self Tuning	1	1	<ESC> F O	0 = Disabled 1 = Enabled
Self Tuning Mode	1	1	<ESC> F P	0 = Symbologies Only 1 = Processing Modes Only 2 = Decoding Methods Only 3 = Code Contrast Levels Only 4 = Image Mirroring Only 5 = General Purpose
Self Tuning Timeout (ms)	0		<ESC> F Q	Range: 0 to 180000 (0 = Disabled)

4.11 2D CODES

PARAMETER	TYPE	SEL	STRING	DATA
2D CODES SETUP				
Code Color	1	1	<ESC> G C	0 = Black 1 = White 2 = Both Colors
Code Contrast	1	1	<ESC> F E	0 = High 1 = Standard 2 = Low 3 = Very Low 4 = Automatic
DATA MATRIX ECC200				
Status	1	1	<ESC> G A	0 = Disabled 1 = Enabled
Decoding Method	1	1	<ESC> G J	0 = Standard 1 = Direct Marking
Rectangular Formats	1	1	<ESC> G B	0 = Disabled 1 = Enabled
Decoding Performance	1	1	<ESC> G Z	0 = Quick 1 = Robust
Advanced Box Improvement	1	1	<ESC> F G	0 = Disabled 1 = Enabled
Code Orientation	1	1	<ESC> G H	0 = Aligned 1 = Free

PARAMETER	TYPE	SEL	STRING	DATA
Code Size	1	1	<ESC> G I	0 = Defined 1 = Free
Number Of Modules	4	30	<ESC> G K	1 = 10x10 2 = 12x12 4 = 14x14 8 = 16x16 16 = 18x18 32 = 8x18 64 = 20x20 128 = 22x22 256 = 24x24 512 = 26x26 1024 = 12x26 2048 = 32x32 4096 = 8x32 8192 = 12x36 16384 = 16x36 32576 = 16x48 65536 = 36x36 131072 = 40x40 262144 = 44x44 524288 = 48x48 1048576 = 52x52 2097152 = 64x64 4194304 = 72x72 8388608 = 80x80 16777216 = 88x88 33554432 = 96x96 67108864 = 104x104 134217728 = 120x120 268435456 = 132x132 536870912 = 144x144
Module Size (mils)	0		<ESC> G F	Range: 1 to 1000
Decoding Time Improvement	1	1	<ESC> F R	0 = Disabled 1 = Enabled
Legacy	1	1	<ESC> G -	0 = Disabled 1 = Enabled
QR CODE				
Status	1	1	<ESC> G O	0 = Disabled 1 = Enabled
Decoding Method	1	1	<ESC> G Y	0 = Standard 1 = Direct Marking
Module Size (mils)	0		<ESC> G V	Range: 1 to 1000
MICRO QR CODE				
Status	1	1	<ESC> G G	0 = Disabled 1 = Enabled
AZTEC CODE				
Status	1	1	<ESC> G Q	0 = Disabled 1 = Enabled
MAXICODE				
Status	1	1	<ESC> G S	0 = Disabled 1 = Enabled

PARAMETER	TYPE	SEL	STRING	DATA
Modes	4	7	<ESC> G T	1 = 0 2 = 1 4 = 2 8 = 3 16 = 4 32 = 5 64 = 6
Partial Code TX	1	1	<ESC> G W	0 = Disabled 1 = Enabled

4.12 1D CODES

PARAMETER	TYPE	SEL	STRING	DATA
1D CODES SETUP				
Minimum Code Height (mm)	0		<ESC> F I	Range: 1 to 500
Code Aspect Ratio	1	1	<ESC> F K	0 = Standard 1 = Low
Code Contrast	1	1	<ESC> F L	0 = Standard 1 = Low
Small Codes Improvement	1	1	<ESC> F M	0 = Disabled 1 = Enabled
Advanced Box Improvement	1	1	<ESC> F N	0 = Disabled 1 = Enabled
Tires Improvement	1	1	<ESC> F T	0 = Disabled 1 = Method 1 (Scans) 2 = Method 2 (Sigma ROI)
Tires Sigma ROI Algorithm (Severity)	1	1	<ESC> F +	0 = Basic 1 = Advanced
Code Search Priority	1	1	<ESC> F -	0 = Horizontal/Vertical 1 = 45 Degrees
PDF417				
Status	1	1	<ESC> H A	0 = Disabled 1 = Enabled
MICRO PDF417				
Status	1	1	<ESC> H y	0 = Disabled 1 = Enabled
CODE 128				
Status	1	1	<ESC> H C	0 = Disabled 1 = Enabled
Narrow Margins	1	1	<ESC> H D	0 = Disabled 1 = Enabled
Start/Stop Characters TX	1	1	<ESC> H T	0 = Disabled 1 = Enabled
Characters TX	1	1	<ESC> H S	0 = Disabled 1 = Enabled
GS1-128 (ex EAN 128)				
Status	1	1	<ESC> H E	0 = Disabled 1 = Enabled

PARAMETER	TYPE	SEL	STRING	DATA
Narrow Margins	1	1	<ESC> H F	0 = Disabled 1 = Enabled
Start/Stop Characters TX	1	1	<ESC> H R	0 = Disabled 1 = Enabled
CODE 39				
Status	1	1	<ESC> H G	0 = Disabled 1 = Enabled
Character Set	1	1	<ESC> H I	0 = Standard 1 = Full ASCII
Check Digit Status	1	1	<ESC> H J	0 = Disabled 1 = Enabled
Check Digit TX	1	1	<ESC> H K	0 = Disabled 1 = Enabled
Narrow Margins	1	1	<ESC> H L	0 = Disabled 1 = Enabled
Code 32 Decoding	1	1	<ESC> G z	0 = Disabled 1 = Enabled
INTERLEAVED 2 OF 5				
Status	1	1	<ESC> H N	0 = Disabled 1 = Enabled
Check Digit Status	1	1	<ESC> H O	0 = Disabled 1 = Enabled
Check Digit TX	1	1	<ESC> H P	0 = Disabled 1 = Enabled
Narrow Margins	1	1	<ESC> H Q	0 = Disabled 1 = Enabled
Decoding Severity	1	1	<ESC> H -	0 = Standard 1 = High
Minimum Number of Characters	0		<ESC> H M	Range: 2 to 60
PHARMACODE				
Status	1	1	<ESC> H V	0 = Disabled 1 = Enabled
Output Format	1	1	<ESC> H W	0 = Binary 1 = Encoded
Minimum Bar Count	0		<ESC> H X	Range: 4 to 16
Maximum Bar Count	0		<ESC> H Y	Range: 4 to 16
Decoded Minimum Value	0		<ESC> H Z	Range: 15 to 131070
Decoded Maximum Value	0		<ESC> H a	Range: 15 to 131070
Code Orientation	1	1	<ESC> H b	0 = Horizontal 1 = Vertical
Direction of Decoding	1	1	<ESC> H c	0 = Normal 1 = Reverse
Colored Bars Check	1	1	<ESC> H B	0 = Disabled 1 = Enabled
MSI				
Status	1	1	<ESC> I d	0 = Disabled 1 = Enabled

PARAMETER	TYPE	SEL	STRING	DATA
Check Digit Status	1	1	<ESC> l e	0 = Disabled 1 = Enabled Mod 10 2 = Enabled Mod 10 + Mod11 3 = Enabled 2 Mod 10
Check Digit TX	1	1	<ESC> l f	0 = Disabled 1 = Enabled
Narrow Margins	1	1	<ESC> l g	0 = Disabled 1 = Enabled
STANDARD 2 OF 5				
Status	1	1	<ESC> H z	0 = Disabled 1 = Enabled
Check Digit Status	1	1	<ESC> l a	0 = Disabled 1 = Enabled
Check Digit TX	1	1	<ESC> l b	0 = Disabled 1 = Enabled
Narrow Margins	1	1	<ESC> l c	0 = Disabled 1 = Enabled
MATRIX 2 OF 5				
Status	1	1	<ESC> H s	0 = Disabled 1 = Enabled
Check Digit Status	1	1	<ESC> H t	0 = Disabled 1 = Enabled
Check Digit TX	1	1	<ESC> H u	0 = Disabled 1 = Enabled
Narrow Margins	1	1	<ESC> H v	0 = Disabled 1 = Enabled
UPC/EAN FAMILY				
Status	1	1	<ESC> H d	0 = Disabled 1 = Enabled
ADDON 2 and 5 Status	1	1	<ESC> H e	0 = Disabled 1 = Enabled 2 = Enabled (+AddOn 2 No Quiet Zone)
Expand UPC E0-E1 symbols	1	1	<ESC> H f	0 = Disabled 1 = Enabled
Narrow Margins	1	1	<ESC> H g	0 = Disabled 1 = Enabled
Margin Size (%) (% of narrow module size)	1	1	<ESC> H w	0 = 200 1 = 250 2 = 300 3 = 350 4 = 400 5 = 450
CODABAR				
Status	1	1	<ESC> H i	0 = Disabled 1 = Enabled
Narrow Margins	1	1	<ESC> H j	0 = Disabled 1 = Enabled
Check Digit Status	1	1	<ESC> H h	0 = Disabled 1 = Enabled
Check Digit TX	1	1	<ESC> H k	0 = Disabled 1 = Enabled

PARAMETER	TYPE	SEL	STRING	DATA
Start/Stop Characters TX	1	1	<ESC> H \$	0 = Disabled 1 = Enabled
CODE 93				
Status	1	1	<ESC> H I	0 = Disabled 1 = Enabled
Narrow Margins	1	1	<ESC> H m	0 = Disabled 1 = Enabled
GS1 DATABAR EXPANDED				
Status	1	1	<ESC> H n	0 = Disabled 1 = Enabled
GS1 DATABAR EXPANDED STACKED				
Status	1	1	<ESC> H x	0 = Disabled 1 = Enabled
GS1 DATABAR LIMITED				
Status	1	1	<ESC> H o	0 = Disabled 1 = Enabled
GS1 DATABAR GS1 DATABAR TRUNCATED				
Status	1	1	<ESC> H p	0 = Disabled 1 = Enabled
GS1 DATABAR STACKED GS1 DATABAR STACKED OMNIDIRECTIONAL				
Status	1	1	<ESC> H q	0 = Disabled 1 = Enabled
COMPOSITE				
Status	1	1	<ESC> H r	0 = Disabled 1 = Enabled

 NOTE	<p><i>GS1 DataBar option also enables GS1 DataBar Truncated symbology, while GS1 DataBar Stacked option also enables GS1 DataBar Stacked Omnidirectional symbology.</i></p>
--	---

4.13 POSTAL CODES

PARAMETER	TYPE	SEL	STRING	DATA
POSTAL CODES				
Status (Set which of the postal symbologies is enabled for decoding)	1	1	<ESC> I A	0 = Disabled 1 = Australia Post 2 = Royal Mail 4State 3 = KIX Code 4 = Japan Post 5 = Planet 6 = PostNet 7 = PostNet (+BB') 8 = PostNet + Planet 9 = PostNet (+BB') + Planet 10 = Intelligent Mail 11 = Intelligent Mail + PostNet 12 = Intelligent Mail + PostNet (+ BB') 13 = Intelligent Mail + Planet 14 = Intelligent Mail + Planet + PostNet 15 = Intelligent Mail + Planet + PostNet (+ BB') 16 = Swedish Postal
Customer Field Decoding (Australia Post)	1	1	<ESC> I G	0 = N Decoding Table 1 = C Decoding Table 2 = Bars Value (Decimal)
Minimum Bar Count	0		<ESC> I C	Range: 24 to 72
Maximum Bar Count	0		<ESC> I D	Range: 24 to 72
Code Orientation	1	1	<ESC> I E	0 = Omnidirectional 1 = Horizontal 2 = Vertical 3 = Horizontal and Vertical
Bar Edge Spacing (mils)	0		<ESC> I F	Range: 12 to 40

4.14 DATA COLLECTION

25 PIN CONNECTOR MODELS ETHERNET MODELS

PARAMETER	TYPE	SEL	STRING	DATA
CODE COLLECTION				
Code Collection Mode	1	1	<ESC> J A	0 = Within an Image 1 = Within a Phase
Number of Codes	0		<ESC> J B	Range: 1 to 250
Multiple Read	1	1	<ESC> J D	0 = Disabled 1 = Enabled
Code Collection Filters	1	1	<ESC> J C	0 = Disabled 1 = Enabled
Minimum Phase Duration (ms)	0		<ESC> J G	Range: 0 to 65000
CODE FILTER SETTING (DEPTH: n = 1 to 100)				
Status #n	1	1	<ESC> p #n	0 = Disabled 1 = Enabled

PARAMETER	TYPE	SEL	STRING	DATA
Symbology #n	1	1	<ESC> q #n	0 = Interleaved 2 of 5 1 = Code 39 2 = Code 39 Full ASCII 3 = Codabar 4 = Code 128 5 = GS1-128 (ex EAN 128) 6 = Code 93 7 = EAN-13 8 = EAN-8 9 = UPC-A 10 = UPC-E 11 = EAN-13 Addon 2 12 = EAN-8 Addon 2 13 = UPC-A Addon 2 14 = UPC-E Addon 2 15 = EAN-13 Addon 5 16 = EAN-8 Addon 5 17 = UPC-A Addon 5 18 = UPC-E Addon 5 19 = Data Matrix ECC200 20 = PDF417 21 = QR Code 22 = Maxicode 23 = Australia Post 24 = POSTNET 25 = PLANET 26 = Japan Post 27 = KIX Code 28 = Royal Mail 29 = GS1 DataBar Expanded 30 = GS1 DataBar Expanded Stacked 31 = GS1 DataBar Limited 32 = GS1 DataBar 33 = GS1 DataBar Stacked 34 = Micro PDF417 35 = Code 128 of Composite 36 = CC-A of Composite 37 = CC-B of Composite 38 = CC-C of Composite 39 = GS1 DataBar Expanded of Composite 40 = GS1 DataBar Expanded Stacked of Composite 41 = GS1 DataBar Limited of Composite 42 = GS1 DataBar of Composite 43 = GS1 DataBar Stacked of Composite 44 = Pharmacode 45 = Aztec Code 46 = OCR OCV 47 = Intelligent Mail 48 = Micro QR Code 49 = Swedish Postal 50 = GS1 Data Matrix 51 = Matrix 2 of 5 52 = Standard 2 of 5 53 = MSI 54 = Code 32 55 = Locator Edge

PARAMETER	TYPE	SEL	STRING	DATA
Minimum Number of Characters <i>#n</i>	0		<ESC> r <i>#n</i>	Range: 1 to 3116
Maximum Number of Characters <i>#n</i>	0		<ESC> s <i>#n</i>	Range: 1 to 3116
Code Position Frame: Top <i>#n</i>	0		<ESC> N <i>#n</i>	Range: 0 to 5000
Code Position Frame: Bottom <i>#n</i>	0		<ESC> O <i>#n</i>	Range: 0 to 5000
Code Position Frame: Left <i>#n</i>	0		<ESC> L <i>#n</i>	Range: 0 to 5000
Code Position Frame: Right <i>#n</i>	0		<ESC> M <i>#n</i>	Range: 0 to 5000
Code Quality Index <i>#n</i>	1	1	<ESC> P <i>#n</i>	0 = ISO-IEC / AIM DPM Overall Grade 1 = ISO-IEC Symbol Contrast 2 = ISO-IEC Print Growth 3 = ISO-IEC / AIM DPM Axial Non-Uniformity 4 = ISO-IEC / AIM DPM Unused ECC 5 = ISO-IEC / AIM DPM Decode 6 = ISO-IEC Modulation 7 = ISO-IEC Mean Edge Contrast 8 = ISO-IEC Decodability 9 = ISO-IEC / AIM DPM Fixed Pattern Damage 10 = ISO-IEC / AIM DPM Grid Non-Uniformity 11 = ISO-IEC / AIM DPM Minimum Reflectance 12 = ISO-IEC Defects 13 = AIM DPM Cell Contrast 14 = AIM DPM Cell Modulation 15 = AS9132 Dot Size/Cell Fill 16 = AS9132 Dot Center Offset 17 = AS9132 Dot Ovality 18 = AS9132 Quiet Zone 19 = AS9132 Symbol Contrast 20 = AS9132 Angle Of Distortion 21 = None
ISO-IEC 16022-18004 Threshold	1	1	<ESC> Q <i>#n</i>	0 = Any Grade 1 = Grade A 2 = Grade B 3 = Grade C 4 = Grade D
ISO-IEC 15415 Threshold	1	1	<ESC> R <i>#n</i>	0 = Any Grade 1 = Grade A 2 = Grade B 3 = Grade C 4 = Grade D
ISO-IEC 15416 Threshold	1	1	<ESC> S <i>#n</i>	0 = Any Grade 1 = Grade A 2 = Grade B 3 = Grade C 4 = Grade D
AIM DPM Threshold	1	1	<ESC> T <i>#n</i>	0 = Any Grade 1 = Grade A 2 = Grade B 3 = Grade C 4 = Grade D

PARAMETER	TYPE	SEL	STRING	DATA
Match Code #n	2		<ESC> w #n	Length: 1 to 3116
Wildcard Character #n	2		<ESC> u #n	Length: 1
Placeholder Character #n	2		<ESC> v #n	Length: 1
Local No-Read Message #n	2		<ESC> t #n	Length: 0 to 64
Local Multiple Read Message #n	2		<ESC> > #n	Length: 0 to 64

 **NOTE** Special characters <FE_H> and <FD_H> must be added after #n in the programming string to indicate parameter **Depth > 9**. Refer to paragraph 3.2 for further details.

PARAMETER	TYPE	SEL	STRING	DATA
DATA FORMAT				
Code Field Justification	1	1	<ESC> K A	0 = Disabled 1 = Left 2 = Right
Code Field Length	0		<ESC> K B	Range: 1 to 3116
Fill Character	2		<ESC> K C	Length: 1
Code Field Cutting	1	1	<ESC> K D	0 = None 1 = Beginning 2 = Middle 3 = End
Separator String	2		<ESC> K E	Length: 1 to 32
(Global) No Read message	2		<ESC> K F	Length: 0 to 64
(Global) Multiple Read message	2		<ESC> J E	Length: 0 to 64
Phase-Overrun Message	2		<ESC> K I	Length: 0 to 16
Data Packet Separator string	2		<ESC> K G	Length: 0 to 32
Data Packet Format (%1, %2, ... are special characters)	2		<ESC> K J	Length: 0 to 128 %1 = Code Identifier %2 = Code Data %3 = Code Center (X-axis) %4 = Code Center (Y-axis) %5 = Code Orientation %6 = Code Quality Index (%) %8 = Image Lighting Quality (%) %A = Code Producer ID (Master RS232 or Master Synchronized) %M = Code Data Length %N = Decode Time (ms) %O = Reading Phase Counter %P = Acquisition Counter %_ = Global Diagnostic Status %C = ISO-IEC / AIM DPM Overall (Grade) %D = ISO-IEC / AIM DPM Overall (Value)

PARAMETER	TYPE	SEL	STRING	DATA
				%E = ISO-IEC Symbol Contrast / AIM DPM Cell Contrast (grade) %F = ISO-IEC Symbol Contrast / AIM DPM Cell Contrast (value) %G = ISO-IEC Print Growth (grade) %H = ISO-IEC Print Growth (value) %I = ISO-IEC / AIM DPM Axial Non-Uniformity (grade) %J = ISO-IEC / AIM DPM Axial Non-Uniformity (value) %K = ISO-IEC / AIM DPM Unused ECC (grade) %L = ISO-IEC / AIM DPM Unused ECC (value) %a = ISO-IEC / AIM DPM Decode (grade) %Q = ISO-IEC Modulation / AIM DPM Cell Modulation (grade) %R = ISO-IEC Modulation / AIM DPM Cell Modulation (value) %S = ISO-IEC Mean Edge Contrast (grade) %T = ISO-IEC Mean Edge Contrast (value) %U = ISO-IEC Decodability (grade) %V = ISO-IEC Decodability (value) %m = ISO-IEC / AIM DPM Fixed Pattern Damage (grade) %W = ISO-IEC / AIM DPM Fixed Pattern Damage (value) %n = ISO-IEC / AIM DPM Grid Non-Uniformity (grade) %X = ISO-IEC / AIM DPM Grid Non-Uniformity (value) %o = ISO-IEC / AIM DPM Minimum Reflectance (grade) %Y = ISO-IEC / AIM DPM Minimum Reflectance (value) %p = ISO-IEC Defects (grade) %Z = ISO-IEC Defects (value) %q = AS9132 Dot Size/Cell Fill (grade) %u = AS9132 Dot Size/Cell Fill (value) %r = AS9132 Dot Center Offset (grade) %v = AS9132 Dot Center Offset (value) %s = AS9132 Dot Ovality (Grade) %w = AS9132 Dot Ovality (value) %t = AS9132 Angle Of Distortion (grade) %y = AS9132 Angle Of Distortion (value) %z = AS9132 Quiet Zone (grade) %0 = AS9132 Quiet Zone (value) %b = AS9132 Symbol Contrast (grade) %c = AS9132 Symbol Contrast (value) %* = Data Matrix Setting Information
Statistics Field Separator String	2		<ESC> K H	Length: 0 to 32

PARAMETER	TYPE	SEL	STRING	DATA
Statistics Field Format (%0, %1, ... are special characters)	2		<ESC> K S	Length: 0 to 128 %0 = Phase or Acquisition Counter to WebSentinel %1 = Phase Overrun Message %2 = Phase or Acquisition Counter %3 = No Read Counter %4 = Partial Read Counter %5 = Complete Read Counter %6 = Right Code Counter (Match Code enabled) %7 = Wrong Code Counter (Match Code enabled) %8 = Multiple Read Counter %! = Image Processing Time (ms)
Symbology Identifiers	1	1	<ESC> K K	0 = Disabled 1 = Enabled
SYMBOLOGY IDENTIFIERS				
Data Matrix ECC200	2		<ESC> L A	Length: 0 to 32
GS1 Data Matrix	2		<ESC> L >	Length: 0 to 32
QR Code	2		<ESC> L C	Length: 0 to 32
Micro QR Code	2		<ESC> L Z	Length: 0 to 32
Aztec Code	2		<ESC> L D	Length: 0 to 32
Maxicode	2		<ESC> L E	Length: 0 to 32
PDF417	2		<ESC> L B	Length: 0 to 32
Micro PDF417	2		<ESC> L y	Length: 0 to 32
Interleaved 2 of 5	2		<ESC> L X	Length: 0 to 32
Code 39	2		<ESC> L V	Length: 0 to 32
Code 39 Full ASCII	2		<ESC> L W	Length: 0 to 32
Codabar	2		<ESC> L v	Length: 0 to 32
Code 128	2		<ESC> L T	Length: 0 to 32
GS1-128 (ex EAN 128)	2		<ESC> L U	Length: 0 to 32
Code 93	2		<ESC> L w	Length: 0 to 32
EAN-13	2		<ESC> L e	Length: 0 to 32
EAN-8	2		<ESC> L f	Length: 0 to 32
UPC-A	2		<ESC> L g	Length: 0 to 32
UPC-E	2		<ESC> L h	Length: 0 to 32
EAN-13 AddOn 2	2		<ESC> L i	Length: 0 to 32
EAN-8 AddOn 2	2		<ESC> L j	Length: 0 to 32
UPC-A AddOn 2	2		<ESC> L k	Length: 0 to 32
UPC-E AddOn 2	2		<ESC> L m	Length: 0 to 32
EAN-13 AddOn 5	2		<ESC> L n	Length: 0 to 32
EAN-8 AddOn 5	2		<ESC> L o	Length: 0 to 32
UPC-A AddOn 5	2		<ESC> L p	Length: 0 to 32
UPC-E AddOn 5	2		<ESC> L q	Length: 0 to 32
Australia Post	2		<ESC> L F	Length: 0 to 32
PostNet	2		<ESC> L G	Length: 0 to 32
Planet	2		<ESC> L H	Length: 0 to 32
Japan Post	2		<ESC> L I	Length: 0 to 32
KIX Code	2		<ESC> L J	Length: 0 to 32
Royal Mail 4 State	2		<ESC> L K	Length: 0 to 32
Intelligent Mail	2		<ESC> L Y	Length: 0 to 32
Swedish Postal	2		<ESC> L ?	Length: 0 to 32
GS1 DataBar Expanded	2		<ESC> L r	Length: 0 to 32
GS1 DataBar Expanded Stacked	2		<ESC> L x	Length: 0 to 32

PARAMETER	TYPE	SEL	STRING	DATA
GS1 DataBar Limited	2		<ESC> L s	Length: 0 to 32
GS1 DataBar	2		<ESC> L t	Length: 0 to 32
GS1 DataBar Stacked	2		<ESC> L u	Length: 0 to 32
Code 128 of Composite	2		<ESC> L L	Length: 0 to 32
GS1 DataBar Expanded of Composite	2		<ESC> L M	Length: 0 to 32
GS1 DataBar Expanded Stacked of Composite	2		<ESC> L z	Length: 0 to 32
GS1 DataBar Limited of Composite	2		<ESC> L N	Length: 0 to 32
GS1 DataBar of Composite	2		<ESC> L O	Length: 0 to 32
GS1 DataBar Stacked of Composite	2		<ESC> L P	Length: 0 to 32
CC-A of Composite	2		<ESC> L Q	Length: 0 to 32
CC-B of Composite	2		<ESC> L R	Length: 0 to 32
CC-C of Composite	2		<ESC> L S	Length: 0 to 32
Pharmacode	2		<ESC> L a	Length: 0 to 32
MSI	2		<ESC> L <	Length: 0 to 32
Standard 2 of 5	2		<ESC> L -	Length: 0 to 32
Matrix 2 of 5	2		<ESC> L [Length: 0 to 32
Code 32	2		<ESC> L _	Length: 0 to 32
DATA TRANSMISSION				
Partial Read TX	1	1	<ESC> K L	0 = Disabled 1 = Enabled
Message TX Selection	1	1	<ESC> K M	0 = On Complete Read 1 = After Reading Phase OFF 2 = Delayed TX Line 3 = Delayed TX Line On Input
Reference Input Signal	4	4	<ESC> K T	1 = Ext. Trigger Leading Edge 2 = Ext. Trigger Trailing Edge 4 = Input 2 Leading Edge 8 = Input 2 Trailing Edge
Conveyor Speed (mm/sec)	0		<ESC> K V	Range: 50 to 10000
Delayed TX Line Distance (mm)	0		<ESC> K Z	Range: 100 to 20000
Physical Encoder	1	1	<ESC> K W	0 = Disabled 1 = Enabled
Encoder Step (hundredths of mm)	0		<ESC> K X	Range: 1 to 10000
Output Lines Activation	1	1	<ESC> K N	0 = On Complete Read 1 = After Reading Phase OFF
STATISTICS				
Status	1	1	<ESC> K O	0 = Disabled 1 = Enabled
Number of Samples	0		<ESC> K P	Range: 5 to 1000
Output Format	1	1	<ESC> K Q	0 = % (on Last Samples) 1 = N/M (on Last Samples) 2 = %+N/M (on Last Samples) 3 = % (on All Samples) 4 = N/M (on All Samples) 5 = %+N/M (on All Samples)

PARAMETER	TYPE	SEL	STRING	DATA
Last Read Code TX	1	1	<ESC> K R	0 = Disabled 1 = Enabled 2 = Enabled With Code Center 3 = Enabled With Code Center And Bounds

USB CONNECTOR MODELS

PARAMETER	TYPE	SEL	STRING	DATA
CODE COLLECTION				
Code Collection Mode	1	1	<ESC> J A	0 = Within an Image 1 = Within a Phase
Number of Codes	0		<ESC> J B	Range: 1 to 250
Multiple Read	1	1	<ESC> J D	0 = Disabled 1 = Enabled
Code Collection Filters	1	1	<ESC> J C	0 = Disabled 1 = Enabled
Minimum Phase Duration (ms)	0		<ESC> J G	Range: 0 to 65000
CODE FILTER SETTING (DEPTH: n = 1 to 100)				
Status #n	1	1	<ESC> p #n	0 = Disabled 1 = Enabled
Symbology #n	1	1	<ESC> q #n	0 = Interleaved 2 of 5 1 = Code 39 2 = Code 39 Full ASCII 3 = Codabar 4 = Code 128 5 = GS1-128 (ex EAN 128) 6 = Code 93 7 = EAN-13 8 = EAN-8 9 = UPC-A 10 = UPC-E 11 = EAN-13 Addon 2 12 = EAN-8 Addon 2 13 = UPC-A Addon 2 14 = UPC-E Addon 2 15 = EAN-13 Addon 5 16 = EAN-8 Addon 5 17 = UPC-A Addon 5 18 = UPC-E Addon 5 19 = Data Matrix ECC200 20 = PDF417 21 = QR Code 22 = Maxicode 23 = Australia Post 24 = POSTNET 25 = PLANET 26 = Japan Post 27 = KIX Code 28 = Royal Mail 29 = GS1 DataBar Expanded 30 = GS1 DataBar Expanded Stacked 31 = GS1 DataBar Limited 32 = GS1 DataBar

PARAMETER	TYPE	SEL	STRING	DATA
				33 = GS1 DataBar Stacked 34 = Micro PDF417 35 = Code 128 of Composite 36 = CC-A of Composite 37 = CC-B of Composite 38 = CC-C of Composite 39 = GS1 DataBar Expanded of Composite 40 = GS1 DataBar Expanded Stacked of Composite 41 = GS1 DataBar Limited of Composite 42 = GS1 DataBar of Composite 43 = GS1 DataBar Stacked of Composite 44 = Pharmacode 45 = Aztec Code 46 = OCR OCV 47 = Intelligent Mail 48 = Micro QR Code 49 = Swedish Postal 50 = GS1 Data Matrix 51 = Matrix 2 of 5 52 = Standard 2 of 5 53 = MSI 54 = Code 32 55 = Locator Edge
Minimum Number of Characters # <i>n</i>	0		<ESC> r # <i>n</i>	Range: 1 to 3116
Maximum Number of Characters # <i>n</i>	0		<ESC> s # <i>n</i>	Range: 1 to 3116
Code Position Frame: Top # <i>n</i>	0		<ESC> N # <i>n</i>	Range: 0 to 5000
Code Position Frame: Bottom # <i>n</i>	0		<ESC> O # <i>n</i>	Range: 0 to 5000
Code Position Frame: Left # <i>n</i>	0		<ESC> L # <i>n</i>	Range: 0 to 5000
Code Position Frame: Right # <i>n</i>	0		<ESC> M # <i>n</i>	Range: 0 to 5000
Code Quality Index # <i>n</i>	1	1	<ESC> P # <i>n</i>	0 = ISO-IEC / AIM DPM Overall Grade 1 = ISO-IEC Symbol Contrast 2 = ISO-IEC Print Growth 3 = ISO-IEC / AIM DPM Axial Non-Uniformity 4 = ISO-IEC / AIM DPM Unused ECC 5 = ISO-IEC / AIM DPM Decode 6 = ISO-IEC Modulation 7 = ISO-IEC Mean Edge Contrast 8 = ISO-IEC Decodability 9 = ISO-IEC / AIM DPM Fixed Pattern Damage 10 = ISO-IEC / AIM DPM Grid Non-Uniformity 11 = ISO-IEC / AIM DPM Minimum Reflectance 12 = ISO-IEC Defects 13 = AIM DPM Cell Contrast 14 = AIM DPM Cell Modulation 15 = AS9132 Dot Size/Cell Fill

PARAMETER	TYPE	SEL	STRING	DATA
				16 = AS9132 Dot Center Offset 17 = AS9132 Dot Ovality 18 = AS9132 Quiet Zone 19 = AS9132 Symbol Contrast 20 = AS9132 Angle Of Distortion 21 = None
ISO-IEC 16022-18004 Threshold	1	1	<ESC> Q #n	0 = Any Grade 1 = Grade A 2 = Grade B 3 = Grade C 4 = Grade D
ISO-IEC 15415 Threshold	1	1	<ESC> R #n	0 = Any Grade 1 = Grade A 2 = Grade B 3 = Grade C 4 = Grade D
ISO-IEC 15416 Threshold	1	1	<ESC> S #n	0 = Any Grade 1 = Grade A 2 = Grade B 3 = Grade C 4 = Grade D
AIM DPM Threshold	1	1	<ESC> T #n	0 = Any Grade 1 = Grade A 2 = Grade B 3 = Grade C 4 = Grade D
Match Code #n	2		<ESC> w #n	Length: 1 to 3116
Wildcard Character #n	2		<ESC> u #n	Length: 1
Placeholder Character #n	2		<ESC> v #n	Length: 1
Local No-Read Message #n	2		<ESC> t #n	Length: 0 to 64
Local Multiple Read Message #n	2		<ESC> > #n	Length: 0 to 64

 **NOTE** Special characters <FE_H> and <FD_H> must be added after #n in the programming string to indicate parameter **Depth** > 9. Refer to paragraph 3.2 for further details.

PARAMETER	TYPE	SEL	STRING	DATA
DATA FORMAT				
Code Field Justification	1	1	<ESC> K A	0 = Disabled 1 = Left 2 = Right
Code Field Length	0		<ESC> K B	Range: 1 to 3116
Fill Character	2		<ESC> K C	Length: 1
Code Field Cutting	1	1	<ESC> K D	0 = None 1 = Beginning 2 = Middle 3 = End
Separator String	2		<ESC> K E	Length: 1 to 32

PARAMETER	TYPE	SEL	STRING	DATA
(Global) No Read message	2		<ESC> K F	Length: 0 to 64
(Global) Multiple Read message	2		<ESC> J E	Length: 0 to 64
Phase-Overrun Message	2		<ESC> K I	Length: 0 to 16
Data Packet Separator string	2		<ESC> K G	Length: 0 to 32
Data Packet Format (%1, %2, ... are special characters)	2		<ESC> K J	Length: 0 to 128 %1 = Code Identifier %2 = Code Data %3 = Code Center (X-axis) %4 = Code Center (Y-axis) %5 = Code Orientation %6 = Code Quality Index (%) %8 = Image Lighting Quality (%) %A = Code Producer ID %M = Code Data Length %N = Decode Time (ms) %O = Reading Phase Counter %P = Acquisition Counter %_ = Global Diagnostic Status %C = ISO-IEC / AIM DPM Overall (grade) %D = ISO-IEC / AIM DPM Overall (value) %E = ISO-IEC Symbol Contrast / AIM DPM Cell Contrast (grade) %F = ISO-IEC Symbol Contrast AIM DPM Cell Contrast (value) %G = ISO-IEC Print Growth (grade) %H = ISO-IEC Print Growth (value) %I = ISO-IEC / AIM DPM Axial Non-Uniformity (grade) %J = ISO-IEC / AIM DPM Axial Non-Uniformity (value) %K = ISO-IEC / AIM DPM Unused ECC (grade) %L = ISO-IEC / AIM DPM Unused ECC (value) %a = ISO-IEC / AIM DPM Decode (grade) %Q = ISO-IEC Modulation / AIM DPM Cell Modulation (grade) %R = ISO-IEC Modulation / AIM DPM Cell Modulation (value) %S = ISO-IEC Mean Edge Contrast (grade) %T = ISO-IEC Mean Edge Contrast (value) %U = ISO-IEC Decodability (grade) %V = ISO-IEC Decodability (value) %m = ISO-IEC / AIM DPM Fixed Pattern Damage (grade) %W = ISO-IEC / AIM DPM Fixed Pattern Damage (value) %n = ISO-IEC / AIM DPM Grid Non-Uniformity (grade)

PARAMETER	TYPE	SEL	STRING	DATA
				%X = ISO-IEC / AIM DPM Grid Non-Uniformity (value) %o = ISO-IEC / AIM DPM Minimum Reflectance (grade) %Y = ISO-IEC / AIM DPM Minimum Reflectance (value) %p = ISO-IEC Defects (grade) %Z = ISO-IEC Defects (value) %q = AS9132 Dot Size/Cell Fill (grade) %u = AS9132 Dot Size/Cell Fill (value) %r = AS9132 Dot Center Offset (grade) %v = AS9132 Dot Center Offset (value) %s = AS9132 Dot Ovality (Grade) %w = AS9132 Dot Ovality (value) %t = AS9132 Angle Of Distortion (grade) %y = AS9132 Angle Of Distortion (value) %z = AS9132 Quiet Zone (grade) %0 = AS9132 Quiet Zone (value) %b = AS9132 Symbol Contrast (grade) %c = AS9132 Symbol Contrast (value) %* = Data Matrix Setting Information
Statistics Field Separator String	2		<ESC> K H	Length: 0 to 32
Statistics Field Format (%1, %2, ... are special characters)	2		<ESC> K S	Length: 0 to 128 %0 = Phase or Acquisition Counter to WebSentinel %1 = Phase Overrun Message %2 = Phase or Acquisition Counter %3 = No Read Counter %4 = Partial Read Counter %5 = Complete Read Counter %6 = Right Code Counter (Match Code enabled) %7 = Wrong Code Counter (Match Code enabled) %8 = Multiple Read Counter %! = Image Processing Time (ms)
Symbology Identifiers	1	1	<ESC> K K	0 = Disabled 1 = Enabled

SYMBOLOGY IDENTIFIERS

Data Matrix ECC200	2		<ESC> L A	Length: 0 to 32
GS1 Data Matrix	2		<ESC> L >	Length: 0 to 32
QR Code	2		<ESC> L C	Length: 0 to 32
Aztec Code	2		<ESC> L D	Length: 0 to 32
Maxicode	2		<ESC> L E	Length: 0 to 32
PDF417	2		<ESC> L B	Length: 0 to 32
Micro PDF417	2		<ESC> L y	Length: 0 to 32
Interleaved 2 of 5	2		<ESC> L X	Length: 0 to 32
Code 39	2		<ESC> L V	Length: 0 to 32
Code 39 Full ASCII	2		<ESC> L W	Length: 0 to 32
Codabar	2		<ESC> L v	Length: 0 to 32
Code 128	2		<ESC> L T	Length: 0 to 32
GS1-128 (ex EAN 128)	2		<ESC> L U	Length: 0 to 32
Code 93	2		<ESC> L w	Length: 0 to 32
EAN-13	2		<ESC> L e	Length: 0 to 32
EAN-8	2		<ESC> L f	Length: 0 to 32

PARAMETER	TYPE	SEL	STRING	DATA
UPC-A	2		<ESC> L g	Length: 0 to 32
UPC-E	2		<ESC> L h	Length: 0 to 32
EAN-13 AddOn 2	2		<ESC> L i	Length: 0 to 32
EAN-8 AddOn 2	2		<ESC> L j	Length: 0 to 32
UPC-A AddOn 2	2		<ESC> L k	Length: 0 to 32
UPC-E AddOn 2	2		<ESC> L m	Length: 0 to 32
EAN-13 AddOn 5	2		<ESC> L n	Length: 0 to 32
EAN-8 AddOn 5	2		<ESC> L o	Length: 0 to 32
UPC-A AddOn 5	2		<ESC> L p	Length: 0 to 32
UPC-E AddOn 5	2		<ESC> L q	Length: 0 to 32
Australia Post	2		<ESC> L F	Length: 0 to 32
PostNet	2		<ESC> L G	Length: 0 to 32
Planet	2		<ESC> L H	Length: 0 to 32
Japan Post	2		<ESC> L I	Length: 0 to 32
KIX Code	2		<ESC> L J	Length: 0 to 32
Royal Mail 4 State	2		<ESC> L K	Length: 0 to 32
Intelligent Mail	2		<ESC> L Y	Length: 0 to 32
Swedish Postal	2		<ESC> L ?	Length: 0 to 32
GS1 DataBar Expanded	2		<ESC> L r	Length: 0 to 32
GS1 DataBar Expanded Stacked	2		<ESC> L x	Length: 0 to 32
GS1 DataBar Limited	2		<ESC> L s	Length: 0 to 32
GS1 DataBar	2		<ESC> L t	Length: 0 to 32
GS1 DataBar Stacked	2		<ESC> L u	Length: 0 to 32
Code 128 of Composite	2		<ESC> L L	Length: 0 to 32
GS1 DataBar Expanded of Composite	2		<ESC> L M	Length: 0 to 32
GS1 DataBar Expanded Stacked of Composite	2		<ESC> L z	Length: 0 to 32
GS1 DataBar Limited of Composite	2		<ESC> L N	Length: 0 to 32
GS1 DataBar of Composite	2		<ESC> L O	Length: 0 to 32
GS1 DataBar Stacked of Composite	2		<ESC> L P	Length: 0 to 32
CC-A of Composite	2		<ESC> L Q	Length: 0 to 32
CC-B of Composite	2		<ESC> L R	Length: 0 to 32
CC-C of Composite	2		<ESC> L S	Length: 0 to 32
Pharmacode	2		<ESC> L a	Length: 0 to 32
MSI	2		<ESC> L <	Length: 0 to 32
Standard 2 of 5	2		<ESC> L -	Length: 0 to 32
Matrix 2 of 5	2		<ESC> L [Length: 0 to 32
Code 32	2		<ESC> L _	Length: 0 to 32
DATA TRANSMISSION				
Partial Read TX	1	1	<ESC> K L	0 = Disabled 1 = Enabled
Message TX Selection	1	1	<ESC> K M	0 = On Complete Read 1 = After Reading Phase OFF 2 = Delayed TX Line
Conveyor Speed (mm/sec)	0		<ESC> K V	Range: 50 to 10000
Delayed TX Line Distance (mm)	0		<ESC> K Z	Range: 100 to 20000

PARAMETER	TYPE	SEL	STRING	DATA
STATISTICS				
Status	1	1	<ESC> K O	0 = Disabled 1 = Enabled
Number of Samples	0		<ESC> K P	Range: 5 to 1000
Output Format	1	1	<ESC> K Q	0 = % (on Last Samples) 1 = N/M (on Last Samples) 2 = %+N/M (on Last Samples) 3 = % (on All Samples) 4 = N/M (on All Samples) 5 = %+N/M (on All Samples)
Last Read Code TX	1	1	<ESC> K R	0 = Disabled 1 = Enabled 2 = Enabled With Code Center 3 = Enabled With Code Center And Bounds

4.15 DIGITAL I/O

25 PIN CONNECTOR MODELS ETHERNET MODELS

PARAMETER	TYPE	SEL	STRING	DATA
EXTERNAL TRIGGER				
Active State	1	1	<ESC> M A	0 = Closed 1 = Open
Debounce Filter (ms)	1	1	<ESC> M B	0 = 0.5 1 = 1 2 = 5 3 = 10 4 = 0.1
INPUT 2				
Active State	1	1	<ESC> M C	0 = Closed 1 = Open
Debounce Filter (ms)	1	1	<ESC> M D	0 = 0.5 1 = 1 2 = 5 3 = 10 4 = 0.1
OUTPUT 1				
Line Function	1	1	<ESC> O a	0 = Standard 1 = External Lighting System 2 = External Fieldbus 3 = External Host Command
Line State	1	1	<ESC> O A	0 = Normally Open 1 = Normally Closed
Activation Events (Match Code disabled)	3	28	<ESC> O B	0 = None 1 = Complete Read 2 = Partial Read 4 = No Read 8 = Acquisition Trigger 16 = Phase ON 32 = Phase OFF

PARAMETER	TYPE	SEL	STRING	DATA
				64 = Run Mode 128 = Host Control Mode 256 = ISO-IEC Symbol Contrast 512 = ISO-IEC Print Growth 1024 = ISO-IEC / AIM DPM Axial Non-Uniformity 2048 = ISO-IEC / AIM DPM Unused ECC 4096 = ISO-IEC Modulation 8192 = ISO-IEC Mean Edge Contrast 16384 = ISO-IEC Decodability 32576 = ISO-IEC / AIM DPM Fixed Pattern Damage 65536 = ISO-IEC / AIM DPM Grid Non-Uniformity 131072 = ISO-IEC / AIM DPM Minimum Reflectance 262144 = ISO-IEC Defects 524288 = ISO-IEC / AIM DPM Decode 1048576 = AIM DPM Cell Contrast 2097152 = AIM DPM Cell Modulation 4194304 = AS9132 Dot Size/Cell Fill 8388608 = AS9132 Dot Center Offset 16777216 = AS9132 Dot Ovality 33554432 = AS9132 Quiet Zone 67108864 = AS9132 Angle Of Distortion 134217728 = AS9132 Symbol Contrast 268435456 = Multiple Read
Activation Events (Match Code enabled)	3	28	<ESC> O C	0 = None 1 = Right Code 2 = Wrong Code 4 = No Read 8 = Acquisition Trigger 16 = Phase ON 32 = Phase OFF 64 = Run Mode 128 = Host Control Mode 256 = ISO-IEC Symbol Contrast 512 = ISO-IEC Print Growth 1024 = ISO-IEC / AIM DPM Axial Non-Uniformity 2048 = ISO-IEC / AIM DPM Unused ECC 4096 = ISO-IEC Modulation 8192 = ISO-IEC Mean Edge Contrast 16384 = ISO-IEC Decodability 32576 = ISO-IEC / AIM DPM Fixed Pattern Damage 65536 = ISO-IEC / AIM DPM Grid Non-Uniformity 131072 = ISO-IEC / AIM DPM Minimum Reflectance 262144 = ISO-IEC Defects 524288 = ISO-IEC / AIM DPM Decode 1048576 = AIM DPM Cell Contrast 2097152 = AIM DPM Cell Modulation 4194304 = AS9132 Dot Size/Cell Fill 8388608 = AS9132 Dot Center Offset 16777216 = AS9132 Dot Ovality

PARAMETER	TYPE	SEL	STRING	DATA
				33554432 = AS9132 Quiet Zone 67108864 = AS9132 Angle Of Distortion 134217728 = AS9132 Symbol Contrast
Additional Activation Events	3	1	<ESC> O -	0 = None 1 = External Host Command 2 = OCR Read 4 = 2D Read
ISO-IEC 16022-18004 Threshold	1	1	<ESC> O D	0 = Grade A 1 = Grade B 2 = Grade C 3 = Grade D
ISO-IEC 15415 Threshold	1	1	<ESC> O b	0 = Grade A 1 = Grade B 2 = Grade C 3 = Grade D
ISO-IEC 15416 Threshold	1	1	<ESC> O c	0 = Grade A 1 = Grade B 2 = Grade C 3 = Grade D
AIM DPM Threshold	1	1	<ESC> O i	0 = Grade A 1 = Grade B 2 = Grade C 3 = Grade D
Number Of Events	0		<ESC> O E	Range: 1 to 255
Number of Reading Phases	0		<ESC> O F	Range: 1 to 255
Deactivation Events	3	4	<ESC> O G	0 = None 1 = Timeout 2 = Acquisition Trigger 4 = Phase ON 8 = Phase OFF
Deactivation Timeout (ms)	0		<ESC> O H	Range: 1 to 15000
Activate On Any Diagnostics Error	1	1	<ESC> O I	0 = Disabled 1 = Enabled
Deactivate When All Errors Recovered	1	1	<ESC> O m	0 = Disabled 1 = Enabled
Activate On Trend Analysis	1	1	<ESC> O n	0 = Disabled 1 = Enabled
Reading Rate Threshold (%)	0		<ESC> O p	Range: 0 to 100
Pulsed Activation Period (sec)	0		<ESC> O q	Range: 0 to 180 (0 = Disabled)
Deactivate When Trend Recovered	1	1	<ESC> O r	0 = Disabled 1 = Enabled
OUTPUT 2				
Line Function	1	1	<ESC> O d	0 = Standard 1 = External Lighting System 2 = External Fieldbus 3 = External Host Command
Line State	1	1	<ESC> O I	0 = Normally Open 1 = Normally Closed
Activation Events (Match Code disabled)	3	28	<ESC> O J	0 = None 1 = Complete Read 2 = Partial Read 4 = No Read 8 = Acquisition Trigger

PARAMETER	TYPE	SEL	STRING	DATA
				16 = Phase ON 32 = Phase OFF 64 = Run Mode 128 = Host Control Mode 256 = ISO-IEC Symbol Contrast 512 = ISO-IEC Print Growth 1024 = ISO-IEC / AIM DPM Axial Non-Uniformity 2048 = ISO-IEC / AIM DPM Unused ECC 4096 = ISO-IEC Modulation 8192 = ISO-IEC Mean Edge Contrast 16384 = ISO-IEC Decodability 32576 = ISO-IEC / AIM DPM Fixed Pattern Damage 65536 = ISO-IEC / AIM DPM Grid Non-Uniformity 131072 = ISO-IEC / AIM DPM Minimum Reflectance 262144 = ISO-IEC Defects 524288 = ISO-IEC / AIM DPM Decode 1048576 = AIM DPM Cell Contrast 2097152 = AIM DPM Cell Modulation 4194304 = AS9132 Dot Size/Cell Fill 8388608 = AS9132 Dot Center Offset 16777216 = AS9132 Dot Ovality 33554432 = AS9132 Quiet Zone 67108864 = AS9132 Angle Of Distortion 134217728 = AS9132 Symbol Contrast 268435456 = Multiple Read
Activation Events (Match Code enabled)	3	28	<ESC> O K	0 = None 1 = Right Code 2 = Wrong Code 4 = No Read 8 = Acquisition Trigger 16 = Phase ON 32 = Phase OFF 64 = Run Mode 128 = Host Control Mode 256 = ISO-IEC Symbol Contrast 512 = ISO-IEC Print Growth 1024 = ISO-IEC / AIM DPM Axial Non-Uniformity 2048 = ISO-IEC / AIM DPM Unused ECC 4096 = ISO-IEC Modulation 8192 = ISO-IEC Mean Edge Contrast 16384 = ISO-IEC Decodability 32576 = ISO-IEC / AIM DPM Fixed Pattern Damage 65536 = ISO-IEC / AIM DPM Grid Non-Uniformity 131072 = ISO-IEC / AIM DPM Minimum Reflectance 262144 = ISO-IEC Defects 524288 = ISO-IEC / AIM DPM Decode 1048576 = AIM DPM Cell Contrast 2097152 = AIM DPM Cell Modulation 4194304 = AS9132 Dot Size/Cell Fill

PARAMETER	TYPE	SEL	STRING	DATA
				8388608 = AS9132 Dot Center Offset 16777216 = AS9132 Dot Ovality 33554432 = AS9132 Quiet Zone 67108864 = AS9132 Angle Of Distortion 134217728 = AS9132 Symbol Contrast
Additional Activation Events	3	1	<ESC> O _	0 = None 1 = External Host Command 2 = OCR Read 4 = 2D Read
ISO-IEC 16022-18004 Threshold	1	1	<ESC> O L	0 = Grade A 1 = Grade B 2 = Grade C 3 = Grade D
ISO-IEC 15415 Threshold	1	1	<ESC> O e	0 = Grade A 1 = Grade B 2 = Grade C 3 = Grade D
ISO-IEC 15416 Threshold	1	1	<ESC> O f	0 = Grade A 1 = Grade B 2 = Grade C 3 = Grade D
AIM DPM Threshold	1	1	<ESC> O j	0 = Grade A 1 = Grade B 2 = Grade C 3 = Grade D
Number Of Events	0		<ESC> O M	Range: 1 to 255
Number of Reading Phases	0		<ESC> O N	Range: 1 to 255
Deactivation Events	3	4	<ESC> O P	0 = None 1 = Timeout 2 = Acquisition Trigger 4 = Phase ON 8 = Phase OFF
Deactivation Timeout (ms)	0		<ESC> O Q	Range: 1 to 15000
Activate On Any Diagnostics Error	1	1	<ESC> O s	0 = Disabled 1 = Enabled
Deactivate When All Errors Recovered	1	1	<ESC> O t	0 = Disabled 1 = Enabled
Activate On Trend Analysis	1	1	<ESC> O u	0 = Disabled 1 = Enabled
Reading Rate Threshold (%)	0		<ESC> O v	Range: 0 to 100
Pulsed Activation Period (sec)	0		<ESC> O w	Range: 0 to 180 (0 = Disabled)
Deactivate When Trend Recovered	1	1	<ESC> O x	0 = Disabled 1 = Enabled

4.16 LEADS AND KEYPAD

PARAMETER	TYPE	SEL	STRING	DATA
KEYPAD				
Status	1	1	<ESC> N A	0 = Disabled 1 = Enabled

PARAMETER	TYPE	SEL	STRING	DATA
Button Function 1 (a) not for USB models	1	1	<ESC> N G	0 = Disabled 1 = Autolearning 2 = Calibration Only 3 = Code Setting Only 4 = Positioning 5 = Restore Default 6 = Test Mode 7 = Locate 8 = Store Match Code 9 = Enable DHCP (a)
Button Function 2 (a) not for USB models	1	1	<ESC> N H	0 = Disabled 1 = Autolearning 2 = Calibration Only 3 = Code Setting Only 4 = Positioning 5 = Restore Default 6 = Test Mode 7 = Locate 8 = Store Match Code 9 = Enable DHCP (a)
Button Function 3 (a) not for USB models	1	1	<ESC> N I	0 = Disabled 1 = Autolearning 2 = Calibration Only 3 = Code Setting Only 4 = Positioning 5 = Restore Default 6 = Test Mode 7 = Locate 8 = Store Match Code 9 = Enable DHCP (a)
Button Function 4 (a) not for USB models	1	1	<ESC> N U	0 = Disabled 1 = Autolearning 2 = Calibration Only 3 = Code Setting Only 4 = Positioning 5 = Restore Default 6 = Test Mode 7 = Locate 8 = Store Match Code 9 = Enable DHCP (a)
LEDS				
Green Spot Activation Events (Match Code disabled)	3	4	<ESC> N W	0 = None 1 = Decoding 2 = Complete Read 4 = Partial Read 8 = No Read 16 = Multiple Read
Green Spot Activation Events (Match Code enabled)	3	4	<ESC> N X	0 = None 1 = Decoding 2 = Right Code 4 = Wrong Code 8 = No Read
Green Spot Deactivation Timeout (sec)	0		<ESC> N Y	Range: 1 to 300 (0 = Disabled)
COM LED Function	1	1	<ESC> N C	0 = Main Serial Port RX 1 = Main Serial Port TX

PARAMETER	TYPE	SEL	STRING	DATA
Aiming System Status	1	1	<ESC> N Z	0 = Disabled 1 = Enabled
LEDs Deactivation Timeout (sec)	0		<ESC> N V	Range: 0 to 300
Partial Read Treated As	1	1	<ESC> N a	0 = No Read 1 = Complete Read
Multiple Read Treated As	1	1	<ESC> N f	0 = No Read 1 = Complete Read
BEEPER				
Status	1	1	<ESC> N T	0 = Disabled 1 = Enabled
Activation Events (Match Code disabled)	3	4	<ESC> N D	0 = None 1 = Decoding 2 = Complete Read 4 = Partial Read 8 = No Read 16 = Multiple Read
Activation Events (Match Code enabled)	3	4	<ESC> N E	0 = None 1 = Decoding 2 = Right Code 4 = Wrong Code 8 = No Read
Deactivation Timeout (ms)	0		<ESC> N F	Range: 1 to 1500
TEST MODE SETUP				
Image Acquisition Setting	0		<ESC> N b	Range: 1 to 10
Number Of Samples	0		<ESC> N c	Range: 5 to 1000
Test Mode Data TX	3	3	<ESC> N d	0 = None 1 = Auxiliary Port 2 = Main Port 4 = ID-NET 8 = Host Interface Port
Test Mode Exit Timeout (sec)	0		<ESC> N e	Range: 1 to 300 (0 = Disabled)
AUTOLEARNING SETUP (X-PRESS™)				
Image Acquisition Setting	0		<ESC> N J	Range: 1 to 10
Calibration Mode	1	1	<ESC> N K	0 = Gain Only 1 = Exposure Time Only 2 = Exposure Time And Gain
Code Setting Mode	1	1	<ESC> N L	0 = General Purpose 1 = 2D Codes Only 2 = 1D Codes Only 3 = Direct Marking Only 4 = 1D And 2D Only
Add New Symbology	1	1	<ESC> N M	0 = Disabled 1 = Enabled
Store Memory	1	1	<ESC> N B	0 = Temporary 1 = Permanent
Store Match Code Policy	1	1	<ESC> N z	0 = First Free Slot 1 = First Slot
Autolearning Timeout (sec)	0		<ESC> N O	Range: 1 to 300 (0 = Disabled)

PARAMETER	TYPE	SEL	STRING	DATA
POSITIONING SETUP				
Image Acquisition Setting	0		<ESC> N P	Range: 1 to 10
Positioning Mode	1	1	<ESC> N Q	0 = Standard 1 = Accurate
Positioning Tolerance (mm)	0		<ESC> N R	Range: 1 to 1000
Positioning Timeout (sec)	0		<ESC> N S	Range: 1 to 300 (0 = Disabled)

4.17 DISPLAY

25 PIN CONNECTOR MODELS + CBX DISPLAY MODULE ETHERNET MODELS + CBX DISPLAY MODULE

PARAMETER	TYPE	SEL	STRING	DATA
DISPLAY				
Display Language	1	1	<ESC> U A	0 = English (United States) 1 = French (France) 2 = German (Germany) 3 = Italian (Italy) 4 = Japanese (Japan)
Layout Monitor	1	1	<ESC> U B	0 = Reading Mask Only 1 = Reading Mask / Device State

4.18 DIAGNOSTICS

25 PIN CONNECTOR MODELS ETHERNET MODELS

PARAMETER	TYPE	SEL	STRING	DATA
HEARTBEAT				
Status	1	1	<ESC> T k	0 = Disabled 1 = Enabled
DIAGNOSTICS				
Status	1	1	<ESC> T A	0 = Disabled 1 = Enabled
Refresh Time (sec)	1	1	<ESC> T B	0 = 1 1 = 2 2 = 5 3 = 10 4 = 30 5 = 60
Slave Diagnostics (Master/Slave)	1	1	<ESC> T C	0 = Disabled 1 = Enabled
Slave Diagnostics (ID-NET Network)	1	1	<ESC> T D	0 = Disabled 1 = Enabled
Local Network Failure	1	1	<ESC> T E	0 = Disabled 1 = Enabled

PARAMETER	TYPE	SEL	STRING	DATA
LEDs Activation On Slave Failure (Master/Slave)	1	1	<ESC> T F	0 = Disabled 1 = Enabled
LEDs Activation On Slave Failure (ID-NET Network)	1	1	<ESC> T G	0 = Disabled 1 = Enabled
Fieldbus Communication Failure	1	1	<ESC> T H	0 = Disabled 1 = Enabled
Fieldbus Type Mismatch	1	1	<ESC> T I	0 = Disabled 1 = Enabled
Fieldbus Configuration Error	1	1	<ESC> T J	0 = Disabled 1 = Enabled
Fieldbus DHCP Problem			<ESC> T K	
Wrong Rotary Switch Selection	1	1	<ESC> T L	0 = Disabled 1 = Enabled
CBX BM100 Communication Failure	1	1	<ESC> T M	0 = Disabled 1 = Enabled
ACTIONS				
Heartbeat TX Mode	1	1	<ESC> T I	0 = Conditioned 1 = Unconditioned
Heartbeat TX Timeout (sec)	1	1	<ESC> T m	0 = 1 1 = 2 2 = 5 3 = 10 4 = 30 5 = 60 6 = 180
TX Mode	1	1	<ESC> T Q	0 = On Timeout 1 = With Code
Message Position	1	1	<ESC> T R	0 = Append to Code 1 = Replace Code
TX Refresh Timeout (sec)	1	1	<ESC> T S	0 = 1 1 = 2 2 = 5 3 = 10 4 = 30 5 = 60 6 = 180
Auxiliary Port	1	1	<ESC> T T	0 = Disabled 1 = Enabled
Main Port	1	1	<ESC> T U	0 = Disabled 1 = Enabled
Fieldbus Port	1	1	<ESC> T V	0 = Disabled 1 = Enabled
Ethernet Data Socket	1	1	<ESC> T W	0 = Disabled 1 = Enabled
Ethernet Modbus Socket	1	1	<ESC> T g	0 = Disabled 1 = Enabled
Ethernet Ethernet/IP Socket	1	1	<ESC> T i	0 = Disabled 1 = Enabled
CBX Ethernet Data Socket	1	1	<ESC> T k	0 = Disabled 1 = Enabled
CBX Ethernet Modbus Socket	1	1	<ESC> T h	0 = Disabled 1 = Enabled

PARAMETER	TYPE	SEL	STRING	DATA
CBX Ethernet Ethernet/IP Socket	1	1	<ESC> T j	0 = Disabled 1 = Enabled
FORMAT				
Header String	2		<ESC> T X	Length: 0 to 128
Terminator String	2		<ESC> T Y	Length: 0 to 128
Heartbeat Message Format	1	1	<ESC> T n	0 = Internal Numeric Messages 1 = User Defined Messages
Diagnostics Message Format	1	1	<ESC> T Z	0 = Internal Numeric Messages 1 = User Defined Messages
Heartbeat Add Node Address	1	1	<ESC> T p	0 = Disabled 1 = Enabled
USER DEFINED MESSAGES				
Slave No Reply	2		<ESC> T a	Length: 0 to 128
Slave Address Duplication	2		<ESC> T b	Length: 0 to 128
Slave Net Configuration	2		<ESC> T c	Length: 0 to 128
Local Network Failure	2		<ESC> T d	Length: 0 to 128
Fieldbus Communication Failure	2		<ESC> T e	Length: 0 to 128
Fieldbus Type Mismatch	2		<ESC> T f	Length: 0 to 128
Fieldbus Configuration Error	2		<ESC> T g	Length: 0 to 128
Fieldbus DHCP Problem	2		<ESC> T h	Length: 0 to 128
Wrong Rotary Switch Selection	2		<ESC> T i	Length: 0 to 128
CBX BM100 Communication Failure	2		<ESC> T j	Length: 0 to 128
Hearbeat Message	2		<ESC> T o	Length: 0 to 128

USB CONNECTOR MODELS

PARAMETER	TYPE	SEL	STRING	DATA
HEARTBEAT				
Status	1	1	<ESC> T k	0 = Disabled 1 = Enabled
ACTIONS				
Heartbeat TX Mode	1	1	<ESC> T l	0 = Conditioned 1 = Unconditioned
Heartbeat TX Timeout (sec)	1	1	<ESC> T m	0 = 1 1 = 2 2 = 5 3 = 10 4 = 30 5 = 60 6 = 180
Main Port	1	1	<ESC> T U	0 = Disabled 1 = Enabled
FORMAT				
Header String	2		<ESC> T X	Length: 0 to 128

PARAMETER	TYPE	SEL	STRING	DATA
Terminator String	2		<ESC> T Y	Length: 0 to 128
Heartbeat Message Format	1	1	<ESC> T n	0 = Internal Numeric Messages 1 = User Defined Messages
USER DEFINED MESSAGES				
Hearbeat Message	2		<ESC> T o	Length: 0 to 128

4.19 MATCH CODE

25 PIN CONNECTOR MODELS ETHERNET MODELS

PARAMETER	TYPE	SEL	STRING	DATA
MATCH CODE				
Status	1	1	<ESC> P A	0 = Disabled 1 = Enabled
Symbology Check	1	1	<ESC> P B	0 = Disabled 1 = Enabled
Store Input	3	2	<ESC> P C	0 = None 1 = External Trigger 2 = Input 2
Right Code Message	2		<ESC> P D	Length: 0 to 64
Wrong Code Message	2		<ESC> P E	Length: 0 to 64
Store Memory	1	1	<ESC> P F	0 = Temporary 1 = Permanent
MATCH CODE SLOT (DEPTH: n = 1 to 10)				
Symbology #n	1	1	<ESC> y #n	0 = Interleaved 2 of 5 1 = Code 39 2 = Code 39 Full ASCII 3 = Codabar 4 = Code 128 5 = GS1-128 (ex EAN 128) 6 = Code 93 7 = EAN-13 8 = EAN-8 9 = UPC-A 10 = UPC-E 11 = EAN-13 AddOn 2 12 = EAN-8 AddOn 2 13 = UPC-A AddOn 2 14 = UPC-E AddOn 2 15 = EAN-13 AddOn 5 16 = EAN-8 AddOn 5 17 = UPC-A AddOn 5 18 = UPC-E AddOn 5 19 = Data Matrix ECC200 20 = PDF417 21 = QR Code 22 = Maxicode 23 = Australia Post 24 = POSTNET 25 = PLANET 26 = Japan Post

PARAMETER	TYPE	SEL	STRING	DATA
				27 = KIX Code 28 = Royal Mail 29 = GS1 DataBar Expanded 30 = GS1 DataBar Expanded Stacked 31 = GS1 DataBar Limited 32 = GS1 DataBar 33 = GS1 DataBar Stacked 34 = Micro PDF417 35 = Code 128 of Composite 36 = CC-A of Composite 37 = CC-B of Composite 38 = CC-C of Composite 39 = GS1 DataBar Expanded of Composite 40 = GS1 DataBar Expanded Stacked of Composite 41 = GS1 DataBar Limited of Composite 42 = GS1 DataBar of Composite 43 = GS1 DataBar Stacked of Composite 44 = Pharmacode 45 = Aztec Code 46 = OCR OCV 47 = Intelligent Mail 48 = Micro QR Code 49 = Swedish Postal 50 = GS1 Data Matrix 51 = Matrix 2 of 5 52 = Standard 2 of 5 53 = MSI 54 = Code 32 55 = Locator Edge
Data # <i>n</i>	2		<ESC> z # <i>n</i>	Length: 0 to 3116
Wildcard Character # <i>n</i>	2		<ESC> Y # <i>n</i>	Length: 1
Placeholder Character # <i>n</i>	2		<ESC> Z # <i>n</i>	Length: 1

**NOTE**

Special characters <FE_H> and <FD_H> must be added after #*n* in the programming string to indicate parameter **Depth** > 9. Refer to paragraph 3.2 for further details.

USB CONNECTOR MODELS

PARAMETER	TYPE	SEL	STRING	DATA
MATCH CODE				
Status	1	1	<ESC> P A	0 = Disabled 1 = Enabled
Symbology Check	1	1	<ESC> P B	0 = Disabled 1 = Enabled
Right Code Message	2		<ESC> P D	Length: 0 to 64
Wrong Code Message	2		<ESC> P E	Length: 0 to 64

PARAMETER	TYPE	SEL	STRING	DATA
MATCH CODE SLOT (DEPTH: n = 1 to 10)				
Symbology #n	1	1	<ESC> y #n	0 = Interleaved 2 of 5 1 = Code 39 2 = Code 39 Full ASCII 3 = Codabar 4 = Code 128 5 = GS1-128 (ex EAN 128) 6 = Code 93 7 = EAN-13 8 = EAN-8 9 = UPC-A 10 = UPC-E 11 = EAN-13 AddOn 2 12 = EAN-8 AddOn 2 13 = UPC-A AddOn 2 14 = UPC-E AddOn 2 15 = EAN-13 AddOn 5 16 = EAN-8 AddOn 5 17 = UPC-A AddOn 5 18 = UPC-E AddOn 5 19 = Data Matrix ECC200 20 = PDF417 21 = QR Code 22 = Maxicode 23 = Australia Post 24 = POSTNET 25 = PLANET 26 = Japan Post 27 = KIX Code 28 = Royal Mail 29 = GS1 DataBar Expanded 30 = GS1 DataBar Expanded Stacked 31 = GS1 DataBar Limited 32 = GS1 DataBar 33 = GS1 DataBar Stacked 34 = Micro PDF417 35 = Code 128 of Composite 36 = CC-A of Composite 37 = CC-B of Composite 38 = CC-C of Composite 39 = GS1 DataBar Expanded of Composite 40 = GS1 DataBar Expanded Stacked of Composite 41 = GS1 DataBar Limited of Composite 42 = GS1 DataBar of Composite 43 = GS1 DataBar Stacked of Composite 44 = Pharmacode 45 = Aztec Code 46 = OCR OCV 47 = Intelligent Mail 48 = Micro QR Code 49 = Swedish Postal 50 = GS1 Data Matrix 51 = Matrix 2 of 5 52 = Standard 2 of 5 53 = MSI

PARAMETER	TYPE	SEL	STRING	DATA
				54 = Code 32 55 = Locator Edge
Data # <i>n</i>	2		<ESC> z # <i>n</i>	Length: 0 to 3116
Wildcard Character # <i>n</i>	2		<ESC> Y # <i>n</i>	Length: 1
Placeholder Character # <i>n</i>	2		<ESC> Z # <i>n</i>	Length: 1

**NOTE**

Special characters <FE_H> and <FD_H> must be added after #*n* in the programming string to indicate parameter **Depth** > 9. Refer to paragraph 3.2 for further details.

4.20 SYMBOL VERIFICATION

PARAMETER	TYPE	SEL	STRING	DATA
ISO-IEC 16022-18004				
Status	1	1	<ESC> R A	0 = Disabled 1 = Enabled
ISO-IEC 15415-15416 SETUP				
Aperture Mode	1	1	<ESC> R B	0 = Automatic 1 = Custom
Aperture (mils)	0		<ESC> R C	Range: 0 to 1000
Angle	0		<ESC> R D	Range: 0 to 90
Light Wavelength (nm)	1	1	<ESC> R E	0 = White 1 = 660 2 = 760
ISO-IEC 15415				
Status	1	1	<ESC> R F	0 = Disabled 1 = Enabled
ISO-IEC 15416				
Status	1	1	<ESC> R G	0 = Disabled 1 = Enabled
Grade Type	1	1	<ESC> R H	0 = 10 Scans 1 = Media 2 = Media & 10 Scans
AS9132A				
Status	1	1	<ESC> R I	0 = Disabled 1 = Enabled
PARAMETER				
Module Shape	1	1	<ESC> R J	0 = Dot 1 = Square
Marking Method	1		<ESC> R K	0 = Laser/Chemical 1 = Inkjet/Dot Peen

PARAMETER	TYPE	SEL	STRING	DATA
AIM DPM SETUP				
Aperture Mode	1	1	<ESC> R L	0 = Automatic 1 = Custom
Aperture (mils)	0		<ESC> R M	Range: 0 to 1000
Lighting	1	1	<ESC> R N	0 = 90 1 = D 2 = 30Q 3 = 30T 4 = 30S 5 = 45Q
Light Wavelength (nm)	1	1	<ESC> R O	0 = White 1 = 660 2 = 760
AIM DPM				
Status	1	1	<ESC> R P	0 = Disabled 1 = Enabled

4.21 MISCELLANEOUS

PARAMETER	TYPE	SEL	STRING	DATA
READER INFORMATION				
Reader Name	2		<ESC> Q A	Length: 3 to 32
User Name	2		<ESC> Q O	Length: 0 to 128
Line Name	2		<ESC> Q P	Length: 0 to 128
IMAGE BUFFER				
Status	1	1	<ESC> Q G	0 = Disabled 1 = Enabled
Saving Event (One Shot, Continuous)	4	5	<ESC> Q H	1 = Complete Read 2 = Partial Read 4 = No Read 8 = Right Code 16 = Wrong Code 32 = Multiple Read 64 = Decoded But Not Collected
Saving Event (Phase Mode, Code Collection = Within An Image)	4	5	<ESC> Q I	1 = Complete Read 2 = Partial Read 4 = No Read 8 = Right Code 16 = Wrong Code 32 = Multiple Read 64 = Decoded But Not Collected
Saving Event (Phase Mode, Code Collection = Within A Phase)	4	2	<ESC> Q J	1 = Successful Decoding 2 = Decoding Failure 4 = Decoded But Not Collected
Max Number Of Images In Buffer	0		<ESC> Q K	Range: 1 to 5000
Image Subsampling	1	1	<ESC> Q L	0 = 1/1 1 = 1/4 2 = 1/16 3 = 1/64

PARAMETER	TYPE	SEL	STRING	DATA
Image Format	1	1	<ESC> Q M	0 = BMP 1 = JPG 2 = TIFF 3 = RAW
JPG Quality (1-100)	0		<ESC> Q N	Range: 1 to 100
VISASET IMAGE SAVING				
Download Event	1	1	<ESC> Q B	0 = Disabled 1 = Enabled on Successful Decoding 2 = Enabled on Decoding Failure 3 = Always Enabled
Image Format	1	1	<ESC> Q C	0 = BMP 1 = JPG 2 = TIFF 3 = RAW
Image Subsampling	1	1	<ESC> Q W	0 = 1/1 1 = 1/4 2 = 1/16 3 = 1/64
JPG Quality (1-100)	0		<ESC> Q D	Range: 1 to 100
Image Absolute Path	2		<ESC> Q E	Length: 1 to 64
Max Number Of Images Saved	0		<ESC> Q F	Range: 1 to 1000000

4.22 OCR OCV

(Requires OCR License)

PARAMETER	TYPE	SEL	STRING	DATA
OCR OCV				
Status	1	1	<ESC> z a	0 = Disabled 1 = Enabled
OCR Type Configuration (READ ONLY !!!)	1	1	<ESC> z b	0 = None 1 = Absolute ROI 2 = Localized by Blob 3 = Localized by Code 4 = Localized by Edge 8 = Code Localization Failure
Show All OCR ROIs	1	1	<ESC> z e	0 = Disabled 1 = Enabled
Show Font Statistics	1	1	<ESC> z f	0 = Disabled 1 = Enabled
Match String Constraints	1	1	<ESC> z g	0 = None 1 = Sub-String 2 = Code String
Localization by Code	1	1	<ESC> z c	0 = Disabled 1 = Enabled
Code-OCR Offset	0		<ESC> z d	Range: 0 to 359
Enable Fielding	1	1	<ESC> z h	0 = Disabled 1 = Enabled

PARAMETER	TYPE	SEL	STRING	DATA
OCR CONFIGURATION (DEPTH: n = 1 to 10)				
OCR Match String #n	2		<ESC> w e #n	Length: 1 to 256
Quality Level #n	0		<ESC> w q #n	Range: 0 to 1000
ROI CONFIGURATION (DEPTH: n = 1 to 10)				
Top Left Corner Row #n	0		<ESC> w a #n	Range: 0 to 2048
Top Left Corner Column #n	0		<ESC> w b #n	Range: 0 to 2048
Bottom Right Corner Row #n	0		<ESC> w c #n	Range: 0 to 2048
Bottom Right Corner Column #n	0		<ESC> w d #n	Range: 0 to 2048
EDGE CONFIGURATION (DEPTH: n = 1 to 10)				
Edge Sensitivity #n	0		<ESC> w r #n	Range: 0 to 100
Edge Noise Rejection #n	0		<ESC> w z #n	Range: 0 to 50
Edge Transition #n	1	1	<ESC> w t #n	0 = White to Black 1 = Black to White 2 = Both
Edge Side #n (READ ONLY !!!)	1	1	<ESC> w u #n	0 = Top to Bottom 1 = Bottom to Top 2 = Left to Right 3 = Right to Left
Top Left Edge Row #n	0		<ESC> w v #n	Range: 0 to 2048
Top Left Edge Column #n	0		<ESC> w w #n	Range: 0 to 2048
Bottom Right Edge Row #n	0		<ESC> w x #n	Range: 0 to 2048
Bottom Right Edge Column #n	0		<ESC> w y #n	Range: 0 to 2048

4.23 DATA MATRIX SETTINGS (FOR DPM)

25 PIN CONNECTOR MODELS ETHERNET MODELS

PARAMETER	TYPE	SEL	STRING	DATA
COMMON SETTING				
Image Rescaling	1	1	<ESC> y !	0 = None 1 = 2 x 2 2 = 4 x 4
Code Orientation	1	1	<ESC> y h	0 = Aligned 1 = Free
DATA MATRIX SETTING (DEPTH: n = 1 to 10)				
Status	1	1	<ESC> y k #n	0 = Disabled 1 = Enabled
Setting Timeout (ms)	0		<ESC> y + #n	Range: 1 to 30000
Processing Mode	1	1	<ESC> y m #n	0 = Standard, 1 = Advanced Code Setting 2 = Low Height Codes
Image Mirroring	1	1	<ESC> y n #n	0 = Disabled 1 = Enabled

PARAMETER	TYPE	SEL	STRING	DATA
Image Filter # <i>n</i>	1	1	<ESC> y o # <i>n</i>	0 = None 1 = Erode 2 = Dilate 3 = Open 4 = Close 5 = Contrast Stretching 6 = Histogram Equalization 7 = Smoothing 8 = Sharpening 9 = Deblurring 10 = Black Enhancement 11 = White Enhancement
Image Filter Dimensions	1	1	<ESC> y p # <i>n</i>	0 = 3x3 1 = 5x5 2 = 7x7
Code Color	1	1	<ESC> y q # <i>n</i>	0 = Black 1 = White 2 = Both Colors
Code Contrast	1	1	<ESC> y r # <i>n</i>	0 = High 1 = Standard 2 = Low 3 = Very Low 4 = Automatic
Decoding Method	1	1	<ESC> y s # <i>n</i>	0 = Standard 1 = Direct Marking
Rectangular Formats	1	1	<ESC> y v # <i>n</i>	0 = Disabled 1 = Enabled
Decoding Performance	1	1	<ESC> y l # <i>n</i>	0 = Quick 1 = Robust
Code Size	1	1	<ESC> y t # <i>n</i>	0 = Defined 1 = Free
Number Of Modules	4	30	<ESC> y w # <i>n</i>	1 = 10x10 2 = 12x12 4 = 14x14 8 = 16x16 16 = 18x18 32 = 24x24 64 = 20x20 128 = 22x22 256 = 24x24 512 = 26x26 1024 = 12x26 2048 = 32x32 4096 = 8x32 8192 = 12x36 16384 = 16x36 32576 = 16x48 65536 = 36x36 131072 = 40x40 262144 = 44x44 524288 = 48x48 1048576 = 52x52 2097152 = 64x64 4194304 = 72x72 8388608 = 80x80 16777216 = 88x88 33554432 = 96x96 67108864 = 104x104

PARAMETER	TYPE	SEL	STRING	DATA
				134217728 = 120x120 268435456 = 132x132 536870912 = 144x144
Module Size (mils)	0		<ESC> y z #n	Range: 1 to 1000
Decoding Time Improvement	1	1	<ESC> y u #n	0 = Disabled 1 = Enabled
Legacy	1	1	<ESC> y y #n	0 = Disabled 1 = Enabled

 **NOTE** Special characters <FE_H> and <FD_H> must be added after #n in the programming string to indicate parameter **Depth > 9**. Refer to paragraph 3.2 for further details.

A DIRECT COMMANDS FROM HOST

The following commands **are NOT** Host Mode Programming commands. They are sent directly to the reader from the Host to perform their specific functions.

ID-NET™ (MULTIDATA) SLAVE COMMANDS

The following command allows sending an "encapsulated" command string to a (Multidata) Slave #N through the Master (Multidata) device in an ID-NET™ reading system layout.

This command can be used to send Reading Phase ON, Acquisition Trigger and Reading Phase OFF strings (for One Shot and Phase Mode operating modes) to a Multidata Slave device in an ID-NET™ reading system layout.

The Matrix 210™ '**Send String To Slave Device #N**' special command must have the following format:

<ESC> (<B0_H> ADDR STRING) <ESC>

Where:

- **ADDR:** Device Address
- **STRING:** String To Send (Length: 1 to 32)

ADDR is a character indicating address of the device in an ID-NET™ Master/Slave Multidata reading system layout:

ADDR = <30_H> + <Device Address> where:

- Device Address = 0:** Standalone device or Master Multidata ID-NET™ device
- Device Address = 1 to 31:** Slave Multidata ID-NET™ device
- Device Address = 32:** ID-NET™ broadcast address

This means:

- ADDR = <30_H>:** Standalone device or Master Multidata ID-NET™ device
- ADDR = <31_H> to <4F_H>:** Slave Multidata ID-NET™ device
- ADDR = <50_H>** ID-NET™ broadcast address

ON DEMAND TRANSFER ARRAY IMAGE COMMAND

All the images stored in the Transfer Array Image Buffer can be sent over the dedicated Transfer Image FTP Client if requested by the Host (On Demand). To do this the Host must send the following command string over the Ethernet Data Socket channel:

<ESC> [T I <node> (hex values 1B 5B 54 49 xx)

Where <node> (xx) = reader node address:

0 (hex **00**) = download images from Master

1 to 31 (hex **01 to 1F**) = download images from Slave xx

255 (hex **FF**) = download images from entire array

The Matrix reader does not reply to this command.

ROTATE LAST IMAGE COMMAND

	DESCRIPTION	HOST COMMAND	REPLY MESSAGE
1	Rotate Last Image	<ESC> <ACK>	<ESC> K <CR><LF> <ESC> W 1 <CR><LF>
	<p>After sending this command the reader activates the Code Rotation on the last image present in the Image Buffer. It uses the Code rotation info in order to obtain a Code orientation equal to 0 degrees. This command is meaningful only when a code is present in the last image of the Image Buffer.</p> <p>If the command is correct, the device confirms with the first reply message. If programming command is wrong (i.e. no image present in the Image Buffer) or due to a transmission error, Matrix replies with the second error message.</p>		

DECODE LAST IMAGE COMMAND

	DESCRIPTION	HOST COMMAND	REPLY MESSAGE
1	Decode Last Image	<ESC> <BEL>	<ESC> K <CR><LF> <ESC> W 1 <CR><LF>
	<p>After sending this command the reader Decodes any barcode present in the last image of the Image Buffer.</p> <p>If the command is correct, the device confirms with the first reply message. If programming command is wrong (i.e. no image present in the Image Buffer) or due to a transmission error, Matrix replies with the second error message.</p>		

B CBX GATEWAY FIELDBUS RESET

Setting the following parameters via Host Mode Programming (or via VisiSet™ interactive mode) determines the Fieldbus board reset, independently from the channel used for configuration (i.e. even the Fieldbus channel itself).

READING SYSTEM LAYOUT --> Device Network Setting
DEVICE NETWORK SETTING --> Topology Role
OPERATING MODE --> Operating Mode
OPERATING MODE --> Reading Phase ON
OPERATING MODE --> Acquisition Trigger (in Phase Mode)
OPERATING MODE --> Acquisition Trigger (in One Shot)
OPERATING MODE --> Reading Phase OFF
OUTPUT1 --> Line Function
OUTPUT2 --> Line Function
OUTPUT3 --> Line Function (if present)
DEVICE NETWORK SETTING --> Address TX (Multidata Master only)
DEVICE NETWORK SETTING --> Address Header String (Multidata Master only)
DEVICE NETWORK SETTING --> Address Separator String (Multidata Master only)

Note that this event does NOT involve the Matrix device reset, only the Fieldbus board.

The involved Fieldbus boards are:

- BM3x0 Profibus Module (or QLM600)
- BM400 DeviceNet Module
- BM5x0 Ethernet/IP Module (or QLM500)
- BM600 CANopen Module
- BM7x0 Profinet Module (or QLM700)
- BM1100 CC-Link Module
- BM12x0 Modbus TCP Module

C ASCII TABLE

CHARACTER CONVERSION TABLE								
CHAR	DEC	HEX	CHAR	DEC	HEX	CHAR	DEC	HEX
NUL	0	00	*	42	2A	U	85	55
SOH	1	01	+	43	2B	V	86	56
STX	2	02	,	44	2C	W	87	57
ETX	3	03	-	45	2D	X	88	58
EOT	4	04	.	46	2E	Y	89	59
ENQ	5	05	/	47	2F	Z	90	5A
ACK	6	06	0	48	30	[91	5B
BEL	7	07	1	49	31	\	92	5C
BS	8	08	2	50	32]	93	5D
HT	9	09	3	51	33	^	94	5E
LF	10	0A	4	52	34	~	95	5F
VT	11	0B	5	53	35	a	96	60
FF	12	0C	6	54	36	b	97	61
CR	13	0D	7	55	37	c	98	62
SO	14	0E	8	56	38	d	99	63
SI	15	0F	9	57	39	e	100	64
DLE	16	10	:	58	3A	f	101	65
DC1	17	11	;	59	3B	g	102	66
DC2	18	12	<	60	3C	h	103	67
DC3	19	13	=	61	3D	i	104	68
DC4	20	14	>	62	3E	j	105	69
NAK	21	15	?	63	3F	k	106	6A
SYN	22	16	@	64	40	l	107	6B
ETB	23	17	A	65	41	m	108	6C
CAN	24	18	B	66	42	n	109	6D
EM	25	19	C	67	43	o	110	6E
SUB	26	1A	D	68	44	p	111	6F
ESC	27	1B	E	69	45	q	112	70
FS	28	1C	F	70	46	r	113	71
GS	29	1D	G	71	47	s	114	72
RS	30	1E	H	72	48	t	115	73
US	31	1F	I	73	49	u	116	74
SPACE	32	20	J	74	4A	v	117	75
!	33	21	K	75	4B	w	118	76
"	34	22	L	76	4C	x	119	77
#	35	23	M	77	4D	y	120	78
\$	36	24	N	78	4E	z	121	79
%	37	25	O	79	4F	{	122	7A
&	38	26	P	80	50		123	7B
'	39	27	Q	81	51	}	124	7C
(40	28	R	82	52	~	125	7D
)	41	29	S	83	53	DEL	126	7E
			T	84	54		127	7F

