

GUIDA PER L'INSTALLAZIONE RAPIDA
QUICK INSTALLATION GUIDE

AREX



Headquarters

Via Lavino, 265
40050 Monte San Pietro
Bologna - Italy
Tel. +39 051 6765611
Fax +39 051 6759324
Purchasing Dept. Fax +39 051 6765499
info.automation.it@datalogic.com

Laser Marking operation offices

Donnas

Reg. Gurey, via Le Gorrey, 10
11020 Donnas (AO) - ITALY
Tel. +39 0125 8128201
Fax +39 0125 8128401

Sesto Calende

Via dell'Industria, 20
21018 Sesto Calende (VA) - ITALY
Tel. +39 0331 9180601
Fax +39 0331 9180801

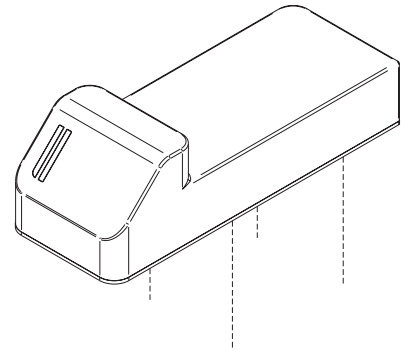

1. Fissare risonatore.
1. Fixing resonator.

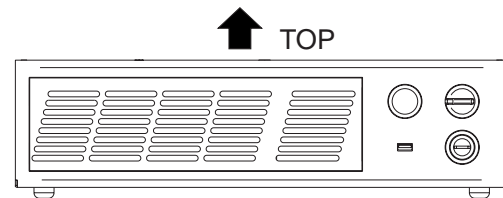

2. Fissare Rack di controllo.
2. Secure control rack.

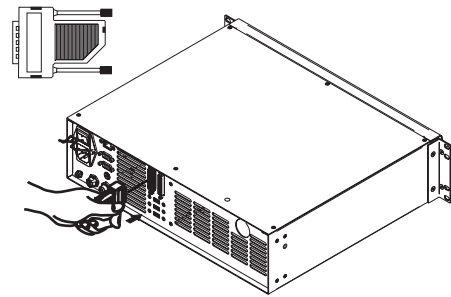

3. Collegare la Command Box.
3. Plug the Command Box.

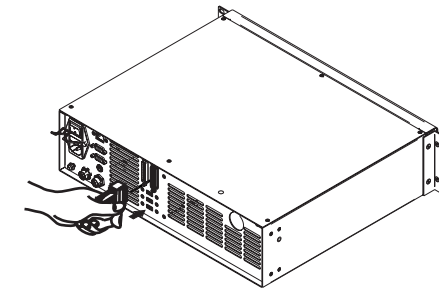

4. Collegare gli assi.
4. Plug the axes.

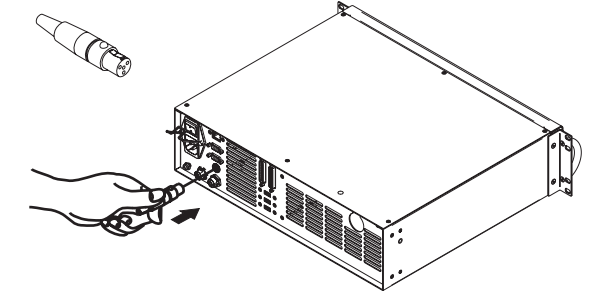

5. Collegare il connettore di Interlock.
5. Plug the Interlock connector.

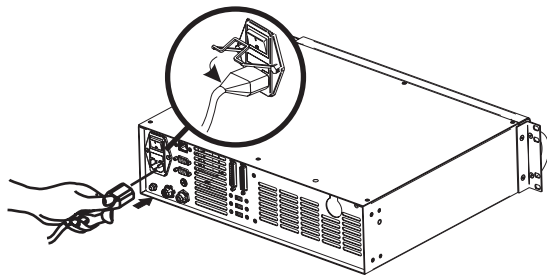

6. Collegare il cavo di alimentatore.
6. Plug power supply cable.

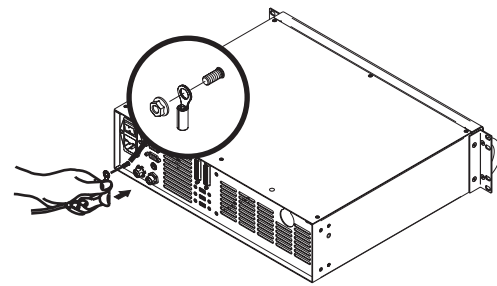

7. Collegare la messa a terra.
7. Plug the GND.

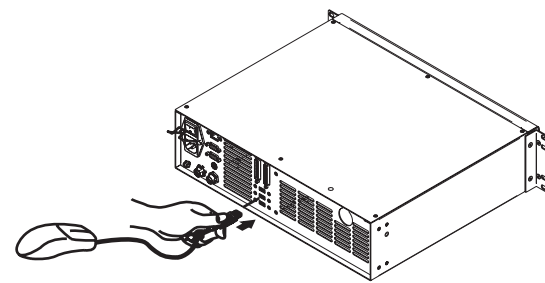

8. Collegare il mouse.
8. Plug the mouse.

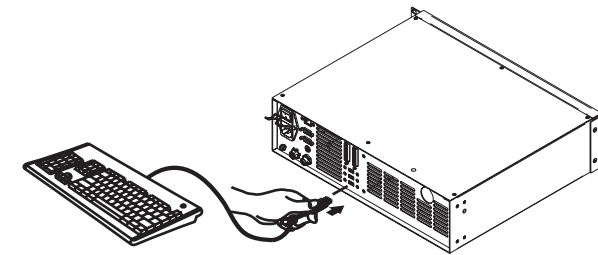

9. Collegare la tastiera.
9. Plug the keyboard.

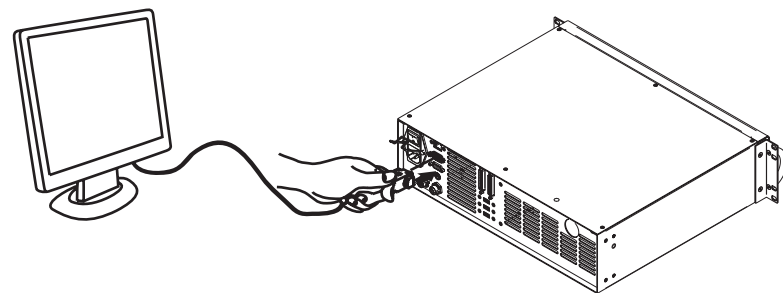

10. Collegare il monitor.
10. Plug the monitor.

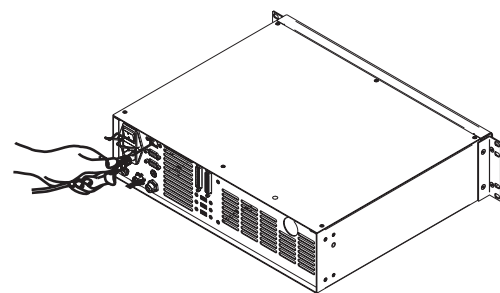

11. Collegare cavo ethernet.
11. Plug ethernet cable.

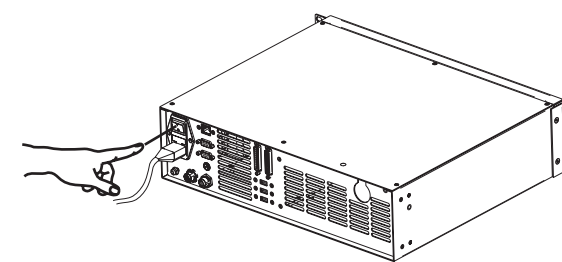

12. Accendere il dispositivo.
12. Power ON the device.

ESEMPIO DI CONNESSIONE.
EXAMPLE OF CONNECTION.

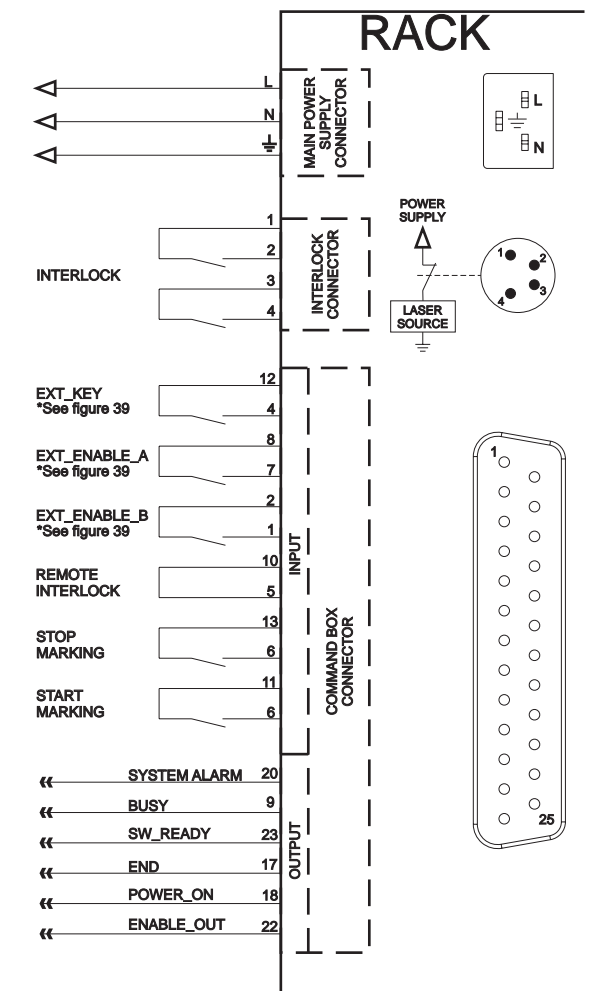

NOTA:
Per una corretta installazione del dispositivo **Arex**, consultare il Manuale d'Uso
NOTE:
For a right installation of **Arex** devices, please consult User's Manual



ATTENZIONE:
Il dispositivo **Arex** è un laser di classe 4. Per il corretto utilizzo in sicurezza deve essere portato a classe 1.
ATTENTION:
The **Arex** device is a class 4 laser. For proper use in full safety, it must be modified to class 1.