



---

## **SG BODY BASE**



**Instruction Manual**

---



**ORIGINAL INSTRUCTIONS (ref. 2006/42/EC)**

This product is covered by one or more of the following patents.  
Italian Patent IT 1,363,719

Additional patents pending

Datalogic Automation S.r.l.  
Via Lavino, 265  
40050 - Monte S. Pietro  
Bologna - Italy

SG BODY BASE Instruction Manual

Ed.: 08/2012

© 2012 Datalogic Automation S.r.l. □ ALL RIGHTS RESERVED. □ Protected to the fullest extent under U.S. and international laws. Copying, or altering of this document is prohibited without express written consent from Datalogic Automation S.r.l.

Datalogic and the Datalogic logo are registered trademarks of Datalogic S.p.A. in many countries, including the U.S.A. and the E.U.

All brand and product names mentioned herein are for identification purposes only and may be trademarks or registered trademarks of their respective owners.

Datalogic shall not be liable for technical or editorial errors or omissions contained herein, nor for incidental or consequential damages resulting from the use of this material.

01/08/12

**Datalogic Automation S.r.l.**

Via Lavino 265  
40050 Monte San Pietro  
Bologna - Italy  
[www.automation.datalogic.com](http://www.automation.datalogic.com)

*declares that the*

**SG2 ; SAFETY LIGHT CURTAINS - ELECTRO-SENSITIVE PROTECTIVE EQUIPMENT  
(TYPE 2 ESPE)**

*and all its models*

*are in conformity with the requirements of the European Council Directives listed below:*

**2006 / 42 / EC Machinery Directive  
2004 / 108 / EC EMC Directive  
2006 / 95 / EC Low Voltage Directive**

*This Declaration is based upon compliance of the products to the following standards:*

<b>EN 61496-1: 2004</b>	<b>SAFETY OF MACHINERY - ELECTRO-SENSITIVE PROTECTIVE EQUIPMENT. PART 1: GENERAL REQUIREMENTS AND TESTS</b>
<b>IEC 61496-2: 2006</b>	<b>SAFETY OF MACHINERY - ELECTRO-SENSITIVE PROTECTIVE EQUIPMENT. PART 2: PARTICULAR REQUIREMENTS FOR EQUIPMENT USING ACTIVE OPTO-ELECTRONIC PROTECTIVE DEVICES (AOPDs)</b>
<b>IEC 61508-1/3/4: 1998 IEC 61508-2:2000</b>	<b>FUNCTIONAL SAFETY OF ELECTRICAL/ELECTRONIC/PROGRAMMABLE ELECTRONIC SAFETY-RELATED SYSTEMS.</b>
<b>EN 954-1: 1996</b>	<b>SAFETY OF MACHINERY -- SAFETY-RELATED PARTS OF CONTROL SYSTEMS</b>
<b>EN ISO 13849-1: 2008</b>	<b>SAFETY OF MACHINERY -- SAFETY-RELATED PARTS OF CONTROL SYSTEMS -- PART 1: GENERAL PRINCIPLES FOR DESIGN</b>
<b>EN 62061: 2005</b>	<b>SAFETY OF MACHINERY -- FUNCTIONAL SAFETY OF SAFETY-RELATED ELECTRICAL, ELECTRONIC AND PROGRAMMABLE ELECTRONIC CONTROL SYSTEMS</b>
<b>EN 50178:1997</b>	<b>ELECTRONIC EQUIPMENT FOR USE IN POWER INSTALLATIONS</b>
<b>EN 61000-6-2: 2005</b>	<b>ELECTROMAGNETIC COMPATIBILITY (EMC) PART 6-2: GENERIC STANDARDS - IMMUNITY FOR INDUSTRIAL ENVIRONMENTS</b>
<b>EN 55022 (Class A ITE): 2010</b>	<b>LIMITS AND METHODS OF MEASUREMENTS OF RADIO DISTURBANCE OF INFORMATION TECHNOLOGY EQUIPMENT</b>

*Conformity has been certified by the following Notified/Competent Body (identification n°0123): TÜV SÜD Rail GmbH, Ridlerstrasse, 65 – D80339 München*

*Datalogic Automation have a quality system certified by the CSQ, Nr. 9115.IES2, as per ISO 9001 and have therefore observed the regulations foreseen during development and production*

Monte San Pietro, January 20th 2012

Paolo Morselli  
Quality Manager

*Morselli Paolo*





**Datalogic Automation S.r.l.**

Via Lavino 265  
40050 Monte San Pietro  
Bologna - Italy  
[www.automation.datalogic.com](http://www.automation.datalogic.com)

*declares that the*

**SG4 ; SAFETY LIGHT CURTAINS - ELECTRO-SENSITIVE PROTECTIVE EQUIPMENT  
(TYPE 4 ESPE)**

*and all its models*

*are in conformity with the requirements of the European Council Directives listed below:*

**2006 / 42 / EC Machinery Directive  
2004 / 108 / EC EMC Directive  
2006 / 95 / EC Low Voltage Directive**

*This Declaration is based upon compliance of the products to the following standards:*

<b>EN 61496-1: 2004</b>	<b>SAFETY OF MACHINERY - ELECTRO-SENSITIVE PROTECTIVE EQUIPMENT. PART 1: GENERAL REQUIREMENTS AND TESTS</b>
<b>IEC 61496-2: 2006</b>	<b>SAFETY OF MACHINERY - ELECTRO-SENSITIVE PROTECTIVE EQUIPMENT. PART 2: PARTICULAR REQUIREMENTS FOR EQUIPMENT USING ACTIVE OPTO-ELECTRONIC PROTECTIVE DEVICES (AOPDs)</b>
<b>IEC 61508-1/3/4: 1998 IEC 61508-2:2000</b>	<b>FUNCTIONAL SAFETY OF ELECTRICAL/ELECTRONIC/PROGRAMMABLE ELECTRONIC SAFETY-RELATED SYSTEMS.</b>
<b>EN 954-1: 1996 EN ISO 13849-1: 2008</b>	<b>SAFETY OF MACHINERY -- SAFETY-RELATED PARTS OF CONTROL SYSTEMS SAFETY OF MACHINERY -- SAFETY-RELATED PARTS OF CONTROL SYSTEMS -- PART 1: GENERAL PRINCIPLES FOR DESIGN</b>
<b>EN 62061: 2005</b>	<b>SAFETY OF MACHINERY -- FUNCTIONAL SAFETY OF SAFETY-RELATED ELECTRICAL, ELECTRONIC AND PROGRAMMABLE ELECTRONIC CONTROL SYSTEMS</b>
<b>EN 50178:1997 EN 61000-6-2: 2005</b>	<b>ELECTRONIC EQUIPMENT FOR USE IN POWER INSTALLATIONS ELECTROMAGNETIC COMPATIBILITY (EMC) PART 6-2: GENERIC STANDARDS - IMMUNITY FOR INDUSTRIAL ENVIRONMENTS</b>
<b>EN 55022 (Class A ITE): 2010</b>	<b>LIMITS AND METHODS OF MEASUREMENTS OF RADIO DISTURBANCE OF INFORMATION TECHNOLOGY EQUIPMENT</b>

*Conformity has been certified by the following Notified/Competent Body (identification n°0123): TÜV SÜD Rail GmbH, Ridlerstrasse, 65 – D80339 München*

*Datalogic Automation have a quality system certified by the CSQ, Nr. 9115.IES2, as per ISO 9001 and have therefore observed the regulations foreseen during development and production*

Monte San Pietro, January 20th 2012

Paolo Morselli  
Quality Manager

*Morselli Paolo*



# INDEX

---

<b>1. GENERAL INFORMATIONS ABOUT THIS DOCUMENT .....</b>	<b>1</b>
1.1. Purpose of this document.....	1
1.2. Intended readers .....	1
1.3. Informations for the use.....	1
<b>2. GENERAL INFORMATIONS ABOUT THE PRODUCT.....</b>	<b>1</b>
2.1. General description of the safety light curtains.....	1
2.2. Appearance and interface .....	2
2.2.1. <i>Package contents</i> .....	2
2.3. Main functions and new features.....	2
2.4. How to choose the device .....	2
2.4.1. <i>Resolution</i> .....	2
2.4.2. <i>Controlled height</i> .....	4
2.4.3. <i>Minimum installation distance</i> .....	6
2.5. Typical applications .....	8
2.6. Safety information .....	8
<b>3. INSTALLATION MODE.....</b>	<b>9</b>
3.1. Precautions to be observed for the choice and installation of the device .....	9
3.2. General information on device positioning .....	9
3.2.1. <i>Minimum installation distance</i> .....	11
3.2.2. <i>Minimum distance from reflecting surfaces</i> .....	11
3.2.3. <i>Distance between homologous devices</i> .....	13
3.2.4. <i>Emitter and receiver orientation</i> .....	15
3.2.5. <i>Use of deviating mirrors</i> .....	15
3.2.6. <i>Controls after first installation</i> .....	16
<b>4. MECHANICAL MOUNTING .....</b>	<b>17</b>
4.1. Side fixing brackets .....	17
4.2. Rotating brackets .....	17
4.3. Bottom fixing brackets .....	18
4.4. Vibration dampers .....	18
<b>5. ELECTRICAL CONNECTIONS AND CONFIGURATION .....</b>	<b>19</b>
5.1. Important notes for installation .....	19
5.2. Minimal connection.....	19
5.3. Complete connection list .....	19
5.4. Restart mode and Reset/Restart button connection.....	20
5.5. Test button connection .....	20
5.6. External relays connection .....	20
5.7. EDM ENABLE input connection .....	21
5.8. EDM control connection .....	21
5.9. Earth connection .....	22
<b>6. FUNCTIONING MODE .....</b>	<b>22</b>
6.1. Standard configuration .....	22
6.2. Reset function .....	23
6.3. Restart mode selection function .....	23
6.4. EDM function.....	24
6.5. Alignment function.....	25
6.6. Test .....	26
<b>7. ALIGNMENT PROCEDURE.....</b>	<b>27</b>
7.1. Light curtain alignment procedure .....	28
<b>8. DIAGNOSTICS .....</b>	<b>29</b>
8.1. User interface .....	29
8.2. Diagnostic messages .....	30
8.2.1. <i>RX side</i> .....	30
8.2.2. <i>TX side</i> .....	31
<b>9. PERIODICAL MAINTENANCE AND WARRANTY .....</b>	<b>31</b>
9.1. General information and useful data .....	32
9.2. Warranty.....	33
<b>10.DEVICE MAINTENANCE .....</b>	<b>33</b>
10.1. Product disposal.....	33
<b>11.TECHNICAL DATA .....</b>	<b>34</b>
<b>12.DIMENSIONS .....</b>	<b>35</b>

<b>13.ORDER DATA .....</b>	<b>36</b>
<b>14.ACCESSORIES .....</b>	<b>37</b>
14.1. Side fixing bracket .....	37
14.1.1. <i>Side fixing bracket mounting</i> .....	38
14.2. Rotative fixing bracket .....	39
14.2.1. <i>Rotative fixing bracket mounting</i> .....	39
14.3. Bottom fixing bracket .....	40
14.3.1. <i>Bottom fixing bracket mounting</i> .....	40
14.4. Deviating mirrors .....	41
14.5. Column and floor stands.....	42
14.6. Protective stands .....	43
14.7. Test Piece .....	43
14.8. Laser pointer .....	44
14.9. Connection cables .....	44
14.10. Safety relay SE-SR2.....	45
<b>15.GLOSSARY .....</b>	<b>46</b>



## 1. GENERAL INFORMATIONS ABOUT THIS DOCUMENT

Read this section carefully before implementing the instructions given in this manual and starting up the SG BODY safety system.

### 1.1. Purpose of this document

These instructions for use are addressed to the manufacturer technicians or staff operating the machine and give all necessary instructions for correct and safe assembly, setup, electric connection and commissioning of the SG BODY series light curtains.

Scope of this document excludes information about use of the machine the safety system is installed to.

### 1.2. Intended readers

The instructions for use given herein are addressed to designers, manufacturers and persons in charge of the safety of systems to be equipped with the SG BODY series light curtains. They are also addressed to the staff in charge of installing the SG BODY light curtain to a machine, commissioning it or servicing it.

### 1.3. Informations for the use

These instructions for use contain the following details about the SG BODY series light curtains:

- installation	- diagnostics and troubleshooting
- electrical connection	- user interface warnings
- commissioning and setup	- conformity and type approval
- application	- care and maintenance

Designing and using safety devices to integrate to the SG BODY safety system requires specific know-how which is not included in this document. In particular, the applicable industry standards shall be met.

General information about accident-prevention protection by means of optoelectronic safety devices can be found in the "Safety guide" available on the product CD-Rom provided with the product.

For all the acronyms used in this document please refer to section 15.

## 2. GENERAL INFORMATIONS ABOUT THE PRODUCT

### 2.1. General description of the safety light curtains

The safety light curtains of the SG BODY series are optoelectronic multibeams devices that are used to protect working areas that, in presence of machines, robots, and automatic systems in general, can become dangerous for operators that can get in touch, even accidentally, with moving parts.

The light curtains of the SG BODY series are safety systems used as accident-prevention protection devices and are manufactured in accordance with the international Standards in force for safety, in particular:

**CEI EN 61496-1: 2004** Safety of machinery: electro-sensitive protective equipment.  
Part 1: General prescriptions and tests.

**CEI IEC 61496-2: 2006** Safety of machinery: electro-sensitive protective equipment.  
Particular requirements for equipment using active optoelectronic protective devices.

The device, consisting of one emitter and one receiver housed inside strong aluminium profiles, generates infrared beams that detect any opaque object positioned within the light curtain detection field.

The emitter and the receiver are equipped with the command and control functions. The connections are made through a M12 connector located in the lower side of the profile.

The synchronisation between the emitter and the receiver takes place optically, *i.e.* no electrical connection between the two units is required.

The microprocessor guarantees the check and the management of the beams that are sent and received through the units: The microprocessor LEDs and display inform the operator about the general conditions of the safety light curtain (see section 8 – "DIAGNOSTICS").

The device consists in 2 units that, according to the model, are composed by one or several emitting and receiving modules. The receiver checks the control operations and safety actions.

During installation, an user interface facilitates the alignment of both units (see section 7 – “ALIGNMENT PROCEDURE”).

As soon as an object or the operator’s body accidentally interrupts one or some of the infrared beams sent by the emitter, the receiver immediately opens the OSSD outputs and blocks the MPCE machine (if correctly connected to the OSSD).

Some parts or sections of this manual containing important information for the user or installing operator are preceded by a note:



Notes and detailed descriptions about particular characteristics of the safety devices in order to better explain their functioning.

Special instructions regarding the installation process.



The information provided in the paragraphs following this symbol is very important for safety and may prevent accidents.

Always read this information accurately and carefully follow the advice to the letter.

This manual contains all the information necessary for the selection and operation of the safety devices.

However, specialised knowledge not included in this technical description is required for the planning and implementation of a safety light curtain on a power-driven machine. As the required knowledge may not be completely included in this manual, we suggest the customer to contact DATALOGIC AUTOMATION Technical Service for any necessary information relative to the functioning of the SG BODY light curtains and the safety rules that regulate the correct installation (see section 9 – “PERIODICAL MAINTENANCE AND WARRANTY”).

## 2.2. Appearance and interface

### 2.2.1. Package contents

Package contains the following objects:

- Receiver (RX)
- Emitter (TX)
- SG BODY quick installation guide
- SG BODY CD containing instruction manual and other documents
- Checklist and periodical maintenance schedule

### 2.3. Main functions and new features

With respect to SE2-P, SE4-P, SE4-Q and SE4-S series, the SG BODY safety light curtain series present new important features:

- Increased operating distance
- No dead zone (except for SG4-40 models)
- Shorter response time (see section 11 – “TECHNICAL DATA”)

### 2.4. How to choose the device

There are at least three different main characteristics that should be considered when choosing a safety light curtain, after having evaluated the risk assessment:





#### 2.4.1. Resolution

The resolution of the device is the minimum dimension that an opaque object must have in order to obscure at least one of the beams that constitute the sensitive area.

The resolution strictly depends on the part of the body to be protected.

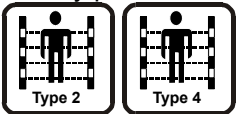
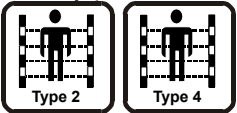
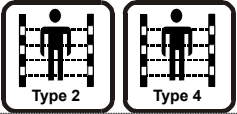
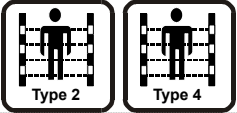
The following table shows the values of the optic interaxis (**I**), the resolution (**R**) and the optic diameter (**d**), of the safety light curtains.



Model	Optic interaxis (I) [mm]	N. optics	Resolution (R) [mm]	Lens diameter (d) [mm]	ESPE Type
SGx-B2-050-OO-E	500	2	519,75	19,75	Body protection 
SGx-B3-080-OO-E	400	3	419,75	19,75	Body protection 
SGx-B4-090-OO-E	300	4	319,75	19,75	Body protection 
SGx-B4-120-OO-E	400	4	419,75	19,75	Protezione corpo 
SG4-40-060-OO-E	20	33	40	19,75	Hand protection 
SG4-40-090-OO-E	20	48	40	19,75	Hand protection 
SG4-40-120-OO-E	20	63	40	19,75	Hand protection 

x = ESPE Type: 2,4

As shown in Fig.1 and Fig.2, the resolution depends only on the geometrical characteristics of the lenses, diameter and distance between centres, and is independent from any environmental and operating conditions of the safety light curtain.

Figure 2 refers to SG4-040-xxx-OO-E models; Figure 1 refers to all the other models.

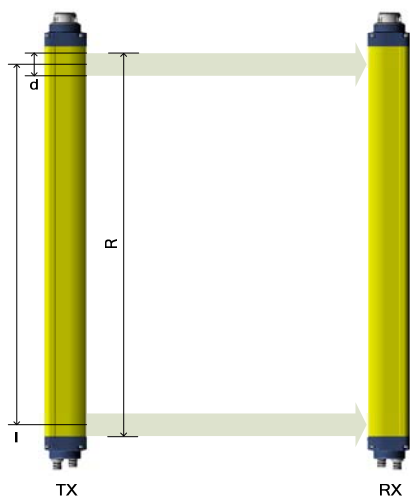

Figure 1

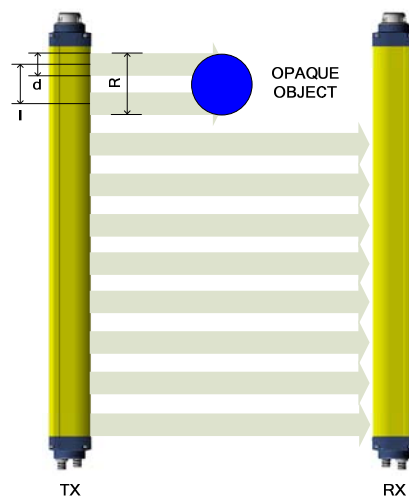

Figure 2

The resolution value is obtained applying the following formula:  $R = l + d$

where:

$l =$  Distance between two adjacent optics

$d =$  Lens diameter



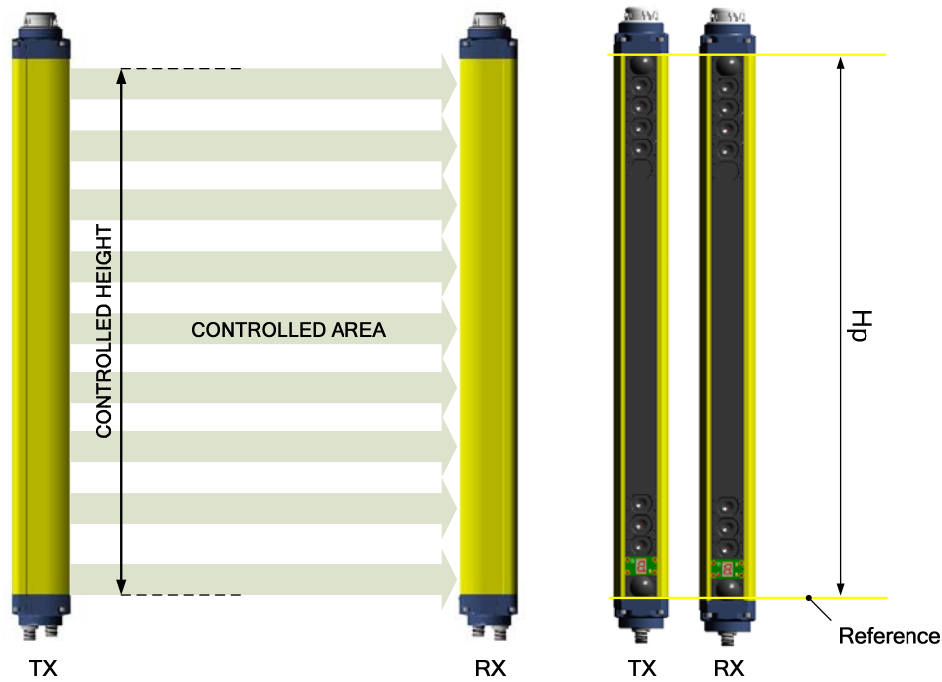

**Note: Safety light curtains for body protection with sensitive area heights and optic interaxis different from the standard versions can be manufactured upon specific request.**

**2.4.2. Controlled height**

The controlled height is the height protected by the safety light curtain ( $H_p$ ). Except for SG4-40-xxx-OO-E models, SG BODY models have no dead zone inside the protected area.

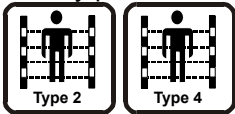
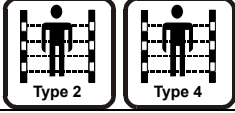
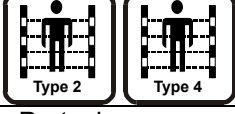
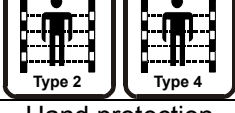

**Figure 2**

Model	H <sub>p</sub> [mm]	ESPE Type
SGx-B2-050-OO-E	500	Body protection 
SGx-B3-080-OO-E	800	Body protection 
SGx-B4-090-OO-E	900	Body protection 
SGx-B4-120-OO-E	1200	Protezione corpo 
SG4-40-060-OO-E	660	Hand protection 
SG4-40-090-OO-E	960	Hand protection 
SG4-40-120-OO-E	1260	Hand protection 

x = ESPE Type: 2,4

As shown in Figure 3, SG4-040-xxx-OO-E models has a dead zone between the M12 connector and the first lens after the user interface. The controlled height for this models is delimited by a yellow line pad-printed on the front glass (Figure 4); the dimensions of the controlled heights are listed in the previous table.

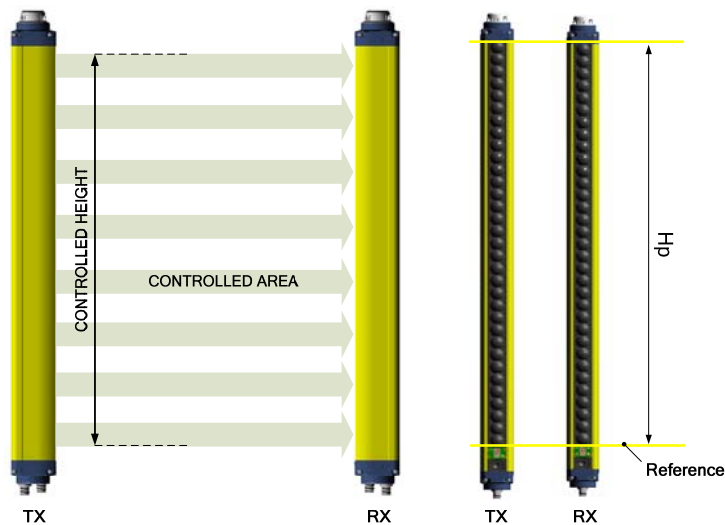

Figure 3

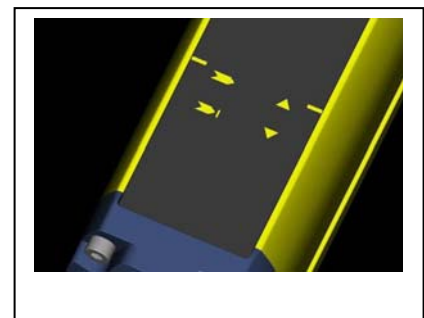

Figure 4

### 2.4.3. Minimum installation distance

As shown in Figure 4, the safety device must be positioned at a specific safety distance. This distance must ensure that the dangerous area cannot be reached before the dangerous motion of the machine has been stopped by the ESPE.

The safety distance depends on 4 factors, according to the **EN-999 "Safety of machinery - The positioning of protective equipment in respect of approach speeds of parts of the human body"** Standard:

- Response time of the ESPE (the time between the effective beam interruption and the opening of the OSSD contacts).
- Machine stopping time (the time between the effective opening of the contacts of the ESPE and the real stop of the dangerous motion of the machine).
- ESPE resolution.
- Approaching speed of the object to be detected.

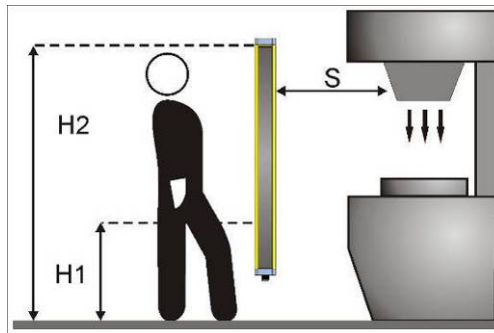



Figure 4

The following formula is used for the calculation of the safety distance:

$$S = K (t_1 + t_2) + C$$

where:

- S = Minimum safety distance in mm.
- K = Speed of the object, limb or body approaching the dangerous area in mm/sec.
- t<sub>1</sub> = Response time of the ESPE in seconds (see section 11 – "TECHNICAL DATA")
- t<sub>2</sub> = Machine stopping time in seconds.
- d = Resolution of the system.
- C = Additional distance based on the possibility to insert the body or one of body parts inside the dangerous area before the protective device trips.
- C = 8 (d - 14) for devices with resolution ≤ 40mm
- C = 850 mm for devices with resolution > 40mm

 NOTE: K value is:  
 2000 mm/s if the calculated value of S is ≤ 500 mm  
 1600 mm/s if the calculated value of S is > 500 mm

When devices with > 40 mm resolution are used, the height of the top beam has to be ≥ 900 mm (H2) from machine supporting base while the height of the bottom beam has to be ≤ 300 mm (H1).  
 If the safety light curtain must be mounted in a horizontal position (Figure 5), the distance between the dangerous area and the most distant optical beam must be equal to the value calculated using the following formula:

$$S = 1600 \text{ mm/s } (t_1 + t_2) + 1200 - 0.4 H$$

where:

- S = Minimum safety distance in mm.
- t<sub>1</sub> = Response time of the ESPE in seconds (see section 11 – “TECHNICAL DATA”)
- t<sub>2</sub> = Machine stopping time in seconds.
- H = Beam height from ground. This height must always be less than 1000 mm.

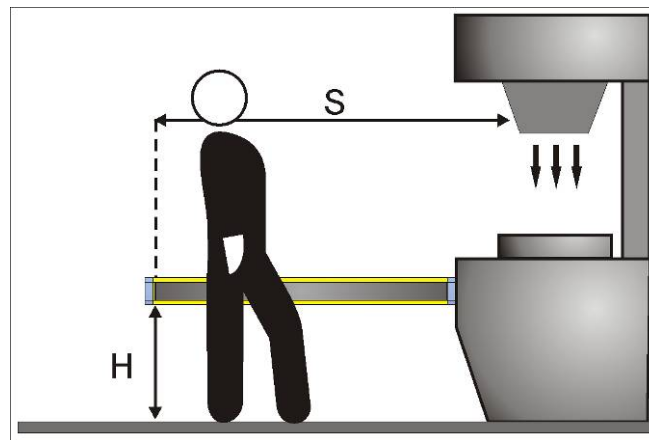

Figure 5

**Practical examples**

Let's suppose to have a light curtain with height = 500 mm  
 To calculate the distance of the device from the ESPE, in a vertical position, the following formula is used:

$$S = K * T + C$$

where:

- T = t<sub>1</sub> + t<sub>2</sub>
- t<sub>1</sub> = ESPE response time + SE-SR2 relay release time (max 80 ms)
- t<sub>2</sub> = Machine total stopping time (e.g. 300 ms).
- C = 8 (d -14) for devices with resolution ≤ 40mm
- C = 850 mm for devices with resolution > 40mm
- d = resolution

In all cases, if K = 2000mm/sec then S > 500 mm. Distance will have then to be recalculated using K = 1600 mm/sec.

	SGx-B2	SGx-B4	SG4-40-060
T [sec]	0.391	0.393	0.4
C [mm]	850	850	208
S [mm]	1475.6	1478.8	848

x = ESPE Type: 2,4



**WARNING:** The reference standard is *EN 999 "Machine safety - the positioning of the protective device based on the approaching speed of the human body"*. The following information is to be considered as indicative and concise. For correct safety distance please refer to complete standard EN-999.

## 2.5. Typical applications

The **SAFEasy**<sup>TM</sup> safety light curtains are used in all automation fields where the control and protection of access to dangerous zones is necessary.

In particular they are used to stop the moving mechanical parts of:

- Automatic machines
  - Packaging machines, handling machines, storing machines
  - Wood working machines, glass working machines, ceramics working machines, etc.
  - Automatic and semi-automatic assembly lines
  - Automatic warehouses
- Presses, punching machines, benders and cutters

In food industry applications, DATALOGIC AUTOMATION Technical Service has to verify the compatibility of the material of the safety light curtain housing with any chemical agents used in the production process.

## 2.6. Safety information



For a correct and safe use of the safety light curtains of the SG BODY series, the following points must be observed:

- The stopping system of the machine must be electrically controlled.
- This control system must be able to stop the dangerous movement of the machine within the total machine stopping time T as per paragraph 2.4.3, and during all working cycle phases.
- Mounting and connection of the safety light curtain must be carried out by qualified personnel only, according to the indications included in the special sections (refer to sections 3, 4, 5, 7) and to the applicable standards.
- The safety light curtain must be securely placed in a particular position so that access to the dangerous zone is not possible without the interruption of the beams (refer section 3 – "INSTALLATION MODE").
- The personnel operating in the dangerous area must be well trained and must have adequate knowledge of all the operating procedures of the safety light curtain.
- The TEST button must be located outside the protected area because the operator must check the protected area during all the Test operation.
- The RESET/RESTART button must be located outside the protected area because the operator must check the protected area during all the Reset/Restart operations.
- The function of the external device monitoring (EDM) is active only if the specific wire is correctly connected to the device. Please carefully read the instructions for the correct functioning before powering the light curtain.
- Please carefully read the instructions for the correct functioning before powering the light curtain.

### 3. INSTALLATION MODE

#### 3.1. Precautions to be observed for the choice and installation of the device



Make sure that the protection level assured by the SG BODY series device (Type 2 or Type 4 respectively) is compatible with the real danger level of the machine to be controlled, according to EN 954-1 and EN13849-1.

- The outputs (OSSD) of the ESPE must be used as machine stopping devices and not as command devices (the machine must have its own START command).
- The dimension of the smallest object to be detected must be larger than the resolution level of the device.
- The ESPE must be installed in a room complying with the technical characteristics indicated in section 11 - TECHNICAL DATA. Datalogic Automation does not recommend the use of the product in ambients where direct or indirect exposure to solar light is present.
- Do not install device near strong and/or flashing light sources or close to similar devices.
- Strong electromagnetic disturbance might negatively affect device operation. Should this be the case contact DATALOGIC Technical Service.
- The operating distance of the device can be reduced in presence of smog, fog or airborne dust.
- A sudden change in environment temperature, with very low minimum peaks, can generate a small condensation layer on the lenses and so jeopardise functioning.

#### 3.2. General information on device positioning

Pay special care when positioning the safety light curtain so to offer effective protection. The device should be installed in such a way that the dangerous area can only be entered after detecting the sensitive area.



Figure 6 shows some examples of possible access to the machine from the top and the bottom sides. These situations may be very dangerous and so the installation of the safety light curtain at sufficient height in order to completely cover the access to the dangerous area becomes necessary (see Figure 57).

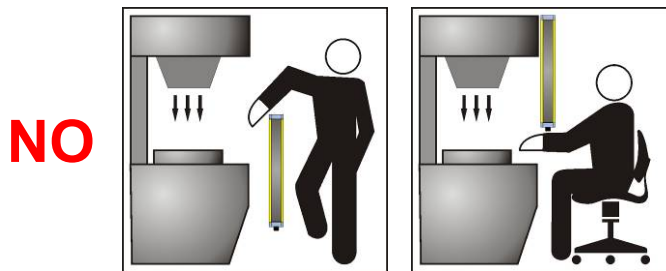

Figure 6



YES



Figure 7



Under standard operating conditions, machine starting must not be possible while operators are inside the dangerous area.

When the installation of the safety light curtain very near to the dangerous area is not possible, a second light curtain must be mounted in a horizontal position in order to prevent any lateral access, as shown in Figure 9.



If the operator is able to enter the dangerous area, an additional mechanical protection must be mounted to prevent the access.

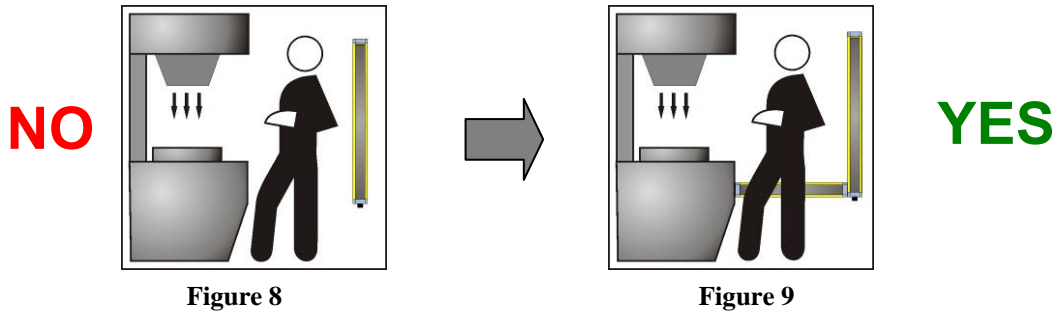

3.2.1. *Minimum installation distance*

Refer to paragraph 2.4.3 - Minimum installation distance.

3.2.2. *Minimum distance from reflecting surfaces*

Reflecting surfaces placed near the light beams of the safety device (over, under or laterally) can cause passive reflections. These reflections can affect the recognition of an object inside the controlled area.

However, if the RX receiver detects a secondary beam (reflected by the side-reflecting surface) the object might not be detected, even if the object interrupts the main beam.

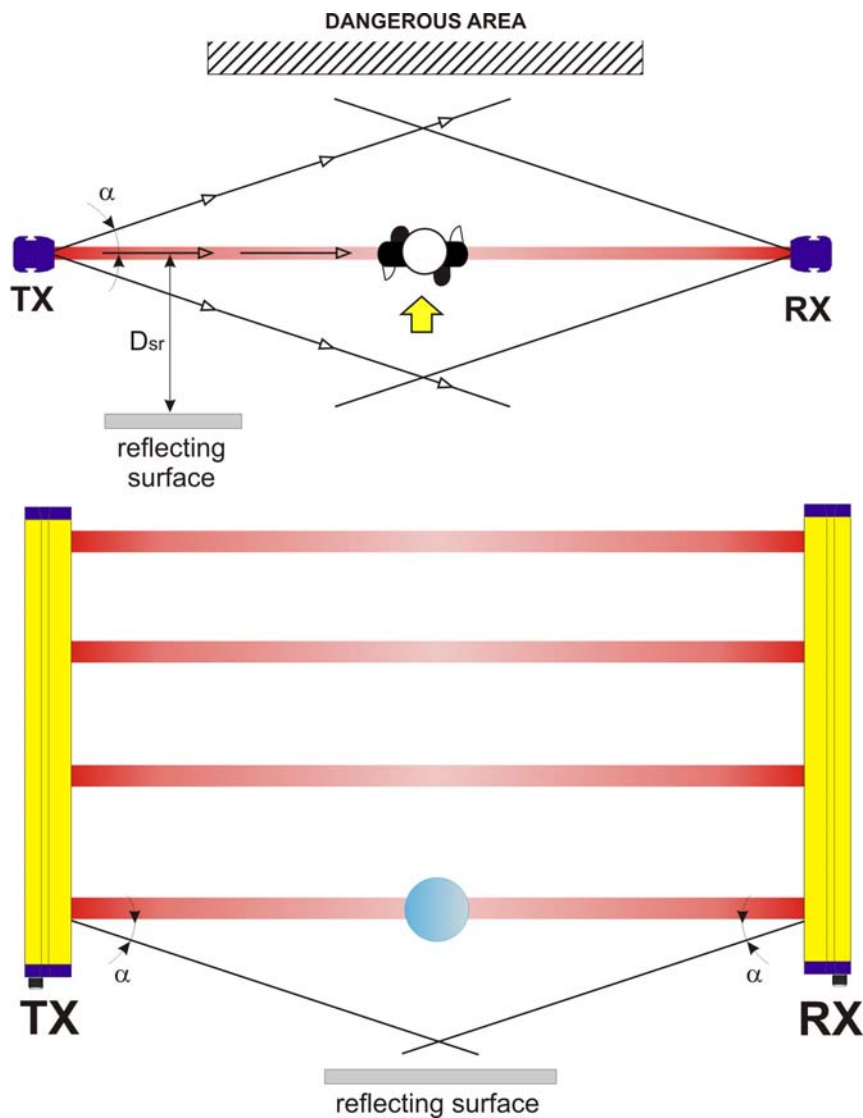

Figure 10

It is thus important to position the safety light curtain according to the minimum distance from reflecting surfaces.

The minimum distance depends on:

- operating distance between emitter (TX) and receiver (RX);
- real aperture angle of ESPE (EAA); especially:

for ESPE type 4  $EAA_{MAX} = 5^\circ$  ( $\alpha = \pm 2.5^\circ$ )

for ESPE type 2  $EAA_{MAX} = 10^\circ$  ( $\alpha = 5^\circ$ )

**Type 4 ESPE**

Diagram of Figure 11 shows the minimum distance from the reflecting surface ( $D_{sr}$ ), based on the operating distance for a Type 4 ESPE:

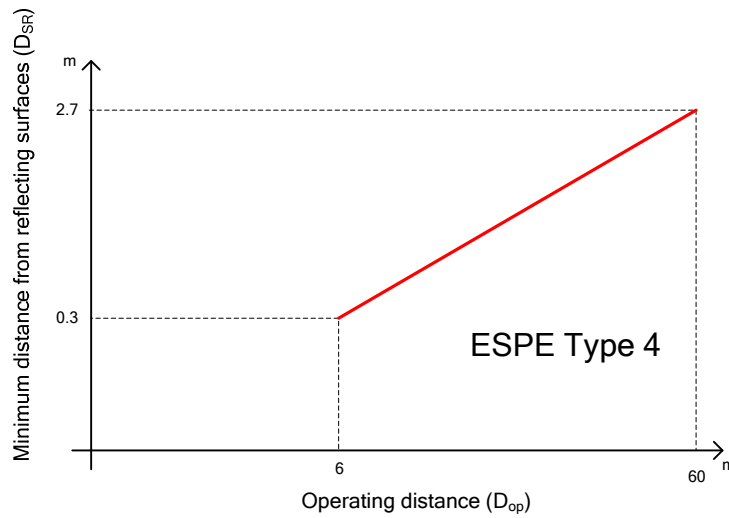

**Figure 11**

The formula to get  $D_{sr}$  for a Type 4 ESPE is the following:

$$D_{sr} (m) = 0.5 \times \text{operating distance (m)} \times \text{tg } 2\alpha \quad \text{for operating distance} \geq \text{di } 6 \text{ m}$$

**Type 2 ESPE**

Diagram of Figure 12 shows the minimum distance from the reflecting surface ( $D_{sr}$ ), based on the operating distance for a Type 2 ESPE:

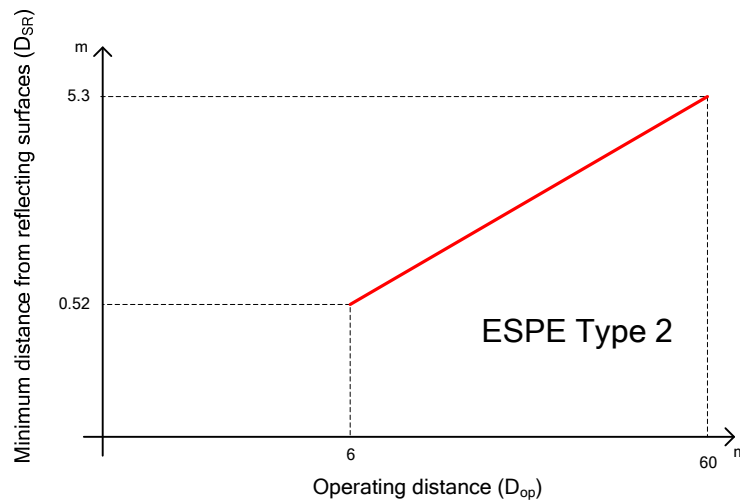

**Figure 12**

The formula to get  $D_{sr}$  for a Type 2 ESPE is the following:

$$D_{sr} (m) = 0,5 \text{ operating distance (m)} \times \text{tg } 2\alpha \quad \text{for operating distance} \geq \text{di } 6 \text{ m}$$

3.2.3. Distance between homologous devices

If different safety devices have to be installed in adjacent areas, the emitter of one device must not interfere dangerously with the receiver of the other device.

The TX<sub>B</sub> interfering device must be positioned outside a minimum D<sub>do</sub> distance from the TX<sub>A</sub> – RX<sub>A</sub> emitter-receiver couple axis.

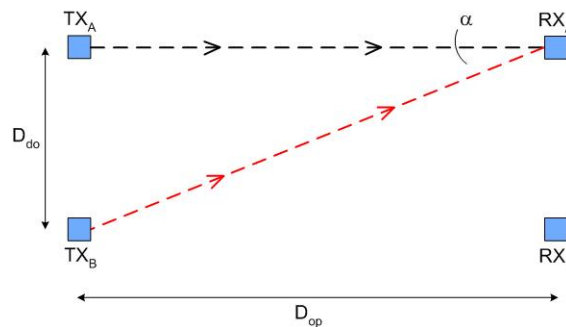

Figure 13

This minimum D<sub>do</sub> distance depends on:

- the operating distance between emitter (TX<sub>A</sub>) and receiver (RX<sub>A</sub>)
- the effective aperture angle of the ESPE (EAA); especially:

- for ESPE type 4 EAA<sub>MAX</sub> = 5° (α = ± 2.5°)
- for ESPE type 2 EAA<sub>MAX</sub> = 10° (α = 5°)

**WARNING:** the interfering device (TX<sub>B</sub>) must be positioned at the same D<sub>do</sub> distance, calculated as shown above, even if closer to TX<sub>A</sub> respect to RX<sub>A</sub>.

Type 4 ESPE

The following graphic shows the distance from the interfering devices (D<sub>do</sub>) according to the operating distance (D<sub>op</sub>) of the couple (TX<sub>A</sub> – RX<sub>A</sub>) for a Type 4 ESPE.

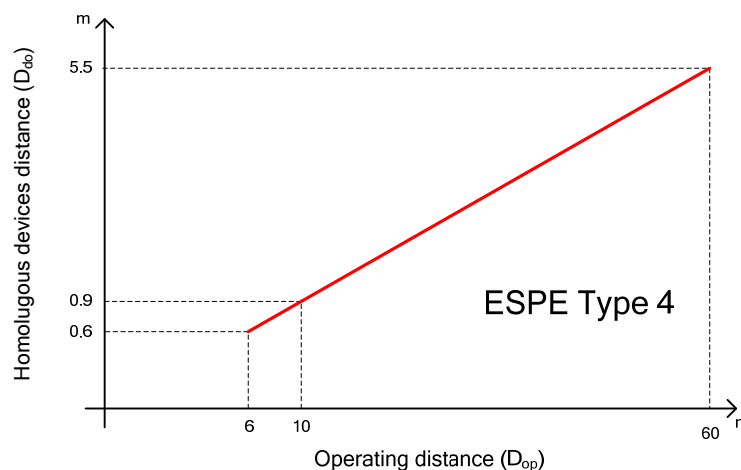

Figure 14

The formula to get D<sub>op</sub> for a Type 4 ESPE is the following:

$$D_{op} \text{ (m)} = \text{operating distance (m)} \times \text{tg } 2\alpha \quad \text{for operating distance} \geq \text{di } 6 \text{ m}$$

Type 2 ESPE

The following graphic shows the distance from the interfering devices ( $D_{do}$ ) according to the operating distance ( $D_{op}$ ) of the couple ( $TX_A - RX_A$ ) for a Type 2 ESPE.

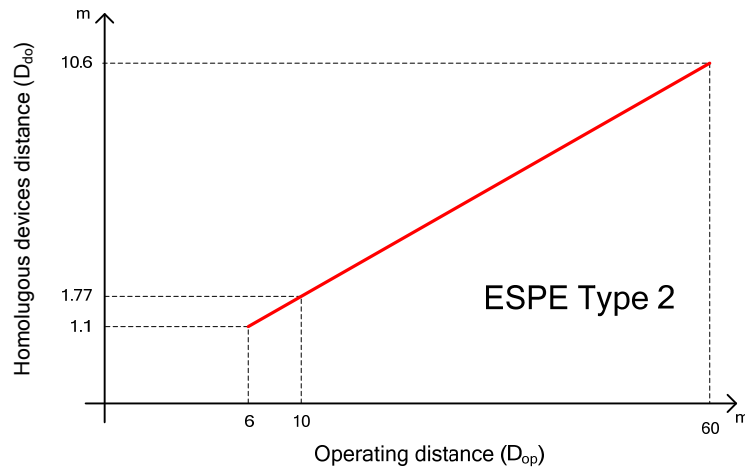

Figure 15

The formula to get  $D_{op}$  for a Type 2 ESPE is the following:

$$D_{op} \text{ (m)} = \text{operating distance (m)} \times \text{tg } 2\alpha \quad \text{for operating distance} \geq \text{di } 6 \text{ m}$$

Installation precautions have to be taken to avoid interference between homologous devices. A typical situation is represented by the installation areas of several adjacent safety devices aligned one next to the other, for example in plants with different machines.

Figure 16 provides some examples:

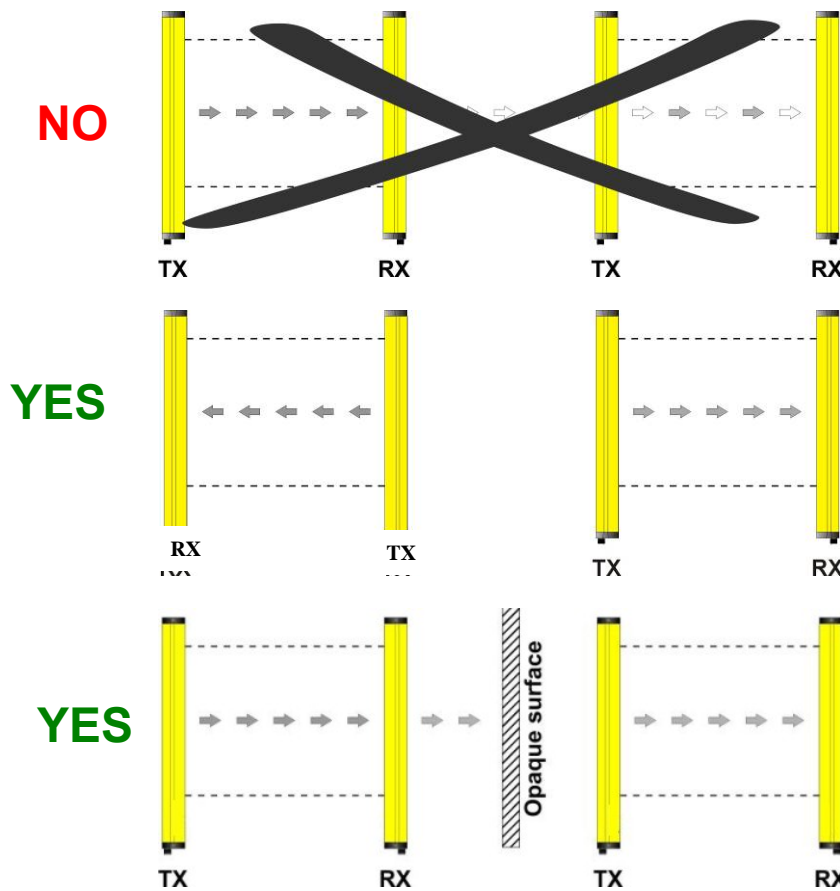

Figure 16

3.2.4. *Emitter and receiver orientation*

The two units shall be assembled parallel each other, with the beams arranged at right angles with the emission and receiving surface, with the connectors orientated towards the same direction and looking at the references on the aluminium profile.

The configurations shown in Figure 18 must be avoided:

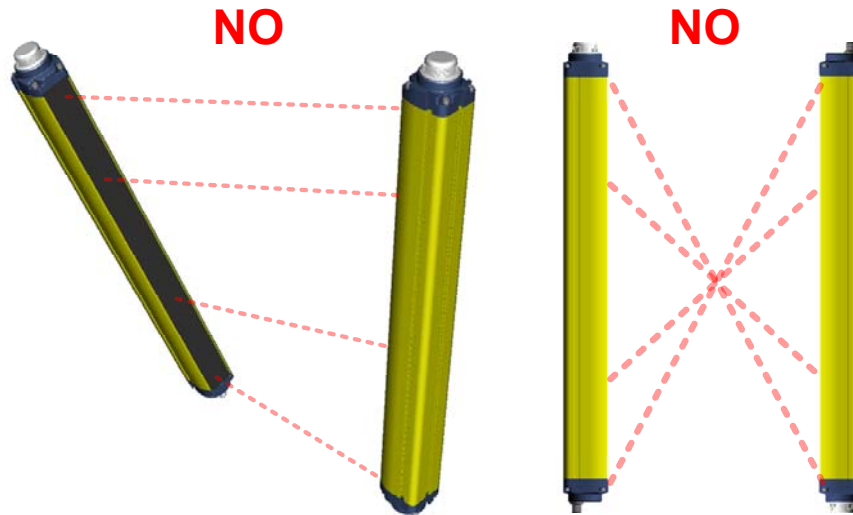

Figure 17

3.2.5. *Use of deviating mirrors*

The control of any dangerous area, with several but adjacent access sides, is possible using only one safety device and well-positioned deviating mirrors (see section 14.4).

Figure 18 shows a possible solution to control three different access sides, using two mirrors placed at 45° respect to the beams.

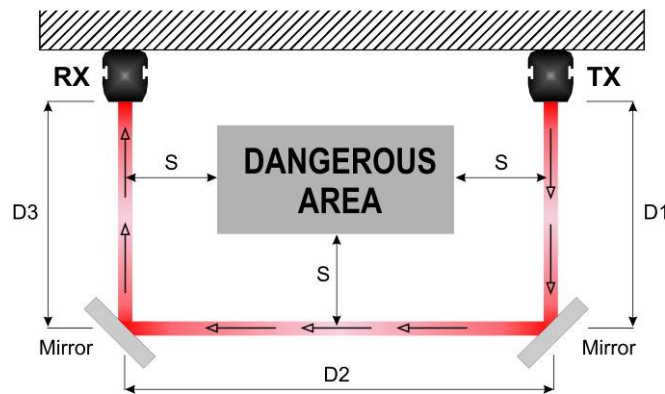

Figure 18

The operator must respect the following precautions when using the deviating mirrors:

- The alignment of the emitter and the receiver can be a very critical operation when deviating mirrors are used. Even very small displacements of the mirror is enough to lose alignment. The use of Datalogic Automation SG-LP laser pointer accessory is recommended under these conditions.
- The minimum safety distance (S) must be respected for each single section of the beams.
- The effective operating range decreases by about 15% by using only one deviating mirror, the percentage further decreases by using 2 or more mirrors (for more details refer to the technical specifications of the mirrors used).

The following table shows the operating distances relating to the number of mirrors used.

Number of mirrors	Operating distance (60 m)
1	51 m
2	43.4 m
3	36.9 m

- Do not use more than three mirrors for each device.
- The presence of dust or dirt on the reflecting surface of the mirror causes a drastic reduction in the range.

The previous values are guaranteed using Datalogic Automation SE-DM series or SG-DM series deviating mirrors.

### 3.2.6. Controls after first installation

The control operations to carry-out after the first installation and before machine start-up are listed hereinafter. The controls must be carried-out by qualified personnel, either directly or under the strict supervision of the person in charge of machinery Safety.

Verify that:

ESPE remains in SAFE state (➡) intercepting the beams along the protected area using the specific test piece (TP-40 for SG4-40 models, TP-40, TP-50, TP-90 for all the other models), following the Figure 19 scheme.

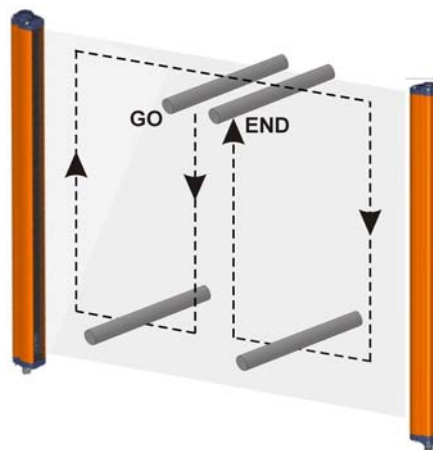

Figure 19

- ESPE has to be correctly aligned, press slightly on the product side in both directions the red LED must not turn on (➡).
- The activation of the TEST function causes the opening of the OSSD outputs (red LED ➡ on and controlled machine stop).
- The response time at machine STOP, including the ESPE and machine response times, must be included in the limits defined in the calculation of the safety distance (refer to section 3 – “INSTALLATION MODE”).
- The safety distance between the dangerous parts and ESPE must comply with the requirements indicated in section 3 – “INSTALLATION MODE”.
- A person must not access or remain between ESPE and the dangerous parts of the machine.
- Access to the dangerous areas of the machine must not be possible from any unprotected area.
- ESPE must not be disturbed by external light sources, ensuring that it remains in NORMAL OPERATION condition for at least 10-15 minutes and, placing the specific test piece in the protected area, in the SAFE state for the same period.
- Verify the correspondence of all the accessory functions, activating them in the different operating conditions.



#### 4. MECHANICAL MOUNTING

The emitting (TX) and receiving (RX) units must be installed with the relevant sensitive surfaces facing each other. The connectors must be positioned on the same side and the distance must be included within the operating range of the model used (see section 13).

The two units must be positioned the most aligned and parallel possible.

The next step is the fine alignment, as shown in section 7 – “ALIGNMENT PROCEDURE”.



SG BODY series light curtains are provided without mounting brackets. It is possible to order separately the accessory kits of brackets described in the following paragraphs depending on the fastening mode required by the particular application. Please refer to section 14 – “ACCESSORIES”.

##### 4.1. Side fixing brackets

As all the Datalogic Automation SG series safety light curtains, the most common way to fix the product is by taking advantage from the two grooves along the sides of the aluminium case, the 90° bracket system is made by ST-5090 + IM-5018 and screws (see Figure 20).

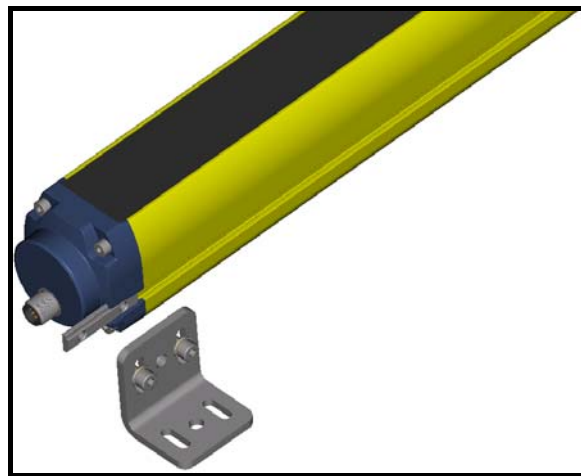

Figure 20

The ST-5090 is a 4 mm thickness sheet metal. The IM-5018 is a double nut M5 tapped obtained by machine tooling (see also paragraph 14.1).

##### 4.2. Rotating brackets

The rotative fixing has been improved and revised due to the size of the caps. Is possible indeed to ensure a 360° rotation around the dedicated cylindrical surfaces designed on the caps themselves. To obtain this is necessary to use the ST-5089, 4 mm thickness sheet metal with a special, dedicated shape. The screw to fix this bracket is the same one used to fix the closing caps, with an M4 nut (see Figure 21). For further informations refer to paragraph 14.2.

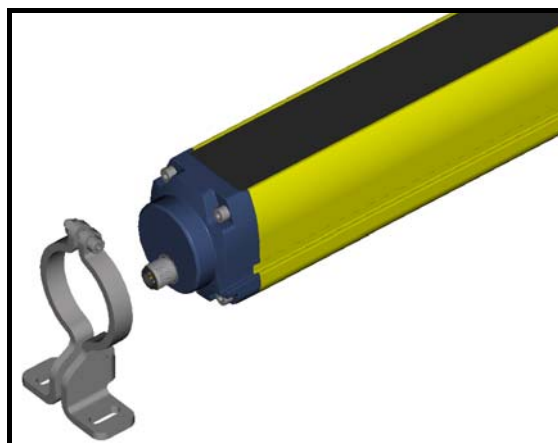

Figure 21

#### 4.3. Bottom fixing brackets

With the SG BODY series has been implemented a new kind of bracket fixing, by using the third groove, on the bottom side of the housing, that allows to use whether the 90° bracket ST-5090 or the new ST-5093 and, in both the cases, the same IM-5018 and screws seen before.

This kind of fixing is also very versatile in order to assembly the product into the new Protective Stands mechanical armor.

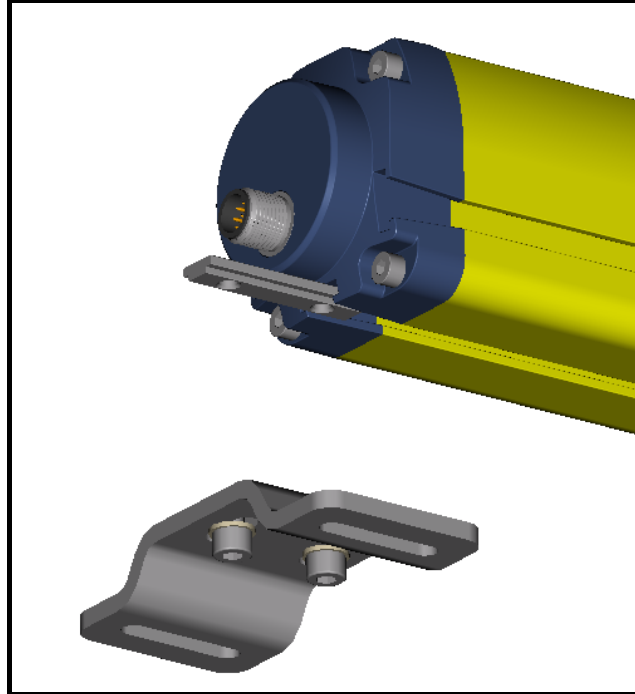

Figure 22

The ST-5093 is a 4 mm thickness sheet metal as well. For further informations refer to paragraph 14.2.

#### 4.4. Vibration dampers

In case of applications with particularly strong vibrations, vibration dampers together with mounting brackets are recommended to reduce the impact of the vibrations (see).

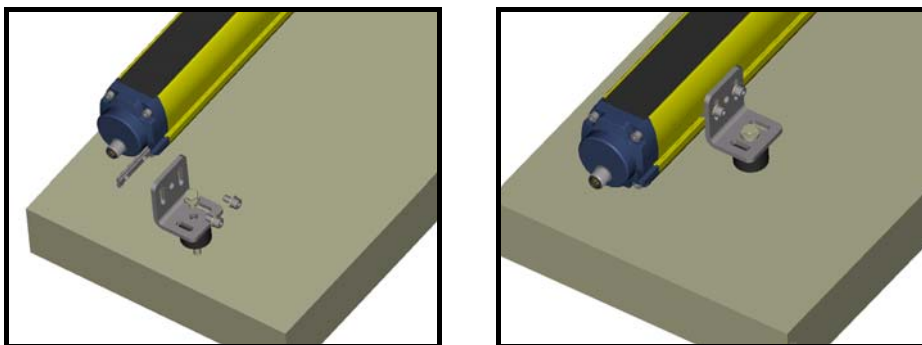

Figure 23

### 5. ELECTRICAL CONNECTIONS AND CONFIGURATION

All electrical connections to the emitting and receiving units are made through male M12 connectors, located on the lower part of the two units.

For receiver a M12 8-poles connector is used, while for emitter a M12 5-poles connector is used.

#### 5.1. Important notes for installation

For the correct functioning of the SG BODY series safety light curtains, the following precautions regarding the electrical connections have to be respected:

- Do not place connection cables in contact with or near high-voltage cables and/or cable undergoing high current variations (e.g. motor power supplies, inverters, etc.);
- Do not connect in the same multi-pole cable the OSSD wires of different light curtains;
- The device is already equipped with internal overvoltage and overcurrent suppression devices. The use of other external components is not recommended.

#### 5.2. Minimal connection

RX	TX
<p><u>Wires configuration: EDM disabled, automatic restart</u></p> <p>The diagram shows two separate wiring configurations. The first configuration shows a terminal connected to +24Vdc, another to 0V, and a third to a normally closed (NC) contact labeled 'RESET/RESTART/RESTART MODE line'. The second configuration shows a terminal connected to +24Vdc, another to 0V or floating, and a third to 'EDM ENABLE line'.</p>	<p>Power supply: 0V, 24V (0-24 Vdc) OTHER lines: floating</p>
<p>Power supply: 0V, 24V (0-24 Vdc) OTHER lines: floating</p>	

#### 5.3. Complete connection list

RX	TX
<p>The diagram shows a circular 8-pole connector with terminals numbered 1 through 8 around the perimeter.</p>	<p>The diagram shows a circular 5-pole connector with terminals numbered 1 through 5 around the perimeter.</p>
<p>M12 8 poles: 1 = white = RESET/RESTART/RESTART MODE 2 = brown = 24V 3 = green = EDM ENABLE 4 = yellow = EDM 5 = grey = OSSD1 6 = pink = OSSD2 7 = blue = 0V 8 = red = EARTH</p>	<p>M12 5 poles: 1 = brown = 24V 2 = white = TEST 3 = blue = 0V 4 = black = EARTH 5 = grey = N.C.</p>

**5.4. Restart mode and Reset/Restart button connection**

The Restart mode and Reset/Restart wire must be connected through a N.C. button to the 0V or 24V from the power supply of the ESPE to select, respectively, manual restart or automatic restart.

The Reset/Restart wire can be used to enter alignment function, when N.C. button is pressed at start-up.

 The RESET/RESTART button must be located in such a way that the operator can check the protected area during any reset operation.

**5.5. Test button connection**

- The TEST wire must be connected through a N.O. button to the 24V supply of the ESPE.

 The TEST button must be located in such a way that the operator can check the protected area during any test.

**5.6. External relays connection**

Example: connection to the safety relay.

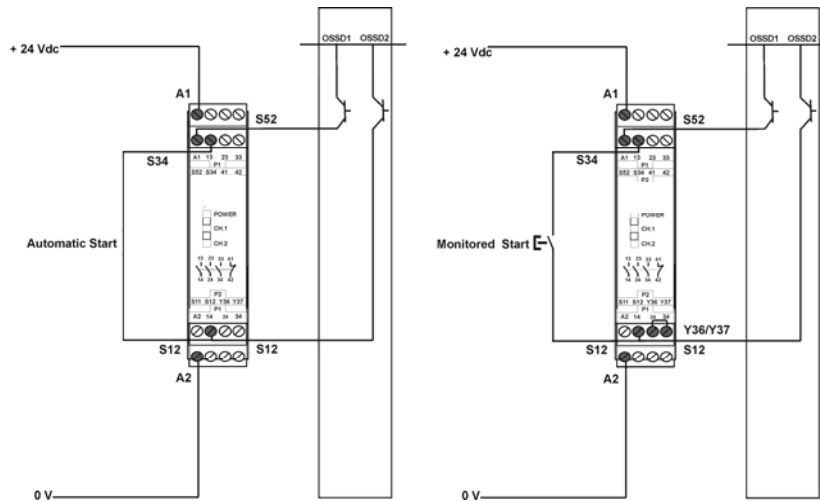

**Figure 24**

The previous figure shows the connection between the safety light curtains and the safety relay of the SE-SR2 series functioning in the Automatic Restart mode (left side) and Manual Restart with monitoring (right side).

- Do not use varistors, RC circuits or LEDs in parallel at relay inputs or in series at OSSD outputs.
- The OSSD1 and OSSD2 safety contacts cannot be connected in series or in parallel, but must be used separately (Figure 25), conforming to the plant's safety requirements.

If one of these configurations is erroneously used, the device enters into the output failure condition (see section 8 – “DIAGNOSTICS”).

- Connect both OSSDs to the activating device. Failure to connect an OSSD to the activating device jeopardises the system safety degree that the light curtain has to control.

YES

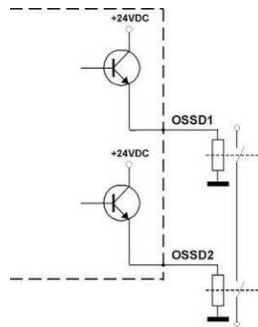

Figure 25

NO

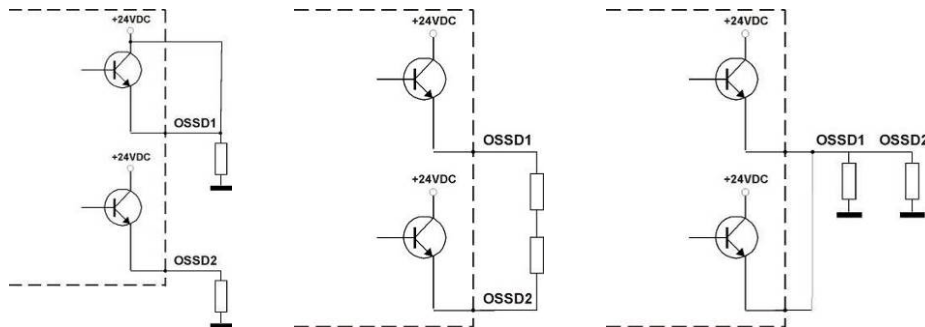

Figure 26

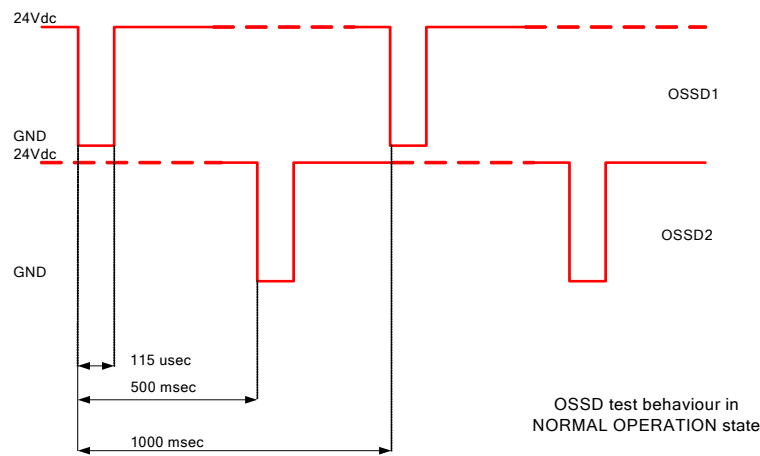

Figure 27

**5.7. EDM ENABLE input connection**

The EDM ENABLE wire must be connected to 0V or 24V from the power supply of the ESPE, respectively, to enable or to disable EDM function. Floating line level is the same as 0V.

**5.8. EDM control connection**

The EDM wire has to be connected to a 24 Vdc normally closed contact, before powering. The monitoring function, if selected, is not activated if at powering the wire is not correctly connected; in this case the light curtain enters in a failure condition.

**5.9. Earth connection**

The SG BODY safety light curtain has to be connected as a protective class III equipment (SELV/PELV power supply), like in the table.

Electrical protection	layout connection	note
class III	SELV/PELV	---

A functional earth is available on a line of the M12 connector on TX and RX equipment. User can optionally connect or leave floating the functional earth in order to achieve in own application a best compliance with electromagnetic Interferences.

**6. FUNCTIONING MODE**

**6.1. Standard configuration**

Line	Layout connection	Behaviour
TEST		Test not active
RESET/RESTART/ RESTART MODE		Automatic restart
RESET/RESTART/ RESTART MODE		Manual restart
EDM		(EDM active) ENABLE:
EDM ENABLE		EDM enabled
OSSDs		

**6.2. Reset function**

The RX light curtain has a RESET function that is activated consequently to an internal failure. The operator has to press the NC RESET button that resetting the break condition and thus the ESPE can return to a normal functioning behaviour .

The button has to be kept pressed for at least 5 seconds in one of the following conditions:

- Output failure;
- Optic failure;
- EDM test function failure;

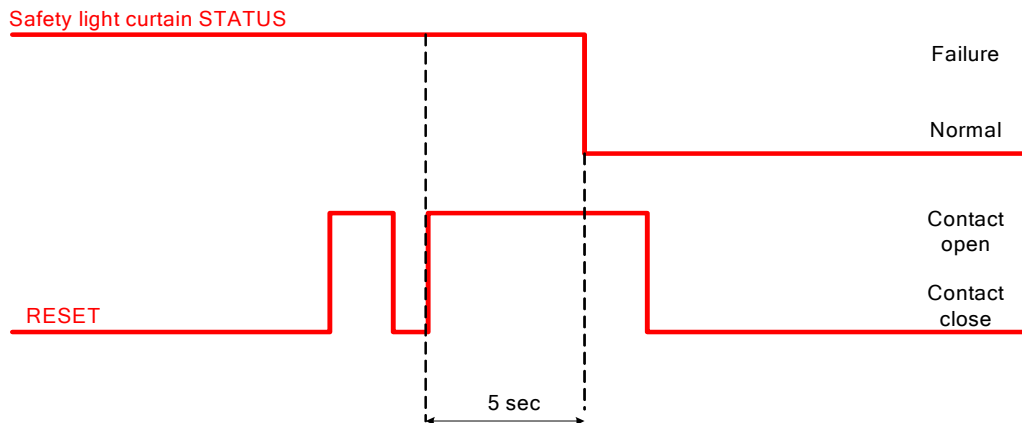

If the error is not removed, the light curtain goes in the failure configuration (for all failures) yet.

Notes: the micro controller failure is a non-restorable failure. In this case is necessary a “turn OFF-turn ON action” to return to a normal behavior. This is also valid for the restart selection failure.

**6.3. Restart mode selection function**

The interruption of a beam due to an opaque object causes the opening of OSSD outputs and the stop of the safety light curtain, SAFE condition ➡ I.

ESPE standard operation can be reset to NORMAL OPERATION condition (OSSD safety contact closing condition, ➡ ) in two different ways:

Automatic Restart: after activation, ESPE resets to NORMAL OPERATION condition once the object has been removed from the controlled area.

Manual Restart: after activation, ESPE resets to NORMAL OPERATION condition only once the Restart function has been enabled and provided that the object has been removed from the controlled area (see Figure 28). This condition, called “restart interlock”, is signalled on the display (see paragraph 8.2 – “Diagnostic messages”).





**WARNING:** Carefully assess risk conditions and restart modes.  
 In applications protecting access to dangerous areas, the automatic restart mode is potentially unsafe if it allows the operator to pass completely beyond the sensitive area. In this case, the manual restart or, for example, the manual restart of the SE-SR2 relay (paragraph 5.6 – “External relays connection”) is necessary.

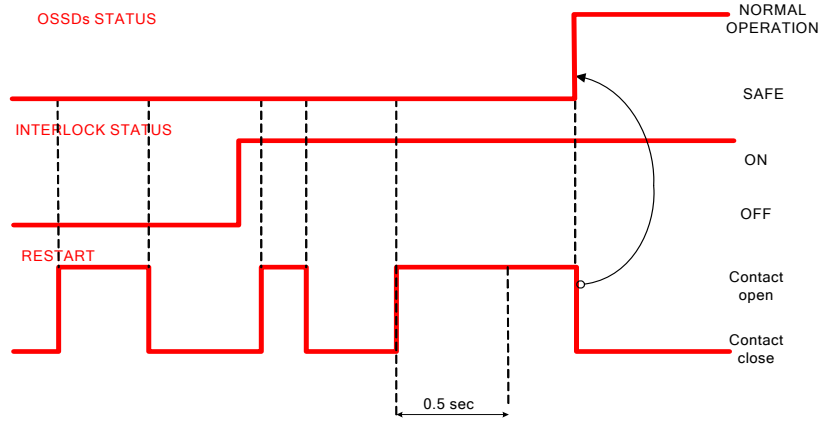

**Figure 28 – Time chart for manual restart**

Select either automatic or manual restart by connecting pin of RX connector (see section 5 – “ELECTRICAL CONNECTIONS AND CONFIGURATION”).

**6.4. EDM function**

The light curtain has a function for monitoring actuation external devices (EDM). This function can be enabled or deactivated by pin of RX connector (see section 5 – “ELECTRICAL CONNECTIONS AND CONFIGURATION”).

EDM deactivated:

Disconnect or connect to 0V EDM input pin of RX connector.

EDM enabled:

Connect EDM input pin of RX connector (see section 5 – “ELECTRICAL CONNECTIONS AND CONFIGURATION”) to a 24 VDC normally closed contacts of the device to be monitored (see Figure 29).

**NOTE:** The decimal dot on the display shows that the function is enabled.

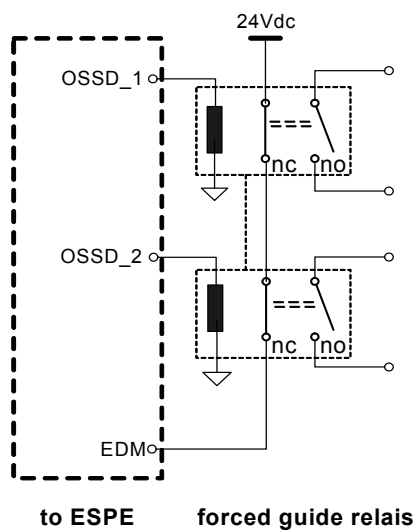

**Figure 29**

The function controls the NC contact switching according to the changes of the OSSD status. The timing diagram below explains the relationship between the cause (OSSDs) and the effect (EDM), with the maximum permissible delay.

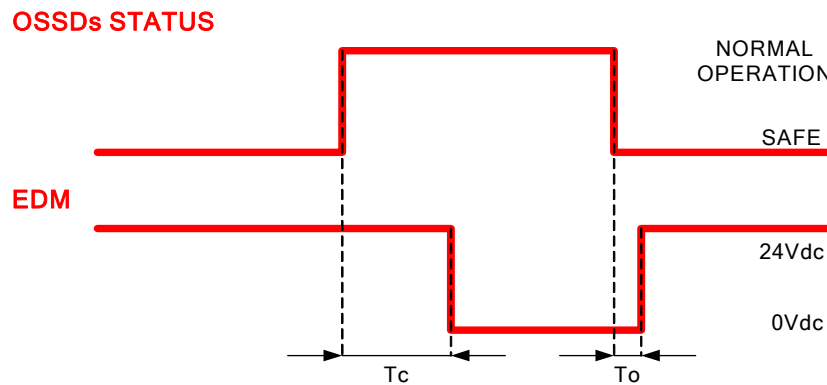

Figure 30

$T_c \geq 350$  msec time after the OSSD OFF-ON passage when EDM is carried-out;  
 $T_o \geq 100$  msec time after the OSSD ON-OFF passage when EDM is carried-out.

(two different times for the mechanical contact driven by a spring).

**6.5. Alignment function**

SG BODY series light curtains are fitted with a system which informs the user about reached alignment degree. The ALIGNMENT function also can be activated by simply pressing the external normally closed push-button link to RESET/RESTART/RESTART MODE line (see section 5 – “ELECTRICAL CONNECTIONS AND CONFIGURATION”) for at least 0.5 sec at start-up, as shown in the timing diagram of Figure 31.

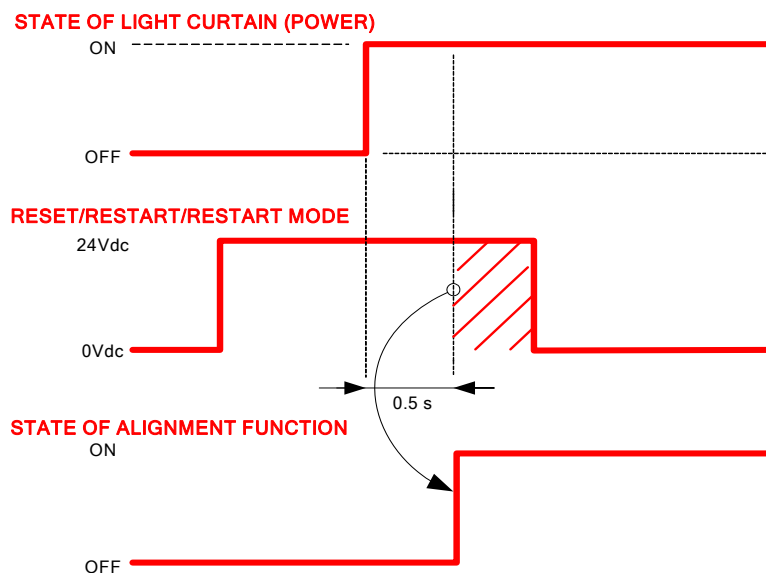
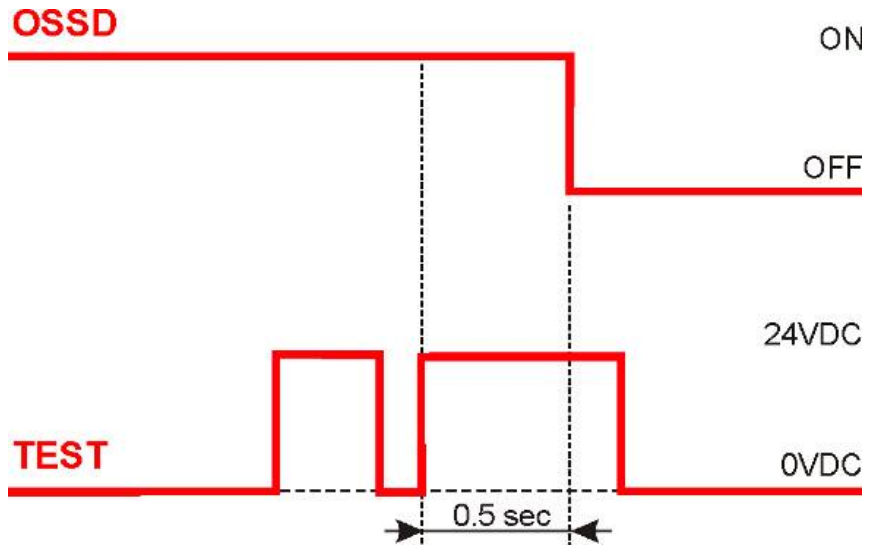

Figure 31

When a good state of alignment is reached a power OFF and a power ON operation carry back the ESPE in normal operation (OSSDs in ON state). In the alignment mode the OSSDs are OFF.

**6.6. Test**

The TEST function can be activated by simply pressing the external normal open push-button, connected to the M12 TX connector (see section 5 – “ELECTRICAL CONNECTIONS AND CONFIGURATION”), for at least 0.5 seconds as shown in the following timing diagram.



### 7. ALIGNMENT PROCEDURE

The good alignment between the emitting and the receiving unit of the ESPE is necessary to obtain the correct behaviour of the light curtain. A good alignment avoid a not steady light curtain status (OSSDs flicker on→off and vice versa) due to dust or vibration.

The alignment is perfect if the optic axes of the first and the last emitting unit's beams coincide with the optic axes of the corresponding elements of the receiving unit.

It is important to define the means of symbol drawn on optic side of light curtain.

The direction of arrows associated to the two yellow led are correlated to the first and the last beam, referring the position of M12 connector. Signals are clearly identified through symbols allowing their immediate reading, independent of bars directions; a short description of LEDs signals proves nevertheless necessary so as to avoid misunderstandings.

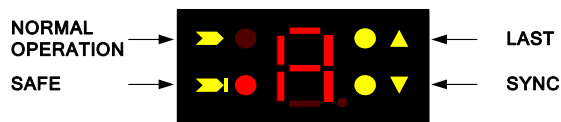

Figure 32

Figure 33 shows that the first beam is the nearest beam to M12 connector; the last beam is the farrest beam to M12 connector. The first beam is the synchronism beam also.

The standard installation described hereinafter is the one shown in Figure 33, i.e. with the bar assembled with the connectors pointing down.

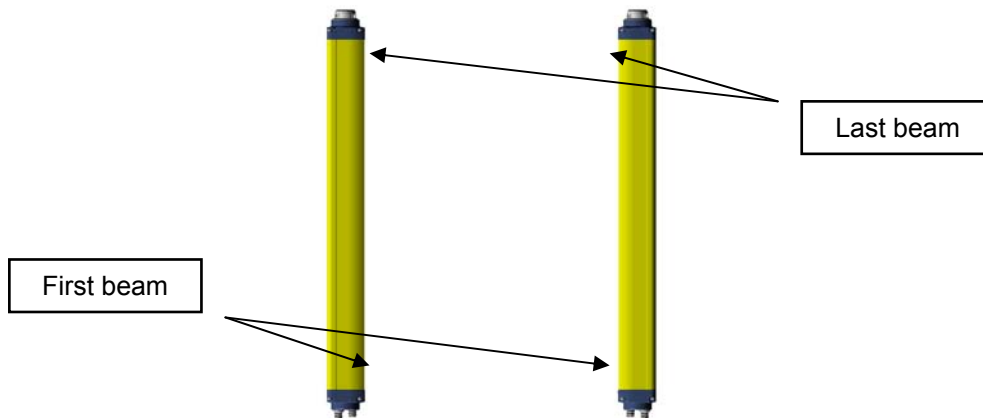

Figure 33

An one digit display can inform the user about the level of alignment of the array of beams.

As operating distance increase, the SG-LP laser pointer tool attached on RX or TX unit can be used to help the user to obtain the best alignment (see Figure 34).

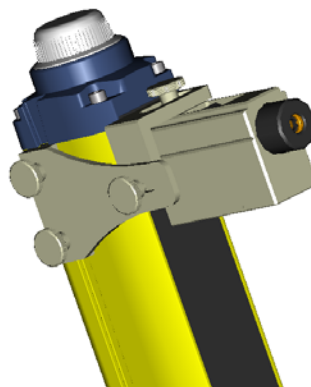

Figure 34

**7.1. Light curtain alignment procedure**

The light curtain alignment can be effected only after having completed the mechanical installation and the electrical connections as described above. Compare alignment results with those given in the following table.

To enter alignment mode see paragraph 6.5 – “Alignment function”.



**ATTENTION:** in alignment mode the OSSDs of the light curtain are in OFF state

Visualization	Alignment state	Alignment quality	OSSD state out of alignment-function
	No sync → check 1 <sup>st</sup> beam	Bad	OFF
	Last beam isn't aligned	Bad	OFF
	One or more intermediate beam is not aligned	Bad	OFF
		Good	ON
	Every beam over the lower threshold and up to 25% of beams over the upper threshold		ON
	Every beam over the lower threshold and up to 50 % of beam over the upper threshold		ON
	Every beam over the lower threshold and up to 75% of beam over the upper threshold		ON
	Every beam over the lower threshold and up to 100% of beam over the upper threshold	Excellent	ON

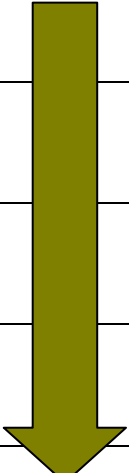

1. Keep the receiver in a steady position and set the emitter until the yellow LED (▼ SYNC) is OFF. This condition shows the alignment of the first synchronisation beam.
2. Rotate the emitter, pivoting on the lower optics axis, until the yellow LED (▲ LAST) is OFF.

NOTE: Ensure that the green LED (➡ NORMAL OPERATION) is steady ON.

3. Delimit the area in which the green LED (➡) is steady through some micro adjustments - for the first and then for the second unit - so to have the maximum alignment (4) and then place both units in the centre of this area.
4. Fix the two units firmly using brackets. Verify that the green LED (➡) on the RX unit is ON and beams are not interrupted, then verify that the red LED SAFE (➡) turns ON if even

one single beam is interrupted (condition where an object has been detected). This verification shall be made with the special cylindrical “Test Piece” having a size suitable to the resolution of the device used (refer paragraph 3.2.6 – “Controls after first installation”).

5. Switch OFF and ON the device in normal operating mode.

The alignment level is monitored also during device normal operating mode, and is visualized by a bar graph shown on the user interface. Once the curtain has been aligned and correctly fastened, the display signal is useful to check the alignment and to view any change in the environmental conditions (presence of dust, light disturbance and so on). The behavior is resumed in the next table.

Visualization	Alignment state	Alignment quality
	every beam over the lower threshold and up to 25% of beams over the upper threshold	
	every beam over the lower threshold and up to 50 % of beam over the upper threshold	
	every beam over the lower threshold and up to 75% of beam over the upper threshold	
	every beam over the lower threshold and up to 100% of beam over the upper threshold	

## 8. DIAGNOSTICS

### 8.1. User interface

A user interface aids the customer to control and check the state of the light curtain, for alignment mode, normal operation and for troubleshooting activity. User interface is composed by for LEDs on the receiver and two LEDs on the emitter and an one-digit display present on both receiver and emitter unit.

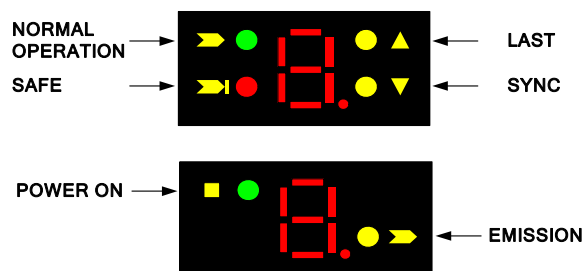

Figure 35

8.2. Diagnostic messages

8.2.1. RX side



The table completely explains all the visualization informations except those relative to the alignment function (see par. 7.1 – “Light curtain alignment procedure”).

Visualization	Status	Description	Action
	INTERLOCK	Free beams, OSSDs OFF	User can take device in normal operation activating restart line.
	INTERLOCK	Interrupted beams, OSSDs OFF	User must free beams path before activating restart line.
	NORMAL OPERATION	OSSDs ON	
	SAFE	OSSDs OFF	
	NORMAL OPERATION, SAFE, INTERLOCK	EDM function active	
	NORMAL OPERATION, SAFE, INTERLOCK	EDM function not active	
	FAILURE LOCKOUT (recoverable)	Failure on one or both OSSDs, OSSDs OFF	User must activate RESET line. If ESPE does not reset user must contact Datalogic Automation Technical Support.
	FAILURE LOCKOUT (not recoverable)	Microcontroller failure, OSSDs OFF	User must turn OFF/ON ESPE. If the problem persists user must contact Datalogic Automation Technical Support.
	FAILURE LOCKOUT (recoverable)	Optical failure, OSSDs OFF	User must activate RESET line. If ESPE does not reset user must contact Datalogic Automation Technical Support.
	FAILURE LOCKOUT (recoverable)	EDM failure, OSSDs OFF	User must check EDM ENABLE line or dip-switches, EDM line, external switching device and activate RESET line. If ESPE does not reset user must contact Datalogic Automation Technical Support.
	ESPE OFF	Power supply failure, OSSDs OFF	User must check power supply connection. If the problem persists user must contact Datalogic Automation Technical Support.

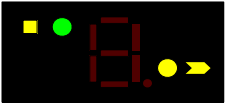
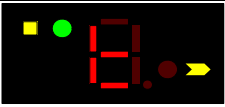
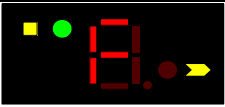
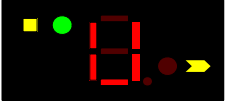
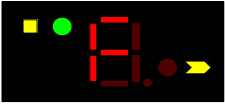
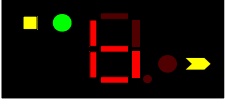

8.2.2. TX side

The table completely explains all the visualization informations.

Visualization	Status	Description	Action
	EMISSION	Emission, No code	
	TEST	No Emission	
 	FAILURE LOCKOUT (not recoverable)	Microcontroller failure	User must turn OFF/ON ESPE. If the problem persists user must contact Datalogic Automation Technical Support.
 	FAILURE LOCKOUT (not recoverable)	Optical failure	User must turn OFF/ON ESPE. If the problem persists user must contact Datalogic Automation Technical Support.
	ESPE OFF	Power supply failure	User must check power supply connection. If the problem persists user must contact Datalogic Automation Technical Support.

9. PERIODICAL MAINTENANCE AND WARRANTY

The following is a list of recommended check and maintenance operations that should be periodically carried-out by qualified personnel (see also paragraph □ – “Do not use more than three mirrors for each device.

The presence of dust or dirt on the reflecting surface of the mirror causes a drastic reduction in the range.

The previous values are guaranteed using Datalogic Automation SE-DM series or SG-DM series deviating mirrors.

Controls after first installation”)

Check that:

- The ESPE stays in SAFE state (➤) during beam interruption along the entire protected area, using the specific Test Piece (TP-40 for SG4-40 models, TP-40, TP-50, TP-90 for all the other models), according to the Figure 19 scheme.
- The ESPE is correctly aligned. Press slightly product side, in both directions and the red LED (➤) must not turn ON.
- Enabling the TEST function, the OSSD outputs should open (the red LED ➤ is ON and the controlled machine stops).
- The response time upon machine STOP (including response time of the ESPE and of the machine) is within the limits defined for the calculation of the safety distance (see section 3 – “INSTALLATION MODE”).
- The safety distance between the dangerous areas and the ESPE are in accordance with the instructions included in section 3 – “INSTALLATION MODE”.
- Access of a person between ESPE and machine dangerous parts is not possible nor is it possible for him/her to stay there.
- Access to the dangerous area of the machine from any unprotected area is not possible.
- The ESPE and the external electrical connections are not damaged.

The frequency of checks depends on the particular application and on the operating conditions of the safety light curtain.

### 9.1. General information and useful data

Safety MUST be a part of our conscience.

The safety devices fulfil their safety function only if they are correctly installed, in accordance with the Standards in force. If you are not certain to have the expertise necessary to install the device in the correct way, Datalogic Automation Technical Support is at your disposal to carry out the installation.

The device uses fuses that are not self-resetting. Consequently, in presence of short-circuits causing the cut-off of these fuses, both units shall be sent to Datalogic Automation Technical Support department.

A power failure caused by interferences may cause the temporary opening of the outputs, but the safe functioning of the light curtain will not be compromised.

## 9.2. Warranty

Datalogic Automation guarantees each brand new SG BODY system, under standard use conditions, against manufacturing defects in material and workmanship for a period of 36 (thirty-six) months from the date of manufacturing.

Datalogic Automation will not be liable for any damages to persons and things caused by wrong installation modes or device use.

Warranty validity is subject to the following conditions:

- User shall notify Datalogic Automation the failure within thirty-six months from product manufacturing date.
- Failure or malfunction shall not have been originated directly or indirectly by:
  - use for unsuitable purposes;
  - failure to comply with the intended use prescriptions;
  - negligence, unskillfulness, wrong maintenance;
  - repairing, changes, adaptations not made by Datalogic Automation personnel, tampering with the device, etc.;
  - accidents or crashes (even due to transportation or by force majeure causes);
  - other causes not depending from Datalogic Automation

If the device does not work, send both units (receiver and emitter) to Datalogic Automation.

The Customer is responsible for all transport charges and damage risks or material loss during transport, unless otherwise agreed.

All replaced products and parts become a property of Datalogic Automation.

Datalogic Automation does not accept any warranty or right other than the above-described ones. No requests for compensation for expenses, activities stop or other factors or circumstances somehow connected to the failure of the product or one of its parts to operate cannot be put forward for any reason.



In case of problems, please contact DATALOGIC AUTOMATION Service Department.

### Technical Support

Tel.: +39 051 6765611

Fax.: +39 051 6759324

## 10. DEVICE MAINTENANCE

SG BODY safety light curtains do not require special maintenance operations.

To avoid the reduction of the operating distance, optic protective front surfaces must be cleaned at regular intervals.

Use soft cotton cloths dampened in water.

Do not apply too much pressure on the surface in order to avoid making it opaque.

Please do not use on plastic surfaces or on light curtain painted surfaces:

- alcohol or solvents
- wool or synthetic cloths
- paper or other abrasive materials

### 10.1. Product disposal

Under current Italian and European laws, Datalogic Automation is not obliged to take care of product disposal at the end of its life.

Datalogic Automation recommends to dispose of the product in compliance with local laws or contact authorised waste collection centres.

## 11. TECHNICAL DATA

<b>Electrical Data</b>	
Power supply	24 Vdc $\pm$ 20%
Emitter consumption (TX)	2.5 W max
Receiver consumption (RX)	4.0 W max (without load)
Outputs:	2 PNP outputs short-circuit protection (1.4 A @55°C)
Output current:	0.5 A max / each output
Output voltage - ON min:	Power supply value less 1 V
Output voltage - OFF max:	0.2 V
Output capacitive load	2.2 $\mu$ F @24Vdc
Response time:	From 11 to 24 ms See section 13 – "ORDER DATA"
Protected height:	from 500 mm to 1200 mm See section 13 – "ORDER DATA"
Safety category:	Type 4 / Type 2 (ref. EN 61496-1) SIL 3 / SIL 2 (ref. EN 61508) SIL CL 3 / SIL CL 2 (ref. EN 62061) PL e Cat. 4 / PL d Cat. 2 (ref. IEC 13849-1 2008) See section 13 – "ORDER DATA"
Auxiliary functions:	Reset, Restart selection, Alignment, EDM, Test
Electrical protection – Layout connection:	class III – SELV/PELV
Connections:	M12 5, 8 poles
Cable length ( for power supply):	70 m. max
Pollution degree	2
<b>Optical Data</b>	
Light source:	Infrared LED (950 nm wavelength )
Resolution:	40 mm 319,75 mm 419,75 mm 519,75 mm
Beam spacing	20 mm 300 mm 400 mm 500 mm
Operating distance:	For 0.5 to 60 mt See section 13 – "ORDER DATA"
Ambient light rejection:	IEC 61496-2
<b>Mechanical and environmental data</b>	
Operating temperature:	0...55°C
Storage temperature:	-25...+ 70 °C
Temperature class:	T6
Humidity:	15...95 % (no condensation)
Water protection grade:	IP 65 (EN 60529)
Vibrations:	0.35 mm width, 10...55 Hz frequency, 20 sweep for each axis, 1 octave/min (EN 60068-2-6)
Shock resistance:	16 ms (10g) 1.000 shock for each axis (EN 60068-2-29)
Housing material:	Painted aluminium (yellow RAL 1003)
Caps material:	PBT Valox 508 (pantone 072-CVC)
Front glass material:	PMMA
Connections:	M12 connector
Weight:	SGx-B2-050-OO-W-C: 1,3 Kg SGx-B3-080-OO-W-C: 1,8 Kg SGx-B4-090-OO-W-C: 2,1 Kg SGx-B4-120-OO-W-C: 2,6 Kg SG4-40-xxx-OO-E: 2,5 Kg/mt (single bar---not packaged)  x = ESPE Type: 2,4

## 12. DIMENSIONS

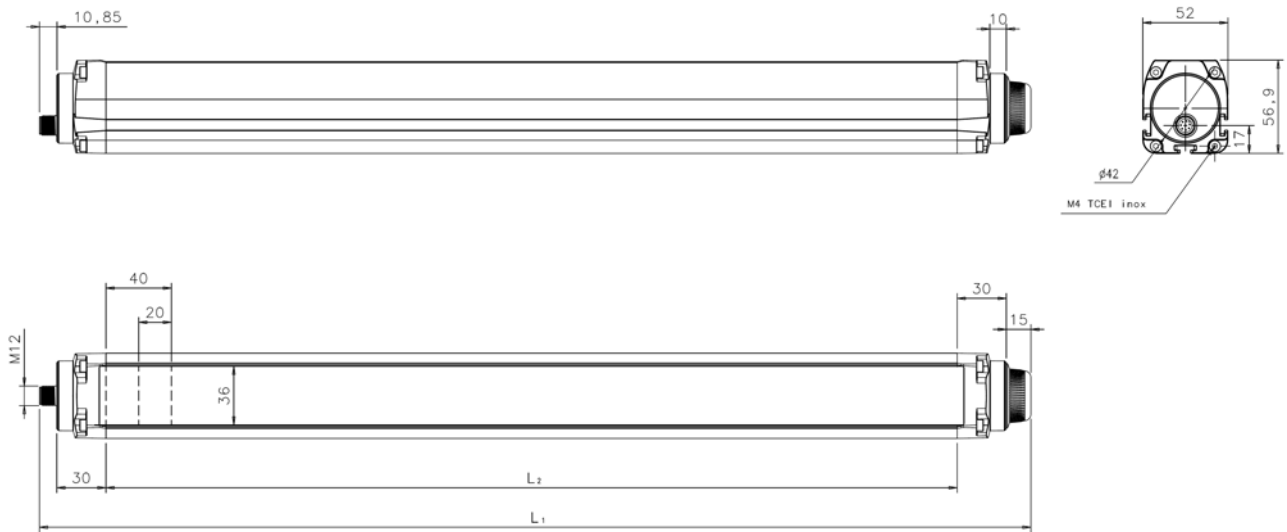

Model	L1 [mm]	L2 [mm]
SGx-B2-050-OO-E	606,35	520,5
SGx-B3-080-OO-E	906,35	820,5
SGx-B4-090-OO-E	1006,35	920,5
SGx-B4-120-OO-E	1306,35	1220,5
SG4-40-060-OO-E	783,35	700,5
SG4-40-090-OO-E	1083,35	1000,5
SG4-40-120-OO-E	1383,35	1300,5

x = ESPE Type: 2,4

### 13. ORDER DATA

Description	Protected height (mm)	Beams (Nr.)	Resolution (mm)	Response time (msec)	Interaxis (mm)	Operating Distance (m)	Code
SG2-B2-050-OO-E	500	2	519,75	12	500	6..60	957851240
SG2-B3-080-OO-E	800	3	419,75	13	400	6..60	957851250
SG2-B4-090-OO-E	900	4	319,75	14	300	6..60	957851260
SG2-B4-120-OO-E	1200	4	419,75	14	400	6..60	957851270
SG4-B2-050-OO-E	500	2	519,75	12	500	6..60	957851280
SG4-B3-080-OO-E	800	3	419,75	13	400	6..60	957851290
SG4-B4-090-OO-E	900	4	319,75	14	300	6..60	957851300
SG4-B4-120-OO-E	1200	4	419,75	14	400	6..60	957851310
SG4-40-060-OO-E	660	33	40	21	20	6..60	957851570
SG4-40-090-OO-E	960	48	40	24	20	6..60	957851580
SG4-40-120-OO-E	1260	63	40	27	20	6..60	957851590

Description	EN ISO 13849-1				PFHd (1/h)	T1 (years)	MTTFd (years)	DC	SFF	HFT
	PL	CAT	SIL	SIL CL						
SG2-B2-050-OO-E	d	2	2	2	1,19E-08	20	317	96,70%	98,00%	0
SG2-B3-080-OO-E	d	2	2	2	1,19E-08	20	317	96,70%	98,00%	0
SG2-B4-090-OO-E	d	2	2	2	1,19E-08	20	317	96,70%	98,00%	0
SG2-B4-120-OO-E	d	2	2	2	1,19E-08	20	317	96,70%	98,00%	0
SG4-B2-050-OO-E	e	4	3	3	1,10E-08	20	353	96,40%	97,90%	1
SG4-B3-080-OO-E	e	4	3	3	1,10E-08	20	353	96,40%	97,90%	1
SG4-B4-090-OO-E	e	4	3	3	1,10E-08	20	353	96,40%	97,90%	1
SG4-B4-120-OO-E	e	4	3	3	1,10E-08	20	353	96,40%	97,90%	1
SG4-40-060-OO-E	e	4	3	3	1,95E-08	20	98	98,30%	98,90%	1
SG4-40-090-OO-E	e	4	3	3	1,95E-08	20	98	98,30%	98,90%	1
SG4-40-120-OO-E	e	4	3	3	1,95E-08	20	98	98,30%	98,90%	1

### 14. ACCESSORIES

#### 14.1. Side fixing bracket

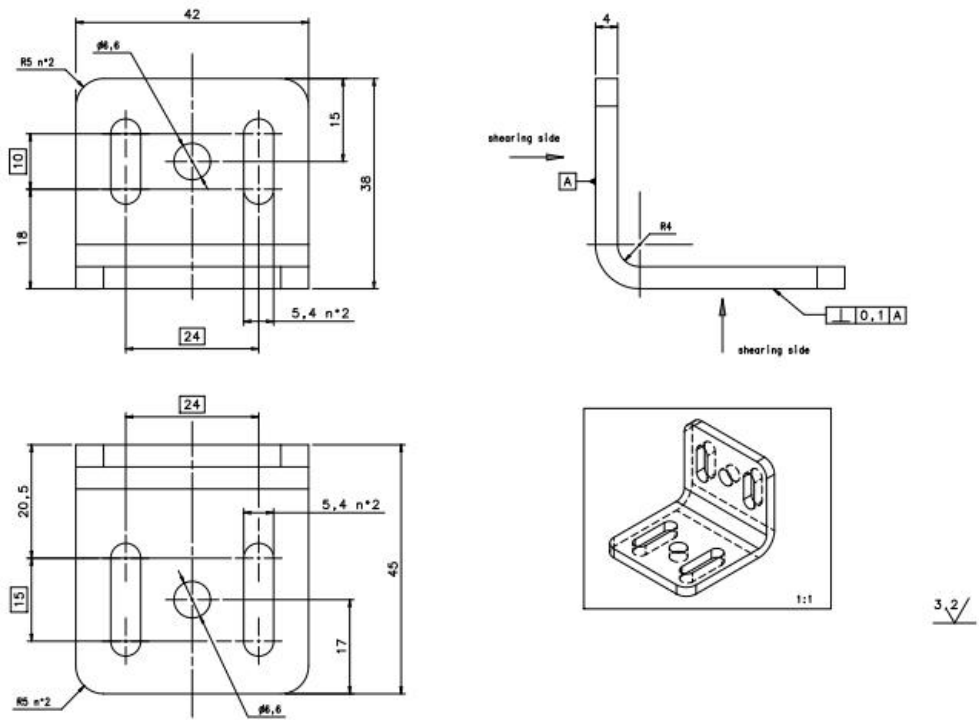
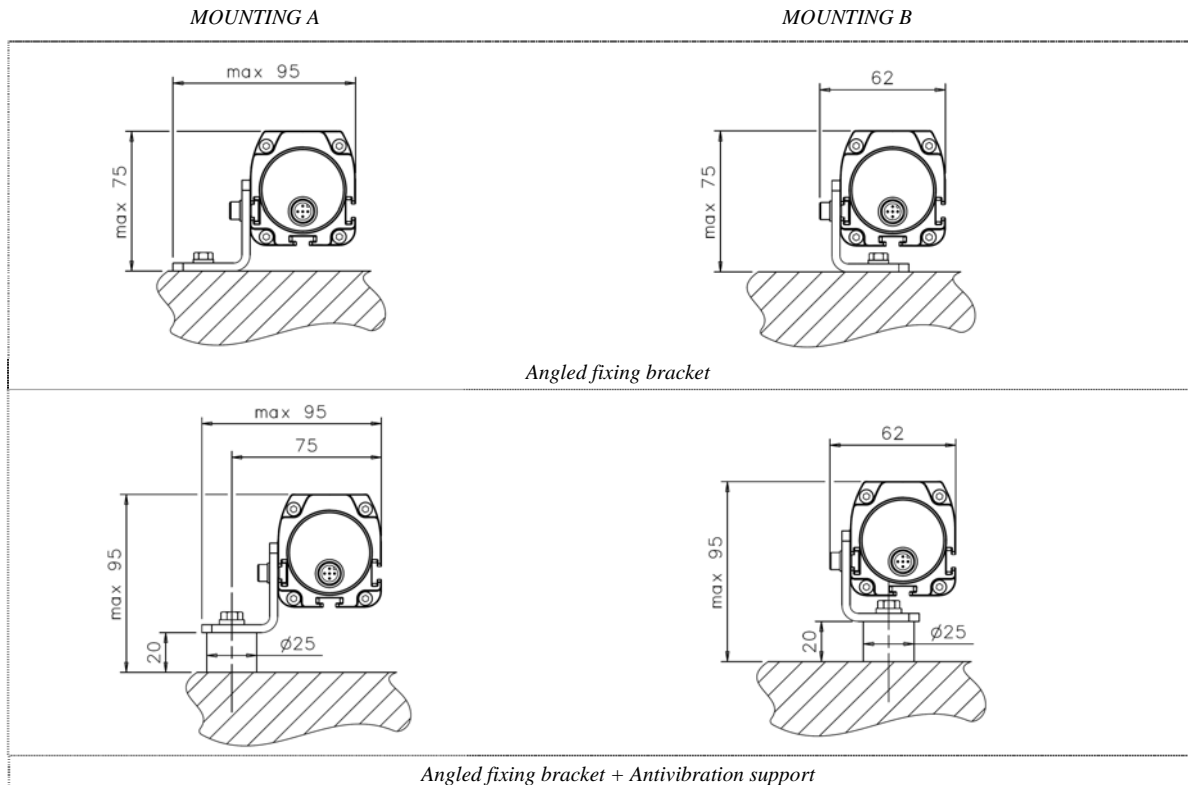

Figure 36

14.1.1. Side fixing bracket mounting



MODEL	DESCRIPTION	CODE
ST-K4STD-SG BODY BIG	Fixing brackets for angle mounting (4 pc kit)	95ASE1950
ST-K4AV	Antivibration support (4 pc kit)	95ACC1700
ST-K6AV	Antivibration support (6 pc kit)	95ACC1710

The recommended mounting positions according to the light curtain length are shown in Figure 37 and in the subsequent table.

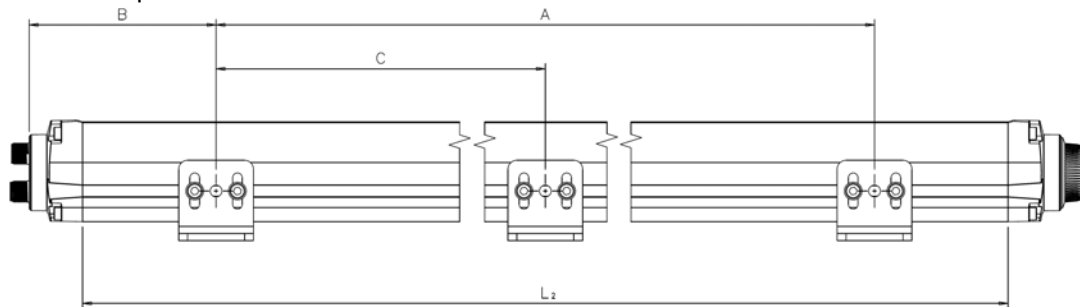

Figure 37

Description	L <sub>2</sub> [mm]	A [mm]	B [mm]	C [mm]	Code
SG2-B2-050-00-E	520,5	320,5	100	-	957851240
SG2-B3-080-00-E	820,5	370,5	125	-	957851250
SG2-B4-090-00-E	920,5	620,5	150	-	957851260
SG2-B4-120-00-E	1220,5	1020,5	100	510,25	957851270
SG4-B2-050-00-E	520,5	320,5	100	-	957851280
SG4-B3-080-00-E	820,5	370,5	125	-	957851290
SG4-B4-090-00-E	920,5	620,5	150	-	957851300
SG4-B4-120-00-E	1220,5	1020,5	100	510,25	957851310
SG4-40-060-00-E	700,5	420,5	140	-	957851570
SG4-40-090-00-E	1000,5	770,5	115	-	957851580



SG4-40-120-00-E	1300,5	1120,5	90	560,25	957851590
-----------------	--------	--------	----	--------	-----------

**14.2. Rotative fixing bracket**

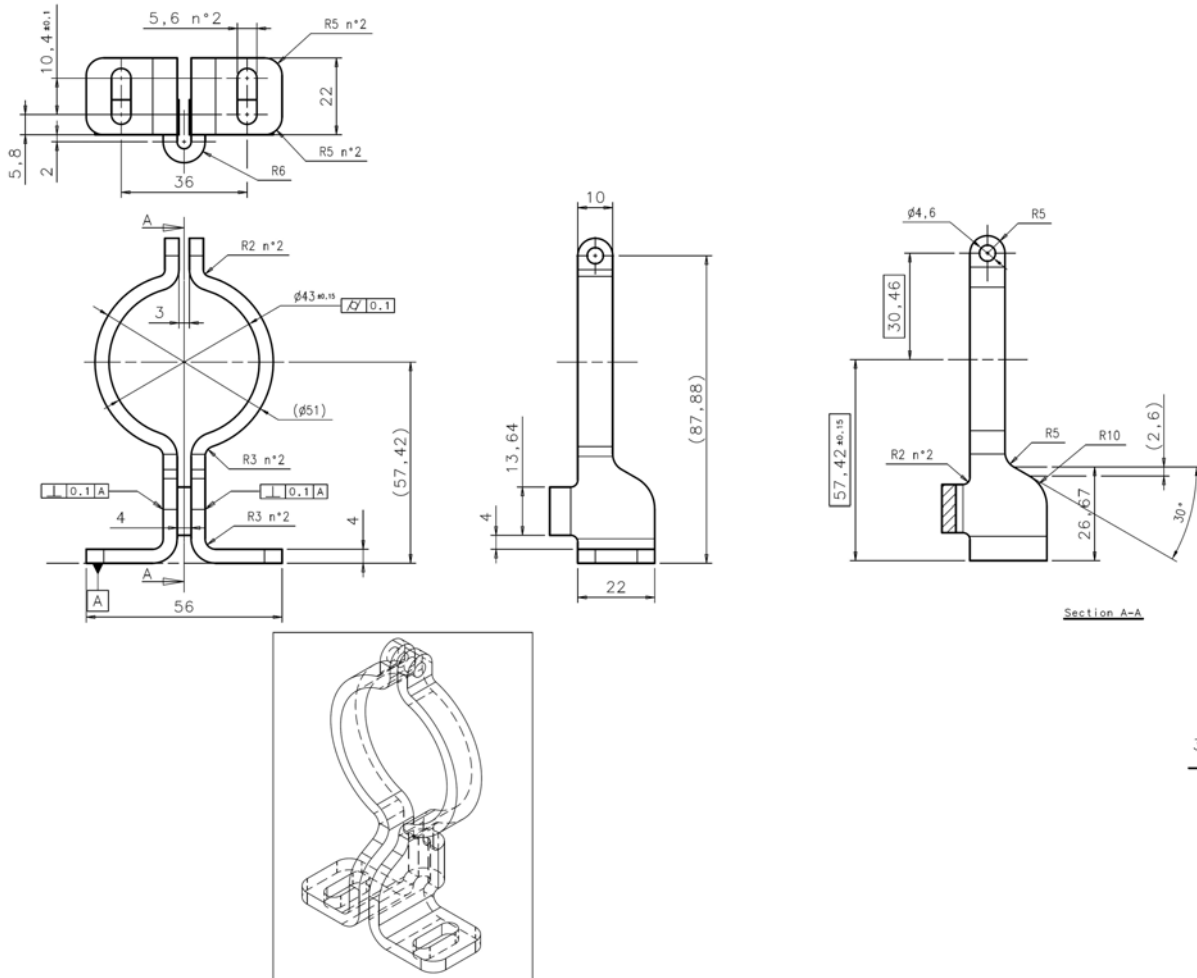

**14.2.1. Rotative fixing bracket mounting**

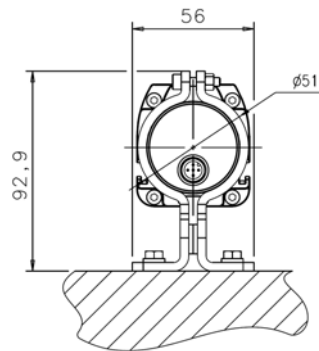

**Figure 38**

MODEL	DESCRIPTION	CODE
ST-K4ROT-SG BODY BIG	Rotative fixing bracket mounting (4 pc kit)	95ASE1960

14.3. Bottom fixing bracket

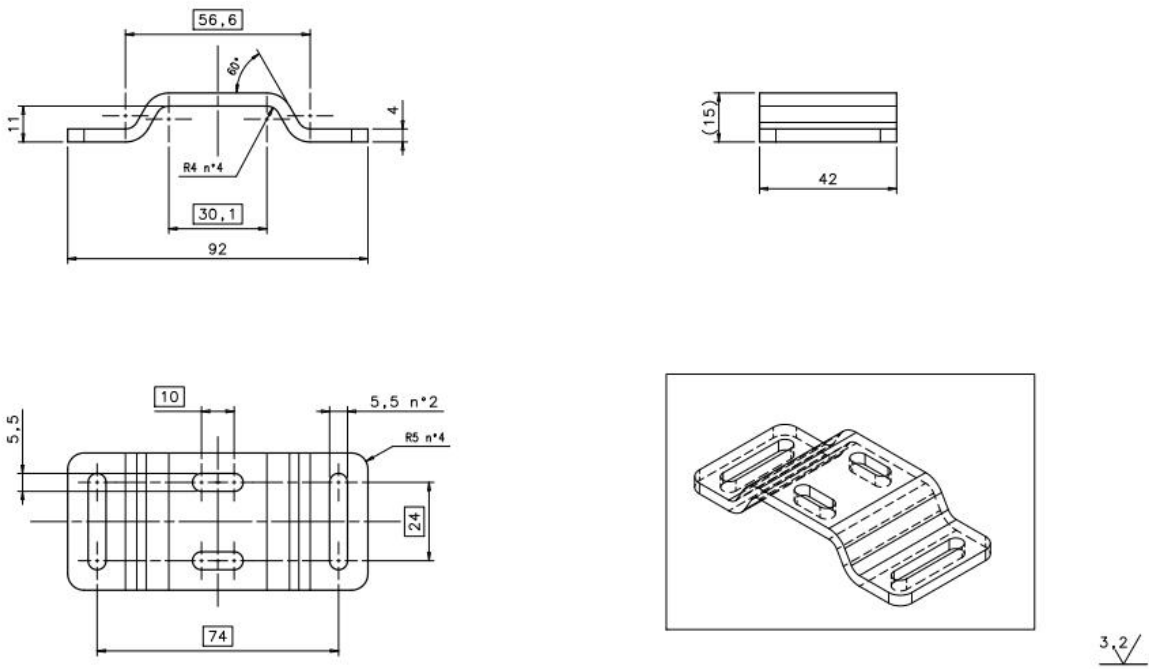

Figure 39

14.3.1. Bottom fixing bracket mounting

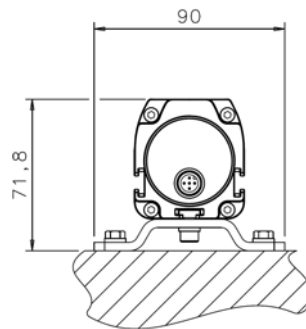

Figure 40

MODEL	DESCRIPTION	CODE
ST-K4REAR-SG BODY BIG	Bottom fixing bracket mounting (4 pc kit)	95ASE1970

14.4. Deviating mirrors

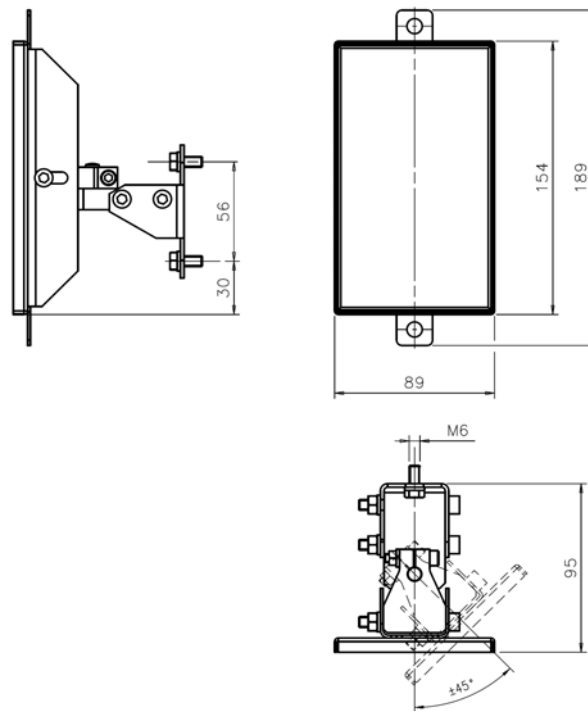

Figure 41

MODEL	DESCRIPTION	CODE
SG-DM 150	Deviating mirror version 150 mm	95ASE1670

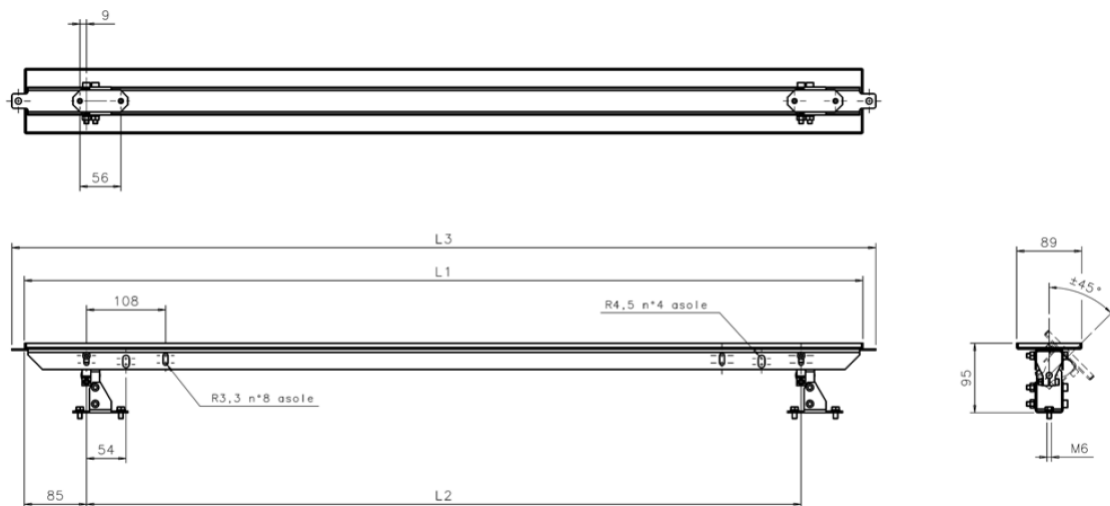
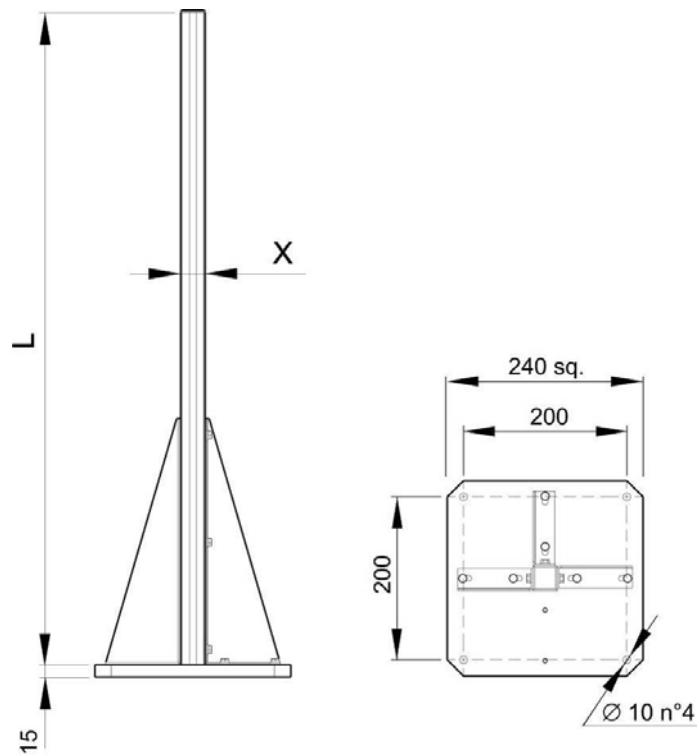

Figure 42

MODEL	DESCRIPTION	L <sub>1</sub> (mm)	L <sub>2</sub> (mm)	L <sub>3</sub> (mm)	CODE
SG-DM 600	Deviating mirror version 600 mm	545	376	580	95ASE1680
SG-DM 900	Deviating mirror version 900 mm	845	676	880	95ASE1690
SG-DM 1200	Deviating mirror version 1200 mm	1145	976	1180	95ASE1700
SG-DM 1650	Deviating mirror version 1650 mm	1595	1426	1630	95ASE1710
SG-DM 1900	Deviating mirror version 1900 mm	1845	1676	1880	95ASE1720

14.5.

14.6. Column and floor stands



MODEL	DESCRIPTION	L (mm)	X (mm)	CODE
SE-S 800	Column and floor stand H= 800 mm	800	30x30	95ACC1730
SE-S 1000	Column and floor stand H= 1000 mm	1000	30x30	95ACC1740
SE-S 1200	Column and floor stand H= 1200 mm	1200	30x30	95ACC1750
SE-S 1500	Column and floor stand H= 1500 mm	1500	45x45	95ACC1760
SE-S 1800	Column and floor stand H= 1800 mm	1800	45x45	95ACC1770

**14.7. Protective stands**

SG BODY light curtains can be housed in protective stands, composed by SG-SB and SG-PS accessories.

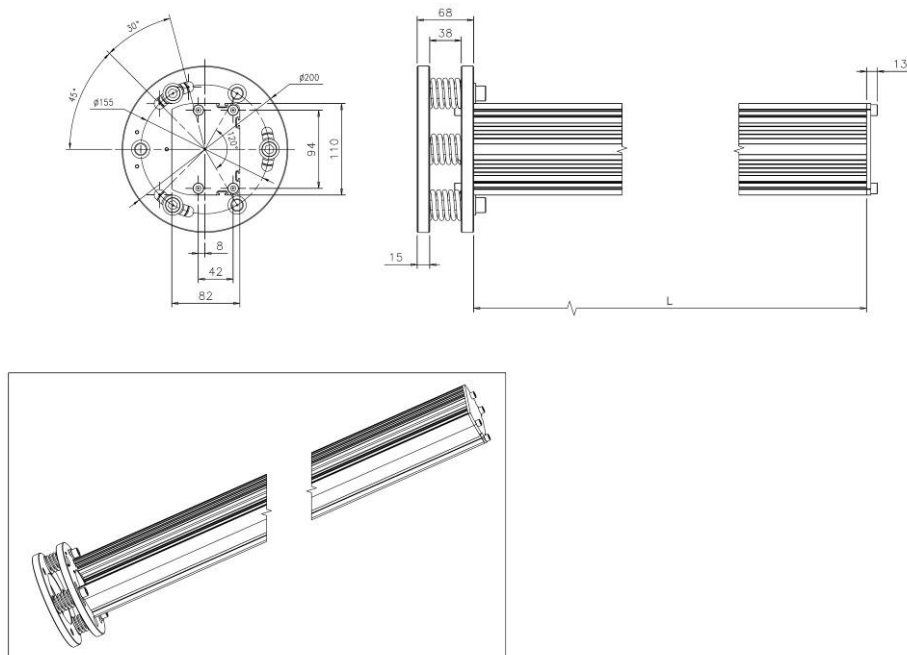

MODEL	DESCRIPTION	CODE
SG-SB	Carter	95ASE1660

MODEL	DESCRIPTION	L (mm)	CODE
SG-PS 600	Protective stand H= 600 mm	600	95ASE1610
SG-PS 900	Protective stand H= 900 mm	900	95ASE1620
SG-PS 1200	Protective stand H= 1200 mm	1200	95ASE1630
SG-PS 1650	Protective stand H = 1650 mm	1650	95ASE1640
SG-PS 1900	Protective stand H = 1900 mm	1900	95ASE1650

**14.8. Test Piece**

MODEL	DESCRIPTION	CODE
TP-40	Test piece Ø 40 mm	95ASE1820
TP-50	Test piece Ø 50 mm	95ASE1790
TP-90	Test piece Ø 90 mm	95ASE1800

14.9. Laser pointer

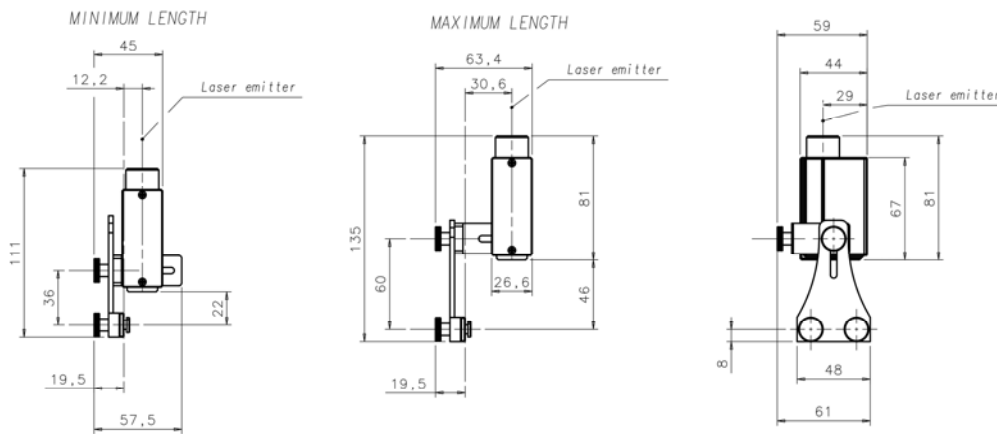

MODEL	DESCRIPTION	CODE
SG-LP	SG-LP Laser pointer	95ASE5590

14.10. Connection cables

MODEL	DESCRIPTION	CODE
CS-A1-03-U-03	5-pole M12 cable (axial) 3 m	95ASE1170
CS-A1-03-U-05	5-pole M12 cable (axial) 5 m	95ASE1180
CS-A1-03-U-10	5-pole M12 cable (axial) 10 m	95ASE1190
CS-A1-03-U-15	5-pole M12 cable (axial) 15 m	95ASE1200
CS-A1-03-U-25	5-pole M12 cable (axial) 25 m	95ASE1210
CS-A1-03-U-50	5-pole M12 cable (axial) 50m	95A252700
CS-A1-06-U-03	8-pole M12 cable (axial) 3 m	95ASE1220
CS-A1-06-U-05	8-pole M12 cable (axial) 5 m	95ASE1230
CS-A1-06-U-10	8-pole M12 cable (axial) 10 m	95ASE1240
CS-A1-06-U-15	8-pole M12 cable (axial) 15 m	95ASE1250
CS-A1-06-U-25	8-pole M12 cable (axial) 25 m	95ASE1260
CS-A1-06-U-50	8-pole M12 cable (axial) 50 m	95A252710
CS-A1-10-U-03	12-pole M12 cable (axial) 3 m	95A252720
CS-A1-10-U-05	12-pole M12 cable (axial) 5 m	95A252730
CS-A1-10-U-10	12-pole M12 cable (axial) 10 m	95A252740
CS-A1-10-U-15	12-pole M12 cable (axial) 15 m	95A252750
CS-A1-10-U-25	12-pole M12 cable (axial) 25 m	95A252760
CS-A1-10-U-50	12-pole M12 cable (axial) 50 m	95A252770

14.11. Safety relay SE-SR2

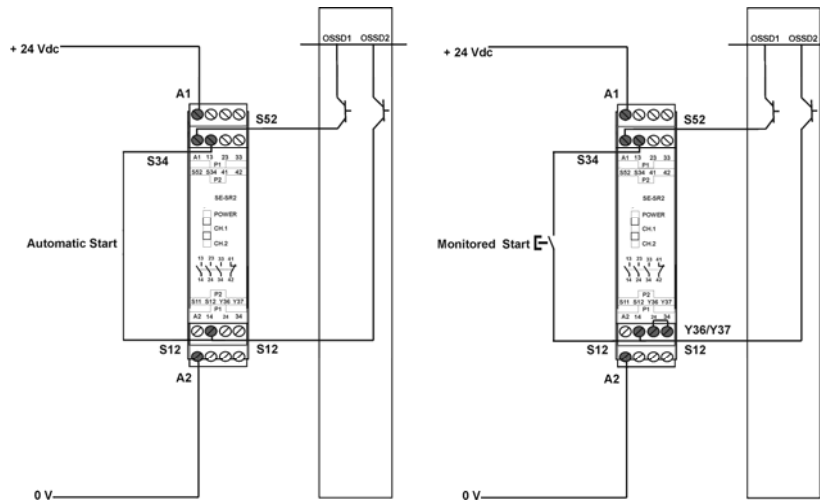

The drawing shows the connection between the safety light curtain and the Type 4 safety relay of the SE-SR2 series functioning in the automatic Start mode (left side) and manual Start with monitoring (right side).

MODEL	DESCRIPTION	CODE
SE-SR2	Type 4 safety relay - 3 NO 1NC	95ACC6170

## 15. GLOSSARY

**ACTIVE OPTOELECTRONIC PROTECTIVE DEVICE (AOPD):** its detection function is achieved thanks to the use of optoelectronic receivers and emitters detecting the optical beams interruptions inside the device caused by an opaque object present inside the specified detecting area.

An active optoelectronic protective device (AOPD) can operate both in emitter-receiver mode and in retro-reflective light curtains.

**BLOCK CONDITION (=BREAK):** status of the light curtain taking place when a suitably-sized opaque object (see DETECTING CAPACITY) interrupts one or several light curtain beams.

Under these conditions, OSSD1 and OSS2 light curtain outputs are simultaneously switched OFF within the device response time.

**BREAK:** see "Block condition" in the glossary.

**CONTROLLED MACHINE:** machine having the potentially-dangerous points protected by the light curtain or by another safety system.

**CROSSING HAZARD:** situation under which an operator crossing the area controlled by the safety device and this latter stops and keeps the machine stopped until the hazard is eliminated, and then enters the dangerous area. Now the safety device could not be able to prevent or avoid an unexpected restart of the machine with the operator still present inside the dangerous area.

**DANGEROUS AREA:** area representing an immediate or imminent physical hazard for the operator working inside it or who could get in contact with it.

**DETECTING CAPACITY:** sensor function parameter limit as specified by the manufacturer, which activates the electrosensitive protection equipment (ESPE). In case of an active optoelectronic protective device (AOPD), with resolution we mean the minimum dimension, which an opaque object must have in order to interrupt at least one of the beams that constitute the sensitive area.

**EDM:** see "External device monitoring" in the glossary.

**ELECTROSENSITIVE PROTECTIVE EQUIPMENT (ESPE):** assembly of devices and/or components working together to activate the protective disabling function or to detect the presence of something and including at least: a sensor, command/control devices and output signal switching devices.

**EMITTER:** unit emitting infrared beams, consisting of a set of optically-synchronised LEDs. The emitting unit, combined with the receiving unit (installed in the opposite position), generates an optical "curtain", *i.e.* the detecting area.

**EXTERNAL DEVICE MONITORING (EDM):** device used by the ESPE to monitor the status of the external command devices.

**FINAL SWITCHING DEVICE (FSD):** part of the control system involving machine safety conditions. It breaks the circuit to the machine primary control element (MPCE) when the output signal switching device (OSSD) becomes inactive.

**FORCE-GUIDED CONTACTS:** Contacts can be guided forcibly when they are connected mechanically so that they can switch simultaneously, when the input stage is active.

If one contact of the series remains "hanged", no other relay contact is able to move.

This function allows the control of the EDM status.

**MACHINE OPERATOR:** qualified person allowed to use the machine.

**MACHINE PRIMARY CONTROL ELEMENT (MPCE):** electrically-powered element having the direct control of machine regular operation so as to be the last element, in order of time, to operate when the machine has to be enabled or blocked.



**MIN. INSTALLATION DISTANCE:** min. distance necessary to allow machine dangerous moving parts to completely stop before the operator can reach the nearest dangerous point. This distance shall be measured from the middle point of the detecting area to the nearest dangerous point. Factors affecting min. installation distance value are machine stop time, total safety system response time and light curtain resolution.

**N.O.:** normally opened

**N.C.:** normally closed

**OFF STATUS:** status when the output circuit is interrupted and does not allow current stream.

**ON STATUS:** status when the output circuit is operational and allows current stream.

**OUTPUT SIGNAL SWITCHING DEVICE (OSSD):** part of the ESPE connected to machine control system. When the sensor is enabled during standard operating conditions, it switches to disabled status.

**PROTECTED AREA:** area where a specified test object is detected by the ESPE.

**PROTECTIVE DEVICE:** device having the function to protect the operator against possible risks of injury due to the contact with machine potentially-dangerous parts.

**QUALIFIED OPERATOR:** a person who holds a professional training certificate or having a wide knowledge and experience and who is acknowledged as qualified to install and/or use the product and to carry out periodical test procedures.

**RECEIVER:** unit receiving infrared beams, consisting of a set of optically-synchronised phototransistors. The receiving unit, combined with the emitting unit (installed in the opposite position), generates an optical "curtain", i.e. the detecting area.

**RESOLUTION:** see "Detecting capacity" in the glossary.

**RESPONSE TIME:** max. time elapsing between the occurrence of the event leading to sensor activation and the reaching of the inactive state by the output signal switching device (OSSD).

**RESTART:** see "Restart Interlocking Device" in the glossary.

**RESTART INTERLOCKING DEVICE:** device preventing machine automatic restart after sensor activation during a dangerous phase of machine operating cycle, after a change of machine operating mode, and after a variation in machine start control devices.

**RISK:** probability of occurrence of an injury and severity of the injury itself.

**SAFETY LIGHT CURTAIN:** it is an active optoelectronic protective device (AOPD) including an integrated system consisting of one or several emitting elements and one or several receiving elements forming a detection area with a detecting capacity specified by the supplier.

**START INTERLOCKING DEVICE (= START):** device preventing machine automatic start if the ESPE is live or the voltage is disabled and enabled once again.

**TEST PIECE:** opaque object having a suitable size and used to test safety light curtain correct operation.

**TYPE (OF ESPE):** the Electrosensitive Protective Equipment (ESPE) have different reactions in case of faults or under different environmental conditions. The classification and definition of the "type" (ex. type 2, type 4, according to IEC 61496-1) defines the minimum requirements needed for ESPE design, manufacturing and testing.

**WORKING POINT:** machine position where the material or semifinished product is worked.

