

**GUIDA PER L'INSTALLAZIONE RAPIDA**  
**QUICK INSTALLATION GUIDE**

# EOX 30W

**Headquarters**

Via Lavino, 265  
40050 Monte San Pietro  
Bologna - Italy  
Tel. +39 051 6765611  
Fax +39 051 6759324  
Purchasing Dept. Fax +39 051 6765499  
info.automation.it@datalogic.com

**Laser Marking operation offices****Donnas**

Reg. Gurey, via Le Gorrey, 10  
11020 Donnas (AO) - ITALY  
Tel. +39 0125 8128201  
Fax +39 0125 8128401

**Sesto Calende**

Via dell'Industria, 20  
21018 Sesto Calende (VA) - ITALY  
Tel. +39 0331 9180601  
Fax +39 0331 9180801

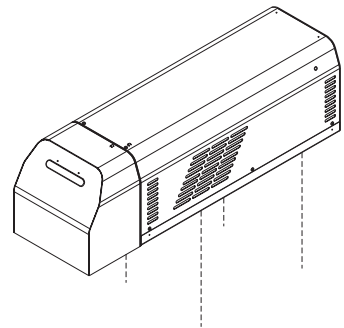

1. Fissare risonatore.  
1. Fixing resonator.

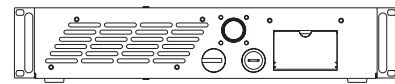

2. Fissare Rack di controllo.  
2. Secure control rack.

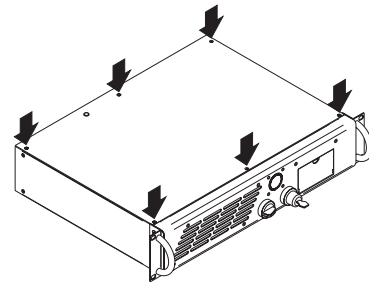

3. Rimuovere la cover.  
3. Remove rack cover.

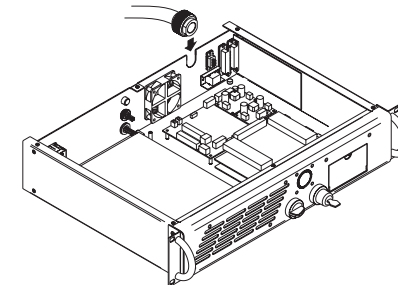

4. Agganciare il passacavo al rack.  
4. Hook the main cable.

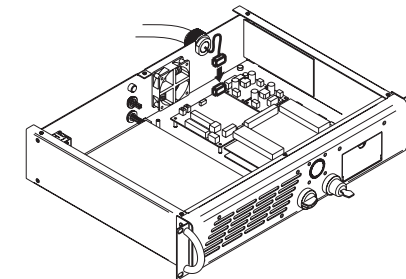

5. Collegare cavo rack-risonatore (J7).  
5. Connect rack-resonator cable (J7).

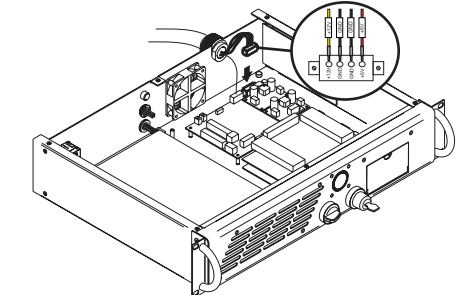

6. Cablare morsetti di alimentazione (J18).  
6. Wire power supply terminal blocks (J18).

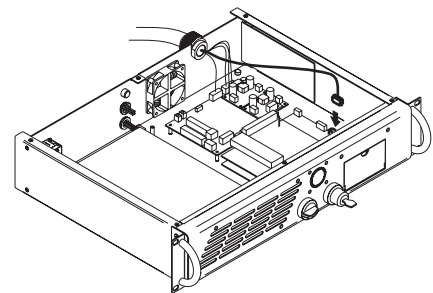

7. Connettere cavo iMark (J2001).  
7. Plug iMark connector (J2001).

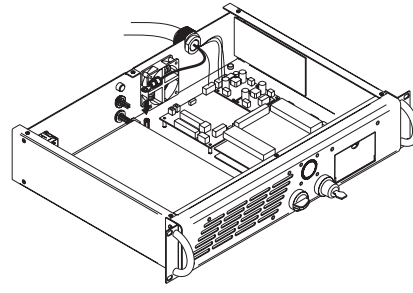

8. Collegare cavo di terra.  
8. Wire earth cable.

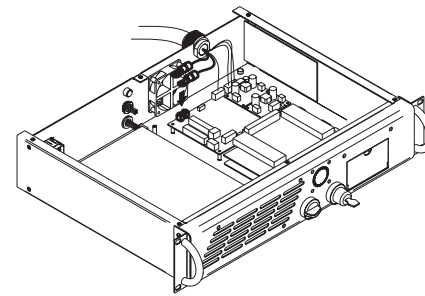

9. Collegare l'alimentazione 30Vdc.  
9. Plug 30Vdc power supply.

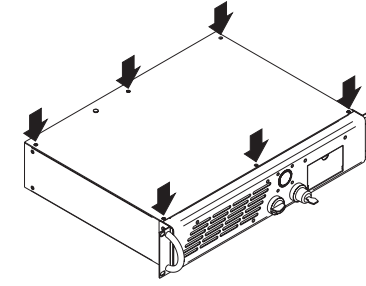

10. Chiudere la cover.  
10. Close rack cover.

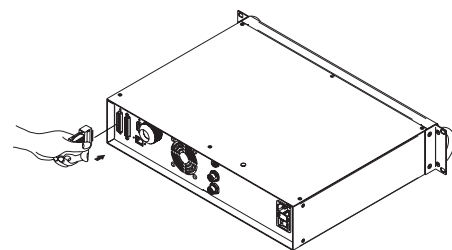

11. Collegare la Command Box.  
11. Wire the Command Box.

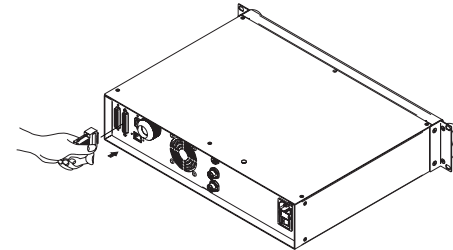

12. Collegare gli assi.  
12. Wire the axes.

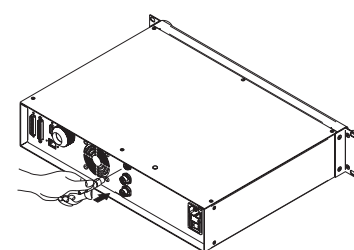

13. Collegare il connettore di Interlock.  
13. Wire the Interlock connector.

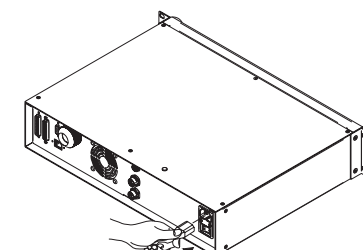

14. Collegare il cavo di alimentazione.  
14. Wire power supply cable.

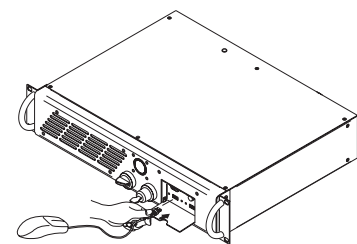

15. Collegare il mouse.  
15. Plug the mouse.

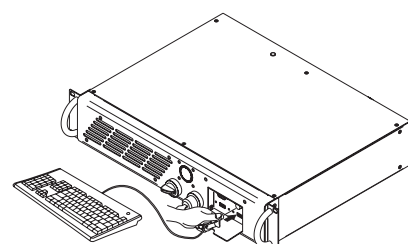

16. Collegare la tastiera.  
16. Plug the keyboard.

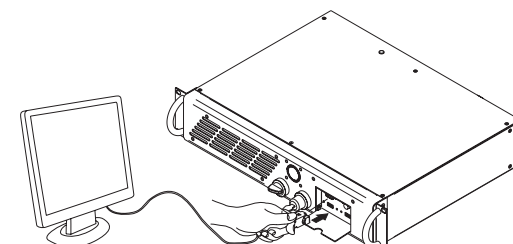

17. Collegare il monitor.  
17. Plug the monitor.

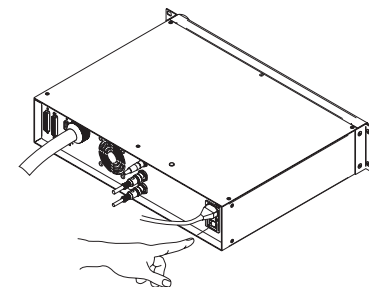

18. Accendere il dispositivo.  
18. Power ON the device.

### ESEMPIO DI CONNESSIONE. CONNECTION EXAMPLE.

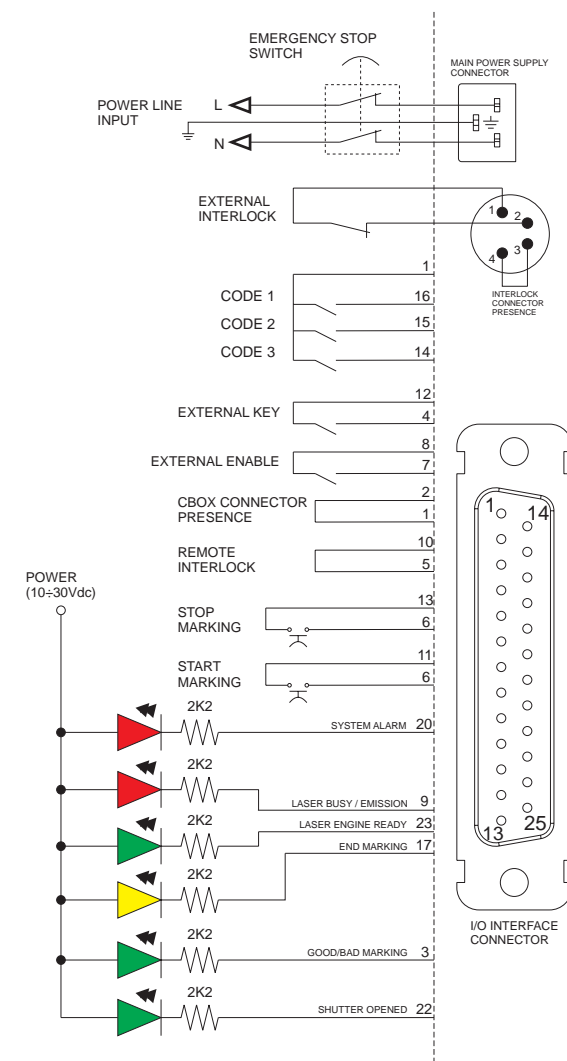

**NOTA:**  
Per una corretta installazione del dispositivo Eox, consultare il Manuale d'Uso  
**NOTE:**  
For a right installation of Eox devices, please consult User's Manual



**ATTENZIONE:**  
Il dispositivo Eox è un laser di classe 4. Per il corretto utilizzo in sicurezza deve essere portato a classe 1.  
**ATTENTION:**  
The Eox device is a class 4 laser. For proper use in full safety, it must be modified to class 1.